

MEC 800 SPECIAL

- FITTING INSTRUCTIONS
- FOR DOUBLE SWINGING GATES

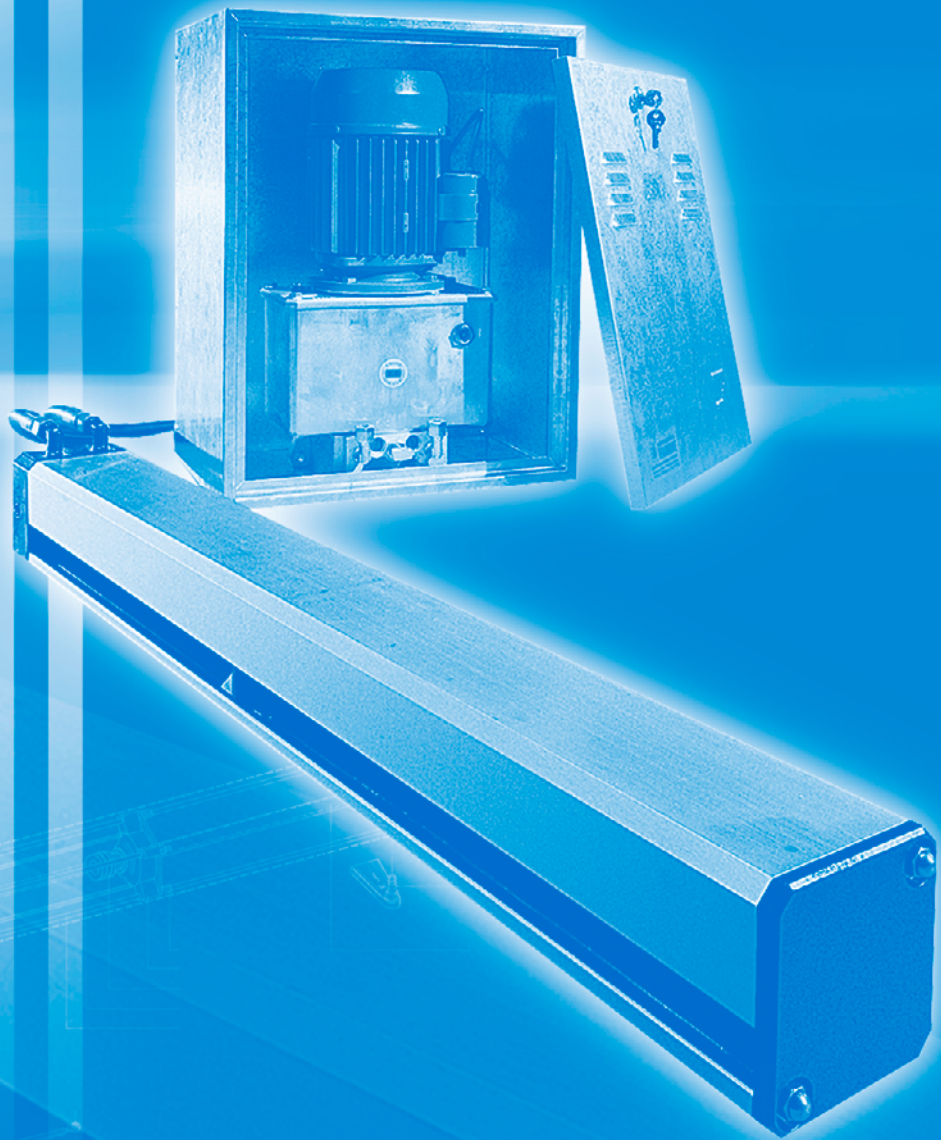

INSTALLATION MANUAL

GB

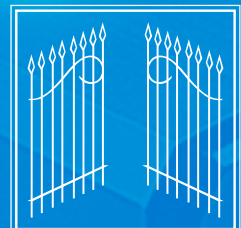

FADINI[®]
the gate opener

MEC 800 SPECIAL

OIL-HYDRAULIC OPERATOR FOR SWINGING GATES. EXTERNAL APPLICATION.

ESSENTIAL COMPONENTS TO FIT THE OPERATOR TO A GATE LEAF

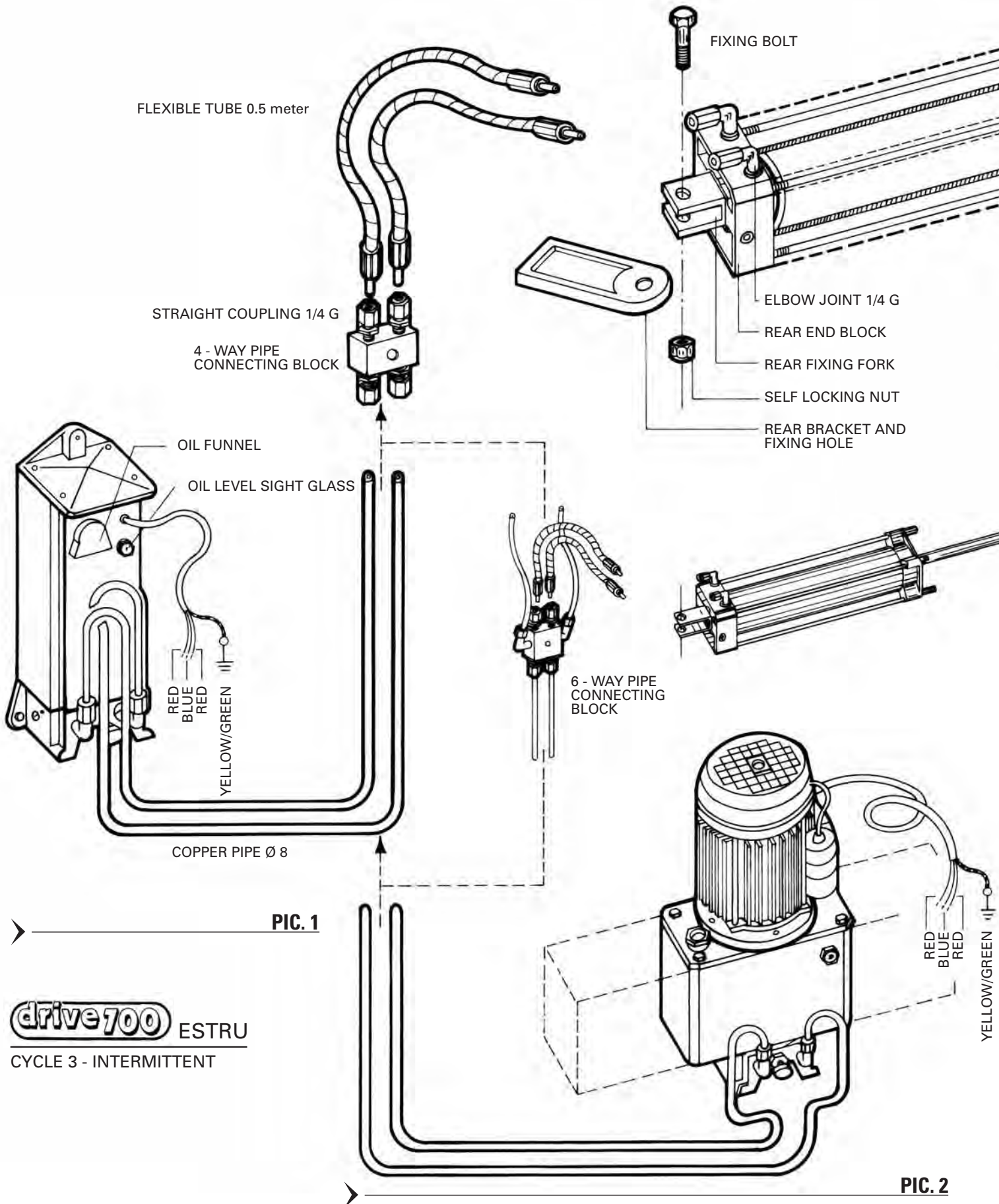

drive700 ESTRU
CYCLE 3 - INTERMITTENT

PISTON 1

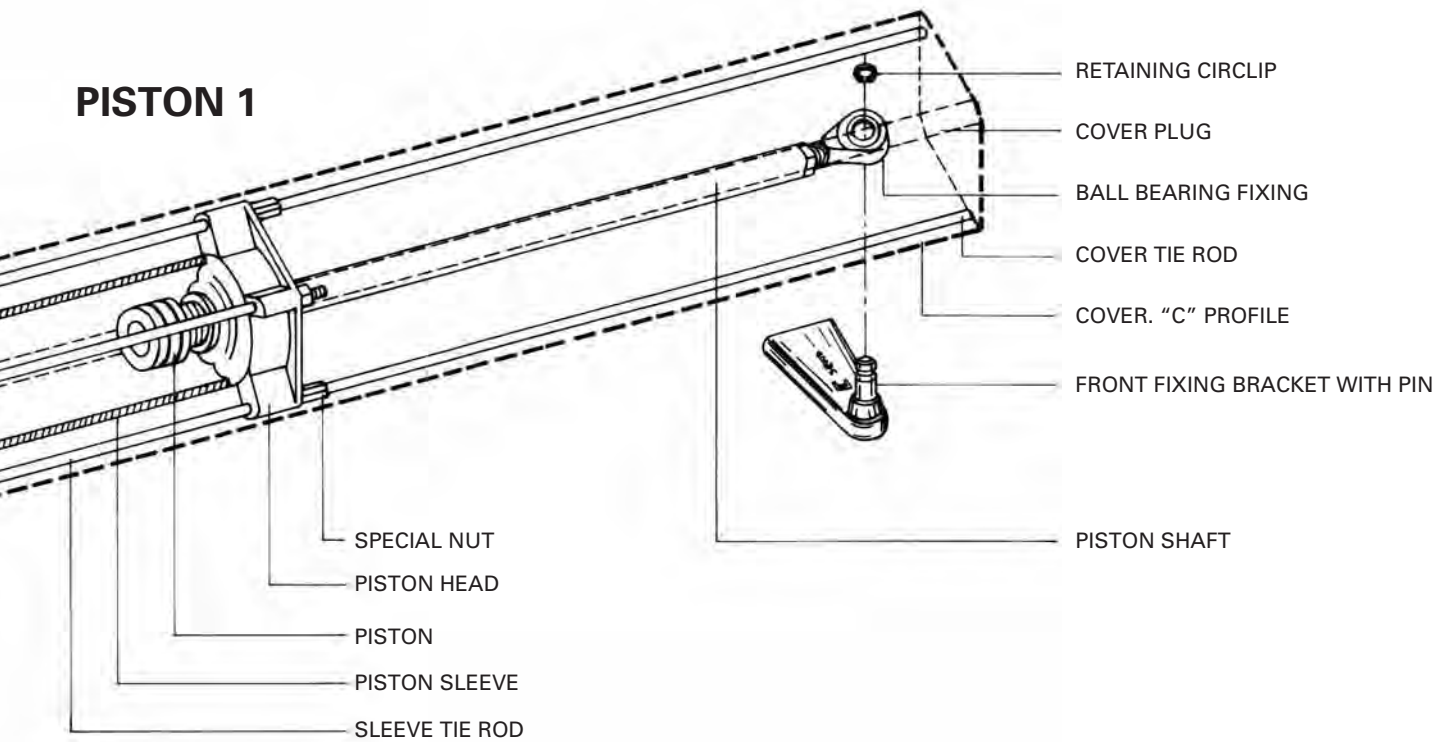

PIC. 3 - Oil-Hydraulic actuator. Assembly drawing

PISTON 2



Drive 700 Estru (Pic. 1) is an electro-hydraulic motor pump unit fitted with bi-directional gate locking device, suitable for single applications when the gate involved is not particularly large and only one actuator Mec 800 Special is required. Being quite compact, this unit can be installed either close to the gate post or recessed in a brick pier by means of a galvanized enclosure which can be supplied on request. Very precise component parts and the special oil which is used in the hydraulic circuit make it extremely reliable. It is made up of a valve block, oil reservoir, top cover and a lockable door which gives access to the electric cable and all the electrical connections. A sight glass indicates oil level and a funnel is incorporated for filling. Adjustable pressure valves can be set to the right amount of force required to safely operate a gate open and close, while a release valve can override the locking device and allows manual operation of the system in an emergency situation or power failure. Drive 700 Estru can work to its utmost provided that is respected the recommended duty cycle, that is "S3" intermittent service.

Mec 700/80 Ventil (Pic. 2) is a very strong motor pump unit. As the above described unit it is fitted with bi-directional gate locking device, but the motor is air cooled and the oil reservoir has a greater capacity. The adjustable pressure valves and the release valve are easy to reach for setting operations. The special oil ensures proper functioning within a considerably wide range of temperature from -20°C to $+80^{\circ}\text{C}$. An enclosure is available on request to protect the unit from weather conditions or accidents. The enclosure is designed to provide enough ventilation and is fitted with a lockable door for security reasons. It can be fixed close to the gate post or recessed where a brick pier exists. The great advantage of this unit is the possibility of extra oil reservoir to operate two actuators Mec 800 Special per gate, with very large and heavy gates. Designed for heavy duty applications, S3 duty cycle, motor direction easy to reverse.

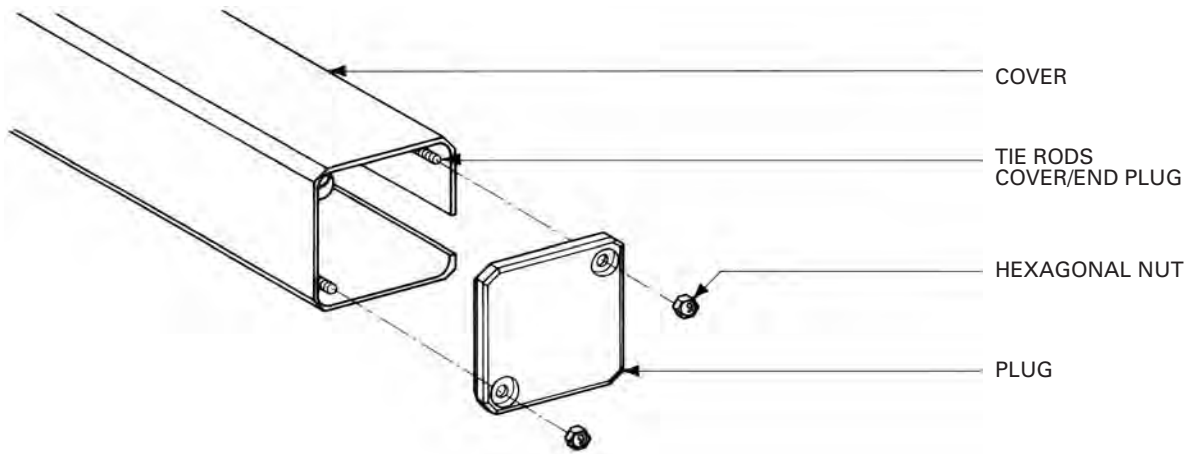

PIC. 4

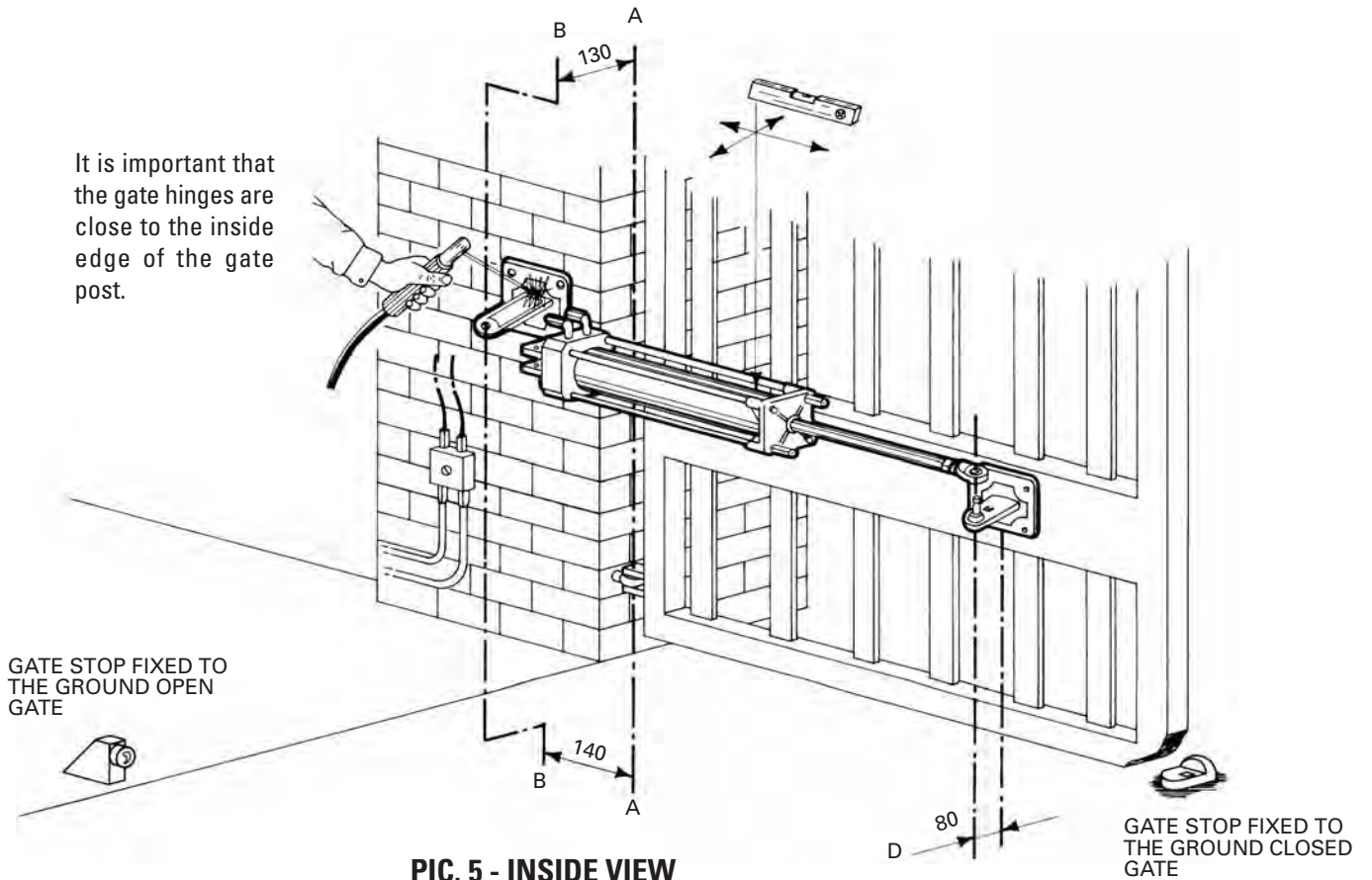

PIC. 5 - INSIDE VIEW

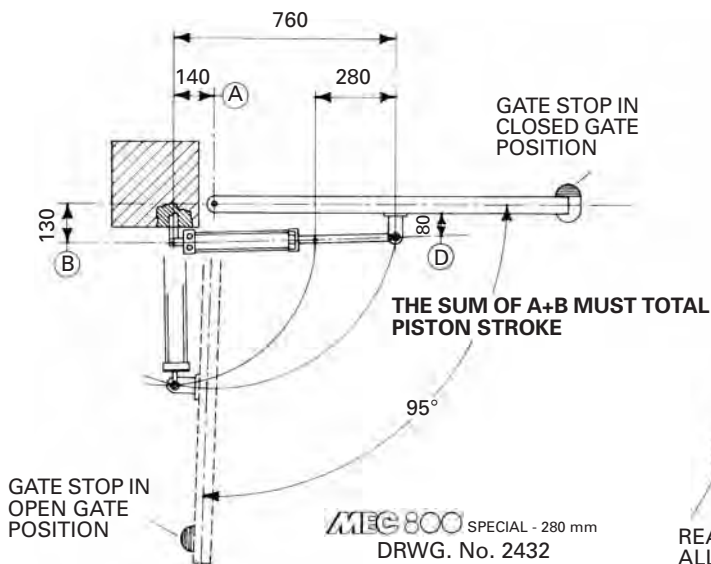

PIC. 6

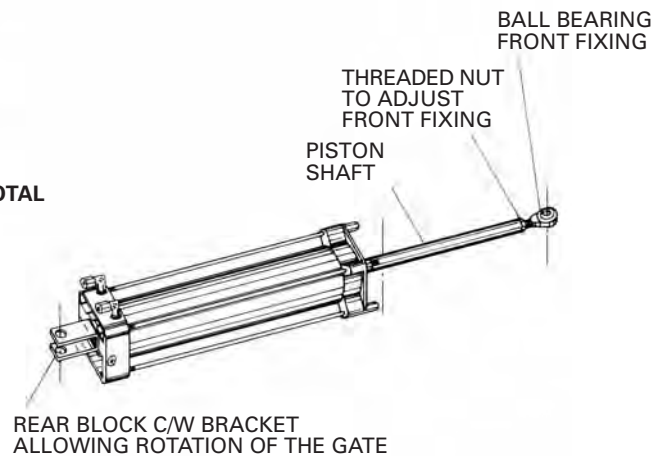

PIC. 7

Instructions to follow to fit MEC 800 to a double swinging gate. It is recommended to respect all the steps described in this manual to achieve a perfectly working installation of the system.

Before installing MEC 800 special it is important to check the structure of the gate and make sure that it is adequate to take the actuator, there must be no problems at all with the gate frame, which must be strong and robust to be electrically operated. It is recommended to strengthen and fix all the parts that look weak, or worn out, eliminate any friction of the gate against the gate post or pavement (check the hinges, the gate must be very smooth).

The actuator is mounted to the gate by specially designed plates, one to the gate and one to the gate post (Pic. 5). MEC 800 is very strong and powerful. The thrust power that it can develop is high and safe. The motor pump unit is fitted with adjustable pressure valves. It is entirely made of steel and pressure cast aluminium, the temperature range it can safely bear is -20°C $+80^{\circ}\text{C}$ (Pic. 7).

Installation: remove the anodized aluminium cover by unscrewing the two hexagonal nuts in the front cover plug (see pic. 4). Pull the cover horizontally and lay bare the cylinder, piston shaft and ball bearing front fixing. The fitting of the rear fixing plate to the gate post or brick pier can be either by welding, with the use of a square plate as in the picture, or by embedding. Anchor plates are to be used to secure the actuator plate into the concrete setting. Fixing geometry, ie. distances between hinge centre line of the gate and back fixing centre line of the actuator, are provided in pictures 5 and 6, on page 4, and pictures 21 to 23 on page 9. These are for long stroke braking actuators. Follow which applies.

Make sure that the distances A and B are $A = 140\text{ mm}$ and $B = 130\text{ mm}$ respectively measured from the gate hinge centre line to back fixing centre line. This ensures smooth and even movements of the gate. Distance D is 80 mm from the centre line of the hole in the front fixing ball to the centre line of the gate plate (pic. 6). (Distances to be referred to only with MEC 800 actuators, 280 mm stroke).

Before the square reinforcement plate is finally fixed to the gate, make some tests, the ball bearing head fully screwed in, allowing the piston to reach the very limit of the permitted stroke. Operate the gate manually to open and close. Try a second time with aluminium protection cover fitted. Once satisfied that the fixing distances are all right, remove the cover and weld the plate fully as shown in pictures 5 and 8.

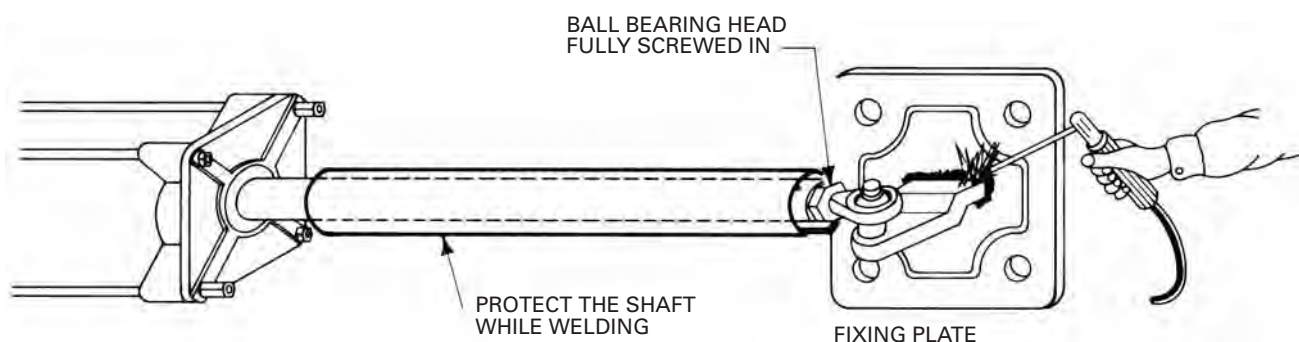

PIC. 8

Fix the front fixing plates and swing the actuator on to it, the piston shaft must be all out and the thread of ball bearing head all in, ie. not visible on the outside. The gate fully closed against its ground stop. A spirit level will tell if the actuator is perfectly straight (Pic. 5 - 8).

After completing the fixing operations of the plates, unscrew the ball bearing head 5 or 6 mm approximately and tighten the nut to lock it in the correct position. This ensures the correct position of the gate on the closed gate stop (Pic. 9)

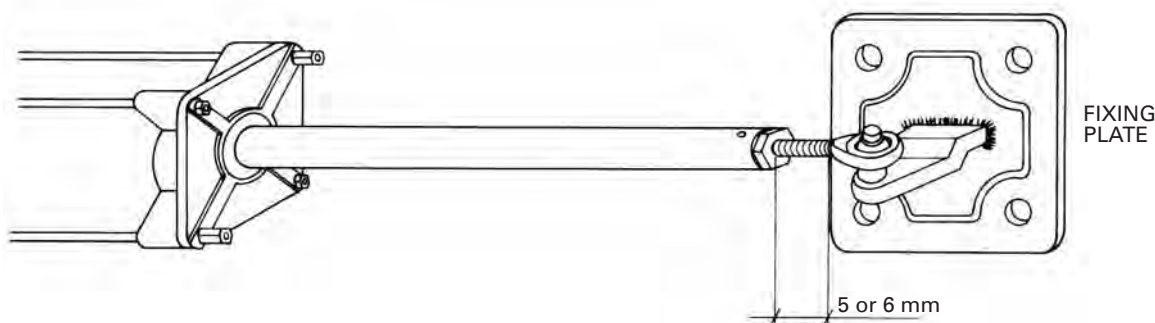

PIC. 9

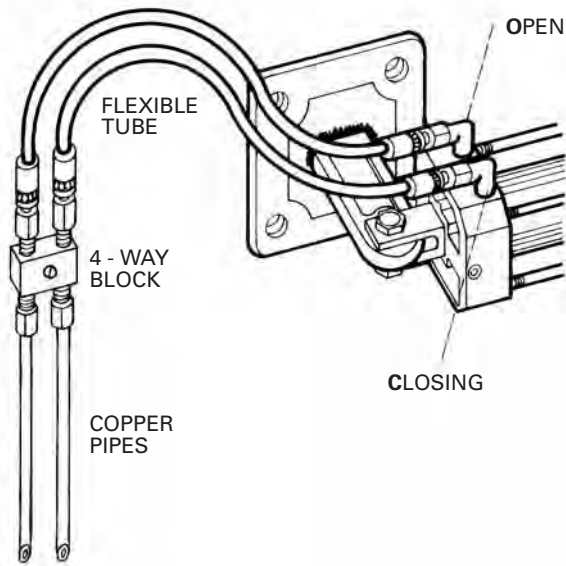

PIC. 10

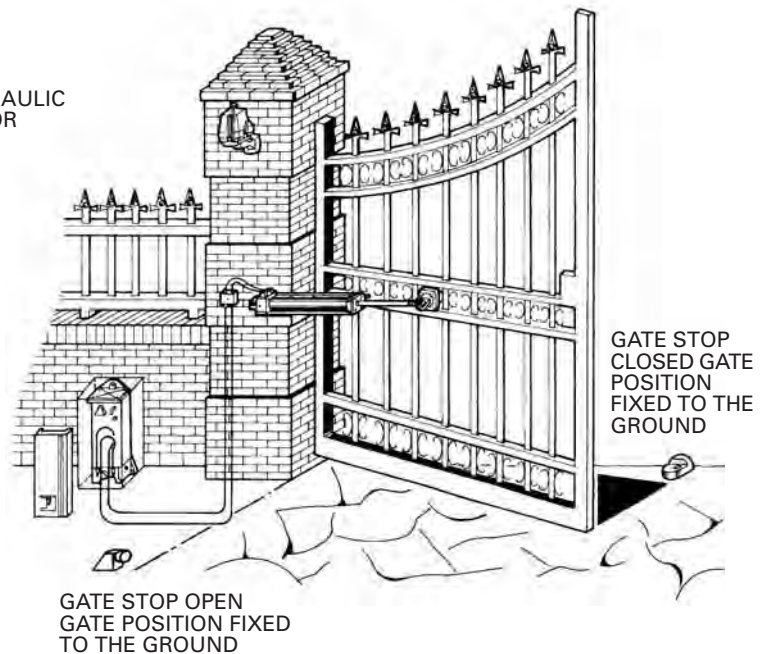

PIC. 11

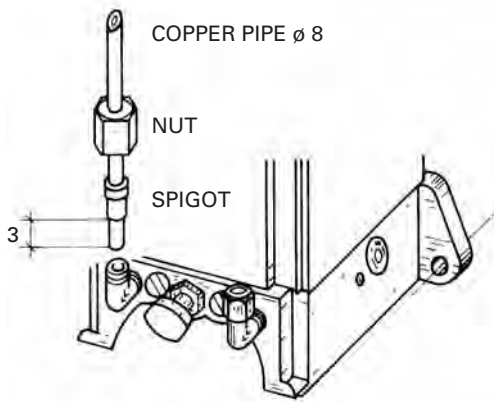

PIC. 12

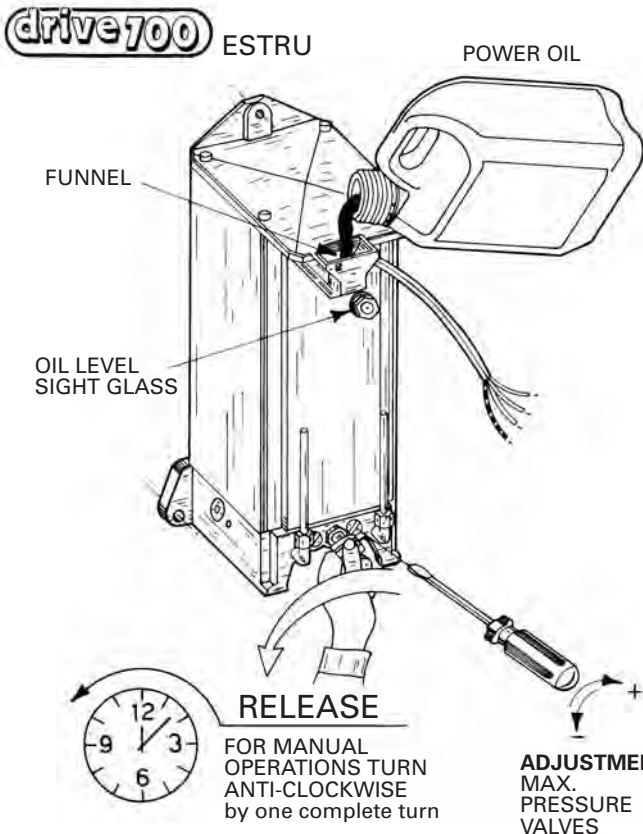

PIC. 13

Pipe layout. Before proceeding to the final fixing, lay the motor pump unit and the accessories (copper pipes, hoses, 4-way block etc.) in the most suitable position to avoid any sharp bending of the copper pipes that connect the motor pump unit to the 4-way block (Pic. 11). The flexible tubes are to be used to connect the pipe block to the actuator (Pic. 10). Keep a suitable distance to avoid rigidity of the hoses when the gates are opening. Do some manual test to prevent this from happening. Once satisfied that all distances are all right, insert the spigots, connect the pipes and hoses and carefully tighten the nuts (Pic. 12). The above instructions apply only in cases where one actuator only is fitted to each gate leaf, along with one motor pump unit type Drive 700 Estru, depending on the gate weight, not suitable for very heavy duty applications (Pic. 11).

The motor pump is not pre-oiled for transport reasons. Oil is to be filled on the installation site through the funnel incorporated under the top cover of the unit; pull the funnel 2 cm outwards and rotate the cup upwards. Fill with oil up to the level of the sight glass (Pic. 13)

In events like power failure it is necessary to override the hydraulic circuit for manual operation. Turn anti-clockwise the release knob that is fitted between the two pressure valves (Pic. 13)

It is possible to adjust the amount of force required to open and close the gates by setting the two safety pressure valves with a screwdriver as shown in Pic. 13.

TYPE OF POWER OIL: FADINI A 15 By AGIP

PLEASE NOTE: Valve A for open pressure must be driven 2 turns deeper than C close to get higher force and prevent the actuator from stopping during open cycle.

Very big and heavy gates can be fitted with two actuators type MEC 800 Special, which can meet high rating requirements very well. Fixing dimensions are the same as those quoted for one actuator, that is $A + B =$ piston stroke; see Pic. 5-6 and 21 to 23. For double mounting see Pic. 14-16.

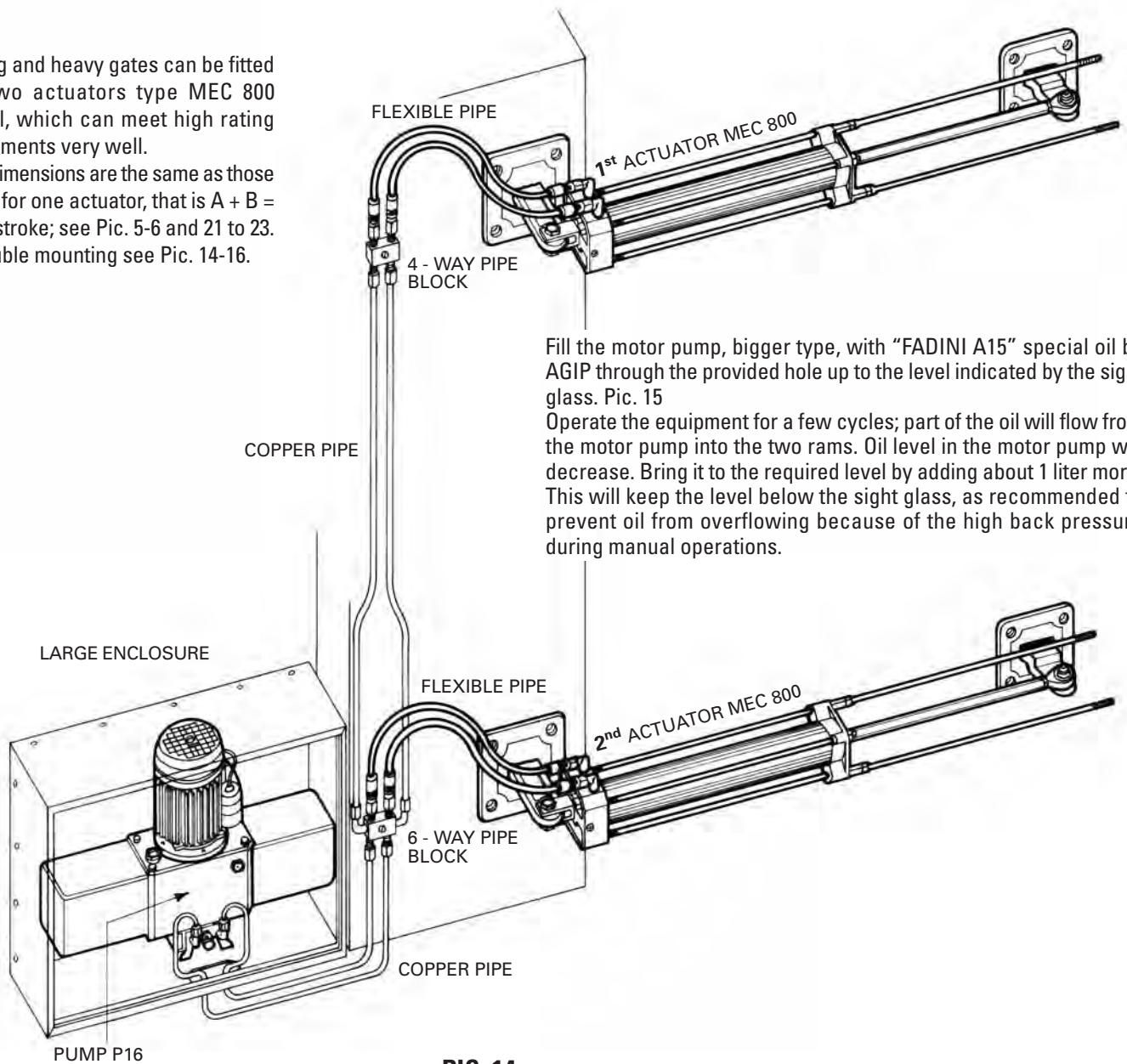

Fill the motor pump, bigger type, with "FADINI A15" special oil by AGIP through the provided hole up to the level indicated by the sight glass. Pic. 15
Operate the equipment for a few cycles; part of the oil will flow from the motor pump into the two rams. Oil level in the motor pump will decrease. Bring it to the required level by adding about 1 liter more. This will keep the level below the sight glass, as recommended to prevent oil from overflowing because of the high back pressure during manual operations.

PIC. 14

MEC 700/80 VENTIL
WITH SUPPLEMENTARY OIL CONTAINERS

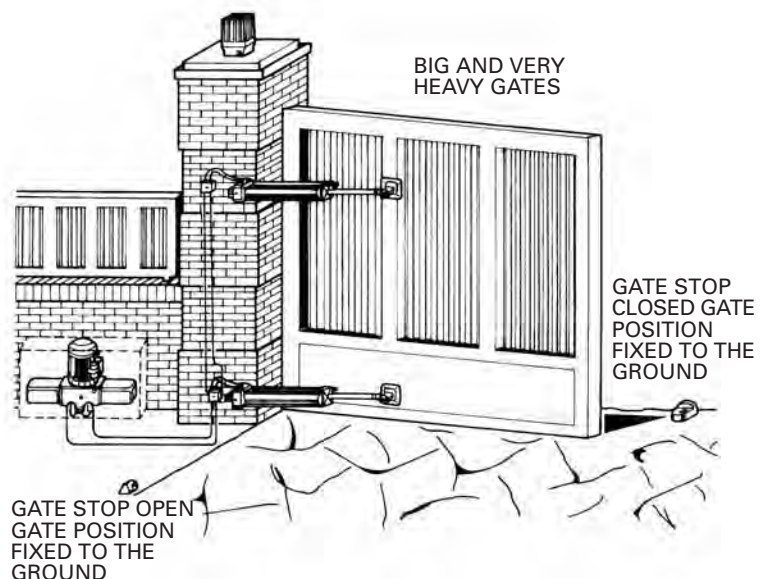
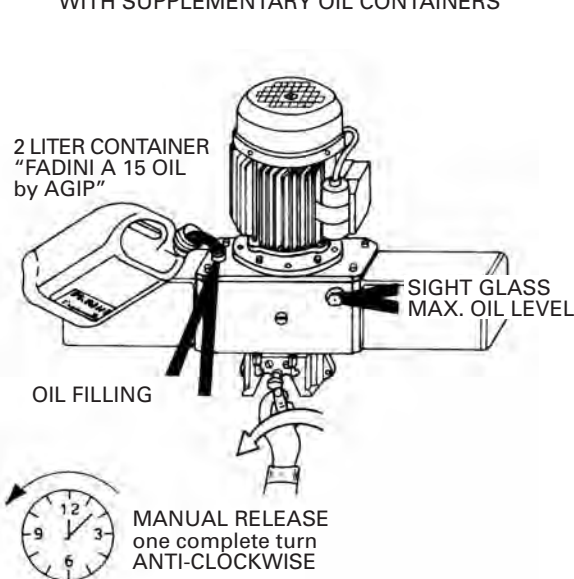

- Internal view:
special application with two actuators MEC 800

PIC. 15

PIC. 16

FITTING THE ELECTRIC LOCK

- HORIZONTAL
- VERTICAL

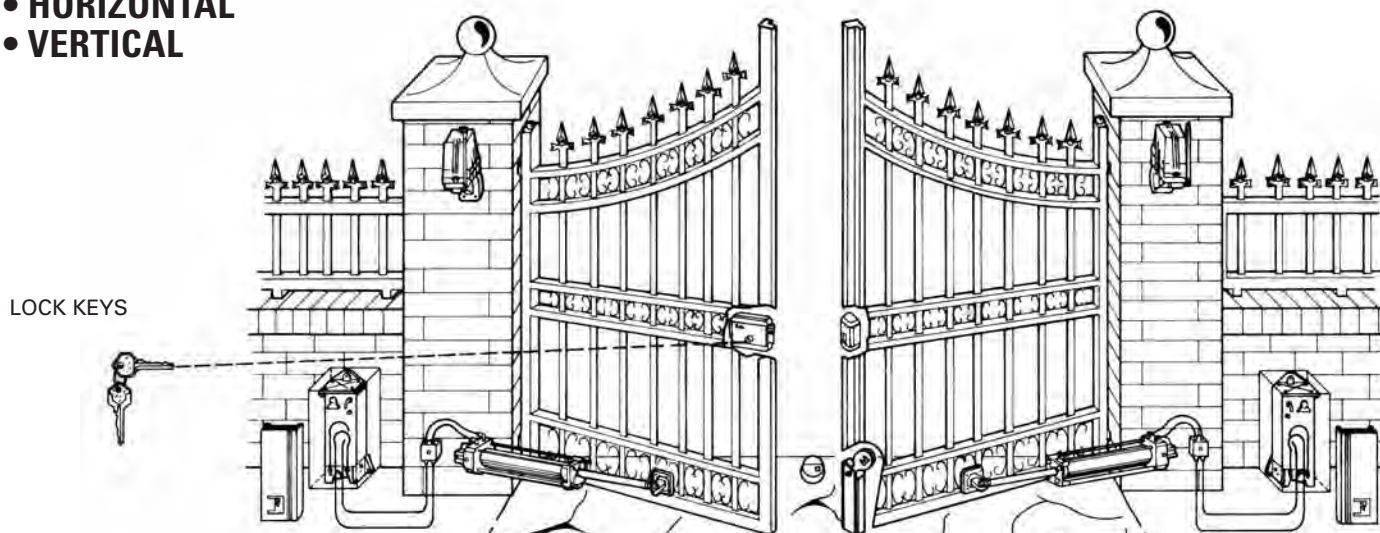

PIC. 17

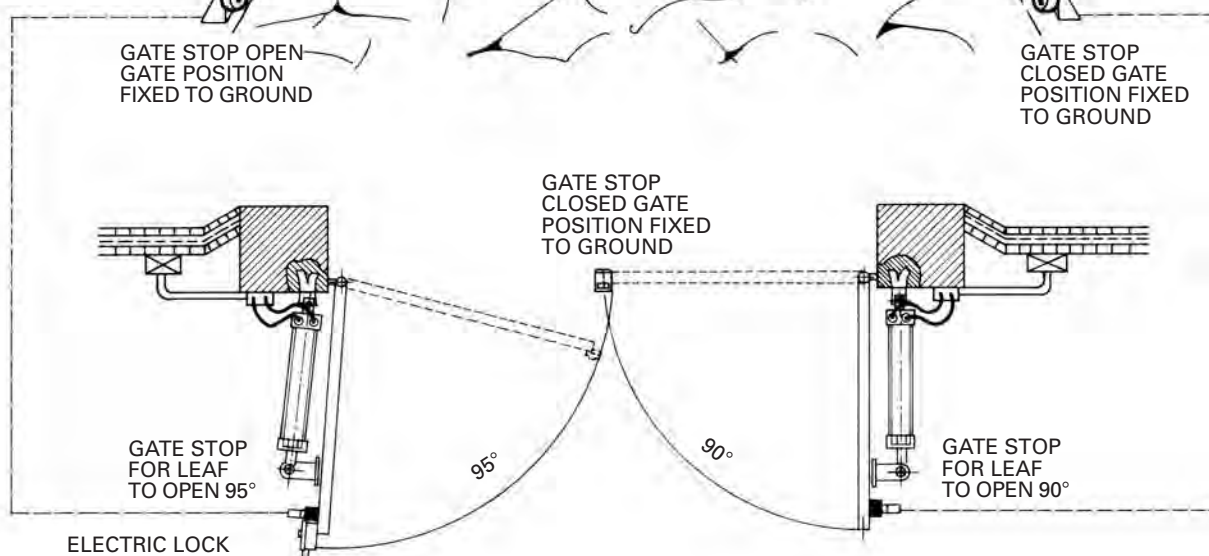

PIC. 18

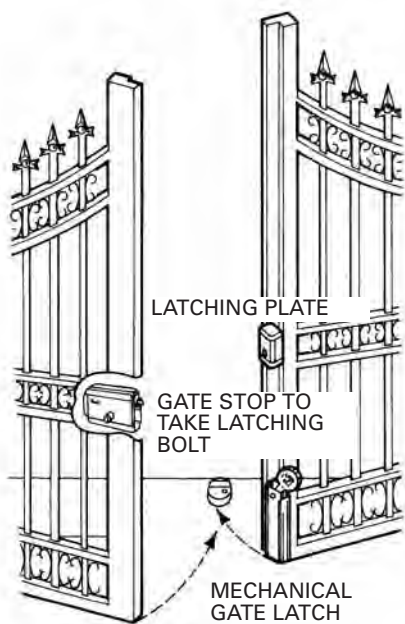

HORIZONTAL ELECTRIC LOCK

PIC. 19

WITH MEC 800 SPECIAL MOUNTED WITH THE NON LOCKING TYPE MOTOR PUMP AN ELECTRIC LOCK IS REQUIRED

One leaf gates. The electric lock is fitted to the gate horizontally; the catching plate is to be fixed to the brick pier or post. Two leaf gates. With double swinging gates, the electric lock can be fitted either horizontally or vertically. If mounted horizontally refer to pictures 17 and 19; please note the gate stop on the closed gate position. It has a special design to stop the gates and take the bolt of the mechanical latching device to secure the gates in the closed position. If mounted vertically, picture 20 refers. The gate stop to take the gates and the bolt of the lock. The gate leaf that is fitted with the electric lock must be operated with a 5 degree angle displacement to ensure that both leaves can complete their respective travels independently and prevent jamming on reaching the closed gate stop. It is very important that each gate leaf is fitted with gate stops in the fully open positions at the end of the permitted piston stroke. Pic. 18

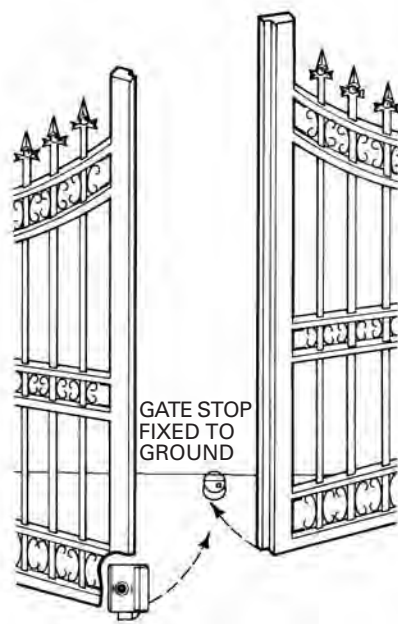

VERTICAL ELECTRIC LOCK

PIC. 20

OTHER FIXING DISTANCES TO SUIT TYPE OF ACTUATOR PROVIDED

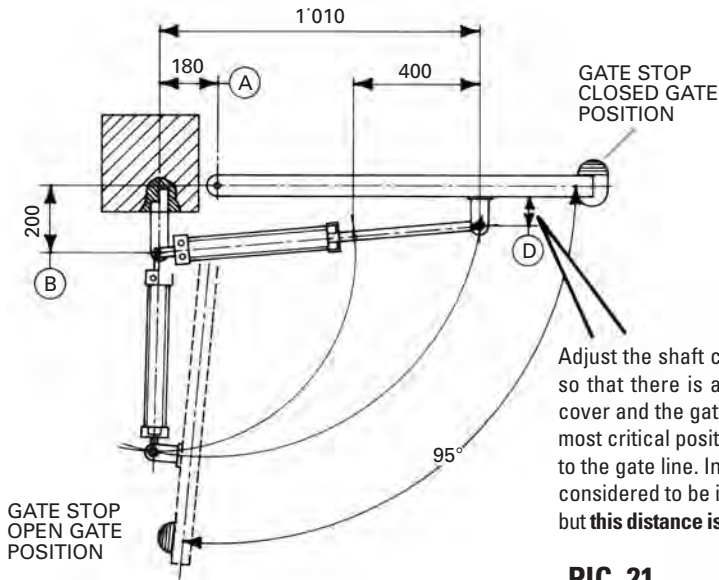

Adjust the shaft connection to a suitable distance so that there is a **10 mm clearance** between the cover and the gate when the operator line is in the most critical position, ie. About 60 degrees inclined to the gate line. In most cases this distance can be considered to be included between 90 and 100 mm, but **this distance is not applicable to all installations.**

PIC. 21

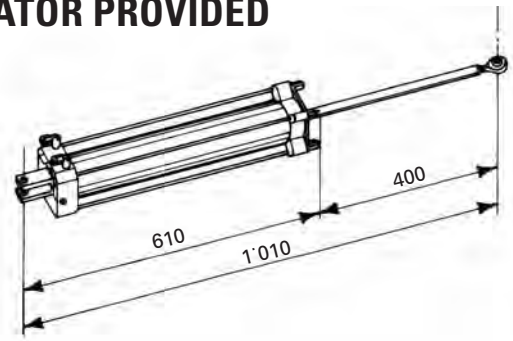

MEC 800 SPECIAL
400 mm
DRWG. No. 2433

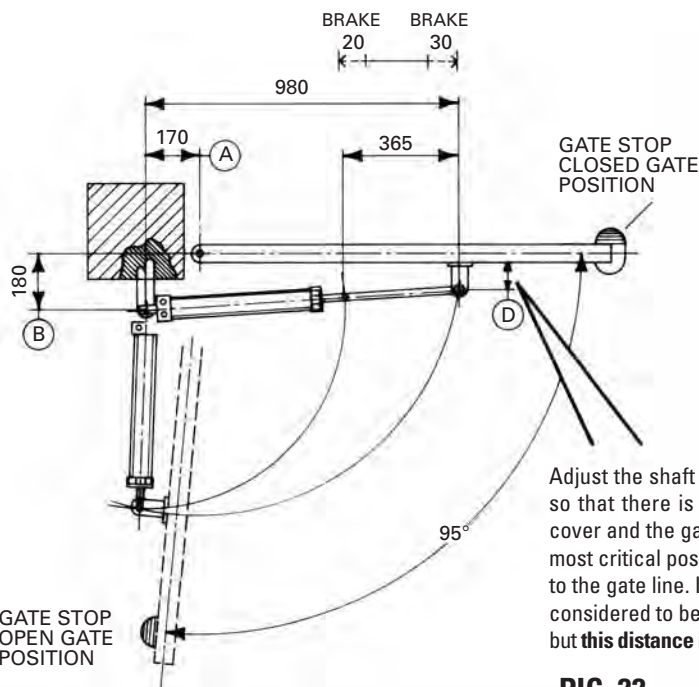

Adjust the shaft connection to a suitable distance so that there is a **10 mm clearance** between the cover and the gate when the operator line is in the most critical position, ie. About 60 degrees inclined to the gate line. In most cases this distance can be considered to be included between 90 and 100 mm, but **this distance is not applicable to all installations.**

PIC. 22

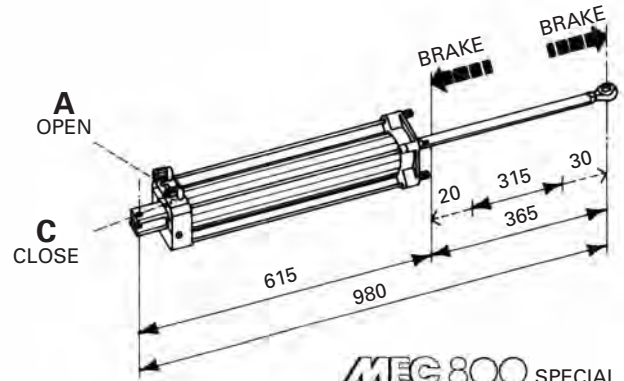

MEC 800 SPECIAL
400 mm - Braking open/close
DRWG. No. 2437

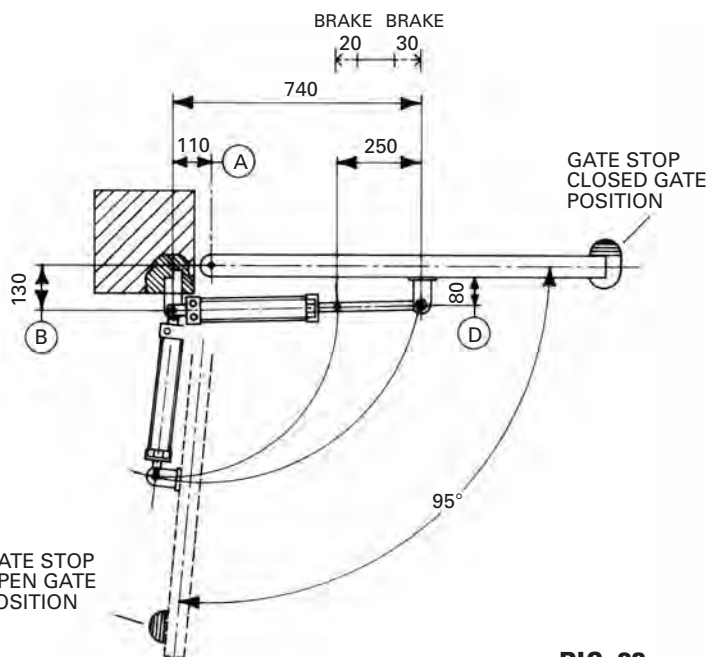

PIC. 23

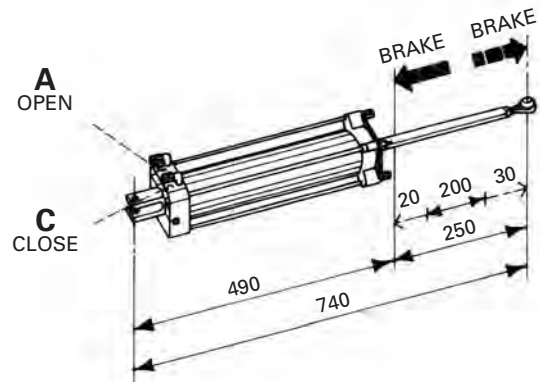

MEC 800 SPECIAL
280 mm - Braking open/close
DRWG. No. 2436

GENERAL DIAGRAM OF THE SYSTEM COMPLETE WITH ACCESSORIES

- 1 - 230 V/240 V - 50 Hz/60 Hz - line switch
- 2 - Control panel Elpro 13 CEI
- 3 - Radio receiver Astro 40 Aut
- 4 - Aerial Astro 40 Aut
- 5 - Flashing light Lapi 2 with protection cage
- 6 - 4 - way pipe connecting block
- 7 - Oil-hydraulic actuator MEC 800 Special
- 8 - Digital keypad Edi 60 outside the gate
- 9 - Electric lock
- 10 - Photocell receiver Difo 33 outside the gate
- 11 - Photocell light projector Difo 33 outside the gate
- 12 - Push buttons Pulin 3 "indoor" commanding unit table mount
- 13 - Oil-hydraulic motor pump MEC 700/80 Ventil enlarged oil capacity
- 14 - 6 - way pipe connecting block
- 15 - Gate stop close position
- 16 - Gate mechanical latch
- 17 - Gate stop open position
- 18 - Keyswitch Sech 15 inside the gate
- 19 - Double mount post, two holes - 1,20 mt
- 20 - Photocell light projector Difo 33 inside the gate
- 21 - Hand held transmitter Astro 40 Aut
- 22 - Photocell receiver Difo 33 inside the gate
- 23 - Single mount post, one hole - 0,75 mt

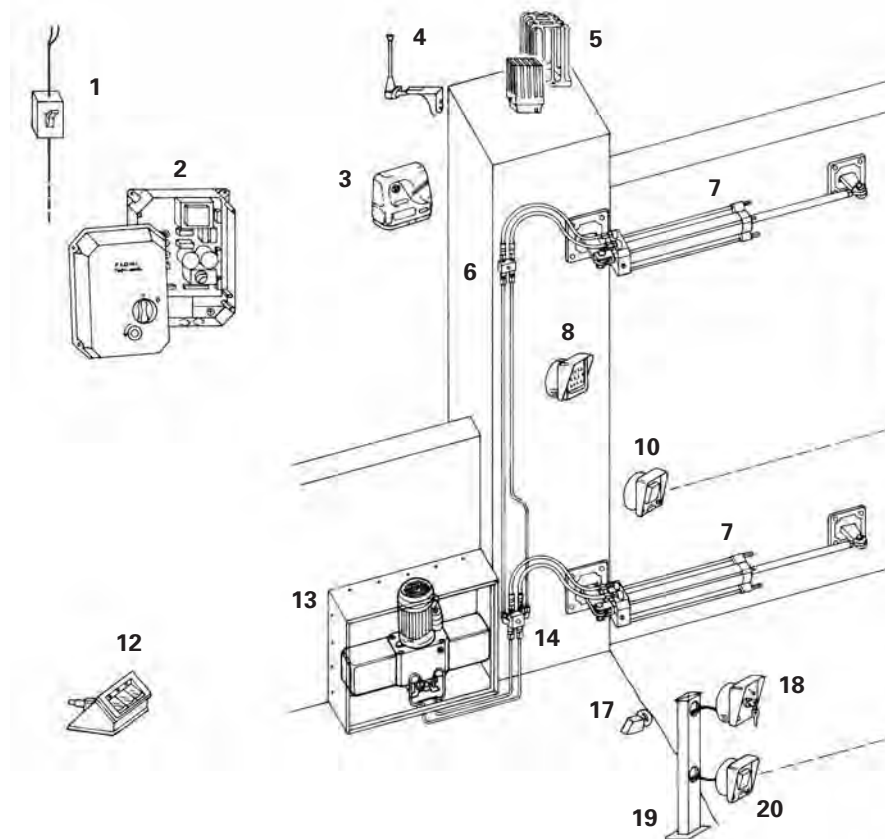

PIC. 24

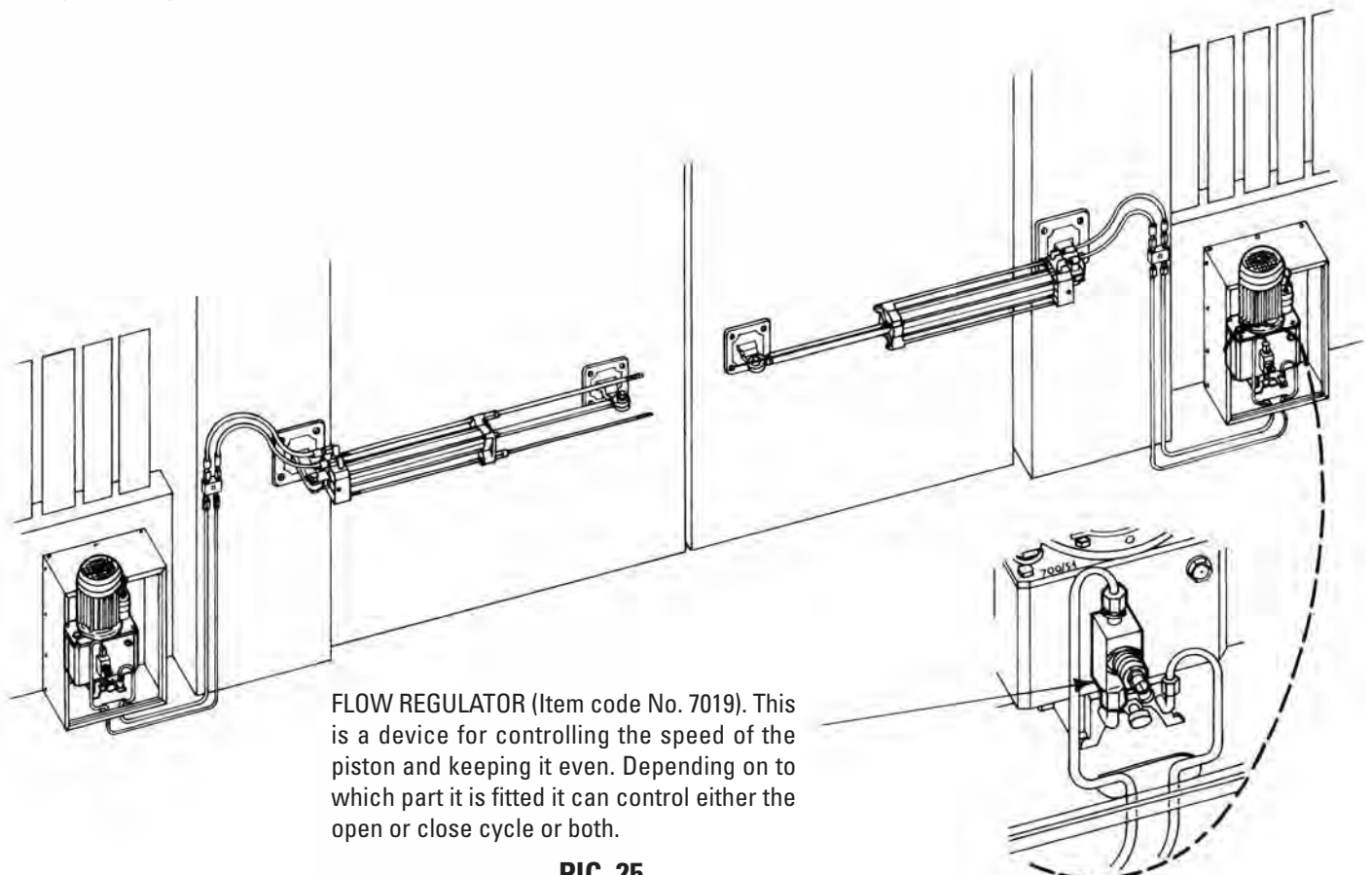

FLOW REGULATOR (Item code No. 7019). This is a device for controlling the speed of the piston and keeping it even. Depending on to which part it is fitted it can control either the open or close cycle or both.

PIC. 25

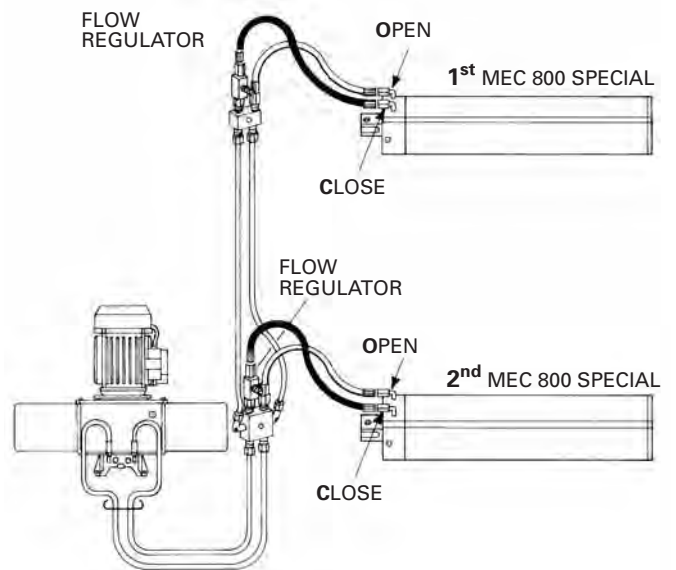
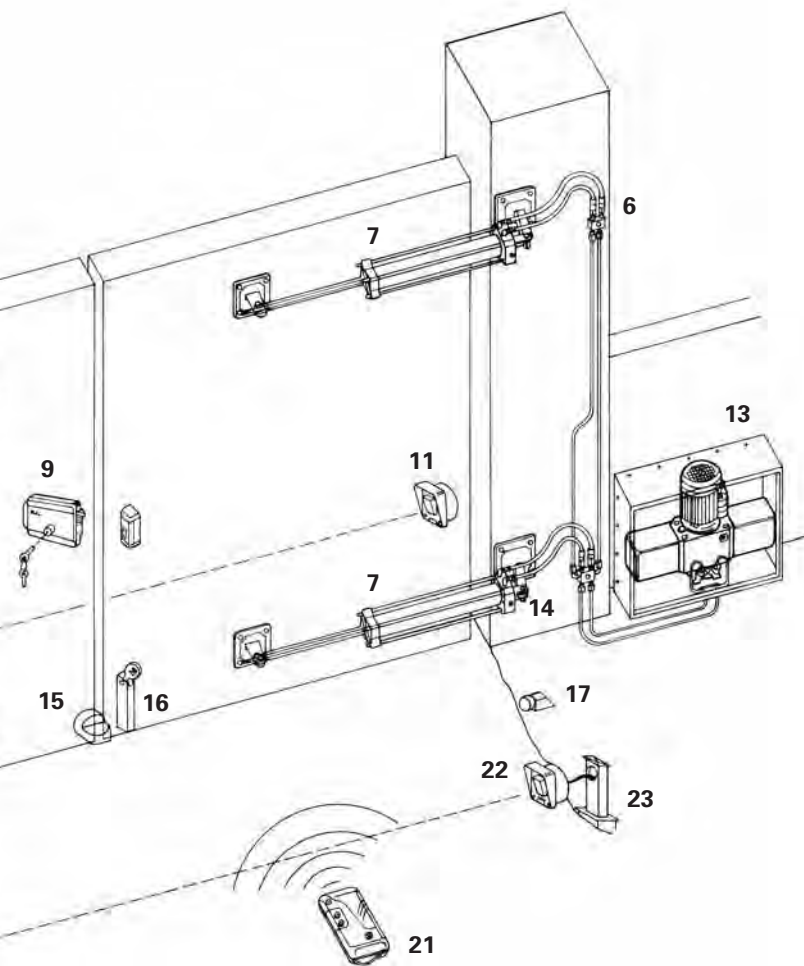

Picture 26 refers to a double mount type installation to note how the flow regulators have been fitted to control the two actuators. In this specific case, the purpose is to slow down one gate leaf to ensure that it reaches the closed gate position after the other one.

PIC. 26

There may be cases where the gates are peculiar and are mounted in the middle of the pillar, post or brick pier; or the gate surface line is aligned with the post horizontal line, or again where the hinges are particular either in the shape or fixing, mounting distances are always to be referred to the centre line of the gate vertical axis of rotation.

At this stage the electrical connections to the electronic control box can be started. Follow the diagram in Pic. 28. Once the connections have been made, do the first switching test to make sure that the leaf delay time, the logic functions, and the motor run time are as required after setting DIP-SWITCH B No. 3 to automatic. If set to semiautomatic one pulse opens the gates, a second pulse is needed to close the gates.

ALL THE EQUIPMENT MUST BE PROPERLY EARTHED

If a non locking motor pump has been fitted, in events like power failure it is necessary to release the electric lock first by means of the provided key as shown in Pic. 13 - 15 and push the gates open by hand applying an even and progressively increasing force.

Beyond 50 m distance the section of the mains cable must be 2.5 mm²

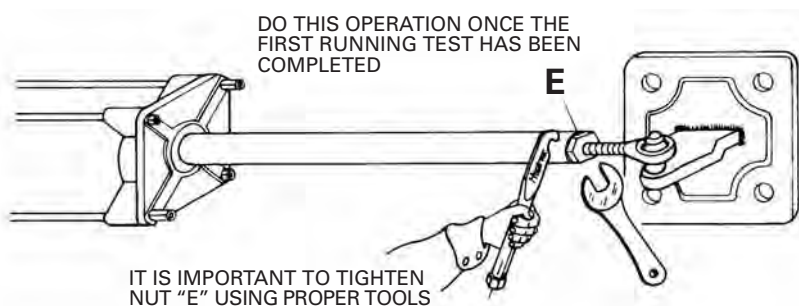

PIC. 27

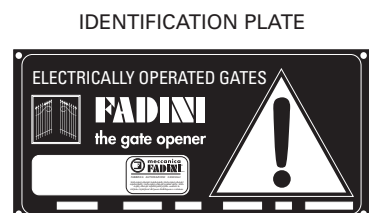

This notice to warn people that they are in proximity of an automated area, therefore the plate must be fitted to the gate in a well visible place.

OVERALL DIMENSIONS

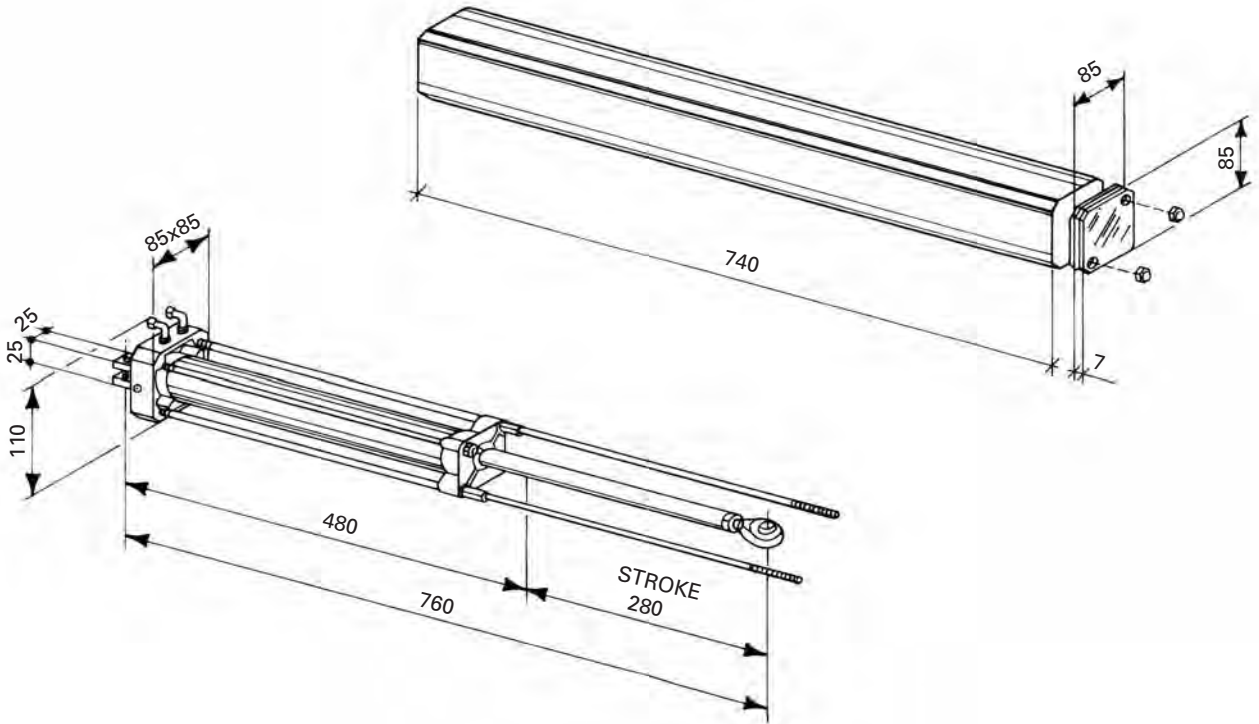

PIC. 30

TECHNICAL SPECIFICATIONS

Oil-hydraulic actuator

Shaft excursion speed	28s
Piston stroke	280 mm
Piston diameter	50 mm
Shaft diameter	22 mm
Max. thrust power. Open	390 Kg
Max. Pulling power. Close	490 Kg
Weight	5,5 Kg
Dimensions (length x width x height)	840x85x110 mm

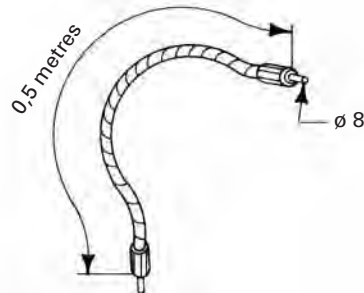

7018 - Flexible tube 0,5 mt

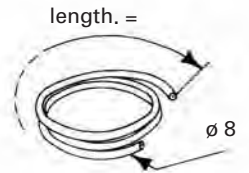

707 - Flexible tube ø 8, mt 4, Kg 1

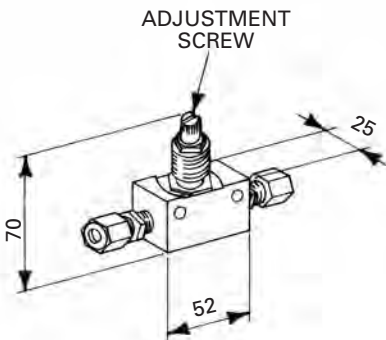

7019 - Flow regulator with joints

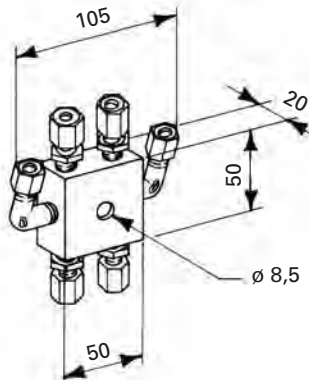

7038 - 6 - way pipe connecting block with joints

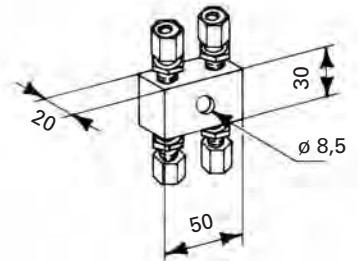

7013 - 4 - way pipe connecting block with joints

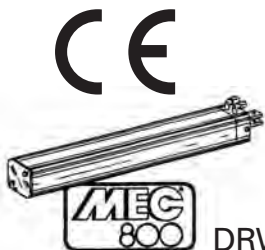

DRWG. No. **1108**

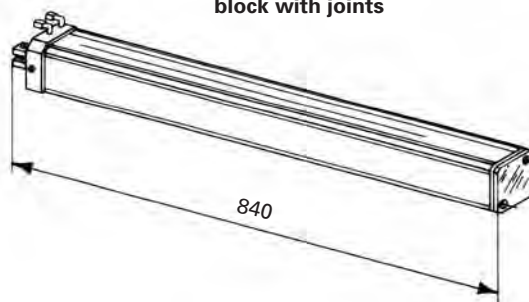

OIL-HYDRAULIC ACTUATOR COMPLETE WITH COVER

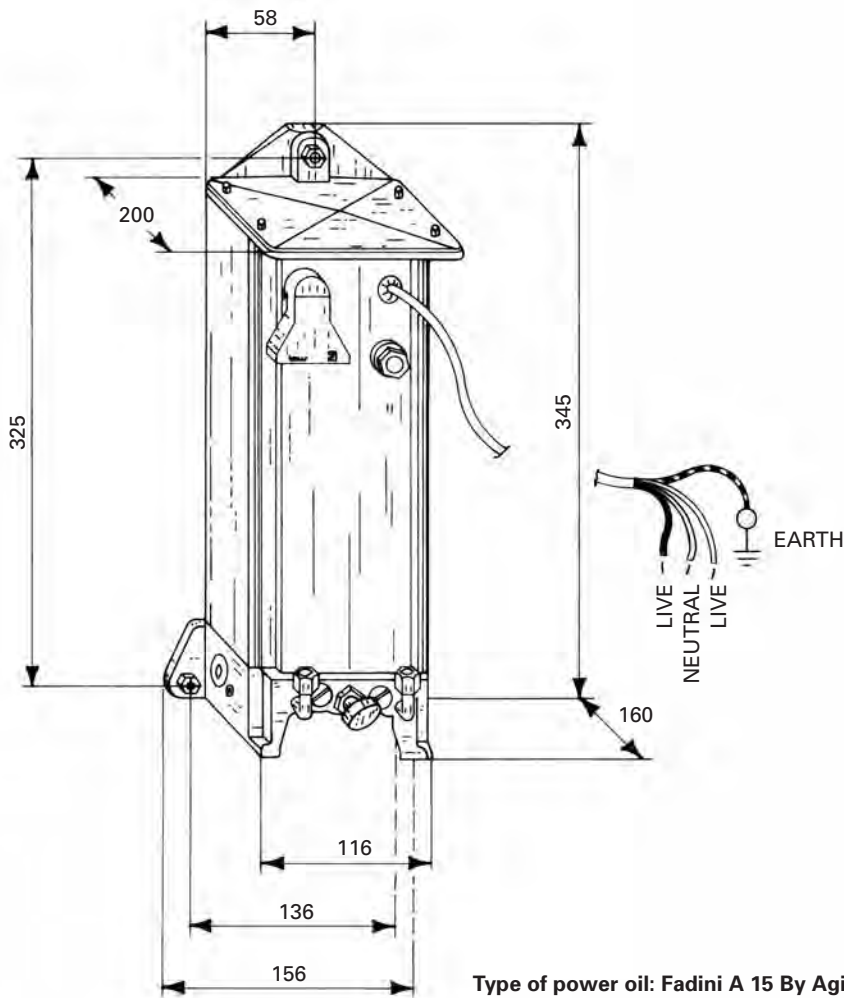

Type of power oil: Fadini A 15 By Agip

PIC. 31

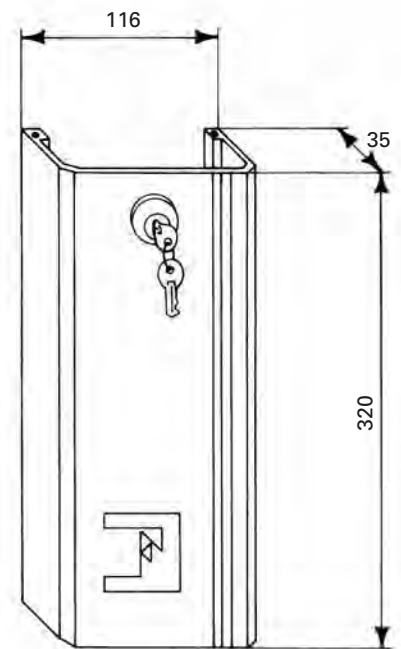

LOCKABLE COVER

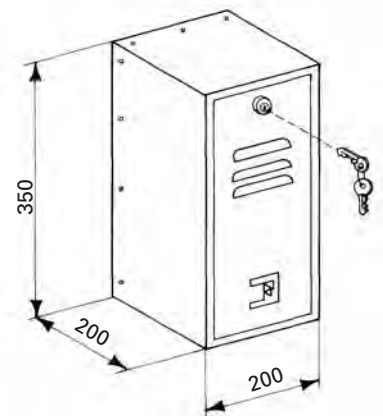

7070 - Enclosure for DRIVE 700 ESTRU galvanized, with lock.

TECHNICAL SPECIFICATIONS

Electric motor

Power output	0,24 KW (0,33 HP)
Supply voltage	230 V
Frequency	50 Hz
Absorbed current	2 A
Absorbed power	400 W
Capacitor	12,5 µF
Motor rotation speed	1'350 r.p.m.
Intermittent service	S3

Oil-hydraulic pump

Pump flow rate P6	1,60 ℓ/min.
Mean working pressure	2MPa (20 bars)
Max. pressure	4MPa (40 bars)
Working temperature	-20°C +80°C
Oil type	OIL FADINI A 15 by AGIP
Oil reservoir capacity	0,95 dm ³
Weight of the assembly	8 Kg
IP protection standards	IP 673

Duty cycle 28 sec. opening - 30 sec. stop - 28 sec. closing
 Time of one complete cycle86s
 Complete cycles - Opening - Stop - ClosingNo. 41/hour
 No. of cycles per year 8 hours' service a day.....No. 122'000

Drive 700 Estru is a motor pump unit, very compact to meet the most various space requirements. Voltage rating, frequency and number of revolutions of the electric motor can vary to meet the customer's requirements. The motor generates and transmits a rotary motion to the lobe pump, which displaces oil in the hydraulic circuit under constant pressure. The pump is designed as a most efficient unit which guarantees a perfect and silent performance of the system. Oil can reverse inside the circuit without any problem. The valve block is fitted with adjustable pressure valves that can be set to the gate weight so that a sufficient amount of power is transmitted to the actuator to safely open and close the gates. In the valve block are also fitted the release valve for manual operation in case of power failure, fittings for piping the system and fixing parts. The design, construction and component parts are such to guarantee this motor pump as a totally sealed unit, fully protected from water, dust and accidents.



OIL-HYDRAULIC MOTOR PUMP MEC 700/80 VENTIL

Electric motor	SINGLE-PHASE	THREE-PHASE
Power output	0,37 KW (0,5 HP)	0,37 KW (0,5 HP)
Supply voltage	230 V	230/400 V
Frequcy	50 Hz	50 Hz
Absorbed current	2,4 A	2,1/1,2 A
Absorbed power	510 W	575 W
Capacitor	20 µF	
Motor rotation speed	1'350 r.p.m.	1'350 r.p.m.
Intermittent service	S3	S1

Oil-hydraulic pump

Pump designation	P3	P6	P12
Flow rate	0,85 l/min.	1,60 l/min.	3,10 l/min.
Mean working pressure	1MPa (10 bars)	2MPa (20 bars)	2MPa (20 bars)
Max. working pressure	3MPa (30 bars)	4MPa (40 bars)	4MPa (40 bars)
Working temperature	-20°C +80°C		
Oil type	OIL FADINI A 15 by Agip		
Oil reservoir capacity.....	2 dm ³		
Motor pump static weight.....	10 Kg		
IP protection standards.....	IP 54		

Duty cycle 28 sec. opening - 30 sec. stop - 28 sec. closing.
 Time of one complete cycle86 s
 Complete cycles - Opening - Stop - ClosingN. 41/hour
 No. of cycles per year 8 hours' service a day.....N. 122'000

Motor pump whit supplementary oil containers

Pump designation	P16
Pump flow rate	3,90 l/min.
Mean working pressure	2MPa (20 bars)
Max. pump pressure.....	4MPa (40 bars)
Working temperature	-20°C +80°C
Power oil type	OIL FADINI A 15 by Agip
Motor pump static weight	16 Kg
IP protection standards	IP 54
Oil capacity	4,5 liters
Empty supplement capacity.....	2,5 liters

Duty cycle: 12 sec. opening - 30 sec. stop - 12 sec. closing
 Time of one complete cycle54 s
 Complete cycles - Opening - Stop - ClosignN. 66/hour
 No. of cycles per year 8 hours' service a day.....N. 194'000

MEC 700/80 Ventil is an oil-hydraulic motor pump fitted with the new "lobe" pump; this unit is capable of very quiet operations and can assure constant oil pressure at 40 bars, heavy duty. The air-cooled electric motor, 1'350 r.p.m., is designed to maintain the power at the required constant rate for heavy duty, right-hand/left-hand operations without variation in oil pressure rating. The motor and the pump are coupled together by means of an elastic joint that is fitted between the two rotation shafts. It provides an ideal shock mount to absorb the kickbacks of the electric motor when rotation is reversed in order to pressurize oil in the opposite direction either to the right or left of the hydraulic circuit. The valve block provides a fixing base to the whole assembly, ie. the motor and pump, and incorporates two safety pressure valves and a locking device in the shape of a cylindrical shuttle. The purpose of this device is to provide a hydraulic lock in the oil circuit both in the open and close directions. Between the two pressure valves is the manual release device. When the electric motor is switched off (stopped) the hydraulic circuit can be released so that the unit is set for manual operations. The valve block is also available in the option without locking device. The motor pump unit is set to either locking or non locking during assembling phase. There are three different types of lobe pumps, depending on the specific component parts that make up the pump assembly. The flow rate, ie. the amount of fluid that each pump can displace under pressure, can be varied to meet the application requirements.

7016 - Enclosure to suit the oil-hydraulic motor pump MEC 700/80 VENTIL

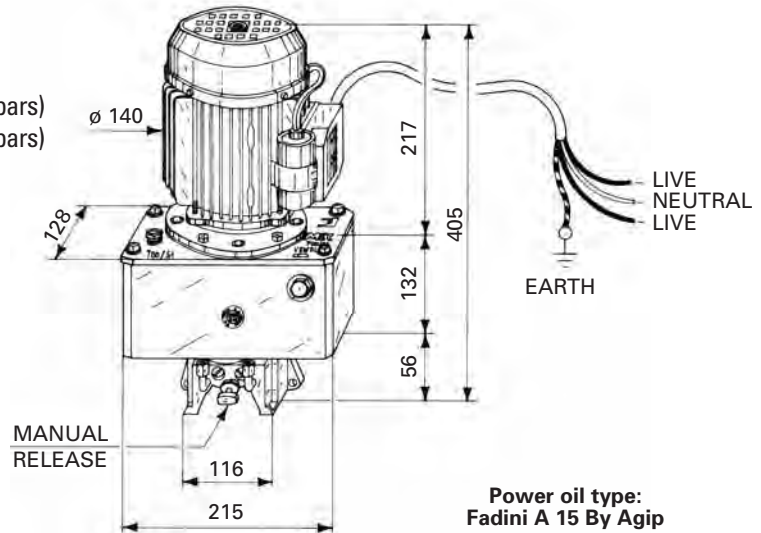
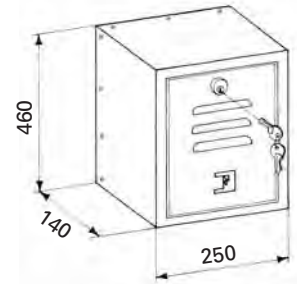

Power oil type: Fadini A 15 By Agip

PIC. 32

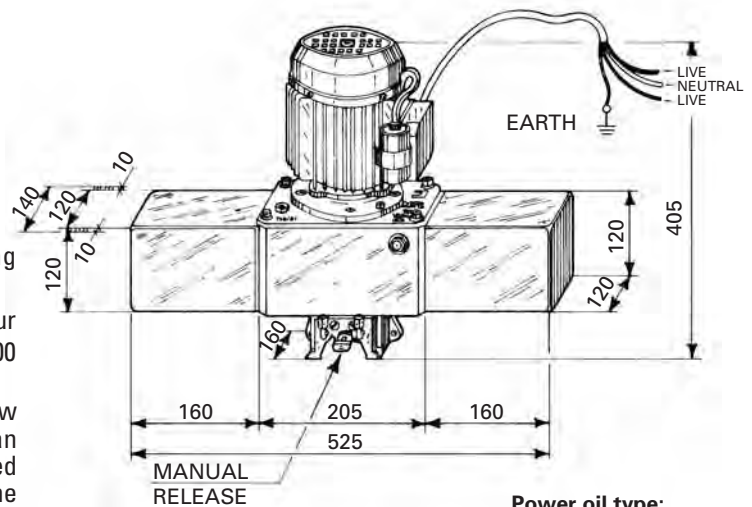

Power oil type: Fadini A 15 By Agip

PIC. 33

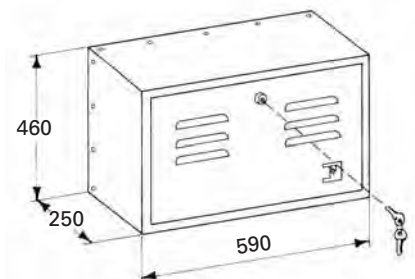
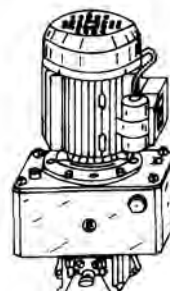

7025 - Enclosure to suit the motor pump unit with supplementary oil containers.



<small>Via Mantova, 177/A - 37053 Cerea (VI) Italy - Tel. 0442/330422 r.a. - Fax 331054</small>			
MOTOR	2 PHASE		
W	400	HP	0,33
VOLT	230	A	2
Rev./min.	1350	Hz	50
Nm	1,7	µF	12,5
Protection Standards IP 673			
Working pressure max. 3 MPa (30 Bars)			
OIL FADINI A15 BY AGIP		CE	
MADE IN ITALY			

Data sticker electric motor

<small>Via Mantova, 177/A - 37053 Cerea (VI) Italy - Tel. 0442/330422 r.a. - Fax 331054</small>			
MOTOR	2 PHASE		
W	510	HP	0,5
VOLT	230	A	2,4
Rev./min.	1350	Hz	50
Nm	2,6	µF	20
Protection Standards IP 54			
Working pressure max. 3 MPa (30 Bars)			
OIL FADINI A15 BY AGIP		CE	
MADE IN ITALY			

Data sticker electric motor

WARNINGS

- Perform a Risk Analysis before every installation and resolve risks through the use of safety devices in compliance with EN 12445 and EN 12453 safety standards
 - Follow the instructions provided
 - Check that the information on the electric motor plate conforms to the distribution network
 - Dispose of all cardboard, nylon, polystyrene and other packaging with specialized waste disposal firms
 - If removing the actuator, **do not cut** the electric wires, but disconnect them from the terminal box by loosening the screws inside the junction box
 - Disconnect the mains switch before opening the electrical wire junction box cover
 - The whole automation should be earthed with the yellow/green wire
 - CUSTOMER GUARANTEE CERTIFICATE ON CUSTOMER'S REQUEST
- We recommend reading the "warning" regulations, suggestions and observations in this booklet very carefully.

Meccanica Fadini recommends the control panel **ELPRO 13 CEI** for installations in conformity to the existing safety standards. The electronic programmer "ELPRO 13" incorporates and can provide all the functions which are required by the most demanding applications with swinging gates. In addition to the features of a conventional control box type Elpro 9 (drwg. 1310), the following requirements can be provided: "stroke reversing pulse", pedestrian mode, stop in any gate position by holding down the remote control button. Among the added features and improvements of "ELPRO 13", in conformity to the European safety standards, there is the mains rotary switch: it is fitted to the box cover and switches off the mains voltage whenever the cover is removed.

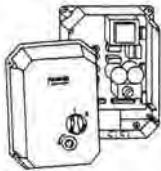

Elpro 13 CEI
CUT OFF
MAINS SWITCH

CE EUROPEAN MARK CERTIFYING CONFORMITY TO THE ESSENTIAL REQUIREMENTS OF THE STANDARDS 98/37/EC

- DECLARATION OF CONFORMITY
- GENERAL WARNINGS
- EN 12453, EN 12445 STANDARDS
- CEI EN 60204-1 STANDARDS
- WARRANTY CERTIFICATE ON THE CUSTOMER'S REQUEST

The "CE" mark certifies that the operator conforms to the essential requirements of the European Directive art. 10 CEE 73/23, in relation to the manufacturer's declaration for the supplied items, in compliance with the body of the regulations ISO 9000 = UNI EN 29000. Automation in conformity to EN 12453, EN 12445 safety standards.



AUTOMATIC GATE MANUFACTURERS

INSPECTIONS AND MAINTENANCE

- In order to ensure optimal system performance over time and so as to comply with current safety standards, it is necessary to follow the correct maintenance and monitoring procedures for the entire automation, electronic devices and wiring:
- Oil-hydraulic automation: maintenance inspection around every 6 months
 - Electronic devices and safety systems: maintenance inspection monthly

IMPORTANT WARNING NOTES

- It is recommended to keep to the instructions here outlined - check the specifications on the motor sticker with your mains supply.
- Dispose properly of the packaging materials such as cardboard, nylon, polystyrene etc. through specializing companies.
- Switch off the mains power switch before removing the cover of the motor pump enclosure.
- All the system must be earthed by using the yellow/green wire, marked by its specific symbol. - It is recommended to read the regulations, suggestions and remarks quoted in the booklet "Warnings".
- Before removing the ram, make the oil flow back to the reservoir in the motor pump unit through the release system; should the motor pump be removed, too for service or maintenance, plug the pipe joints to prevent oil from coming out during transport.

The growth of MECCANICA FADINI has always been based on the development of guaranteed products thanks to our "TOTAL QUALITY CONTROL" system which ensures constant quality standards, updated knowledge of the European Standards and compliance with their requirements, in view of an ever increasing process of improvement.



FADINI
the gate opener
Made in Italy



**ECOLOGICAL
RECYCLING**

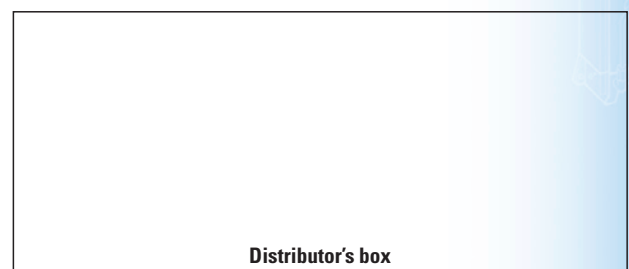

Distributor's box

The manufacturers reserve the right to change the products without any previous notice