

mission



*Mission Zero:*  
our promise to eliminate  
any negative impact our company  
may have on the environment  
by the year 2020.

# INSTALLATION MANUAL

# Contents

<b>01</b>	<b>BEFORE STARTING</b>	page <b>3</b>
<b>02</b>	<b>CONDITIONING OF MATERIALS</b>	page <b>3</b>
<b>03</b>	<b>FLOOR PREPARATION</b>	page <b>3</b>
<b>04</b>	<b>INSTALLATION SET OUT</b>	page <b>5</b>
<b>05</b>	<b>ANTI-SLIP COMPOUND – INTER-TAC®</b>	page <b>7</b>
<b>06</b>	<b>APPLICATION OF ADHESIVE</b>	page <b>7</b>
<b>07</b>	<b>TACTILE</b>	page <b>7</b>
<b>08</b>	<b>TACTILE PLACEMENT</b>	page <b>8</b>
<b>09</b>	<b>TACTILE SUBFLOOR PREPARATION REQUIREMENTS</b>	page <b>9</b>
<b>10</b>	<b>UNDERFLOOR HEATING</b>	page <b>9</b>
<b>11</b>	<b>LAYING DIRECTION</b>	page <b>10</b>
<b>12</b>	<b>COMMENCING THE INSTALLATION</b>	page <b>10</b>
<b>13</b>	<b>ACCESS FLOORING</b>	page <b>11</b>
<b>14</b>	<b>STAIRS</b>	page <b>11</b>
<b>15</b>	<b>INSTALLING FIXTURES &amp; FURNITURE AFTER MODULAR CARPET INSTALLATION</b>	page <b>11</b>
<b>16</b>	<b>FINISH</b>	page <b>12</b>
<b>17</b>	<b>CONCLUSION</b>	page <b>12</b>
<b>18</b>	<b>CUSHIONBAC MODULAR CARPET</b>	page <b>12</b>
<b>19</b>	<b>UNBACKED SHEET GOODS</b>	page <b>12</b>
<b>20</b>	<b>INSTALLATION OVER UNDERLAY SYSTEM 6+ 1M X 1M IMPERVIOUS SYSTEM</b>	page <b>13</b> page <b>14</b>

# Appendices

<b>01</b>	<b>CONCRETE SUBFLOOR REQUIREMENTS</b>	page <b>17</b>
<b>02</b>	<b>INTERFACEFLOR INSTALLATION METHODS AND CODES</b>	page <b>18</b>

# Introduction

This manual has been prepared by the InterfaceFLOR technical division to assist professional contractors and layers in the installation of InterfaceFLOR modular carpet.

These instructions cover the most common installation circumstances. If a particular installation condition is not covered, the contractor should contact an InterfaceFLOR representative.

If InterfaceFLOR modular carpet is installed before construction is complete, any resulting staining, soiling, contamination or damage caused by building construction may void the end user's product warranty. The contractor should inform the appropriate person of this warranty implication.

## 01 BEFORE STARTING

It is the responsibility of the contractor to verify, before the installation, that material supplied conforms to owner's specifications, including correct product, colour and quantity.

Labels on each carton contain important information including: product, colour and manufacturing batch (dye lot information).

It is not recommended to mix dye lots in the same area, with the exception of the i2™ collection of products as they possess mergable dye lots.

Take particular notice of installation codes printed on cartons as this indicates the manufacturers' recommended installation method. However the client's preferred installation method should be confirmed and signed off by the installer before commencement of installation.

## 02 CONDITIONING OF MATERIALS

The installation location and all products and materials used in the installation, must be at temperature between 15 degrees C – 35 degrees C for a period of 48 – 72 hours before the installation begins. The temperature must remain within this range throughout the installation. Relative humidity in the area should be 45% ± 10%.

## 03 FLOOR PREPARATION

The subfloor must be rigid, dry, smooth, flat, level, sound, clean and free from harmful materials. When installing GlasBac® modular carpet products, no bitumen based substance must come in contact with the GlasBac backing.

The subfloor must be rigid to stop modular carpet from cupping.

Old carpet, under felt, loose laid vinyl, cushion backed vinyl and any old adhesive must be removed and floor scraped clean.

**A clean floor** – Floor should be free from all dirt, dust and harmful materials. Before applying Intertac the subfloor should be swept or vacuumed to remove all dust. Concrete or timber floors must be primed with an approved primer such as Roberts 370 or Polymer 6000 before application of Intertac.

**A dry floor** – All floors must be dry. New concrete floors must be checked for moisture as per AS2455 2007. Moisture content must not exceed levels indicated in Appendix 1. If the moisture content is above the recommended maximum readings STOP and DO NOT PROCEED with the installation. Seek further advice from InterfaceFLOR before proceeding.

**A low pH floor** – The subfloor should have an alkalinity level of between pH7 & pH9 to be suitable for carpet installation. Test by wetting the floor with distilled water then using a pH test paper or meter. Should the pH level be outside this range STOP and DO NOT PROCEED with the installation. Seek further advice from InterfaceFLOR before proceeding.

## Identify the Type of Floor

**New concrete floors** – Must be smooth and level as per Appendix 1.

**Old concrete floors** – Remove paint, sealer, grease, oil, adhesive and any harmful materials, especially bituminous based substances which are not compatible with GlasBac modular carpet products. All existing adhesive must be removed from the floor. Fill and level all cracks and holes. Bring surface up to specification as in Appendix 1 using an approved latex levelling compound eg. Ardex K15 or equivalent, in accordance with manufacturer's directions. This levelling compound needs to be compatible with the backing system.

Any existing carpet, under felt, loose laid vinyl, cushion back vinyl and all existing adhesive must be removed and the floor scraped clean.

**Vinyl Tiles** – Damaged & loose vinyl tiles must be replaced or patched and all existing wax coated products are to be removed. Any existing bituminous based adhesive or underlay are to be removed when installing GlasBac modular carpet products.

Ensure that the bond between vinyl tiles and subfloor will last the service life of the modular carpet.

If a sealer is used, any reaction shall be the contractor and end-user's responsibility.

**Ceramic and quarry tiles** – All joints are to be filled and levelled as per Appendix 1. Use rough Sandpaper to remove surface glaze.

**Wood Floors** – Unless the subfloor is free from grooves, ridges, gaps, holes or similar imperfections, the use of a hard underlay is recommended.

**Underlay** – The underlay should be either reduced density, as per AS2458 medium density fibre board types MDF and MDFMR in accordance with BS1142, or medium density fibrous cement sheet known as hard underlay. The underlay and the fixing material must be compatible with the InterfaceFLOR modular carpet and Inter-Tac adhesive. Installation shall be in accordance with the underlay manufacturer's instructions.

**Sealer / Moisture Barrier** – If a sealer is used on a concrete floor it must be compatible with vinyl and can be either a solvent or water based sealer which can be acrylic, epoxy, urethane or chlorinated rubber. Sealers must also be used in accordance with manufacturer's directions. If in doubt, coat sealer on back of the tile and leave overnight. It is not suitable for use if it remains sticky.

An example of a suitable product to use for a hydrostatic moisture problem would be Ardex WPM 300 Two Pack Epoxy or for a green slab – Ardex Green Slab Seal.



NOTE: WHEN INSTALLING NON IMPERVIOUS BACKED FLOOR COVERINGS, WATER BASED ADHESIVES, APART FROM PRESSURE SENSITIVE ADHESIVES, CANNOT BE USED ON A SEALED FLOOR.





NOTE: WHERE PRACTICAL THERE SHOULD BE UNCUT MODULAR CARPET TILES IN DOORWAYS AND HIGH TRAFFIC AREAS.

## 04 INSTALLATION SET OUT

### General

In setting up, a point in the room shall be determined from which modular carpet can be laid to ensure that they are parallel to the longest wall.

### Procedure

The procedure for setting out shall be in accordance with the following, as shown in Figure 1.

#### Step 1

Mark a line EF parallel to the longest wall.

#### Step 2

Mark point X along line EF at a distance to ensure that the requirements of perimeter modular carpet are a minimum of 1/3 width.

#### Step 3

Mark points J1 and J2 at a distance of 3 m each side of X.

#### Step 4

At J1 and J2 scribe an arc at a distance of 5 m to establish point K where arcs intersect.

#### Step 5

Draw a line through points K and X which will be 90 degrees to line EF.

### Single Room Installation

#### Step 1

Establish two chalk lines at 90 degrees as shown in Figure 1. This line may be established slightly off centre to enable you to meet other requirements, such as placing uncut modular carpet in traffic areas.

#### Step 2

Commencing only at the cross point of the two chalk lines, complete one row of modular carpet on each side of the centre line.

#### Step 3

Anchor your basic installation as shown in Figure 2. Complete the body of the installation by laying in a triangular method.

#### Step 4

Complete the remaining quadrants, section by section.

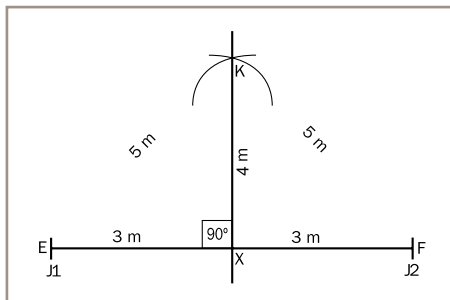

Figure 1

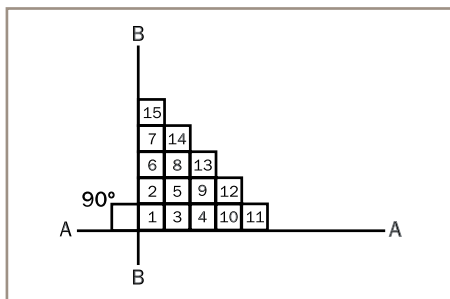

Figure 2





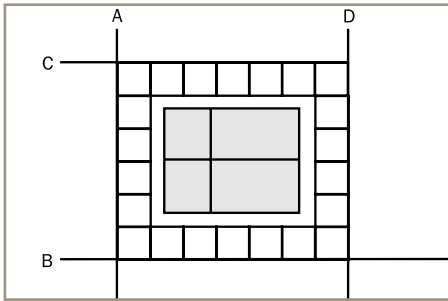

Figure 3a

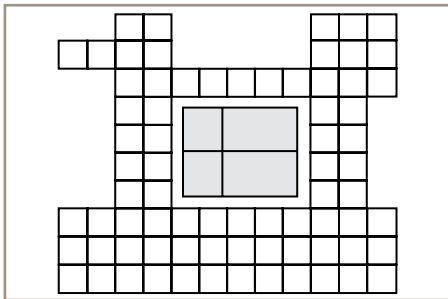

Figure 3b

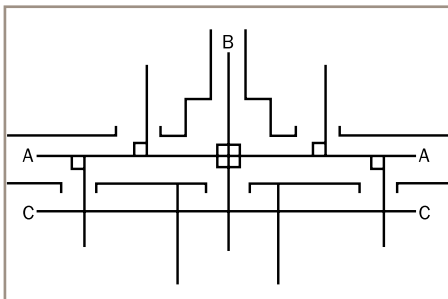

Figure 4

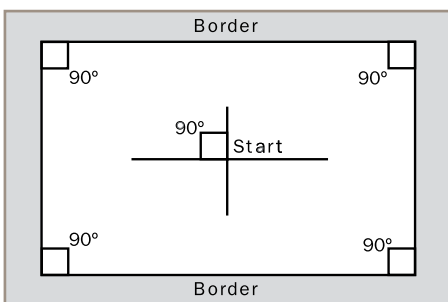

Figure 5

## Large Area with Obstacles

### Example: An Elevator

#### Step 1

Establish your starting point as shown in Figure 3a, with the A-B at 90 degrees.

#### Step 2

Pass your obstacle along line A and B with a minimum of 1 and 1/3 modular carpet. At this point you will establish line C and D, parallel to line B and A.

#### Step 3

Complete modular carpet between A and B. (Notice, only a single row of modular carpet is used for this exercise).

#### Step 4

Continue to anchor your installation. Fill in the remaining quadrants as shown in Figure 3b.

## Office Complex

#### Step 1

The crossover point, centre corridor, centre hall is the starting point for this example as shown in Figure 4. Line A and B should again be at 90 degree angles.

Lay a row of modular carpet on each side along chalk line A. At the entrance of each office passed, a chalk line is projected into that office at 90 degrees. Complete your corridor including cutting.

#### Step 2

Lay the modular carpet into the offices and anchor the installation. This will create line C parallel to line A. The total installation is lined out. Complete the body of installation by laying in a triangular method as shown in Figure 3.

#### Step 3

Complete all cut modular carpet in the corridor, including door ways. Lay and anchor modular carpet along line C. Fill in the remaining parts.

## Borders

Set out chalk lines at the required distance for the border and/or field colour modular carpet. Ensure all 90 degree angles are correct. Use these chalk lines as wall lines and cut modular carpet up to these lines. Cut border modular carpet in from chalk line to compensate for any irregularities in the wall. Refer to Figure 5.





## 05 ANTI-SLIP COMPOUND – INTER-TAC®

NOTE: IF SUBFLOOR IS AN ACCESS FLOOR THAT IS PRONE TO RUSTING THE USE OF TACTILE IS RECOMMENDED.

All InterfaceFLOR modular carpets require 100% application of Intertac unless utilising TacTile or otherwise specified by manufacturer.

Intertac is a low odour, solvent free pressure sensitive adhesive containing Intersept. (InterfaceFLOR anti-microbial additive)

The subfloor should be prepared to AS:2455 requirements.

An approved primer such as Roberts 370 or Polymer 6000 must be used on all porous surfaces.

Before application of Intertac the subfloor should be vacuumed and washed to remove all dust from the subfloor.



## 06 APPLICATION OF ADHESIVE

NOTE: TACK OFF TIME WILL ALSO BE LONGER AND RELEVANT TO HUMIDITY IN THE WORK AREA AND GENERAL SITE CONDITIONS.

Inter-Tac is a pressure sensitive compound. Application is by long nap paint roller. Rate of application is 10m<sup>2</sup> to 14m<sup>2</sup> per litre, depending on the porosity of the subfloor. On non-porous floors the rate of application will change and a spread rate greater than 14m<sup>2</sup> per litre may be obtained in some cases.

NOTE: A NEW LONG NAP ROLLER SHOULD BE USED AT THE START OF EACH INSTALLATION.

It is mandatory that Inter-Tac must tack up before use. Colour must change from green to clear and it must not transfer.

NOTE: IN CERTAIN CONDITIONS A STRONGER BOND TO THE SUBFLOOR MAY BE REQUIRED. FOR A STRONGER BOND THE TILE CAN BE INSTALLED INTO SEMI-TACKED UP INTERTAC ADHESIVE ALLOWING FOR SOME ADHESIVE TRANSFER TO OCCUR.

Users assume all risk and liability resulting from the use of Inter-Tac. It is recommended that users carry out project specific trials to confirm the suitability and application of Inter-Tac.

**Note:** Tack off time will also be longer and relevant to humidity in the work area and general site conditions.

**Note:** A new long nap roller should be used at the start of each installation.

**Note:** In certain conditions a stronger bond to the subfloor may be required. For a stronger bond the tile can be installed into semi-tacked up Intertac adhesive allowing for some adhesive transfer to occur.



## 07 TACTILES™

NOTE: WHEN USING TACTILE IN A GLASBAC INSTALLATION THE TACTILE IS USABLE FOR TWO INSTALLATIONS AFTER WHICH A NEW TACTILE SHOULD BE USED.

**Glasbac & GlasbacRE** – TacTiles can be used in the installation of both GlasBac and GlasBacRE carpet tile. To lift existing carpet tiles simply peel the carpet tile from the TacTile and fit a new carpet tile to the existing TacTile.

NOTE: WHEN USING TACTILE IN A GRAPHLAR INSTALLATION THE TACTILE WILL REQUIRE REPLACEMENT FOR EACH INSTALLATION CHANGE.

**Graphlar** – TacTile can be used in the installation of Graphlar carpet tile. To lift a Graphlar tile simply run a sharp knife along the tile edge and cut through the TacTile. Leaving the existing TacTile adhered to the carpet tile backing, lift the carpet tile from the floor and fit a new TacTile to the corner. The new Graphlar carpet tile can then be installed.

TacTile can be installed directly over wood, ceramic, marble and stone floors with minimum floor preparation as long as moisture and pH levels are within InterfaceFLOR recommendations.

Once the installation is completed and then maintained in line with InterfaceFLOR installation and maintenance recommendations TacTiles will be effective for the life of the installation providing they are not removed or replaced.



NOTE: A TACTILE MUST BE APPLIED UNDER EVERY CUT TILE ABUTTING THE FIELD TILES.

**Rolling Loads** – TacTiles can be used under areas that will be subjected to normal commercial rolling load applications. Eg: Castor Chair, Hand Trolleys or similar.

For areas that will be subjected to heavy rolling loads such as pallet trolleys, fork lifts, scissor lifts, etc, please contact InterfaceFLOR Technical Services for project specific advice.

**Ramps** – TacTile is not recommended for use on ramped floor areas. The use of Intertac pressure sensitive adhesive is recommended when installing modular tile to ramped floor areas.

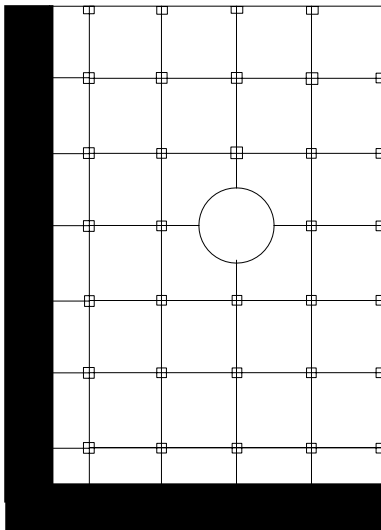

## 08 TACTILE PLACEMENT

### For Quarter Turn / Monolithic / Non Directional Installation methods

A TacTile should be placed under every corner of each tile across the installation area and all cut tiles abutting the field tiles.

### For Brick or Ashlar Installation methods

A TacTile should be placed on every other corner across the installation area and all cut tiles abutting the field tiles.

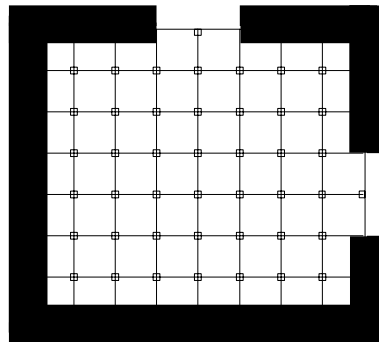

*Quarter-Turn / Monolithic / Non-Directional Installation methods will require 4 TacTiles per square metre*

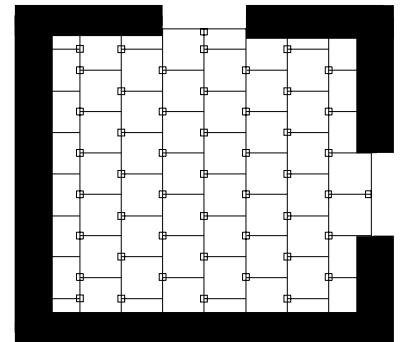

*Brick or Ashlar Installation methods will require 4 TacTiles per square metre*

TacTiles should be applied based on the following diagrams.

### TacTiles

**Note:** TacTiles are not recommended for installation of carpet tiles to stairs

**Note:** A TacTile must be applied under every cut tile abutting the field tiles.

#### Note: Glasbac & GlasbacRE Tile

TacTiles will be effective for the life of the installation providing they are not removed or replaced.

Where carpet tiles are replaced TacTiles will only be effective for 2 installation changes after which they need to be replaced to maintain the integrity of the installation.

#### Note: Graphlar Tile

TacTiles will be effective for the life of the installation providing they are not removed or replaced.

Where carpet tiles are replaced TacTiles will require replacement for each installation change to maintain the integrity of the installation.





## 09 TACTILE SUBFLOOR PREPARATION REQUIREMENTS

NOTE: IF THE SUBFLOOR EXCEEDS THE REQUIRED MOISTURE AND PH REQUIREMENTS THE INSTALLATION OF A BARRIER COAT IS RECOMMENDED TO PREVENT FUTURE ISSUES FROM RISING MOISTURE AND PH.

FAILURE TO CARRY OUT THE CORRECT SUBFLOOR PREPARATION OR REMEDIAL WORKS MAY RESULT IN VOIDING OF THE PRODUCT WARRANTY.

The subfloor requirements for a TacTile installation are the same as for any adhesive installation.

Please consult your InterfaceFLOR Installation manual for detailed recommendations.

TacTile can be installed directly over wood, ceramic, marble and stone floors with minimum floor preparation as long as moisture and pH levels are within InterfaceFLOR recommendations.

### Notes on Subfloor Moisture and pH requirements

#### Moisture Content

Dependent on the testing method used the subfloor needs to be classified as "DRY"

#### Test Methods

##### Calcium Chloride Test

Required to be measured in pounds of moisture over a 1000 ft<sup>2</sup> area during a 24 hour period. An emission rate of 3.0 lbs. (1.4 kg) or less is acceptable

##### Hydrometer

Required to be 70% rh or less

##### Electrical Resistance Meter

Required to be 5.5% or less.

##### Subfloor pH requirement

The subfloor pH should be tested with a result of no more than pH 9.

## 10 UNDERFLOOR HEATING

InterfaceFLOR modular carpet may be installed on internally heated floors provided that the surface temperature will not exceed 27 degrees C.

Underfloor heating must be turned off 48 hours prior to commencement of installation and shall not be turned on again until 48 hours after installation is completed to allow the adhesive to set.



## 11 LAYING DIRECTION

All InterfaceFLOR modular carpets should be installed as per the directions printed on the carton. Installation methods & codes printed on the cartons are:

<b>DIR</b>	Directional
<b>QTR</b>	Quarter Turn
<b>RDM</b>	Random
<b>SPEC</b>	Specification Methods. (Refer to diagrams on inside back cover)

If SPEC code appears on the carton please confirm with the client their preferred installation method.

It is the installers responsibility to confirm the installation method prior to commencement on installation.



NOTE: ALL NEEDLE PUNCH PRODUCTS MUST BE INSTALLED QUARTER TURN.

## 12 COMMENCING THE INSTALLATION

Apply Inter-Tac as recommended. Lay one row of modular carpet down each side of the chalk line, then install the modular carpet using the stair method. This will quickly pin point if the grid is running out of alignment.

### Alignment

As modular carpet is butted against each other, continually check (with fingers) that the joints are properly aligned. Do not install modular carpet that is out of square by more than 1mm.

### Tension

Ensure an even tension throughout the installation as this is vital to the overall appearance.

Lack of tension and pile entrapment may cause poor performance and will impair the appearance of the finished installation.

Over tension of the installation may cause peaking of the tile.

The cumulative space gained in GlasBac or Graphlar® modular carpet products should be 5mm, measured over 11 modular carpet squares (10 joins). Any gain less than this may cause peaking and or buckling.

### Cutting

All InterfaceFLOR modular carpet must be cut from the backing side by overlaying the modular carpet, marking and cutting. A template should be used around columns.

**Step 1** Firstly effect a light cut without attempting to cut right through.

**Step 2** Then crack the modular carpet along the line cut.

**Step 3** Complete by cutting right through the fibres with a straight utility or hook knife.



NOTE: MODULAR CARPET CUT ON AN ANGLE OR A CUT EDGE THAT IS EXPOSED TO HEAVY FOOT OR WHEELED TRAFFIC MAY NEED TO BE SEALED WITH LATEX.

NOTE : WHEN ABUTTING INTERFACEFLOR CARPET UP TO A HARD SURFACE FINISH OR EDGE TRIM THE TOP OF THE CARPET PILE SHOULD BE LEVEL WITH THE TOP OF THE HARD SURFACE OR EDGE TRIM. IF THE CARPET PILE SITS HIGHER THAN THE HARDSURFACE OR EDGE TRIM AND IS EXPOSED TO HIGH LEVELS OF TRAFFIC THIS MAY CAUSE DAMAGE TO THE CARPET EDGE.

## 13 ACCESS FLOORING

### On Grid Access Flooring Installation – GlasBac®OG 600 x 600mm modular carpet

The installation of GlasBacOG differs from traditional on grid carpet laying in that you **do not** butt up the tiles to each other. Instead, installation is by placing the modular carpet locating buttons (attached to the backing) into the matching positioning holes on the access panel. Inter-Tac adhesive is not required. The locating buttons limit movement of tiles on the access panels.

### Off Grid Access Flooring Installation – 500 x 500mm modular carpet

On access floors, off grid installation will mean that the edge of the modular carpet does not correspond with access floor panel joints.

Installation as per standard InterfaceFLOR modular carpet installation instructions.

Intertac adhesive and TacTile are both suitable for modular tile installation over access flooring.

On access floors an application rate for Intertac of over 14m<sup>2</sup> may be achieved in some cases.



NOTE: ON ACCESS FLOORS AN APPLICATION RATE FOR INTERTAC OF OVER 14 M<sup>2</sup> MAY BE ACHIEVED IN SOME CASES.



NOTE: IT IS IMPORTANT TO BRING THE MODULAR CARPET RIGHT UP TO THE UNDERSIDE OF THE NOSING, FLUSH WITH THE TREAD, AS THIS WILL SUPPORT THE LEADING EDGE OF THE NOSING AND PREVENT IT ROCKING AND COMING LOOSE. DO NOT BEND MODULAR CARPET OVER THE EDGE OF STAIR STEPS.

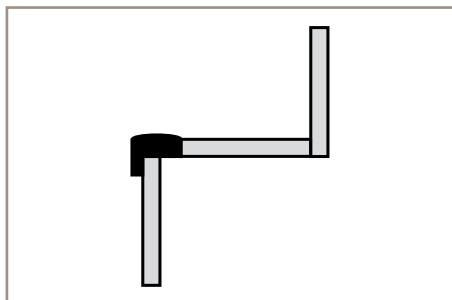

## 14 STAIRS

### Stairnosing

**InterfaceFLOR modular carpet cannot be installed over the nose of a stair. A metal or rubber nosing must be installed.**

#### Riser

Apply Inter-Tac to both the tile backing and the riser.

Allow Inter-Tac to tack up and place carpet for the riser in position.

#### Tread

Apply Inter-Tac to 100 per cent of tread.

The tread should be fitted after the riser to allow the tread carpet to hold the riser securely in position.

## 15 INSTALLING FIXTURES & FURNITURE AFTER MODULAR CARPET INSTALLATION

To avoid dislodging modular carpet during furniture and fixture placement, place standard sheets of plywood or cardboard over the complete installation.

If plastic type protection is used, any condensation is the responsibility of the contractor. Do not position adhesive tape on pile of modular carpet.



IT IS RECOMMENDED THAT ALL 12TH GAUGE PRODUCTS BE CHECKED THOROUGHLY FOR TUFT SPROUTS AND THAT ANY NOTICEABLE SPROUTS ARE NAPPED AS PART OF THE FINISHING PROCEDURE.

## 16 FINISH

Edge Restraint – In the event of an open perimeter area a fixed reducer strip anchored to the floor is recommended. The edge restraint should be the same height as the carpet and finish level with the carpet pile ensuring a smooth transition from one surface to the other.

Nap all slivers and tuft sprouts using napping shears.

It is recommended that all 12<sup>th</sup> gauge products be checked thoroughly for tuft sprouts and that any noticeable sprouts are napped as part of the finishing procedure.

Apply a final Vacuum or Pile Lifting process.

Ensure that the overall finished appearance is consistent throughout. Correct any defects including incorrect arrow direction.

Upon completion, a further vacuum or pile lift may be required. It is essential that lighting be in service to allow inspection under good lighting conditions.



ANY VARIANCE FROM ANY OF THESE INSTRUCTIONS WILL BECOME THE RESPONSIBILITY OF THE CONTRACTOR AND NOT THE MANUFACTURER AND SHALL VOID ALL OTHER WISE APPLICABLE WARRANTIES.

## 17 CONCLUSION

These installation procedures are recommended by the manufacturer and installation should only be carried out by experienced and competent carpet installers. Strict adherence to these procedures will result in a quality installation under most conditions. Any situation that can alter the installation procedure, such as the identification of defect material or unusual installation conditions, creates a responsibility for the contractor to notify both the owner and the manufacturer before proceeding.

Any variance from any of these instructions will become the responsibility of the contractor and not the manufacturer and shall void all other wise applicable warranties.

## 18 INTERFACEFLOR CUSHIONBAC™ MODULAR CARPET

Follow the same procedure as outlined for InterfaceFLOR modular carpet.

## 19 INTERFACEFLOR SHEET GOODS – UNBACKED

Apply 100% adhesive such as Roberts 95SF or Polymer 300. If installing to areas that will be subjected to excessive steam cleaning, ie.; hotel bar areas, gaming rooms etc., use adhesive such as Roberts 12SF or Polymer 365.

## 20 INSTALLATION OVER UNDERLAY

### Bridgestone Airstep ‘SuportaPad’ or Dunlop ‘Modulay’ Underlays

Prepare floor as outlined in Section 3, ensuring floor is primed using a product such as Roberts 370 or Polymer 6000 Primer.

#### Adhesion of Underlay to Subfloor

- 1 Before use, the underlay should be removed from its plastic packaging and fully unrolled for a period of no less than four hours. It is preferable that the product be left unrolled overnight.

Decide the position of the datum lines for alignment of modular carpet and offset the starting seam of the underlay by 200mm from this line.

- 2 The underlay should be bonded firmly to the subfloor with a product such as Roberts 656, using a 1.6mm x 1.6mm “V” notched trowel. For example, Roberts Switchblade V1.
- 3 The underlay should then be lowered into the adhesive when “tack up” is evident and rolled with a roller of no more than 25 – 30 kgs. This ensures the underlay is secured to the subfloor. All joints must be close fitting when positioned and excessive rolling should be avoided to allow curing of the adhesive.

#### Adhesion of InterfaceFLOR Modular Carpet

- 1 On the surface of the underlay follow the procedure as outlined in Section 4 for the Set Out using a pencil or waterproof marker.
- 2 Apply Roberts 656, or the equivalent adhesive, to the surface of the underlay using a 1.6mm x 1.6mm “V” notched trowel and allow to dry per manufacturer’s specifications before laying carpet into adhesive. In some conditions an air mover may be required to assist with tack up time.
- 3 Commence installing modular carpet as outlined in Section 8.
- 4 Roll completed installation using a roller no more than 25-30 kgs.
- 5 Finishing should be carried out in accordance with AS/NZS 2455.2 2007 Textile Floor Coverings – Installation Practice Part 2 Carpet Tiles and in line with the Manufacturer’s printed instructions.



NOTE: ADHESIVE SPREAD RATE WILL BE APPROX 5M<sup>2</sup> PER LITRE.

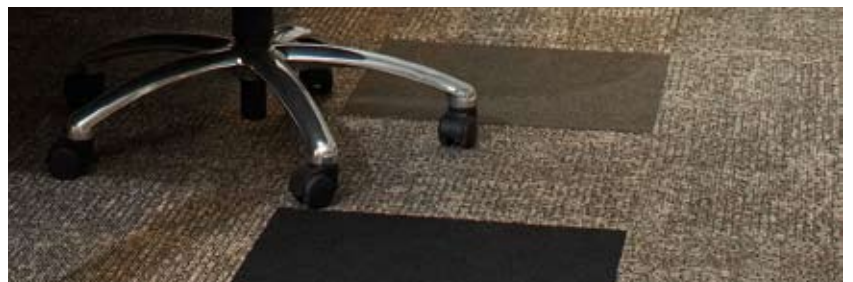

## SYSTEM 6+ 1M X 1M IMPERVIOUS SYSTEM

### INSTALLATION METHODS



NOTES: ANY SEAM SEALER THAT GETS ONTO THE YARN OR TILE FACE SHOULD BE IMMEDIATELY REMOVED.

WHILE STILL WET THE SEAM SEALER CAN BE REMOVED WITH WATER.

WHEN DRY WILL REQUIRE A SOLVENT BASED SEAM SEALER CLEANER.

The installation of 1m x 1m tile to provide a moisture impervious installation can be carried out in the following installation methods:

#### **Intertac**

Utilising Intertac adhesive to hold the tiles in position and seam sealing of the carpet tiles to each other to provide impervious seams.

#### **Freelay**

Freelay of the tile utilising the seam sealer to provide both impervious seams and also to hold the tile in position.

Description of each method as follows -

#### **Option one – Intertac Installation method**

- 1 Apply InterfaceFLOR Floor Sealer as per recommendations.
- 2 Vacuum / sweep the subfloor.
- 3 If InterfaceFLOR Floor Sealer is not being used the subfloor should be primed with an acrylic based floor primer.
- 4 Set out the grid line for the 1m x 1m tile.
- 5 Apply Intertac as per recommendations set out in the InterfaceFLOR Installation Manual.
- 6 Once the Intertac has tacked up install your first tile to the grid line.
- 7 Apply a 3mm bead of seam sealer to the tile edges being careful to only apply seam sealer to the tile backing and not the yarn.
- 8 Install the next tile by sliding the new tile into the already installed tile being careful not to force seam sealer up onto the yarn.
- 9 Follow this procedure for the balance of the area.

**Note:** Any seam sealer that gets onto the yarn or tile face should be immediately removed.

**Note:** While still wet the seam sealer can be removed with water.

**Note:** When dry will require a solvent based seam sealer cleaner.





NOTES: ANY SEAM SEALER THAT GETS ONTO THE YARN OR TILE FACE SHOULD BE IMMEDIATELY REMOVED.

WHILE STILL WET THE SEAM SEALER CAN BE REMOVED WITH WATER.

WHEN DRY WILL REQUIRE A SOLVENT BASED SEAM SEALER CLEANER.

## Option Two – Freelay Installation method

- 1 Apply InterfaceFLOR Floor Sealer as per recommendations.
- 2 Vacuum / sweep the subfloor.
- 3 Set out the grid line for the 1m x 1m tile.
- 4 Install your first tile to the grid line.
- 5 Apply seam sealer to the tile edges being careful to only apply seam sealer to the tile backing and not the yarn.
- 6 Install the next tile by sliding the new tile into the already installed tile being careful not to force seam sealer up onto the yarn.
- 7 Follow this procedure for the balance of the area.

**Note:** Any seam sealer that gets onto the yarn or tile face should be immediately removed.

**Note:** While still wet the seam sealer can be removed with water.

**Note:** When dry will require a solvent based seam sealer cleaner.

## InterfaceFLOR Floor Sealer

InterfaceFLOR Floor Sealer is a water based modified acrylic compound for sealing concrete and other cementitious compounds.

When dry it cures to form an impervious film and displays excellent long term resistance to urine, water, blood and most common chemicals.

It complies with ASTM D 1308-87 for the resistance to urine.

### Floor Sealer Application method

The sealer can be applied to all clean, sound concrete or cementitious substrates.

- 1 Remove all grease or grime with an alkaline cleaner.
- 2 Wash the area and allow to dry for 24 to 48 hours.
- 3 Should the subfloor show signs of laitence (loose surface concrete) this should be removed by shot blasting or similar mechanical means.
- 4 Any previous coatings or curing compounds to be removed as surface must be porous.
- 5 Subfloor and ambient air temperature must be above 10 degrees C.
- 6 Sweep and vacuum all dust from the subfloor.
- 7 Apply one coat of the sealer to the subfloor with roller, spray or brush ensuring that all floor area is covered.  
Covered areas can be easily recognised as the sealer has a light blue tinge.



NOTE: IN AREAS WHERE A FULLY SEALED FLOOR COVERING IS INSTALLED THE USE OF INTERFACEFLOR FLOOR SEALER IS NOT OBLIGATORY.

- 8 Allow first coat of the sealer to dry for 5 hours.
- 9 Apply a second coat of the sealer and allow to dry for 24 hours before application of adhesive.
- 10 If installing 1m x 1m tile without Intertac the installation can commence once the InterfaceFLOR Medical Floor Sealer has touch dried which in most conditions will be 30 to 60 minutes.

**Note:** In areas where a fully sealed floor covering is installed the use of InterfaceFLOR Floor Sealer is not obligatory.

## InterfaceFLOR Seam Sealer

InterfaceFLOR Seam Sealer is a high strength water based seam sealing adhesive designed to provide a moisture impervious seam.

### Seam Sealer Application method

- 1 Installation temperature of working area and substrate is to be a minimum of 10 degrees C and a maximum of 30 degrees C.
- 2 Carpet edges must be clean & dry.
- 3 Starting at one end of the seam apply a 3mm continuous bead to the base of the carpet tile backing ensuring no sealer is on the yarn.
- 4 Slide the next tile into the seam while the seam sealer is still wet ensuring that no seam sealer is forced up onto the yarn.
- 5 Remove any excess wet seam sealer with water on a clean damp cloth.
- 6 Allow seams to fully dry for 24 hours before allowing traffic.

## Seam Sealer Maintenance Requirements

- 1 If spillage on the seam occurs, prevent any traffic on the seam until the spillage has been cleaned and fully dried.
- 2 Do not allow spillage to remain on the seam for more than 48 hours.
- 3 Only water-based cleaners should come into contact with the seam.

## APPENDICES

# 01 CONCRETE SUBFLOOR REQUIREMENTS

## 1 Construction

Concrete subfloor shall be finished off true to grade and in accordance with good building practice and shall be free from rising moisture as per AS2455-1995.

## 2 Surface

### (a) Planeness

When a straight edge 3m long is placed on the surface at any position, no part of the surface is more than 5mm above or below the straight edge.

### (b) Smoothness

When straight edge 150mm long is placed on the surface position, no part of the surface shall be more than 1 mm below the straight edge.

### (c) Finish

New concrete floors shall be steel troweled to a smooth surface but not to a glass finish. They shall be free from score marks, grooves, depressions and scraped free of foreign materials.

## 3 Dryness

Before installation commences, the dryness of subfloor should be determined. For InterfaceFLOR and Heuga modular carpet the moisture content shall not exceed 5.5 per cent, using a moisture unit. If a hydrometer is used, reading should not be greater than 70 per cent at 15 degrees C or above. If the moisture content is above the recommended maximum readings **STOP and DO NOT PROCEED with the installation.** Seek further advice from InterfaceFLOR before proceeding.

## 4 Cleanliness

Before installation begins, foreign materials such as grease, oil, paint, existing floorcovering and any other harmful materials, should be removed. Any surface treatment or old adhesive that will effect the new adhesive or the holding power of the modular carpet should be treated or removed. The floor shall be vacuumed and washed to ensure a perfect bond.

## 5 Porosity

All concrete floors or floors that have been filled using a levelling compound should be sealed using a sealer compatible with the backing system.

## 6 Alkalinity

The subfloor should have an alkalinity level of between pH7 & pH9 to be suitable for carpet installation. Test by wetting the floor with distilled water then using a pH test paper or meter. Should the pH level be outside this range **STOP and DO NOT PROCEED with the installation.** Seek further advice from InterfaceFLOR before proceeding.

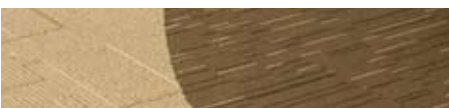

## 02 INTERFACEFLOR INSTALLATION METHODS AND CODES

### DIRECTIONAL Installation – Code DIR

An arrow is printed on the back of each modular tile to indicate pile direction. Make sure the arrows point in the same direction throughout your installation.

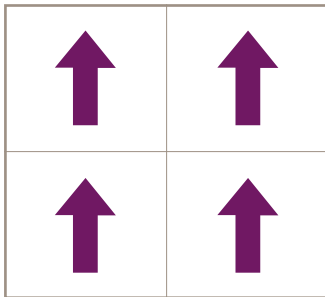

### QUARTER TURN Installation – Code QTR

In this case, the arrows should be turned 90 degrees every other modular tile.

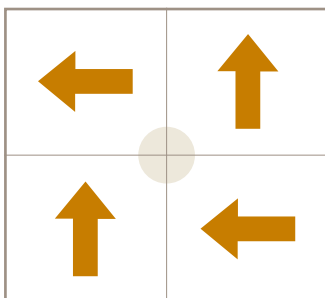

### RANDOM Installation – Code RDM

This pattern allows installation of modular tiles without regard to arrow direction.

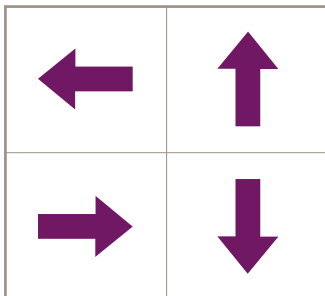

### ASHLAR Installation

This pattern is created by offsetting the side joins of the modular tiles. All arrows should point in the same direction.

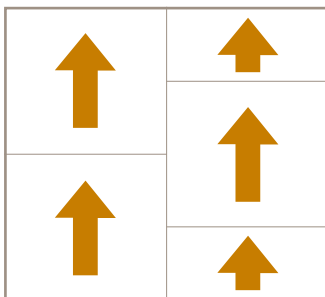

### BRICK Installation

This pattern is created by offsetting the front and back joins of the modular tiles. All arrows should point in the same direction.

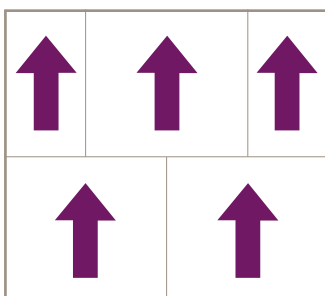

**Code SPEC – Specification Methods** can represent either: **Directional**, **Quarter Turn**, **Ashlar** or **Brick** Installation.

The codes printed on the cartons indicate the manufacturers' recommended installation method. However it is the installers' responsibility to confirm the clients' preferred installation method prior to commencement of installation.



## CONTACTS



### Australia

#### Interface Aust Pty Limited

Phone: 02 8332 2400

Fax: 02 9318 1996

Email: [enquiries.ap@interfaceflor.com](mailto:enquiries.ap@interfaceflor.com)

Web: [www.interfaceflor.com.au](http://www.interfaceflor.com.au)

For urgent installation, cleaning and maintenance enquiries call 1800 785 277

### New Zealand

#### InterfaceNZ Ltd

Phone: 0800 800 656

Email: [enquiries@interfacenz.com](mailto:enquiries@interfacenz.com)

Web: [www.interfacenz.com](http://www.interfacenz.com)

- Interface, InterfaceFLOR, Intersept and GlasBac are registered trademarks of Interface Inc.
- InterTac is a registered trademark of Interface Aust Pty Limited.
- Airstep is a registered trademark of Bridgestone Australia Ltd.
- ™ i2 is a trademark of Interface Aust Pty Limited.