

DAVEY WATER PRODUCTS GUARANTEE FOR AUSTRALIA & NEW ZEALAND

Davey Torrium® control are guaranteed for a period of two years from the date of original purchase to be free of material or manufacturing defects. Should any part fail as a result of such defects within this period, the controller will be repaired free of charge.

TERMS AND CONDITIONS

1. This guarantee applies to all states and territories of Australia and New Zealand only and is subject to the provisions of the Trade Practices Act (Aust.), the Goods and Consumer Protection Legislation of the various Australian states and the Consumers Guarantee Act 1993 (NZ) as applicable.
2. The guarantee period commences on the date of original purchase of the equipment. Evidence of this date of original purchase must be provided when claiming repairs under guarantee. It is recommended you retain all receipts in a safe place.
3. This guarantee covers parts and workshop labour only. Goods should be forwarded, with proof of date of original purchase, to an Authorised Davey Service Centre freight paid.
4. This guarantee is subject to due compliance by the original purchaser with all directions and conditions set out in the Installation and Operating Instructions. Failure to comply with these instructions, damage or breakdown caused by fair wear and tear, negligence, misuse, incorrect installation, chemical or additives in the water, inadequate protection against freezing, rain or other adverse weather conditions, corrosive or abrasive water, lightning or high voltage spikes or through unauthorised persons attempting repairs are not covered under guarantee. The product must only be connected to the voltage shown on the nameplate.
5. Without limiting the original purchaser's entitlements under the Trade Practices Act (Aust.), the Goods & Consumer Protection Legislation of the various Australian states, or the Consumers Guarantee Act 1993 (NZ), Davey shall not be liable for any loss of profits or any consequential, indirect or special loss, damage or injury of any kind whatsoever arising directly or indirectly from the product or any defect.
6. Where the Trade Practices Act (Aust.), the Goods and Consumer Protection Legislation of the various Australian states and the Consumers Guarantee Act 1993 (NZ) does not apply, Davey shall not be liable for any loss of profits or any consequential, indirect or special loss, damage or injury of any kind whatsoever suffered by the purchaser arising directly or indirectly from the product or any defect and the purchaser shall indemnify Davey against any claim by any other person whatsoever in respect of any such loss, damage or injury.
7. Nothing in this guarantee is intended to have the effect of contracting out of the provisions of the Trade Practices Act (Aust.), the Goods and Consumer Protection Legislation of the various Australian states and Consumers Guarantee Act 1993 (NZ) except to the extent permitted by the various Acts and this guarantee is to be modified to the extent necessary to give effect to that intention.
8. Davey may be collecting personal information from you in order to provide you with a service. Davey Water Products Pty Ltd promises only to use this information in accordance with the Provisions of the Privacy Act 1988 (Cth) and the Privacy Policy of Davey Water Products Pty Ltd which is available at davey.com.au.

® Davey and Torrium are registered trademarks of Davey Water Products Pty Ltd.

© Davey Water Products Pty Ltd 1999

Davey Water Products Pty Ltd

Member of the GUD Group

ABN 18 066 327 517

Head Office and Manufacturing

6 Lakeview Drive,
Scoresby, Australia 3179
Ph: +61 3 9730 9222
Fax: +61 3 9753 4100
Website: davey.com.au

Customer Service Centre

Ph: 1300 367 866
Fax: 1300 369 119
E-mail: sales@davey.com.au

Interstate Offices

Sydney • Brisbane • Adelaide
Perth • Townsville

International

6 Lakeview Drive,
Scoresby, Australia 3179
Ph: +61 3 9730 9121
Fax: +61 3 9753 4248
E-mail: export@davey.com.au

Germany

Kantstrasse 53, 04275 Leipzig
Ph: +49 341 301 0412
Fax: +49 341 301 0413
E-mail: akrenz@daveyeurope.com

USA - Davey Pumps Inc.

Ph: +1 630 898 6976
Fax: +1 630 851 7744
Website: daveyusa.com
E-mail: sales@daveyusa.com

Davey Water Products - New Zealand

7 Rockridge Avenue,
Penrose, Auckland 1061
Ph: +64 9 570 9135
Fax: +64 9 527 7654
Website: daveynz.co.nz
E-mail: sales@daveynz.co.nz

Davey Spa - New Zealand

2 Rothwell Avenue,
North Harbour, Auckland 0632
Ph: +64 9 415 8622
Fax: +64 9 415 8621
Website: spa-quip.co.nz
E-mail: service@spa-quip.co.nz

DEPEND ON
DAVEY

WATER PRODUCTS

Installation and Operating Instructions

DAVEY Torrium Pressure System Controller



WARNING : The Torrium® controller, pump and associated pipework operate under pressure. Under no circumstances should the Torrium® controller, pump or associated pipework be disassembled unless the internal pressure of the unit has been relieved. Failure to observe this warning will expose persons to the possibility of personal injury and may also result in damage to the pump, pipework or other property.



Please pass these instructions on to the operator of this equipment.

Congratulations on your purchase of a high quality, Australian built Davey Torrium® controller. All components have been designed and manufactured to give trouble free, reliable operation.

Your Torrium® controller is an electronic flow control device – a Davey designed product that enables the use of a highly efficient pump design and offers the following benefits:–

1. Enables the pump to deliver a constant flow of water particularly at low flow rates – reducing the inconvenience of pressure variation in showers etc.
2. Provides automatic “cut-out” protection should the pump run out of water or overheat*, should the pump fail to start due to low voltage or a blockage in the pump.
3. Provides warning indications for critical and noncritical system faults.
4. Has adaptive pressure cut-in which allows the pump to start at approximately 80% of the maximum pressure at last shut-down. This allows the controller to accommodate varying inlet pressures and pump performance.
5. Automatic retry functions in the event of a critical system fault.

* Motor overload / overheat protection not included. Motor must have its own overload / overheat protection.

Before installing your Torrium controller, please read all instructions carefully as failures caused by incorrect installation or operation are not covered by the guarantee. Your Torrium controller is designed to handle clean water. The system should not be used for any other purpose without specific referral to Davey. The use of the system to pump flammable, corrosive and other materials of a hazardous nature is specifically excluded.



WARNING: Some insects, such as small ants, find electrical devices attractive for various reasons. If your pump enclosure is susceptible to insect infestation you should implement a suitable pest control plan.

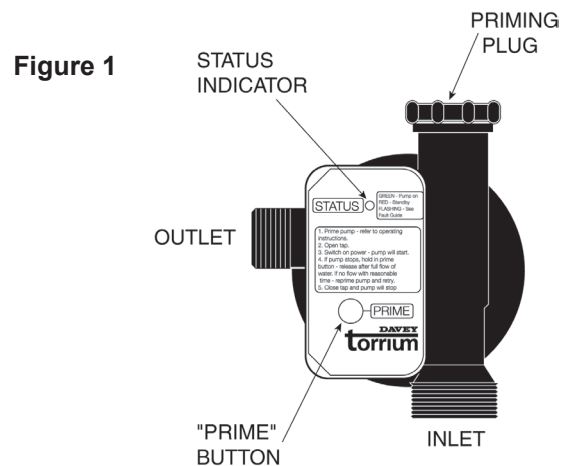

Selection

The Torrium® controller is available in different versions to suit different Davey single phase pump models. Please ensure you have the right unit for the Davey Pump model (see table below).

Torrium® Model	Davey Model to Suit
T45	XP350H, XP500H, XP700H, XP900H, HS50-05, HS60-06, Aquamate, XF92, XF192, XJUltra, X50, XJ90, X90, M2031, M2041, M4031, M4041, M8031 & 6210
T70	HS50-06, HS60-08, XJ70, X70, M2051, M2061, M4051, M4061, M8041, 95S1, 125S1*, 165S1*, 95D1, 125D1 & 165D1

*Note: Higher pressure supercell tank may be required for 22695 and 22699 injector options.



NOTE: The above table assumes the pump is installed with a small flooded suction, or a normal suction lift. High incoming pressures may require a different installation procedure - consult your Davey dealer for assistance.

Fitment of the Torrium® controller

The Torrium® controller fits onto the outlet of the pump.

The Torrium® controller is designed to fit in place of a Davey Hydrascan®, or can be installed to replace another form of controller eg. pressure switch.

Davey Pump Model	Connection Method Recommended
XP350H, XP500H, XP700H, XP900H, plus these models where they are already fitted with a Davey Hydrascan® controller: HS50-05, HS60-06, HS50-06, HS60-08, M3031, M3041, M6031, M6041, M8031, M8041, M3051, M3061, M6051, M6061, M8041	Fits straight onto the Davey connection flange fitted to these models
XP350P, XP350P3C, XP350P8C, Aquamate & Jet Plus models	Remove any outlet tees and replace with Davey Adaptor kit P/No 31492 or P/N 32320
HS50-05, HS60-06, HS50-06, HS60-08, XF92, XF192, M3031, M3041, M6031, M6041, M3051, M3061, M6051, M6061	Remove any outlet tees and replace with Davey Adaptor kit P/No 31612
XJUltra, X50, XJ70, X70, XJ90, X90, M8031, M8041, 95S, 125S, 165S, 95D, 125D, 165D & 6210	Remove the outlet tee. Fit a P/No 13551 to XJ models or a nipple to provide a 1" BSPM thread on the outlet. Fit Davey adaptor kit P/No 31492 to nipple. Block off any other pump outlet. Fit Torrium® controller to adaptor flange. Fit top mounted tank where applicable to top of Torrium® controller if you wish (not compulsory).

Fitting the 32320 Rotary Coupling

This coupling allows the pump controller to be fitted simply and easily to the pump discharge on models with 1" female outlets.

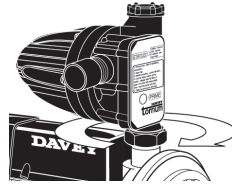

For Davey models the coupling has an oring seal. If used on other brands, thread tape will be required. The controller adaptor nut is able to rotate independent of the pump adaptor nipple and thus the complete pump, this allows it to be tightened onto the pump controller inlet. – see illustration below. Hand tighten only the controller adaptor nut to ensure a firm connection to your controller. The oring on the base of the controller will ensure a leak-proof seal between the rotary coupling and the controller.

The ability to rotate the adaptor nut also means that the complete controller, once fitted to the rotary coupling, can be rotated a full 360° in the horizontal plane, without causing the coupling to unscrew from the pump outlet.

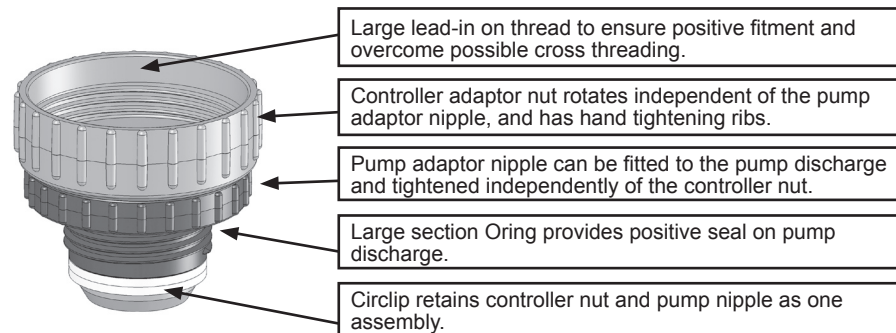

Fitting the 31492 adaptor flange (1" male pump outlet)

First, fit the Torrium® controller connection nut over the pump outlet with the internal thread upwards. Wrap the pump outlet or nipple with thread tape. Next, screw the Davey controller connection flange onto the pump outlet or nipple as applicable. Firmly hand tighten the connection flange. **DO NOT OVERTIGHTEN!**

Position the control unit on top of the pump and tighten the connection nut. The control unit is capable of 360° rotation to enable the most convenient positioning of the discharge piping. Loosening the connection nut enables convenient adjustment.

 During servicing, use only approved, non-petrochemical based oring and gasket lubrication. If unsure, consult your Davey Dealer for advice.

 **WARNING:** Do not use hydrocarbon based or hydrocarbon propelled sprays around the electrical components of this controller.

After Sales Service

For professional after sales service or repair contact your Davey Dealer. For assistance in locating your nearest dealer contact the Davey Customer Centre on 1300 367 866

 **Only connect the discharge pipework to the discharge port. The priming port is not a discharge port.**

h) PUMP HAS OPERATED NORMALLY FOR SOME TIME, BUT NOW WILL NOT RESTART OR THE PRESSURE DROPS TO A LOWER POINT BEFORE THE PUMP STARTS – STATUS INDICATOR LIGHT IS ILLUMINATED WITH THREE FLASHES PER SEQUENCE

1. Your Torrium® has detected a slow leak and has dropped the cut-in pressure to a lower cut-in pressure to help reduce the pump cycling. Correct the leak, and your Torrium® will return to normal operation automatically or cycle power for immediate return to normal.



NOTE: The Torrium® controller is adaptive. If your pump draws air or is subject to blockage, the Torrium® adapts to its new maximum pressure. This may result in your system pressure not dropping below the new cut-in pressure and your pump not starting. Should this occur, re-prime your pump unit. Should this not prove successful, it is likely you have a blockage in the pump. You should contact your Davey dealer for assistance.

i) PUMP HAS STOPPED OPERATING – STATUS INDICATOR LIGHT IS ILLUMINATED RED FLASHING THREE TIMES PER SEQUENCE.

1. Your Torrium® has detected high water temperature in the pump. Once the water has cooled the Torrium® will automatically restart the pump.

j) PUMP IS OPERATING NORMALLY, BUT THE STATUS INDICATOR LIGHT IS ILLUMINATED FLASHING TWICE PER SEQUENCES – RED FLASHES WHILE IN STANDBY OR AMBER FLASHES WITH CONSTANT GREEN WHILE PUMP RUNNING

1. Your Torrium® has detected low voltage (below 180 volts for >10 seconds). The low voltage may result in a small pump performance shortfall. Once the voltage has returned to normal the status indicator will return to normal.



NOTE:

- a) For protection, Davey® pump motors are fitted with an automatic “over temperature” cut-out. Constant tripping of this overload device indicates a problem e.g. low voltage at pump, excessive ambient temperature (above 50°C) in pump enclosure.
- b) The Torrium® control device may have to be reset after rectifying any of the above operating troubles. This is done by pushing in the “prime” button and releasing it after 2 seconds, or switching the power supply off then on.



WARNING: When servicing or attending pump, always ensure power is switched off and lead unplugged. Electrical connections should be serviced only by qualified persons. If the electrical supply lead of this controller is damaged, the unit must be replaced.



Care should also be taken when servicing or disassembling pump to avoid possible injury from pressurised water. Unplug pump, relieve pressure by opening a tap on the discharge side of the pump and allow any hot water in the pump to cool before attempting to dismantle.

Extra Draw-off Capacity

The Torrium® controller has an in-built accumulator which will accommodate small leaks. In some applications it may be appropriate to install additional accumulator (Supercell pressure tank) capacity. These applications includes:

- Long suction lines (see Suction Lines / Lift)
- Low flow appliances connected to the pump, such as evaporative air conditioners, slow filling toilet cisterns.

Any additional accumulators can be installed either in place of the priming plug (see Figure 1) for tanks up to 20 litres total capacity, or for larger tanks, downstream of the controller (ie. between the controller and the first outlet).

Where extra draw-off capacity is utilised the additional pressure tank should have a pre-charge of 70% of the maximum system (shut-off) pressure, see table below.

Evaporative coolers and extra draw-off capacity

Where a Torrium® equipped pump is required to supply water to an evaporative cooler, the Torrium® will detect the repetitive and limited demand. This will result in the Torrium® activating it’s “slow leak” mode, whereby the pump start pressure is set at 50% of the maximum pressure at last shut-down. To provide the maximum draw-off from the additional pressure tank, the tank’s pre-charge should be set at 45% of the pump shut-off pressure.

Davey Pump Model	Tank Precharge
XP500H, XP700H, XP900H, Aquamate, XF92, XF192 & 6210	210 kPa
XP350H, HS50-05, HS60-06	250 KPa
XJUltra, X50m XJ90, X90, M3041, M6041 & M8031	320 kPa
M3051, M6051, M8051, HS50-06, HS60-08, XJ70, X70	350 kPa
95S1 with 22690 jet kit, 125S1 with 22693 jet kit, 165S with 22697 jet kit	435 kPa
95S1 with 22691 jet kit, 125S1 with 22694 jet kit, 165S with 22698 jet kit, 95D1 & 125D1	440 kPa
125S with 2265, 165S with 22699, M2061 & M4061	480 kPa

Fit the Supercell pressure tank (up to 20 litres total capacity) to the tank connection/priming port **with thread tape**. Firmly **hand** tighten.

! DO NOT USE THREAD SEALING COMPOUNDS, HEMP OR PIPE DOPE!

Suction Lines / Lift

The Torrium® controller has an in-built non-return (check) valve fitted. In flooded suction installations there is no need to have a suction non-return valve.

Installations with flooded suction require a gate or isolating valve so water supply can be turned off for pump removal and servicing.

In suction lift installations a footvalve will normally be required for the pump to retain prime.

In some suction lift installations there may be good reason to remove the inbuilt check valve to ensure that the discharge pressure is also applied to the suction line and footvalve. This could be where the suction line was very long or where there was concern regarding a leaking footvalve. This may not always be applicable and it is acceptable to retain the inbuilt check valve in the Torrium on suction lifts with good suction plumbing.

Should the inbuilt check valve be removed though, an additional accumulator should be fitted to the Torrium, or discharge pipework as applicable, to ensure the pump is not cycled on shut down. The size of this accumulator will depend on the size, length and type of pipe used on the suction.

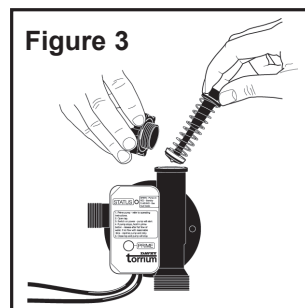
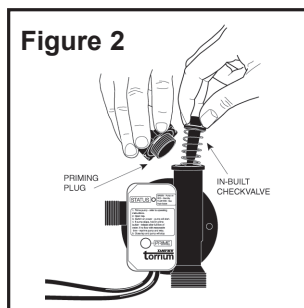

! Abrasive Materials - The pumping of abrasive materials will cause damage to the pressure system which will then not be covered by the guarantee.

Pipe Connections

For best performance use P.V.C. or polythene pipe at least the same diameter as the Torrium® controller outlet.

Larger diameter pipe may be used to minimise resistance to flow when pumping longer distances.

Flexible pipe will help alignment during installation, as well as reduce noise transfer during operation.

Trouble Shooting Check List

- a) **PUMP HAS STOPPED OR MOTOR RUNS FOR SHORT PERIOD ONLY WHEN SWITCHED ON OR PRIME BUTTON PUSHED, BUT DOES NOT PUMP - STATUS INDICATOR LIGHT ILLUMINATED RED FLASHING ONCE PER SEQUENCE**
 1. Suction line and pump body not filled with water.
 2. Air leaks in suction lines or suction pipe not under water.
 3. Air trapped in suction lines (also possible with flooded suction due to uneven rise in piping; eliminate humps and hollows).
 4. No water at source or water level too low.
 5. Valve on suction lines closed. Open valve & pump will restart automatically or press "Prime" button.

- b) **PUMP SWITCHES ON AND OFF FREQUENTLY (CYCLING)**
 1. Cycling may occasionally be caused by float valves filling tanks - see "Cistern Fill Mode".
 2. Leaking taps, float valves etc. check plumbing.
 3. Leaking check valve/foot valve.
 4. Discharge plumbing has been connected to the priming port.

- c) **MOTOR DOESN'T START WHEN SWITCHED ON - LOW PRESSURE INDICATOR LIGHT NOT ILLUMINATED**
 1. Power not connected or no power available from supply outlet.

- d) **MOTOR STOPS - STATUS INDICATOR LIGHT IS ILLUMINATED RED, FLASHING TWICE PER SEQUENCE**
 1. Motor "over temperature" cut-out tripped. Consult Davey dealer.
 2. Motor not free to turn - e.g. a jammed impeller. Consult Davey dealer.
 3. Prime button has been held in for too long. Release prime button and switch off power for 1 minute to allow unit to reset.

- e) **PUMP WILL NOT STOP**
 1. Water leaks on discharge side of pump.

- f) **PUMP WILL OPERATE NORMALLY INITIALLY BUT WILL NOT RESTART ON WATER DEMAND - STATUS INDICATOR LIGHT NOT ILLUMINATED**
 1. Power supply problem - see c) 1.

- g) **PUMP WILL OPERATE NORMALLY INITIALLY BUT WILL NOT RESTART ON WATER DEMAND - STATUS INDICATOR LIGHT IS ILLUMINATED RED CONSTANT**
 1. Suction air leak - pump has partially lost prime.
 2. Blocked impellers or suction.
 3. Discharge valve closed - open valve.

 **WARNING:** Automatic reset thermal overloads may allow the pump to restart without warning. Always disconnect the pump motor from the electrical supply before maintenance or repairs.

 **WARNING:** When servicing or attending pump and/or controllers, always ensure power is switched off and lead unplugged. Electrical connections should be serviced only by qualified persons.

 Care should also be taken when servicing or disassembling pump to avoid possible injury from hot pressurised water. Unplug pump, relieve pressure by opening a tap on the discharge side of the pump and allow any hot water in the pump to cool before attempting to dismantle.

 **IMPORTANT:** DO NOT USE petroleum based fluids or solvents (e.g. Oils, Kerosene, Turpentine, Thinners, etc) on the plastic pump components or seal components.

 **WARNING:** Do not use hydrocarbon based or hydrocarbon propelled sprays around the electrical components of this controller.

Maintenance

 **WARNING :** Under no circumstances should Torrium® controller be disassembled. Failure to observe this warning will expose persons to the possibility of personal injury and may also result in damage to other property. Do not dismantle, no user serviceable parts, spring under pressure.

The only regular attention your new pressure system requires is to check any supplementary pressure tank's air charge every 6 months. This can be checked at the air valve with a tyre gauge. Do not charge tank to a higher pressure than 70% of the maximum system pressure.

To check air pressure in tank:

1. Switch off pump.
2. Open outlet nearest to pump to release water pressure.
3. Charge tank to desired setting using air pump and check with tyre gauge.
4. Switch on.
5. Close outlet.

***NOTE:**

- a) For protection, Davey® pump motors are fitted with an automatic "over temperature" cut-out. Constant tripping of this overload device indicates a problem e.g. low voltage at pump, excessive temperature (above 50°C) in pump enclosure.
- b) The Torrium® controller may have to be reset after rectifying any of the above operating troubles. This is done by pushing in the "Prime" button and releasing it after 2 seconds.

 **During servicing, use only approved, non-petrochemical based oring and gasket lubrication. If unsure, consult your Davey Dealer for advice.**

Priming your System

You can prime your system via the priming plug, but you may need to:-

1. Remove the in-built check valve (see figures two and three) to allow the water to enter the pump - don't forget to replace it.
2. Allow for specific priming instructions associated with various pump models - read the Installation & Operating Instructions for your specific pump model.

Power Connection

 In accordance with AS 3350.2.41 we are obliged to inform you that this pump is not to be used by children or infirm persons and must not be used as a toy by children.

 The Davey Torrium® controller has a status indicator light mounted on its front panel. This light will be illuminated to indicate various operating conditions and system faults. The light will only work when the unit is connected to the correct electrical supply.

 Connect lead to power supply designated on pump/controller label, do not use long extension leads as they cause substantial voltage drop, poor pump performance and may cause motor overload.

 The electrical connections and checks must be made by a qualified electrician and comply with applicable local standards.

The Torrium® controller has three terminations for connection to the pump motor, an Active, a Neutral and an Earth connection.

The Earth connection must be made first.

The colour codes for the terminations are as below:

Voltage	Active	Neutral	Earth
220-240V 50/60Hz	Brown	Blue	Green / Yellow
110-115V 60Hz	Black	White	Green

Where you are replacing an existing Davey Hydrascan®, Davey Presscontrol or Davey pressure switch, the connections should be identical for the Torrium® controller. See the underside of the capacitor cover for a wiring diagram.

The exception to this rule is where the special four wire Hydrascan® fitted to the M series models is to be replaced. In such a case consult your Davey Dealer for assistance.

Where the Davey pump involved has not had a controller fitted before, use the wiring details below as a guide.

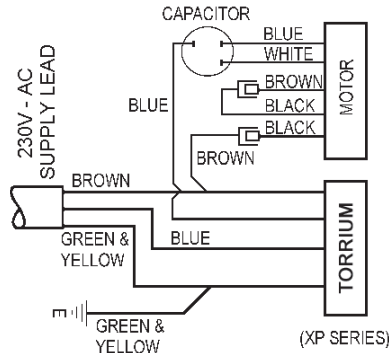

NOTE: Where Davey “Plug & Play” connectors are available on the pump and the Torrium® controller refer to the Installation & Operating Instructions for the pump regarding correct connection procedure.

Status Indicator

The Torrium® has a status indicator light on the front panel. This light will enable you to understand what your pump is doing.

Condition	Indicator readout	Pump operation	Restart / Reset Method
Standby mode	Red light	Standby	Pressure drop
Cistern fill	Yellow/Amber light	Running - 2 minutes minimum run time	Auto, push “Prime” button or cycle power off / on
Running	Green light	Running	N/A
Loss of Prime	Red light single flash	Stops, auto-retry & “water return” activated	Push “Prime” button or cycle power off / on
Locked rotor or ‘Prime’ button held in too long	Red light double flash	Stops	See Trouble shooting guide
Undervoltage	Red light double flash	Normal operation	Wait till voltage >180 volts or push “Prime” button or cycle power off / on
Water over temperature	Red light triple flash	Stops	Wait till water temp < 60°C
Slow leak	Red light triple flash	Normal operation with reduced cut-in pressure	Auto-reset or push “Prime” button or cycle power off / on

Both the Red & Green Indicators are shown in the same window. It is possible for the pump to be running (ie. Green indicator) and for a Red flash sequence to happen at the same time. In that case the Red flash will show as a Yellow or Amber flash.

NOTE: Only one fault condition will be indicated at once.

Cistern Fill Mode

When your new Torrium® is used on a pressure system which is used to fill toilet cisterns or troughs, a special feature of the Torrium® controller may be activated. This special feature is activated when the controller detects three quick stop start sequences in a short period. When activated the status indicator will glow “Amber”, and the pump will run on for two minutes. This allows the cistern to be filled with the minimum of pump cycles.

Auto-retry and Water Return Modes

Should your Torrium® detect a loss of prime, after stopping the pump, it will wait five minutes before activating Auto-retry and Water Return modes. Auto-retry automatically starts the pump to see if the pump is now primed. It does this after 5 mins, 30 mins, 1 hr, 2 hrs, 8 hrs, 16 hrs and 32 hrs. Water return mode will restart the pump automatically if the Torrium® detects water flow through it.

NOTE: If multiple errors are present, the highest priority error (least number of flashes) is indicated. Any previous fault code is lost until it recurs.

Electrical Power Surge Protection

An electrical power surge or spike can travel on the supply lines and cause serious damage to your electrical equipment. The Torrium® controller has a metal oxide varistor (MOV) fitted to help protect it’s circuit. The MOV is not a lightning arrestor and may not protect the Torrium® controller if lightning or a very powerful surge hits the pump unit.

If the installation is subject to electrical power surges or lightning we strongly recommend the use of a suitable surge protection device on ALL electrical equipment.

In accordance with AS 3350.2.41 we are obliged to inform you that this device is not to be used by children or infirm persons and must not be used as a toy by children.

WARNING: Abrasive Materials
The pumping of abrasive materials will cause damage to the Torrium® controller which will then not be covered by the guarantee.

NOTE: For protection, the Davey pump motors are fitted with an automatic reset thermal overload, constant tripping of this overload indicates a problem e.g. low voltage at pump, excessive temperature (above 50°C) in pump enclosure.