



**WATER SOFTENER
WITH MICROPROCESSOR
INSTALLATION & OPERATING
INSTRUCTIONS**

Model : AS0922MP-CL
Serial No :

Manufacturer and Supplier of



FILTRATION & WATER TREATMENT PRODUCTS
for commercial, industrial and residential application



Telephone: (07) 3219 2233
Email: sales@ibcwater.com.au

Facsimile: (07) 3219 2266
Website: www.ibcwater.com.au

GENERAL WATER SOFTENER PERFORMANCE DATA SHEET

Automatic Model No.	Capacity & Salt Dosage		Recommended Maximum Service Flow Rate	Pipe Size		Resin Volume	Approx. Shipping Weight (kg)	Space Required
	Minimum	Maximum		Inlet Outlet	Drain			
	gram/kg	gram/kg	Cont. / Peak Flow LPM	mm	mm	Litres	Per Kg	metres
AS0922MP-CL	770/1.4	1540/5.3	16 / 22	25 BSP-F	12	22	33	0.70 0.50 1.20

BRINE CHAMBER:

POLY MOULDED

System Operating Pressure: 330- 690 kPa

Temperature: 4° x 43°C

Electrical: 240V—16VAC 50Hz 3 watts maximum

Control Valve: Series WS1-E1 with bypass valve and installation fittings.

WARNING

A pressure reduction valve must be installed in areas of high water pressure (above 690kPa)

A water hammer arrestor must be installed if water hammer prevails, between the softener and the closing off device.

Caution: Do not use where water is microbiologically unsafe or with water of unknown quality.

FAILURE TO OBSERVE WARNINGS WILL VOID WARRANTY

BASIC INSTALLATION OF IBC CABINET WATER SOFTENER SYSTEM

FITTED WITH MODEL WS1 VALVE/EI CONTROL

Check the equipment upon arrival for damage or shortages and report same to our Office or Agent before starting.

Position the Softener on a firm foundation, preferably concrete, with sufficient space for operation and maintenance. The softener must be within One and a Half metres of a 240V-10 amp Power Outlet. The softener **MUST** be installed under cover and protected from the weather as the Valve control and Transformer are not waterproof.

- STEP 1 The Softener is supplied with the resin preloaded in the tank and the valve/ bypass assembled on the tank.
- STEP 2 Connect the Inlet and Outlet pipes and Drain line to the control valve as per the instruction book installation details. **Note the directional arrows on the Valve. The inlet is on the right hand side facing the front of the valve.** The drain is from the larger elbow on the top of the valve. The valve Inlet and Outlet threads are 25mm BSP Female with a 12mm push on Hose connection for the drain line.
- STEP 3 Remove front lid from the cabinet. Then connect cabinet brine overflow drain line to waste trap.
- STEP 4 Load 2 bags of 25kg high purity water softener salt into the brine tank and replace lid.
- STEP 5 Refer to Instruction booklet for start up procedure (placing conditioner into Service")

NOTE: The **INLET PIPE** connection is on the right hand side as viewed from the front of the valve.

NOTE: The **POWER** connection transformer socket is on the right hand side as viewed from the front of the valve at the back of the control.

Table 3

MODEL	RESIN LITRES	BRINE TANK - SALT LOADING KG
AS0922MP-CL	22	50

WS1-MP VALVE



Top Strainer

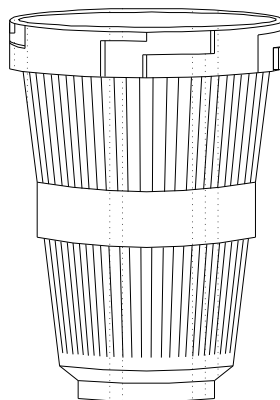

Note Never Shorten the Riser Pipe installed inside the tank.

WATER HARDNESS TEST METHOD

1. Water to be tested should be taken from a tap after the water softener
2. Measure 10ml of water into plastic bottle supplied (approximately 1/3 full)
3. Add one Yes/No tablet to sample water, replace cap and shake until tablet has completely dissolved.
(NOTE: do not handle Yes/No tablet with fingers)
4. The final colour to be obtained for soft water is green. (Note: The shade of green may vary.) If the colour turns red, the water is above 20 mg/l hardness, therefore another regeneration is recommended. **However if the raw water is very high in hardness it may not be possible to achieve a reduction in hardness below 20mg/l but the softener is still working correctly. Consult IBC Water for further clarification.**
- 5.
6. Rinse plastic bottle after each test has been completed.
7. When used as above, the tablets change the colour from green to red at a hardness of approximately 20ppm based on a sample volume of 10mls.

Other hardness test kits are available for more accurate testing eg.

Hardness Tablets

Directions: Take a 50ml sample of water in a screw capped bottle. Add one (1) tablet to sample, shake or crush to disintegrate. Repeat until last trace of reddish tinge disappears. The final colour is usually blue but with some water a greyish coloured end point is obtained.

Using 50ml sample -
Hardness ppm = (number of tablets x 40) - 20

LR (BW) Tablets

Directions: Take a 100ml sample of water in a screw capped bottle. Add one (1) tablet to sample, shake or crush to disintegrate. Repeat until last trace of reddish tinge disappears. The final colour is usually blue but with some water a greyish coloured end point is obtained.

Using 100ml sample -
Hardness ppm = (number tablets x 2) – 1

Contact IBC Water if further details are required.

MODEL AS0922MP-CL SOFTENER

THE MICROPROCESSOR CONTROL WILL REQUIRE BASIC DATA PROGRAMMING TO SUIT THE RAW WATER HARDNESS AND DESIRED UNIT CAPACITY

IMPORTANT: IT IS ESSENTIAL THAT YOU READ THE GENERAL CONDITIONER INFORMATION AND CONTROL SETTINGS OF THIS MANUAL BEFORE ATTEMPTING TO SET THE FUNCTIONS OF THIS UNIT. THE DEALER OR AGENT CAN SUPPLY THE RAW WATER HARDNESS. **HOWEVER DO NOT EXCEED THE MAXIMUM THROUGH PUT IN CUBIC METERS BASED ON THE ACTUAL RAW WATER HARDNESS FIGURE IN TABLE 2.**

SUGGESTED SETTINGS

(VOLUME THROUGHPUT IN CUBIC METRES Based on Maximum Exchange Capacity)

TABLE 2

Raw Water Hardness mg/L CaCO ₃	Maximum Program Setting In Cubic Metres throughput (see note)
60	25.5
80	19.0
100	15.0
120	12.5
140	11.0
160	9.5
180	8.5
200	7.5
250	6.0

Important Note:

To provide uninterrupted soft water supply to the end of the service and just before a regeneration is due it is strongly recommended to de-rate the throughput setting by the average daily usage. Eg. If the setting is elected at 15.0 then deduct a figure of one days usage. (Note: Estimated daily consumption per person is 300 litres.or 0.3Cubic Metres) :- for 3 people =0.9cubic metres :- Deduct One Cubic Metre.

For Commercial applications it will be necessary to determine the daily water usage figure.

For other raw water hardness multiply the throughput at 100 hard i.e.15.0 by the ratio of 100 divided by the desired hardness.

e.g. for 50 hard = $15.0 \times \frac{100}{50}$ = 30.00

e.g. for 170 hard = $15.0 \times \frac{100}{170}$ = 8.8 input 8.5

Note: The program for M³ input will only accept the inputting of a whole or half a number. e.g. If the calculated throughput is say 9.75m³ then what can be programmed in is 9.5 or 10.0. However, always select the lower figure i.e. 9.5 in this example. Above 50M³ the program will only accept increments in 2.5 , therefore only input a lower figure eg. Calculation gives 58.33 therefore input 57.5.

Note :- The chart is based on low to medium total dissolved solids water ,consult IBC Water for using the softener for waters above 250 mg/L hardness.

Programming Parameters to be input at commissioning:

1. Throughput in cubic metres from Table 2.
2. Current time of day.

NOTE: All other parameters have been factory pre-set – DO NOT CHANGE.

CUSTOMER/ INSTALLER PROGRAMING INSTRUCTIONS

The WS1-E1 has been factory programmed with the majority of the commands and parameters installed. It is necessary on commissioning of the softener to program in the **M³ throughput** and if desired another **time of day** when regeneration is to proceed or accept the **factory default of 2am** and to set up the clock to register the current time of day. The transformer plugs into the socket mounted on the back face of the front panel of the valve

The procedure is as follows :

Plug in the transformer into the mains and turn on – valve will sequence to the service position.

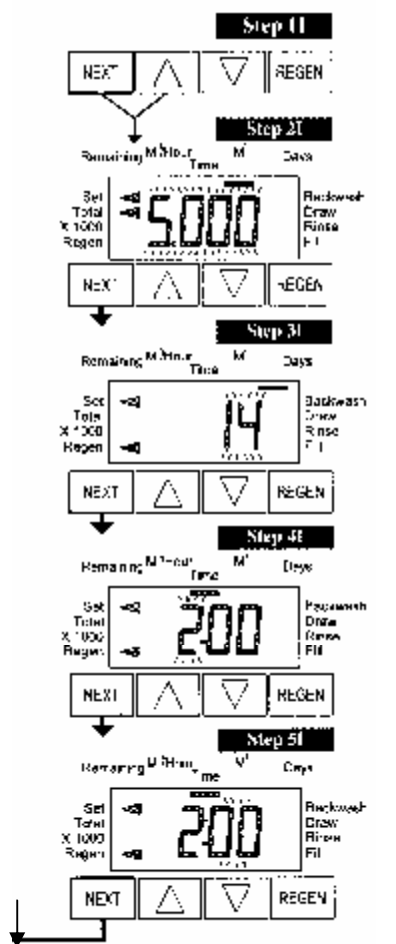

Exit back to display screen which would normally show 'remaining M³'. Note: When in the program mode. Step 1 to 5. If it is desired to go back one program step press 'regen' button to return back.

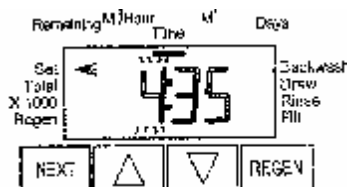

Step 1I – To enter installer display press the **NEXT** and **▲** buttons simultaneously for 5 seconds and release. Display flashes.

Step 2I – Using the **▼▲** keys input desired **volumetric throughput** capacity (table 2) in cubic meters (Adjustable from 0.5 - 250.0). It is suggested the value entered be equal to the actual volumetric capacity minus a 1 day's estimated water usage. Press **NEXT** to go to Step 3I

Step 3I – Use **▼** or **▲** buttons to Set to "OFF" . Press **NEXT** to go to Step 4I.

Step 4I – Use **▼** or **▲** buttons to set the time of regen 'hour'. Press **NEXT** to go to Step 5I. If the factory default of 2am is to be changed.

Step 5I – Use **▼** or **▲** buttons to set the time of regen 'minutes'. Press **NEXT** to exit installer display.

Setting Current Time of Day

Push **NEXT** button until **TIME** of day screen is displayed ie bar appears under **TIME** function . Press and hold the **▼** OR **▲** arrow until a arrow appears against **SET** and **release** the button and the hour display flashes and then set the correct hour. Then press the **NEXT** button. The minutes will flash. Press the **▼** OR **▲** arrow until the correct minutes is displayed. Note only press **one** **▲**OR **▼** button NOT both together.

Press the **NEXT** button to return to the display screens. If the **NEXT** button is not pressed hours or minutes will flash for five minutes before returning to display screen.

Then using the **NEXT** button select which screen you wished displayed. Recommended to leave on **'remaining-M³'**.

Power outage

When electric power is interrupted the microprocessor will hold all relevant information in memory except for the current time of day.

Current time of day

When power is restored the display will show zeros and will again register when the current time of day is reset. If power is lost during a regeneration cycle the valve will remain operational in the current cycle and will recommence electrically in that cycle when power is restored.

In long power outages it is advisable to check that the system is not in a regeneration cycle that could be discharging water to drain and in this instance it would be advisable to place the valve in bypass mode until power is restored.

General

Note: When changing valve operational cycles the valve control will emit a number of whirring sounds.

Note :- The valve cannot be positioned into the regeneration mode without ELECTRIC Power.

Note:- It is very important that on commissioning the tank and valve be completely vented of air .

**MODEL AS0922MP WATER SOFTENER
WITH CONTROL VALVE SERIES MODEL WS1EI**

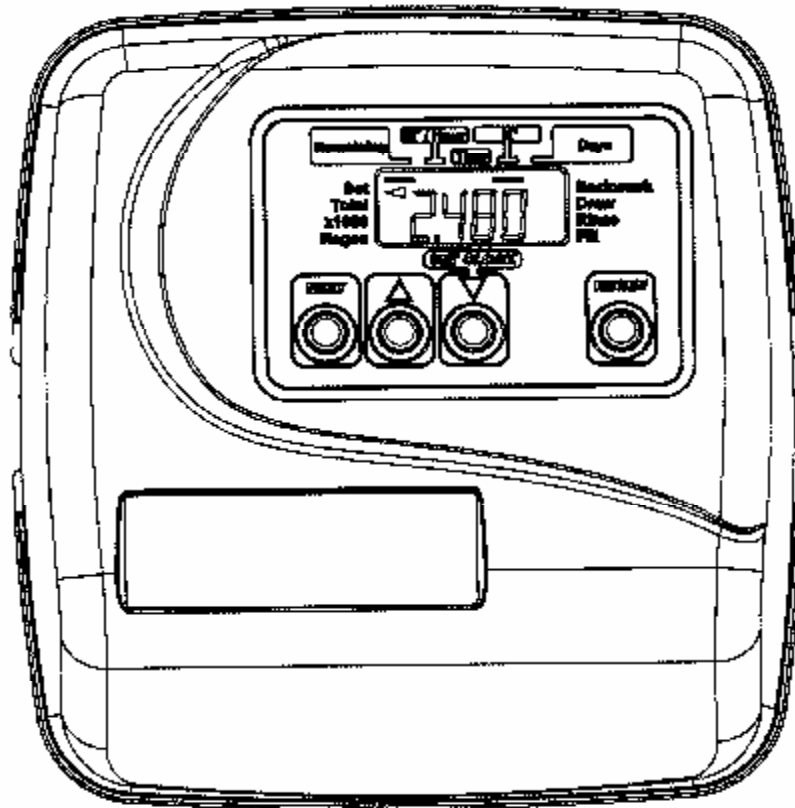

GENERAL WS1 CONTROL VALVE SPECIFICATONS

Inlet/Outlet Fittings	25mm BSP "F" PVC elbows	
Cycles	5	
Valve Material	Noryl (1) or equivalent	
Regeneration	Down flow	
FLOW RATES		
Service @15psi/1 bar drop (includes bypass & meter)	102 lpm	
Backwash @25psi/1.7 bar drop (includes bypass)	102 lpm	
OPERATING PRESSURE		
Minimum/Maximum	330-600 kpa (48-100 psi)	
METER		
Accuracy	+- 5%	
Flow Rate Range	0.95-102lpm	
Volume Range	0.500-250.0 m ³	
Totaliser	0.001-9,999,000 m ³	
DIMENSIONS & WEIGHT		
Distributor Pilot	1.050" OD Pipe (3/4" NPS)	
Drain Line	3/4" (20mm) Hose Tail	
Brine Line	3/8" OD Poly Tube	
Mounting Base	2 /12" – 8 NPSM	
Height from Top of Tank	7 3/8" (187mm)	
Weight	4.5lbs (2kg)	
Distributor Pilot	12mm Above Tank Top	
ELECTRICAL SPECIFICATIONS		
Supply Voltage	230V AC	
Supply Frequency	50 Hz	
Output Voltage	12—16 V AC	
Output Current	500 mA	
CYCLES OF OPERATION		
	Range -times minutes	Factory Set
Backwash 1 st (upflow)	1-20	12
Regenerate draw/slow rinse (downflow)	1-99	70
Backwash 2 nd (upflow)	1-20 or OFF	OFF
Fast Rinse (downflow)	1-20 or OFF	10
Regenerant Refill (in service with treated water)	0.1 – 99.9	9
Service (downflow)		
<i>(Noryl is a trademark of General Electric)</i>		

Table of Contents

Specifications	10
Introduction	12
Special Features	
General Conditioner Information	12-13
How Your Conditioner Works	
Model E1 Control Front Panel	
Installation – important installation details.....	14-15
Bypass Valve	15-16
Screen Display Information and Programming Instructions	17-19
General Display Status	
Regeneration and Error Display Status	
Basic Button Function	
Water Conditioner Regeneration	20
Automatic Regeneration	
Manual Regeneration	
Care of Your Water Conditioner	20
General	
Cleaning the Injector/Injector Screen	
Maintaining the Drain Line	
Brine Line and Brine Tank Overflow Connection	21
Placing Softener into Operation	22
Valve Manual	23-25
Replacement Parts	26-38
Service Instructions.....	39-46
Troubleshooting	47-49
Alarms	
Troubleshooting Procedures	
Glossary of Terms	50

Safety

Caution

The plug-in transformer for this equipment is rated for indoor use only.

Warning

Never attempt to work on this control while standing in or near water without disconnecting electrical power to the control.

Introduction

The Model E1 Control provides sophisticated, demand-based water conditioning by incorporating a microprocessor and a water meter to electronically monitor the amount of water used daily. The control is factory programmed to regenerate when the volume throughput setting is reached at a present delayed time of 2am.

It is recommended to de-rate the throughput setting by one days general usage to ensure soft water is available on the day of regeneration. However in instances where this is not desired the control can be reprogrammed so that a regeneration can be initiated immediately on reaching the throughput setting.

The control provides efficient, trouble free, soft water.

The Series WS1-EI valve combines design simplicity with glass reinforced NORYL* plastic construction to provide an uncommonly reliable appliance.

If maintenance becomes necessary, the Model WS1-EI water Conditioner System has the capability for quick repairs.

NORYL is a trademark of GE Plastics.

Special Features

- **Memory Retention.** During a power outage, critical operating information in the control's memory is stored in a special electronic device called a NOVARAM. This information includes the time of day, water usage amounts, all programming data. When power is restored, the information is returned to the microprocessor and operation resumes as if an outage never occurred. The time of day will be late by the length of the power outage. Because most power outages are less than one minute in duration, it may be months or years before the time display requires resetting. If an outage of one or more hours occurs, the time of day should be reset but no other reprogramming is necessary.
- **Design Reliability.** Solid-state electronics assure many years of trouble-free performance. The metering system has only one moving part; a rotating turbine that measures water usage.
- **Time and Capacity Display.** During normal conditioning operation, the correct time of day and capacity can be accessed on the display. The capacity value is the number of cubic metres of water that the unit can condition before another regeneration is needed.
- **Flow indicator.** The display can access the actual flow rate through the system.
- **Throughput and Capacity Setting.** Once the capacity setting is entered, the information cannot

be lost due to a power outage, so reprogramming is not necessary.

- **Guest Cycle.** An extra regeneration can be achieved at any time by pressing the REGEN button on the front panel. It takes a few minutes for the regeneration to start. The unit completes the regeneration in about two hours. This feature is beneficial when you expect to use more than the normal amount of water; for example, guest visits or an extra heavy laundry day. The manual can be set for immediate regeneration of delayed regeneration at 2am.

General Conditioner Information

How Your Conditioner Works

In general, your water conditioner works in the following manner. Hard water flows into the conditioner and through the resin bed where calcium and magnesium hardness minerals are exchange. The conditioned water flows out of the resin bed into your plumbing system. After a certain amount of hard water has passed through the conditioner, the resin cannot remove any more minerals. This resin state is called exhaustion and indicates that the resin needs to be regenerated. The regeneration process restores the conditioner's ability to soften water. The control monitors the amount of water that flows through the conditioner and automatically calculates when to regenerate the resin bed.

Model E1 Control Front Panel

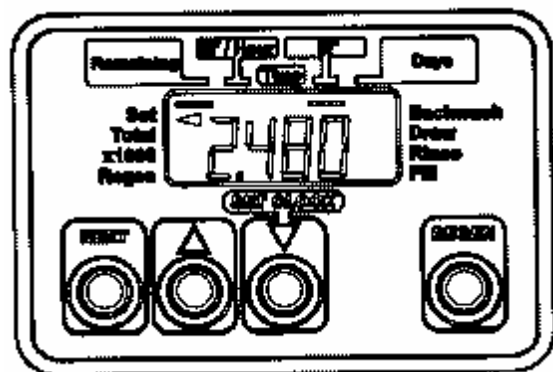

Figure 1

The main components of the model E1 Control front panel are:

- Main Display Screen with Cycle Time Remaining
- Display screen – set as 'remaining M³' or time of day
- Display can indicate Rate of Flow
- Four-Digit Display
- Programming Push Buttons

- REGEN Push Button
- Five-cycle operation provides for downflow conditioned water, upflow backwash, downflow brining and slow rinse, downflow fast rinse, and refill of the brine tank. Optional second backwash available.
- System operation cannot get out of phase or sequence. The control always returns to a fixed conditioned water position after regeneration.
- Bypass untreated water is automatically available during regeneration.



Installation

All plumbing and electrical connections must conform to local codes. Inspect the unit carefully for carrier shortage or shipping damage.

Location Selection

- Locate unit as close to a drain as possible
- If supplementary water treating equipment is required, make sure that adequate additional space is available. Locate the cabinet softener in an accessible place so that salt can easily be added.
- Do not install any unit closer than 3m (10ft) of piping between the outlet of the water conditioner and the inlet of the water heater. Water heaters can transmit heat back down the cold water pipe into the control valve. Hot water can severely damage the controller.

A 3m total pipe run (including bends, elbows etc) is a reasonable distance to prevent hot water damage. A positive way to prevent hot water from flowing from a heat source to the conditioner is to install a check valve in the soft water piping from the conditioner. If a check valve is installed, make sure that the water-heating unit is equipped with a properly rated temperature and pressure safety relief valve. Always conform to local codes.

- Do not locate the unit in an area where the temp ever falls below 1°C (34°F) or over 49°C (120°F).
- Do not install the unit near acid or acid fumes.
- Do not expose the unit to petroleum products.

Water Line Connection

A bypass valve system must be installed to provide for occasions when the water conditioner must be bypassed for hard water or for servicing. Bypass offers simplicity and ease of operation. These softeners are equipped as standard with a bypass valve. See pages 14 and 15

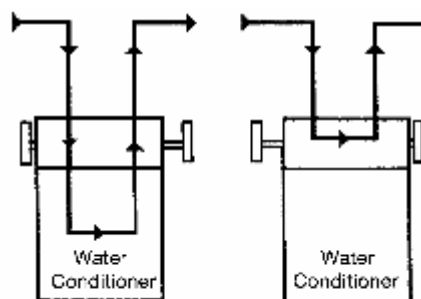

Figure 3 – Typ

Drain Line Connection – to sewer

The ideal location for the unit is above and not more than 6.1m (20ft) from the drain. For such installations, using the appropriate adaptor fitting (supplied), connect 12mm (1/2") plastic tubing to the drain line connection located on the top of the valve.

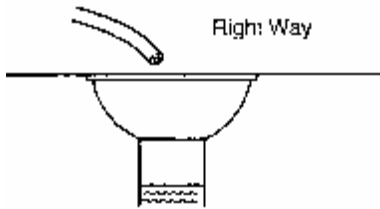

Figure 5 - Air Gap Installation

If the unit is located more than 6.1m (20ft) from the drain, use 20mm tubing for runs up to 12.0m. You may elevate the line up to 1.8m providing the run does not exceed 4.5m and the water pressure at the conditioner is not less than 280kPa (40psi.) You may elevate an additional 500mm for each additional 70kPa. (10psi) of water pressure.

When the drain line is elevated and empties into a drain which is below the level of the control valve, form a 170mm (7 inch) loop at the drain end of the line so that the bottom of the loop is level with the drain line connection. This provides an adequate siphon trap.

If the drain empties into an overhead sewer line, a sink-type trap must be used.

Caution

Never connect the drain line into a drain, sewer line or trap. Always allow an air gap between the drain line and the wastewater to prevent the possibility of sewage being back-siphoned into the conditioner.

ot In Bypass In Bypass

Important Installation Details

The control valve, fittings and/or bypass are designed to accommodate minor plumbing misalignments but are not designed to support the weight of the system or the plumbing.

Do not use Vaseline, oils, other hydrocarbon lubricants or spray silicone anywhere. A silicone lubricant may be used on black o-rings but is not necessary. **Avoid any type of lubricants, including silicone, on the clear lip seals.**

The nuts and caps are designed to be unscrewed or tightened by hand or with the special plastic wrench. Do not use a pipe wrench to tighten or loosen nuts or caps. Do not place a screwdriver in the slots on caps and/or tap with a hammer.

Do not use pipe dope or other sealant on threads. Use teflon tape on threaded inlet, outlet and drain fittings. Teflon tape is not necessary on the nut connection or caps because of o-ring seals.

After completing any valve maintenance involving the drive assembly of the drive camp assembly and pistons, press and hold NEXT and REGEN buttons for 3 seconds or unplug power source jack from the printed circuit board (black wire) and plug back in. This resets the electronics and establishes the service piston position. The display should flash all wording, then flash the software version and then reset the valve to the service position.

All plumbing should be done in accordance with local plumbing codes. The pipe size for the drain line should be a minimum of 12mm.

Solder joints near the drain must be done prior to connecting the drain line flow control fitting. Leave at least 150mm (6") between the drain line control fitting and solder joints when soldering pipes that are connected on the drain line control fitting. Failure to do this could cause interior damage to the drain line flow control fitting.

When assembling the installation fitting package (inlet and outlet), connect the fitting to the plumbing system first and then attach the nut, split ring and o-ring. Heat from soldering or solvent cements may damage the nut, split ring and o-ring. Solder joints should be cool and solvent cements should be set before installing the nut, split ring or o-ring. Avoid getting primer and solvent cement on any part of the o-rings, bypass valve or control valve.

Position the softener within 1 ½ metres of a 10 amp GPO. The transformer is connected into the plug socket on the back of the valve control panel. Do not

drop the transformer or have the cable too taut. The transformer is only suitable for **internal use only**. For full understanding of the water softener we recommend that the instruction manual be fully read before installation and commissioning of the softener by undertaken.

IMPORTANT: A NUMBER OF VALVE COMPONENTS ARE LOCKED INTO POSITION WITH EASILY REMOVABLE CLIPS. ENSURE ALL LOCKING CLIPS ARE CORRECTLY IN POSITION BEFORE PRESSURISING THE SOFTENER. ENSURE THAT IT IS POINTED OUT TO ALL RELEVANT PERSONNEL THAT THE LOCKING CLIPS MUST NOT BE REMOVED WHILST THE SYSTEM IS UNDER WATER PRESSURE.

Note: All electrical connections must be connected according to local codes.

Install grounding strap on metal plates.

Bypass Valve

The bypass valve is typically used to isolate the control valve from the plumbing system's water pressure in order to perform control valve repairs or maintenance. The WS1 bypass valve is particularly unique in the water treatment industry due to its versatility and state of the art design features. The full flow bypass valve incorporates four positions, including a diagnostic position that allows service personnel to work on a pressurised system while still providing untreated bypass water to the facility or residence. Its completely non-metallic, all plastic design allows for easy access and serviceability without the need for tools.

The bypass body and rotors are glass filled Noryl (or equivalent) and the nuts and caps are glass filled polypropylene. All seals are self-lubricating EPDM to help prevent valve seizing after long periods of non-use. Internal o-rings can easily be replaced if service is required.

The bypass consists of two interchangeable plug valves that are operated independently by red arrow-shaped handles. The handles identify the flow direction of the water. The plug valves enable the bypass valve to operate in four positions.

1. **Normal Operation Position:** The inlet and outlet handles point in the direction of flow indicated by the engraved arrows on the control valve. Water flows through the control valve during normal operation and this position also allows the control valve to isolate the media bed during the regeneration cycle. (Figure 1)
2. **Bypass Position:** The inlet and outlet handles point to the centre of the bypass, the control valve is isolated from the water pressure contained in the plumbing system. Untreated water is supplied to the plumbing system. (Figure 2)
3. **Diagnostic Position:** The inlet handle points in the direction of flow and the outlet handle points to the centre of bypass valve, system water pressure is allowed to the control valve and the plumbing system while not allowing water to exit from the control valve to the plumbing.(Figure 3)
4. **Shut Off Position:** The inlet handle points to the centre of the bypass valve and the outlet handle points in the direction of flow, the water is shut off to the plumbing system (i.e. plumbing connection somewhere in the building bypasses the system). (Figure 4)

Figure 1

NORMAL OPERATION

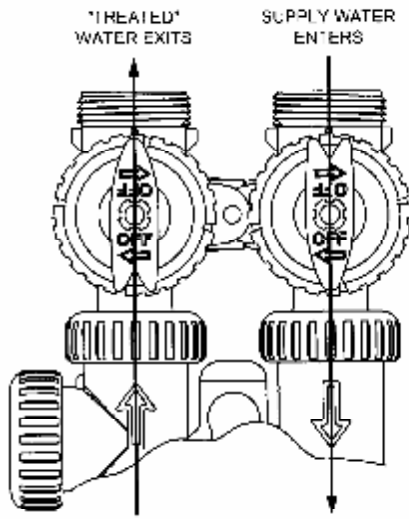

Figure 2

BYPASS OPERATION

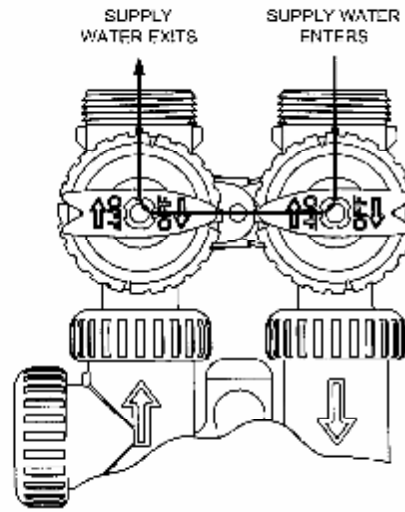

Figure 3

DIAGNOSTIC MODE

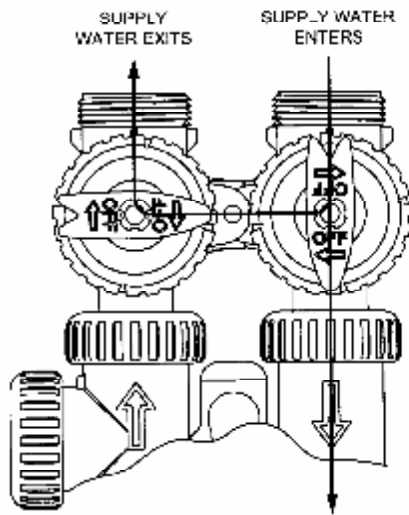
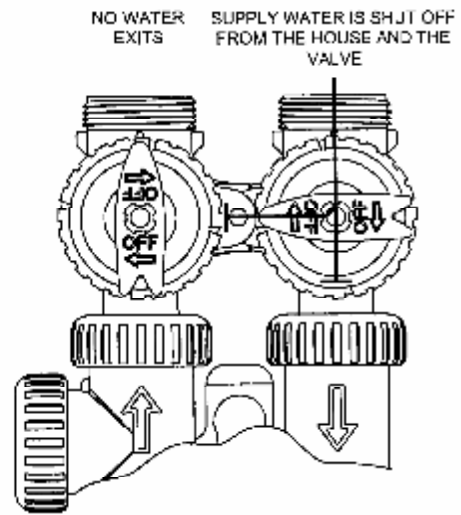

Figure 4

SHUT OFF MODE



WS1EI
Screen Display Information
And
Programming Instructions

General Operation

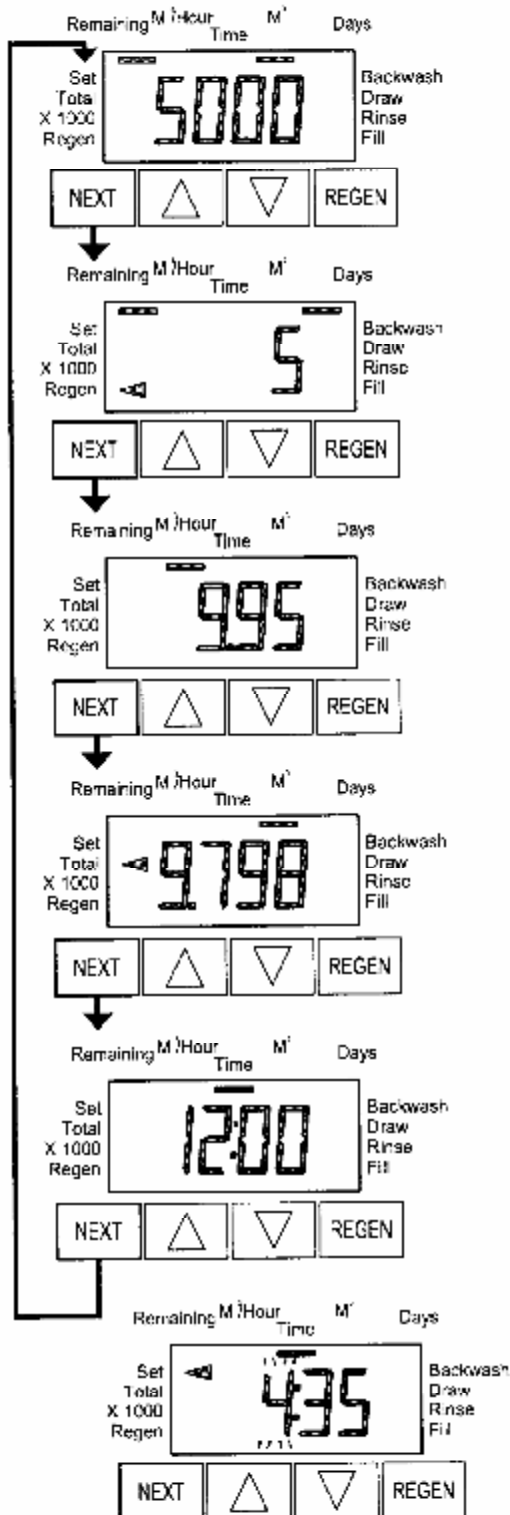

General Display

When the system is operating, one of four displays may be shown. Pressing NEXT will alternate between the displays shown below.

User 1

Shows volume remaining to regeneration.

User 3

Displays flow rate M³/hour.

User 4

Displays total flow in cubic metres since last reset. Can be used to estimate average daily usage.

PRESS DOWN ARROW FOR 3 SECONDS TO RESET TO ZERO.

User 5

Shows current time.

Setting Time of Day

Push NEXT button until time of day screen is displayed. Press and hold the ▼ or ▲ arrow until the correct hour is displayed.

Then press NEXT button. The minutes will flash. Press the ▲ or ▼ arrow until correct minute is displayed.

Press the NEXT button to return to the display screens. If the NEXT button is not pressed hours or minutes will flash for five minutes before returning to display screens.

General Regeneration Error Screens Status

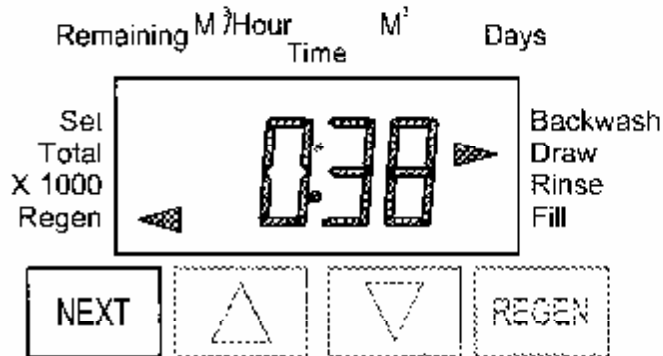

Regen Screen

Displays the time remaining in the current cycle. Pressing REGEN advances to the next cycle.

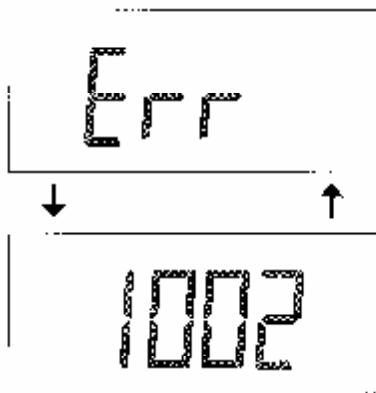

Error Screen

Alternated flashing Err and error code every 3 seconds. Clear by disconnecting the power supply at the PC board and reconnecting, or press the NEXT and REGEN buttons simultaneously for 3 seconds.

Button Operation and Function

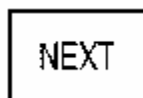

Scrolls to the next display.

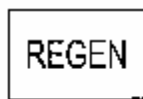

Pressing once and releasing will schedule a regeneration at the present delayed regeneration time.
 Pressing again and releasing will cancel the regeneration.
 Pressing and holding for 3 seconds will initiate an immediate regeneration.
 Pressing while in regeneration will advance to the next cycle.
 Pressing in the program levels will go backwards to the previous screen.

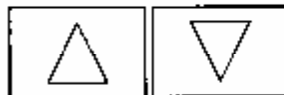

Changes variable being displayed.

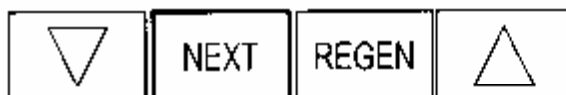

Key sequence to lock and unlock program settings.



Holding for 3 seconds initiates a control reset. The software version is displayed and the piston returns to the home/service position, resynchronizing the valve.

Water Conditioner Regeneration

Your water conditioner regenerates for one of two reasons:

- The control determines that the conditioner has reached the throughput setting volume capacity.
- The REGEN button was pressed.

Automatic Regeneration

The control makes regeneration decisions based on the amount of water that has flowed through the conditioner and the programmed throughput figure.

The factory setting for Time of Regeneration is 2:00 AM. You can change this time. Refer to the **Customer/Installer Programming Instructions** section in this manual for additional information.

Manual Regeneration

To force the control to perform a regeneration, press the REGEN push button. This button is located on the front of the control. When you press the REGEN button, the control performs a full regeneration of the conditioner. You can use this feature if you need a large amount of conditioned water but the capacity remaining is low.

Note: If you press this button once and release immediately. The regeneration will occur at the delayed time setting i.e. 2am. If an immediate regeneration is required then hold in the button for 3 seconds.

Care of Your Water Conditioner

General

Check the salt level in the salt storage tank regularly. Always maintain the salt level above the water level for a consistent salt dosage and proper water conditioner operation. Don't allow the conditioner to run out of salt before refilling. When refilled, the salt storage tank contains enough salt to support numerous resin bed regenerations. It is recommended to utilise a high grade water softener salt like IBC premium grade. Do not use a fine grade of salt. Have the salt storage tank serviced once a year to remove accumulated sediment that may impede brine draw.

Cleaning the Injector/Injector Screen

The injector is the component, which creates the vacuum necessary to draw the brine into the water conditioner. Clean the injector and the injector screen once a year in order to maintain proper water conditioning. Some locations may require more frequent injector and screen servicing.

Complete the following steps to clean the injector and the injector screen:

1. Unplug the wall mount transformer.
2. Shut off the water supply or put the bypass valve into the bypass position.
3. Depressurise the pipework by opening a tap in the service line.
4. Unscrew the injector cap (large top slotted cap) and lift off. Loosen cap with special plastic wrench or pliers if necessary. Attached to the injector cap is a screen. Remove the screen and clean if fouled.

The injector can be pried out with a small screwdriver. The injector consists of a throat and nozzle. Chemically clean the injector with vinegar. The holes can be blown out with air. Both pieces have small diameter holes that control the flow rates of water to insure that the proper concentration of regenerant is used. Sharp objects, which can score the plastic, should not be used to clean the injector. Scoring the injector or increasing the diameter of the hole could change the operating parameters of the injector. Push the injector firmly in place, replace the screen and hand tighten the injector cap.

5. Close off the tap in service line and reposition bypass valve back into service position.

Maintaining the Drain Line

The drain line discharges and brine during the regeneration cycle. Typically, the line drains into a sewer connection. The installer should plumb the drain line according to local codes, leaving a one or two inch air gap between the end of the drain line and the drain opening.

Be sure that the drain line remains unrestricted so the regeneration water and brine can flow freely to the drain. Do not set objects on the drain line that could crimp the line and restrict flow.

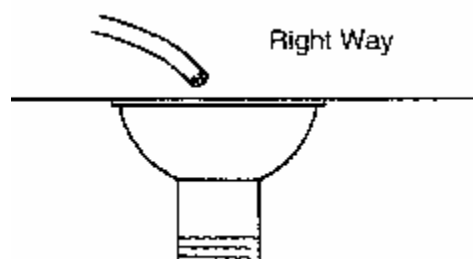

Brine Line Connection

The brine line comprises a pick up air check assembly installed in the brine wall in the cabinet and connected by tubing to the brine elbow on top of the valve.

Note: Make sure that all fittings and connections are tight so that premature checking does not take place. Premature checking occurs when the ball in the air check seals before all brine is drawn out of the brine tank. Refer to the **Troubleshooting** section in this manual for additional information.

Brine Tank Overflow Line Connection

In the event of a malfunction, the tank overflow connection directs overflow to the drain instead of spilling on the floor where it could cause water damage. Complete the following steps to connect the overflow fitting to the brine tank:

1. Locate the fitting overflow on the side of the brine tank.
2. Attach a length of 1/2in (1.3cm) tubing (not supplied) to the fitting and run to the drain.

Note: Do not elevate the overflow line higher than 3in (7.6cm) below the bottom of the overflow fitting. Do not tie into the drain line of the control unit. The overflow line must be a direct, separate line from the overflow fitting to the drain, sewer or tube. Allow an air gap as in the drain line connection.

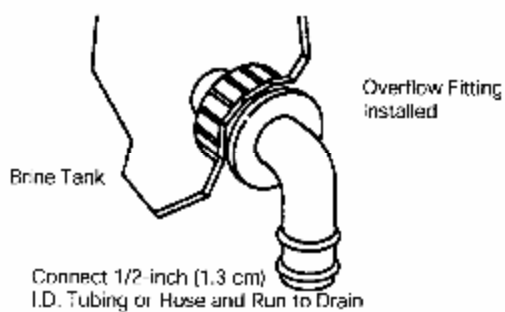

Overflow Line Connection

Placing Softener into Operation

Initial Start-Up

1. Mains water turned off to unit or bypass valve in shut off mode.
2. Connect transformer to power point and turn on.
3. Program controller as per "Customer/Install Programming Instructions".
4. Press the "Regen" button in and hold for 3 to 5 seconds.
5. The softener will advance to the backwash position and start counting down.
6. Slowly open the inlet valve or the bypass valve into the "Diagnostic Mode" approximately one quarter of a turn and allow the mineral tank to slowly fill up with water.

Caution

If the water supply valve is opened too rapidly or too far, resin may be lost. In the BACKWASH position, you should hear air escaping slowly from the drain line.

7. When all the air is purged from the tank (water begins to flow steadily from the drain), slowly open the main supply valve all the way. Allow the water to run into the drain until the water appears clear. Turn off the water supply and wait for a few minutes to allow all trapped air to escape from the tank. Then open the inlet valve/bypass inlet slowly and allow the backwash to time down.
8. Press the "regen" button and allow valve to position into the draw cycle. Once the valve is positioned and display registering a time down then again press "regen" and allow to advance to rinse – Once again when display starts to count down press "regen" button.
9. Display will register a small backwash time and then move down to fill.
10. Allow to fill the brine compartment. Check that water is slowly flowing into the brine well by lifting up the brine well cap.
11. Allow to time out and note water level in brine compartment. The compartment should have been prior filled with salt. The valve will then go back into the service mode.
12. Allow the salt to dissolve in the brine compartment for at least 30 minutes.
13. It is recommended to give a new softener a complete regeneration before placing fully into service.
14. Press and hold the "regen" button until the display starts to blink and go into the backwash mode.
15. Allow to count down to the draw mode. When the valve is in this mode and counting down check to see that brine is being drawn out of the cabinet into the valve. The brine draw is very slow and all brine will be drawn out until the air check on the brine riser tube shuts off. The system will then remain in the draw cycle to slowly rinse (And regenerate) the brine through the resin.
16. Allow the system to complete a full regeneration and return to the service position. This will take a few hours.
17. When the unit has returned to the service position with the normal display then open the bypass valve outlet valve slowly to enable water to enter the treated water line ensure that the bypass valve is correctly in "Normal Operation" position.
18. Open a tap in the treated water and allow to run to drain for a few minutes. Then check the harness of the water with the supplied test kit. If not soft allow to run to drain for 5 minutes and recheck the hardness. Refer to "troubleshooting" section if the water is still hard.

WS1EI Manual

Control Valve Function and Cycles of Operation

This glass filled Noryl¹ (or equivalent) fully automatic control valve is designed as the primary control center to direct and regulate all cycles of a water softener. The control valve can be set to regenerate on demand (consumption of a predetermined amount of water) and/or as a time clock (passage of a particular number of days). The control valve is factory set to regenerate on demand consumption with a delay regeneration set for 2am.

The control valve is compatible with a variety of resin cleaners. The control valve is capable of routing the flow of water in the necessary paths to regenerate water treatment systems. The injector regulates the flow of brine. The control valve regulates the flow rates for backwashing, rinsing and the replenishing of treated water into a regenerant tank.

The control valve uses no traditional fasteners (e.g. screws); instead clips, threaded caps, nuts and snap type latches are used. Caps and nuts only need to be firmly hand tightened because radial seals are used. Tools required to service the valve include one small blade screw driver, one large blade screw driver, pliers and a pair of hands. A plastic wrench is available which eliminates the need for screwdrivers and pliers. Disassembly for servicing takes much less time than comparable products currently on the market. Control valve installation is made easy because the distributor tube can be cut 12.7mm ($\frac{1}{2}$ ") above to 12.7 mm ($\frac{1}{2}$ ") below the top of tank thread. The distributor tube is held in place by an o-ring seal and the control valve also has a bayonet lock feature for upper distributor baskets.

The AC adapter power pack comes with a 2.0 meter power cord and is designed for use with the control valve. The AC adapter power pack is for dry location use only.

- Solid state microprocessor with easy access front panel settings.
- Front panel display for time of day, volume remaining, current flow rate and total volume used (Totalizer).
- Four methods to initiate regeneration; meter immediate, meter delayed, time clock delayed or pressure differential.
- Optional double backwash feature offers optimum regeneration cleaning ability and efficiency.

- Fully adjustable 6-cycle control delivers controlled backwash, downflow brining/slow rinse, second backwash, fast rinse, refill and downflow service.
- Downflow regeneration.
- 12-volt output AC Adapter provides safe and easy installation.
- Control valve design provides optimum service and backwash rates.
- Treated water regenerant refill.
- Reliable and proven DC Drive.
- **General Factory set up is for M³ throughput regeneration with 2 AM delayed regeneration and No second Backwash.**

Manual Initiated Regeneration

The user can initiate manual regeneration. The user has the option to request the manual regeneration at the delayed regeneration time of 2am or to have the regeneration occur immediately:

1. Pressing and releasing immediately the REGEN button. "f" will flash towards regen on the display and regeneration will occur at 2am the delayed regeneration time. The user can cancel the request by pressing and releasing the REGEN button.
2. Pressing and holding the REGEN button for approximately 3 seconds will immediately start the regeneration. The user cannot cancel this request, except by resetting the control by pressing NEXT and REGEN buttons simultaneously for 3 seconds.

However this may totally clear all the pre-programmed in functions and is not recommended.

The WS1EI control valve consist of the following components:

1. Drive Assembly
2. Drive Cap Assembly, Main Piston and Regenerant Piston.
3. Spacer Stack Assembly.
4. Injector Cap, Screen, Injector.
5. Refill Flow Control Assembly.
6. Drain Line Flow Control and Fitting Assembly.
7. Water Meter.
8. Bypass Valve.
9. Installation Fitting Assemblies.

Drive Assembly

The drive assembly consists of the following parts:

- Drive Bracket.
- Printed Circuit (PC) Board.
- Motor
- Drive Gears
- Drive Gear Cover

The drive bracket holds the PC board, the motor, the drive gears and the drive gear cover in place.

The PC board receives and retains information, displays the information, determines when to regenerate and initiates regeneration. The display show different types of information in the initial system set up, installer display settings, diagnostics or user display settings.

The PC board powers the motor. The PC board's two-prong jack connects wires to the direct current (DC) motor. The motor is held in place on the drive bracket by a spring-loaded clip and a small bulge in the plastic, which fits in one of the slots on the motor housing. The motor turns drive gears that drive the piston to cycle positions for backwashing, regeneration, rinsing, refill or service. The motor is fully reversible (turns both ways) and changes direction of rotation to change the direction of piston motion. The motor is easily replaced if necessary.

There are three drive gears held in place by the drive gear cover. All three drive gears are the same size. A reflective coating is applied to the gears. As the centre drive gear turns a light shines on the coating and a light sensing diode determines if a light pulse was returned. The PC board counts the pulses and determines when to stop driving the motor.

Drive Cap Assembly, Main Piston and Regenerant Piston

The drive gears turn the main gear of the drive cap assembly, which moves the piston. The screw-driven, horizontally moving piston stops at specific positions to direct the flow of water to backwash, regenerate, rinse or refill. The PC board determines the position of the piston by counting pulses produced when the piston is moved. An optical sensor looking at one of the reduction drive gears generates these pulses. Each cycle position is defined by a number of pulses. The counter is zeroed each time the valve goes to the service position. The PC board finds the service position by noting the increase in current delivered to the motor when the mechanical stop at the service position is reached. This method of controlling the piston position allows for greater flexibility and requires no switches or cams (U.S. Patent 6,444,127).

Spacer Stack Assembly

The spacer stack assembly provides the necessary flow passage for water during the different cycles. The all-plastic spacer stack assembly (U.S. Patent 6402944) is a one-piece design which allows the stack to be removed using your fingers.

The exterior of the stack is sealed against the body bore with self lubricating EPDM o-rings, while the

interior surface is sealed against the piston using slippery self cleaning silicone lip seals. The lip seals are clear in colour and have a special slippery coating so that the piston does not need to be lubricated.

Injector Cap, Screen, Injector Plug and Injector

The screen, injector and/or injector plug(s) are installed under the injector cap in an easy to access location on top of the valve. The injector cap contains four slots so no water accumulates in the cap. The injector cap is designed to be hand tightened.

Under the injector cap there is an easy to clean removable screen to prevent fouling of the injector. There are two holes under the injector cap labelled "DN" and "UP". The injector is in the "DN" hole and the "Up" hole is plugged.

The injector lets water pass through the pathway. The self-priming injector increases the velocity of the water, creating a zone of negative pressure that draws in the concentrated liquid regenerant sodium chloride (brine). The regenerant blends with the stream of water which passes through the media to regenerate the resin bed.

The injector provides a consistent regenerant/water mixture ratio over the entire operating pressure range of the control valve. The injector provides good performance in a variety of applications. The injector fitted has been used to suit a wide range of operating pressures. But requires a minimum of 330 kpa to function correctly.

Injector Order Information

Injector order number	Injector colour	Typical tank Diameter*
V3010-1B	Brown	7"
V3010-1D	Red	9"
*V3010-1E/F	White/Blue	10"
V3010-1G	Yellow	12"
V3010-1I	Orange	13"
V3010-1K	Light Green	14"

* Will vary with Tank Resin Volume Check with Factory

Refill Flow Control Assembly or Refill Port Plug

The refill flow control assembly consists of a refill flow elbow, refill flow control retainer assembly, refill flow control, polytube insert and nut assembly. The refill flow control retainer fits in the refill elbow. The refill

flow control retainer houses the refill flow control which controls the flow rate when the regenerant tank is being refilled. The refill flow control is a flexible washer-like part with a small orifice and a precision moulded contour that delivers a steady 1.91pm (0.5 gpm) regenerant tank refill rate at varying inlet pressures. Refill is accomplished with treated water.

The refill flow control assembly is installed in an easy to access refill elbow located on top of the control valve. The refill flow control assembly is installed in an easy to access refill elbow located on top of the control valve. The refill flow control assembly is attached to the control valve with a locking clip. The locking clip allows the elbow to rotate 270 degrees so the outlet can be orientated towards the regenerant tank.

The control valve has a standard refill elbow to which a 3/8" flexible tube can be connected. Always utilise the supplied Tube insert.

Drain Line Flow Control and Fitting Assembly

The drain line flow control assembly includes a drain line flow control and a fitting. The drain line flow control allows proper media bed expansion by regulating the flow rate to the drain. The drain line flow control is a flexible washer-like part with an orifice and a precision moulded contour. The flow rates are within $\pm 10\%$ over the pressure range of 1.4 bar (20 psi) to 8.6 bar (125 psi).

The drain line flow control and fitting are located on top of the control valve and replaceable without the use of special tools.

The drain line flow control can be installed in the standard 3/4" drain line elbow, which accommodates 5/8" polytube or pipe 20mm threaded drain line connections. The optional nut and polytube insert for the drain line elbow is designed for use with flexible polytube only. The drain line elbow can be rotated 180 degrees so the outlet can be orientated to the nearest drain. This model softener is fitted with a 20mm push on hose elbow.

Water Meter or Meter Plug

The water meter is installed on the outlet side of the control valve. The water meter uses a turbine to measure cubic metres of treated water. The turbine rotates with the flow of water and reports its rate of rotation through Hall effect³ circuitry to the printed circuit (PC) board. This rotation permits the PC board to record the total volume of treated water and the flow rate. The small centrally located magnet is shielded from water, which substantially reduces iron-fouling problems with the turbine.

The turbine is accurate to within $\pm 5\%$ over a wide operating flow rate range 0.95 lpm (0.25 gpm) up to control valve maximums and has a very low pressure drop. Water used for regeneration is not metered. If the control valve is in regeneration mode (e.g. a backwash cycle) and there is a water demand, that water usage is not metered.

When facing the front of the control valve, the water meter is positioned on the left-hand side of the control valve. Allow sufficient clearance to clean and repair the water meter without disconnecting the plumbing or disassembling any other parts of the control valve.

Water Meter Hall Effect Explanation

³ Some semiconductor materials exhibit a phenomenon in the presence of a magnetic field that is adaptable to sensing devices. When a current is passed through one pair of wires attached to a semiconductor will develop a voltage proportional to the magnetic field present and the current in the other pair of wires. Holding the exciting current constant and moving a permanent magnet near the semiconductor, produces a voltage output proportional to the movement of the magnet. Hall effect devices provide a high speed response, excellent temperature stability, and no physical contact.

Installation Fitting Assemblies

The installation fittings are used to connect the bypass to the plumbing system. Standard fittings supplied are a 25mm BSP female PVC elbow assembly.

Both elbow fittings have a unique drill out feature to allow a 1/4" NPT connection to the inlet and/or outlet which can be used for a RO feed, test ports, pressure tap ports, etc.

**SPARE PARTS
AND
SERVICING INSTRUCTIONS**

WS1E1 Front Cover and Drive Assembly

Drawing No.	Order No.	Description	Quantity
1	V3175EI-01	WS1EI Front Cover Assembly	1
2	V3107-01	WS1 Motor	1
3	V3106-01	WS1 Drive Bracket & Spring Clip	1
4	V3408E1	WS1.5 PC Board EI	1
5	V3110	WS1 Drive Gear 12x36	3
6	V3109	WS1 Drive Gear Cover	1
	V3002EI	WS1EI Drive ASY	*
Not Shown	V3186-01	WS1 AC ADAPTER CORD ONLY	1

* Drawing number parts 2 through 6 may be purchased as a complete assembly, part V3002EI.

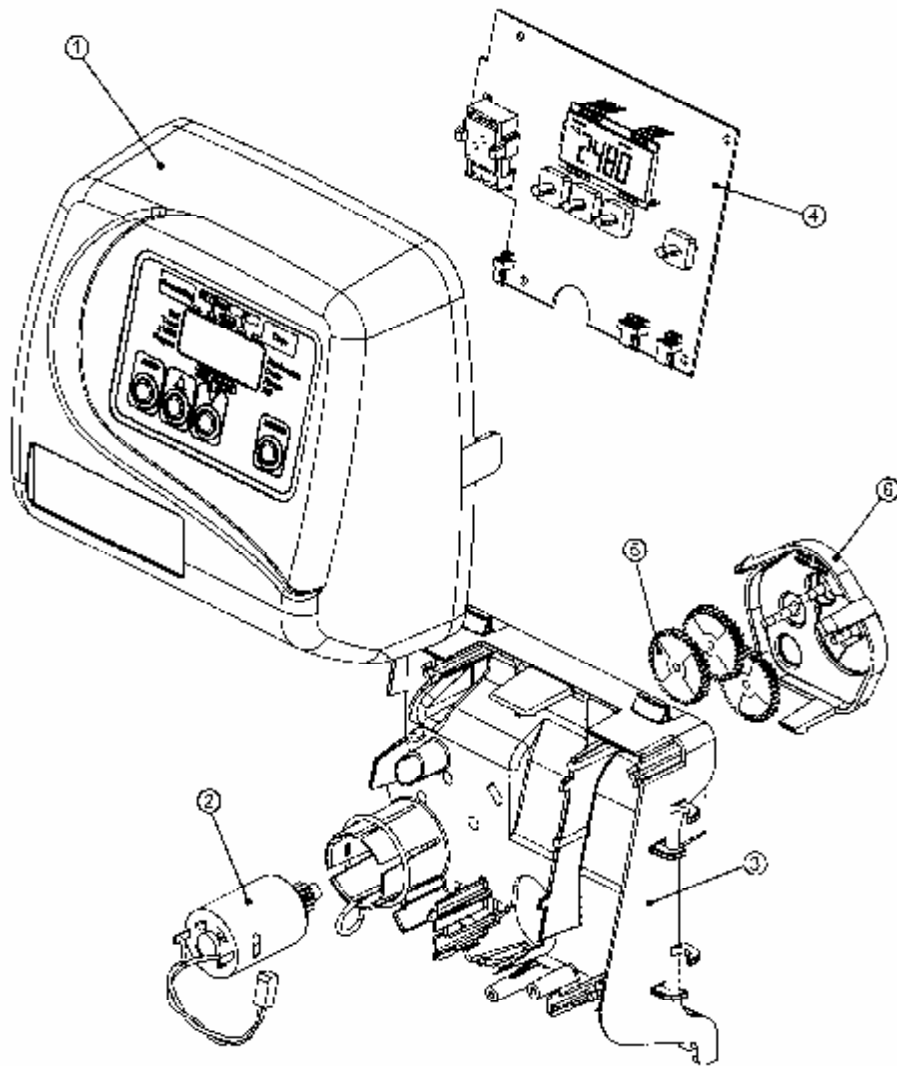

WE1EI Drive Cap Assembly, Downflow Piston, Regenerant Piston and Spacer Stack Assembly

Drawing No.	Order No.	Description	Quantity
1	V3005	WS1Spacer Stack Assembly	1
2	V3004	Drive Cap ASY	1
3	V3178	WS1 Drive Back Plate	1
4	V3011*	WS1 Piston Downflow ASY	1
5	V3174	WS1 Regenerant Piston	1
6	V3135	O-ring 228	1
7	V3180	O-ring 337	1
8	V3105	O-ring 215 (Distributor Tube)	1
Not Shown	V3001	WS1 Body ASY Downflow	1

*V3011 is labelled with DN.

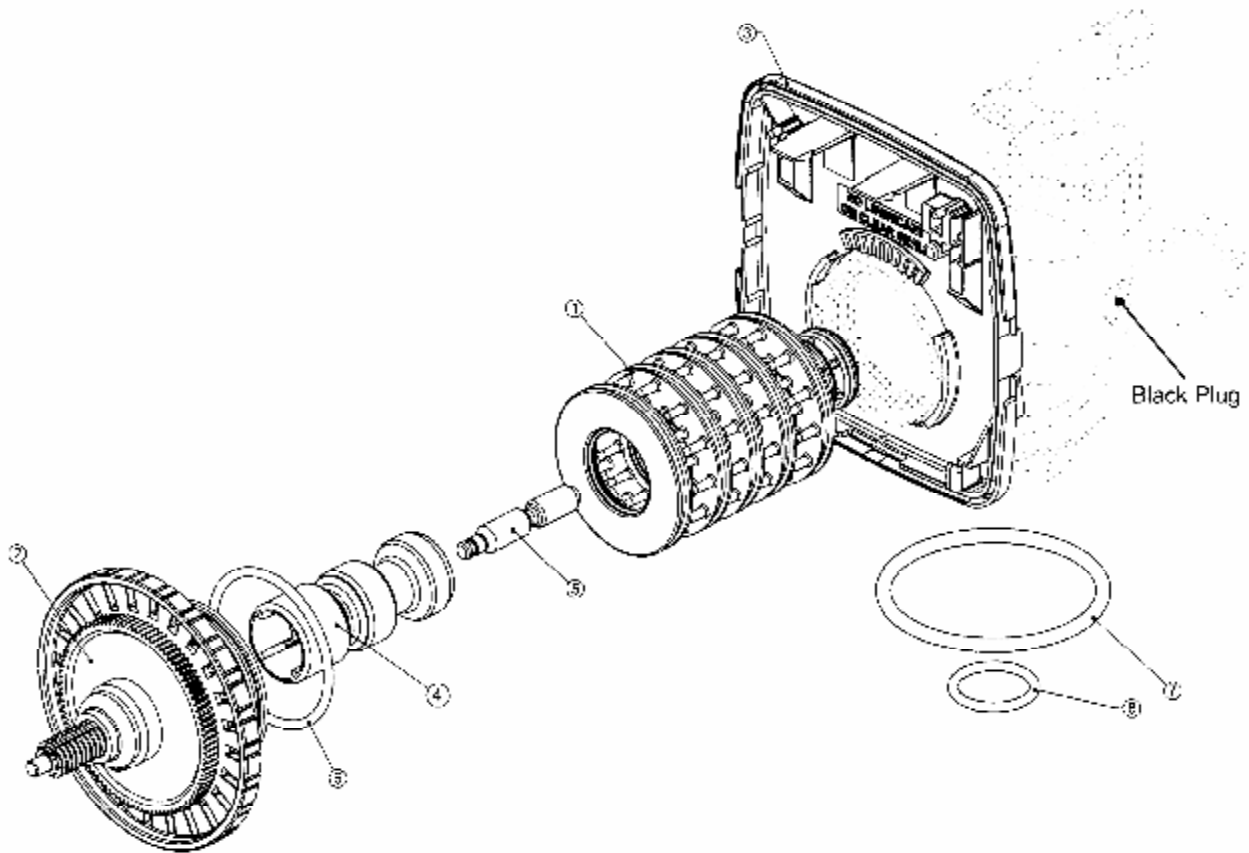

Injector Cap, Injector Screen, Injector, Plug and O-Ring

Drawing No.	Order No.	Description	Quantity
1	V3176	Injector Cap	1
2	V3152	O-ring 135	1
3	V3177	Injector Screen	1
5	V3010-1A	WS1 INJECTOR ASSY - BLACK	1
	V3010-1B	WS1 INJECTOR ASSY - BROWN	
	V3010-1C	WS1 INJECTOR ASSY - VIOLET	
	V3010-1D	WS1 INJECTOR ASSY - RED	
	V3010-1E	WS1 INJECTOR ASSY - WHITE	
	V3010-1F	WS1 INJECTOR ASSY - BLUE	
	V3010-1G	WS1 INJECTOR ASSY - YELLOW	
	V3010-1H	WS1 INJECTOR ASSY - GREEN	
	V3010-1I	WS1 INJECTOR ASSY - ORANGE	
	V3010-1J	WS1 INJECTOR ASSY - LIGHT BLUE	
	V3010-1K	WS1 INJECTOR ASSY - LIGHT GREEN	
Not Shown	V3170	O-ring 011	*
Not Shown	V3171	O-ring 013	*

- The injector plug has one 011 (lower) and 013 (upper) o-ring.

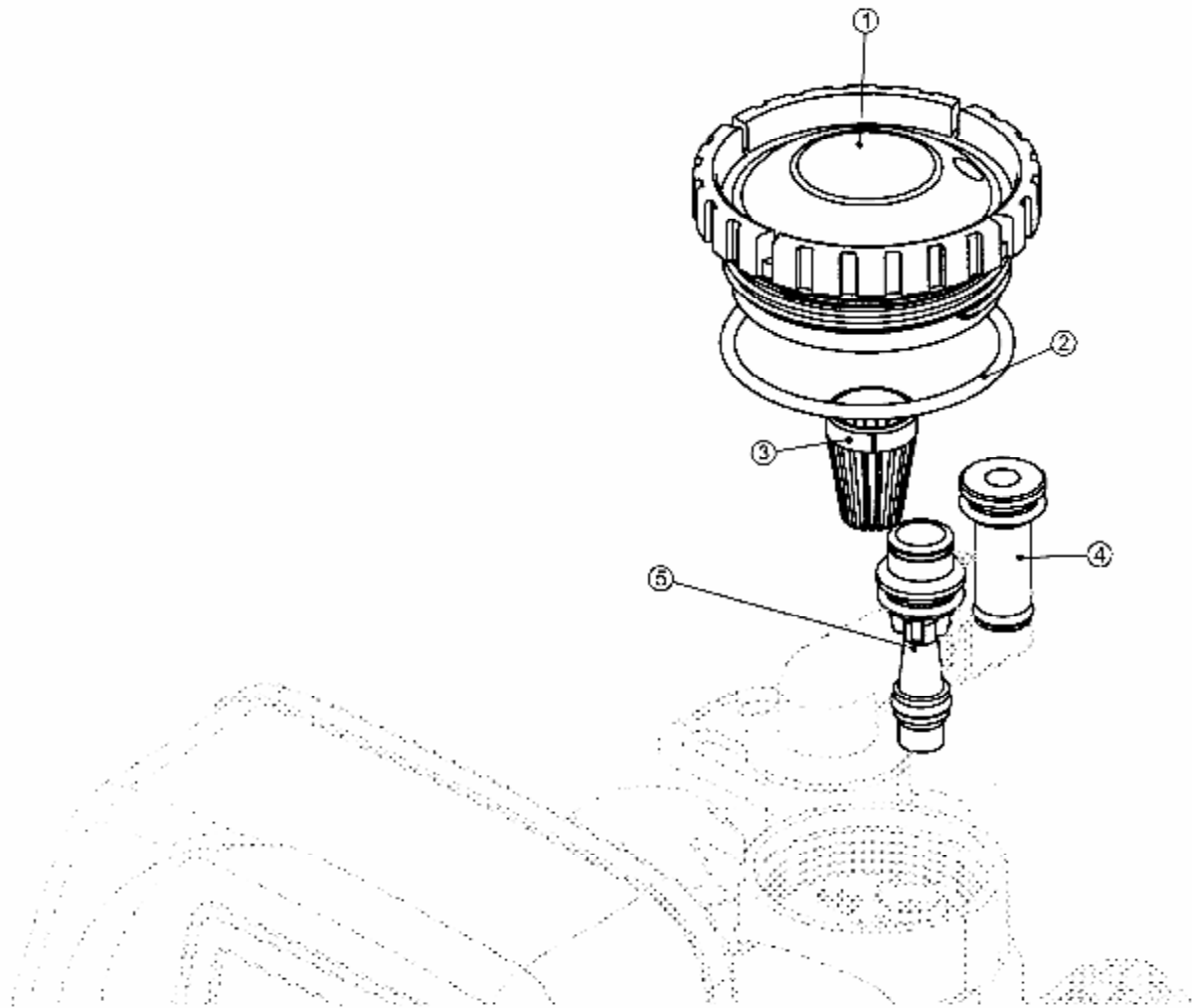

Refill Flow Control Assembly

Drawing No.	Order No.	Description	Quantity
2	H4615	Elbow Locking Clip	1
3	JCP-P-6	Polytube insert 3/8"	1
4	JCPG-6PBLK	Nut 3/8"	1
5	H4613	Elbow Cap 3/8"	1
6	V3163	O-ring 019	1
7	V3165-01*	WS1 RFC Retainer ASY	1
8	V3182	WSC RFC	1
Not Shown	H4650	Elbow 1/2" with nut and insert	Option

* Assembly includes V3182 WS1 RFC.

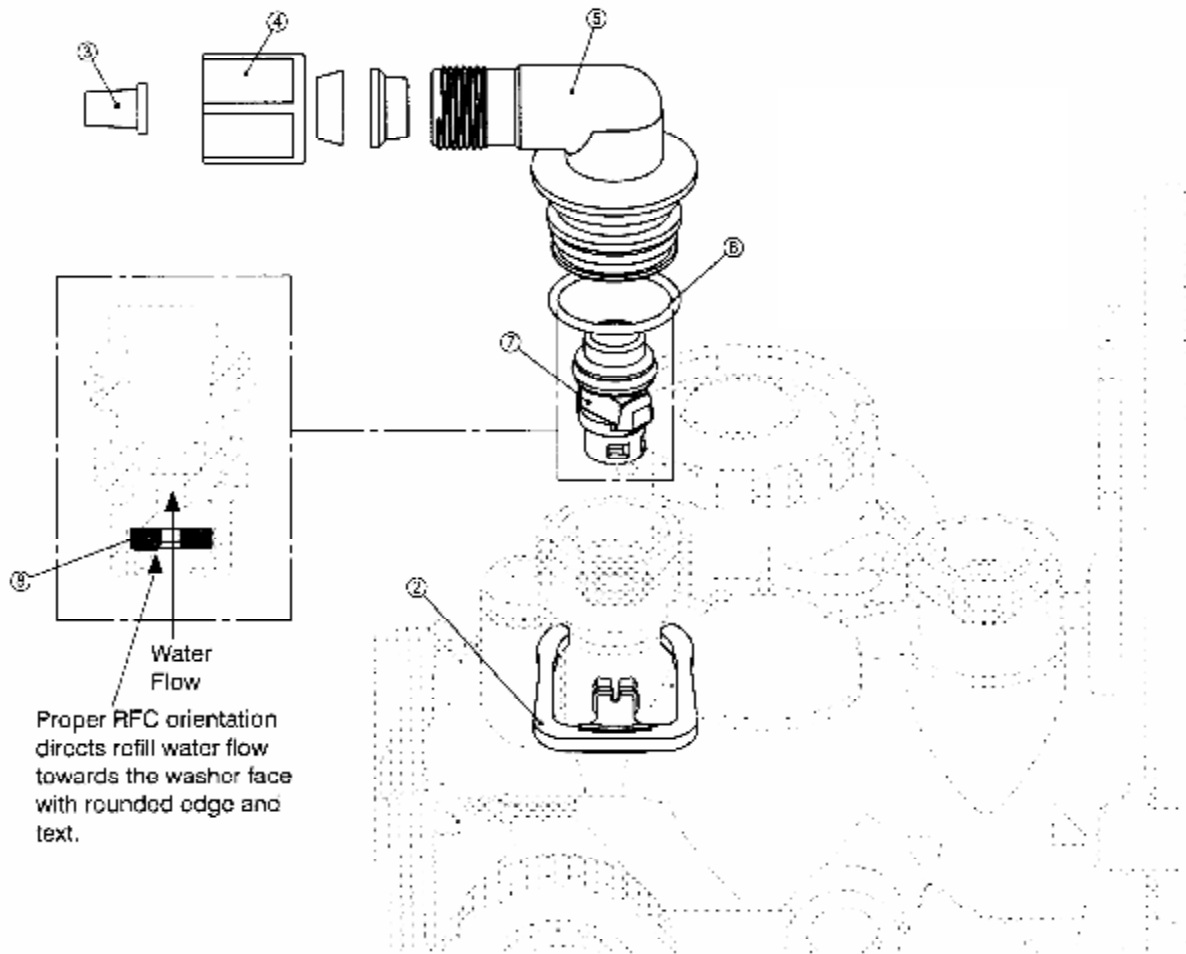

Drain Line – 3/4"

Drawing No.	Order No.	Description	Quantity
1	H4615	Elbow Locking Clip	1
2	PKP10TS8-BULK	Polytube insert 5/8	Option
3	V3192	WS1 Nut 3/4 Drain Elbow	Option
4	V3158-01	WS1 Drain Elbow 3/4 Male	1
5	V3163	O-ring 019	1
6	V3159-01	WS1 DLFC Retainer ASy	1
7	V3162-007	WS1 DLFC 0.7 gpm for 3/4 2.6 lpm	One DLFC must be used if 3/4 fitting is used
	V3162-010	WS1 DLFC 1.0 gpm for 3/4 3.8 lpm	
	V3162-013	WS1 DLFC 1.3 gpm for 3/4 4.9 lpm	
	V3162-017	WS1 DLFC 1.7 gpm for 3/4 6.5 lpm	
	V3162-022	WS1 DLFC 2.2 gpm for 3/4 8.3 lpm	
	V3162-027	WS1 DLFC 2.7 gpm for 3/4 10.2 lpm	
	V3162-032	WS1 DLFC 3.2 gpm for 3/4 12.1 lpm	
	V3162-042	WS1 DLFC 4.2 gpm for 3/4 16 lpm	
	V3162-053	WS1 DLFC 5.3 gpm for 3/4 20 lpm	
	V3162-065	WS1 DLFC 6.5 gpm for 3/4 24.7 lpm	
	V3162-075	WS1 DLFC 7.5 gpm for 3/4 28.5 lpm	
	V3162-090	WS1 DLFC 9.0 gpm for 3/4 34.2 lpm	

V3162-100	WS1 DLFC 10.0 gpm for ¾ 38 lpm
-----------	--------------------------------

Softeners are supplied with a 20mm Push ON Hose Connection as standard the illustrated Nut and 5/8" Tube Insert are only supplied as an option.

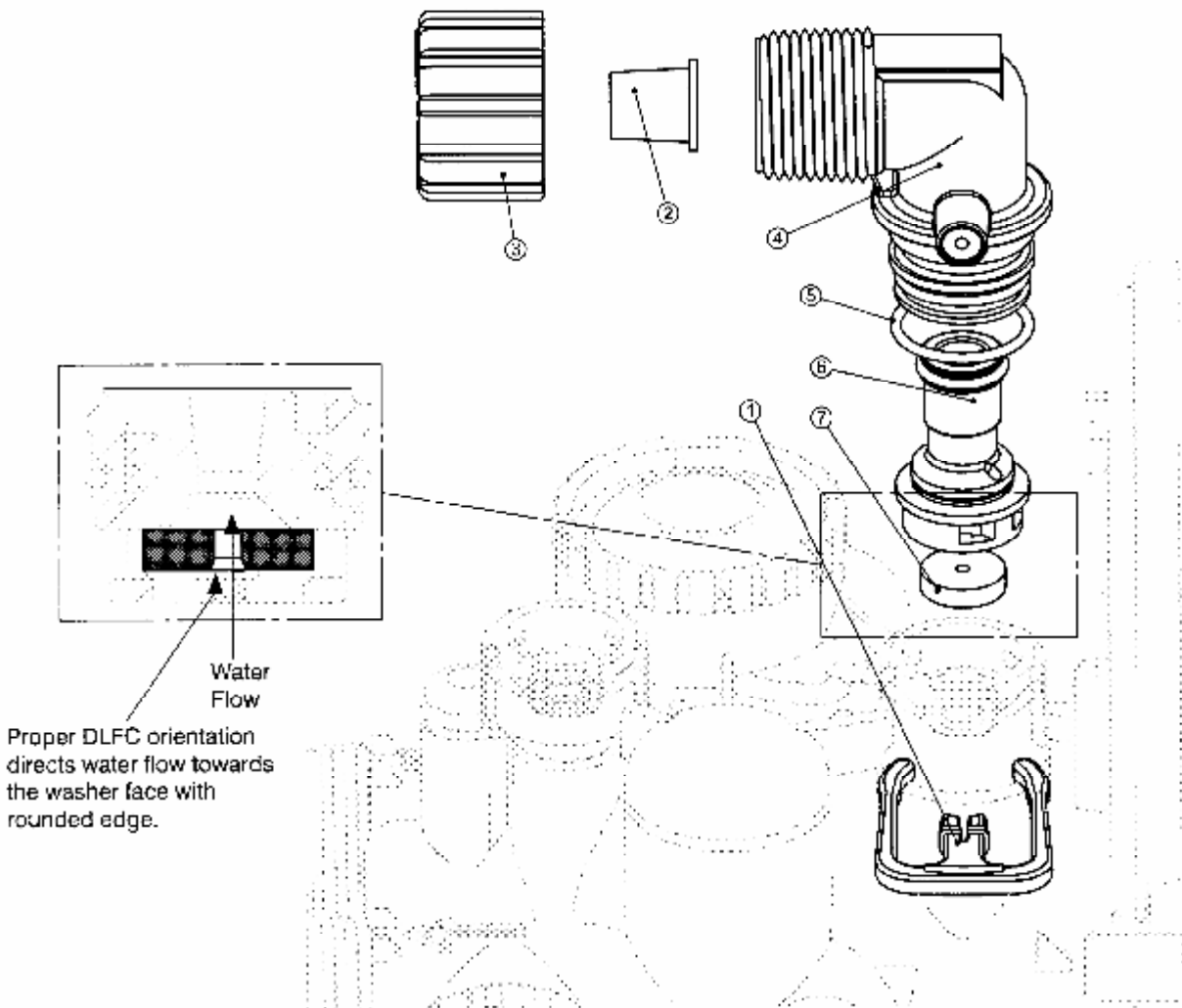

Water Meter and meter Plug

Drawing No.	Order No.	Description	Quantity
1	V3151	WS1 Nut 1: QC	1
2	V3003*	WS1 Meter ASY	1
3	V3118-01	WS1 Turbine ASY	1
4	V3105	O-ring 215	1

* Order number V3003 includes V3118-01 WS1 Turbine Assy and V3105 O-ring 215.

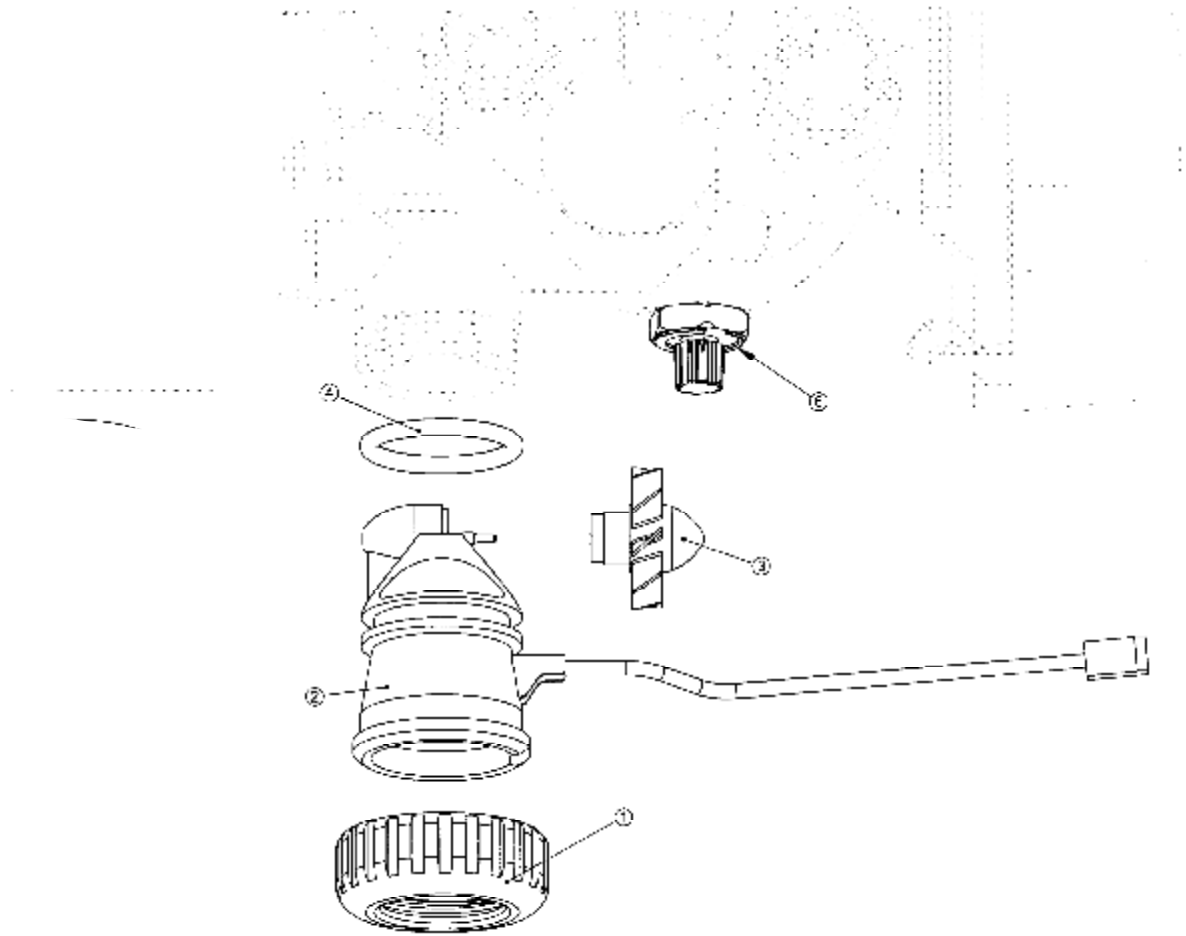

Installation Fitting Assembly

Order No: **V3007-01**

Description: **WS1 Fitting ¾" & 1" PVC Solvent 90° ASY**

Drawing No.	Order No.	Description	Quantity
1	V3151	WS1 Nut 1" Quick Connect	2
2	V3150	WS1 Split Ring	2
3	V3105	O-Ring 215	2
4	V3189	WS1 Fitting ¾ & 1 PVC Solvent 90	2

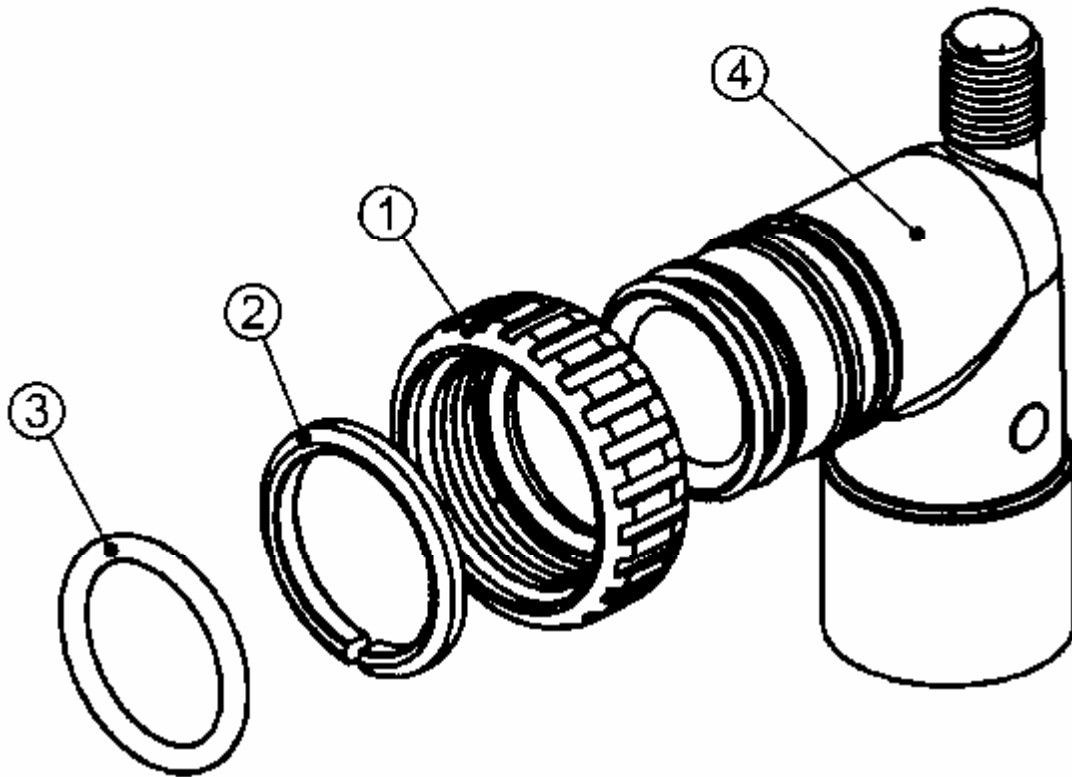

Bypass Valve

Drawing No.	Order No.	Description	Quantity
1	V3151	WS1 Nut 1" Quick Connect	2
2	V3150	WS1 Split Ring	2
3	V3105	O-ring 215	2
4	V3145	WS1 Bypass 1" Rotor	2
5	V3146	WS1 Bypass Cap	2
6	V3147	WS1 Bypass Handle	2
7	V3148	WS1 Bypass Rotor Seal Retainer	2
8	V3152	O-ring 135	2
9	V3155	O-ring 112	2

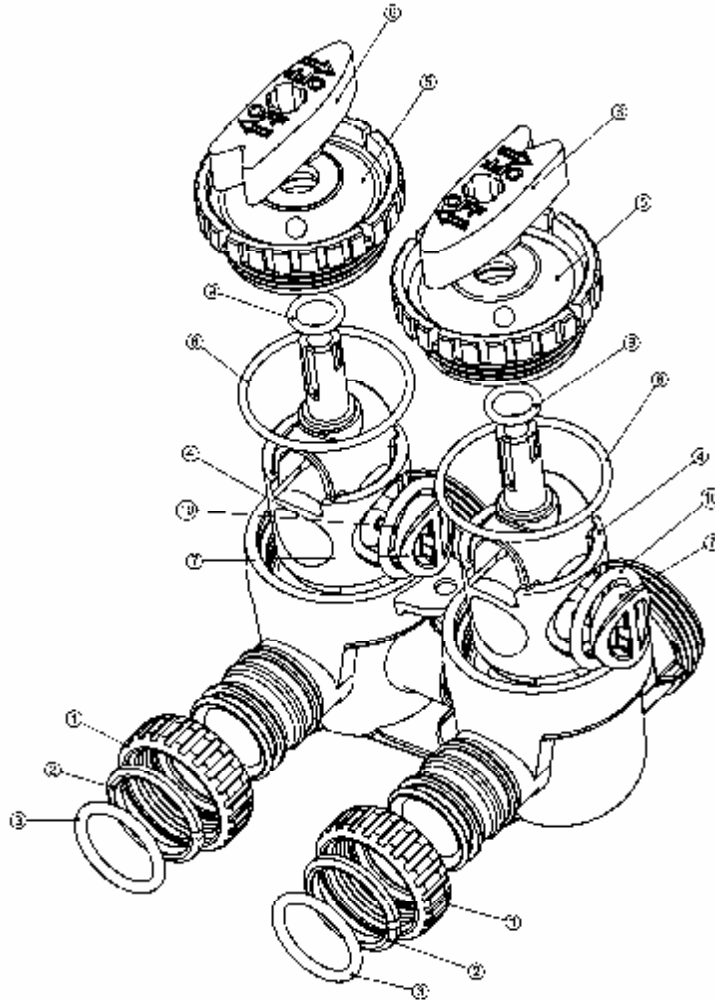

Flow Diagrams – Service and Backwash

flow diagram...service

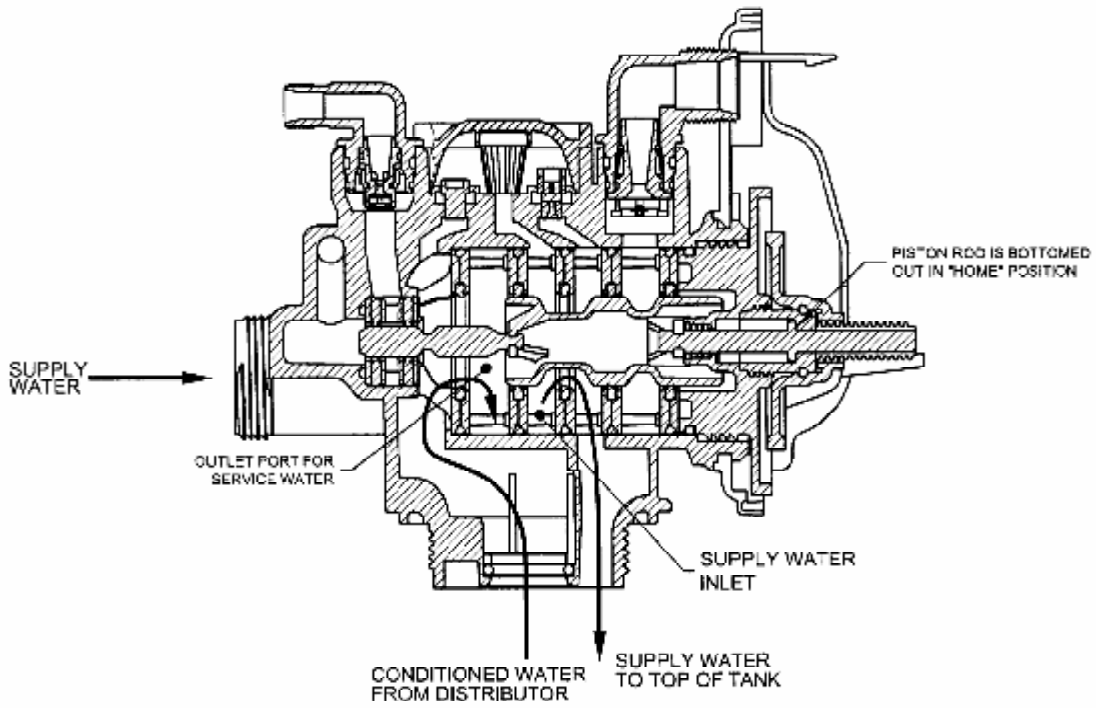

flow diagram...backwash

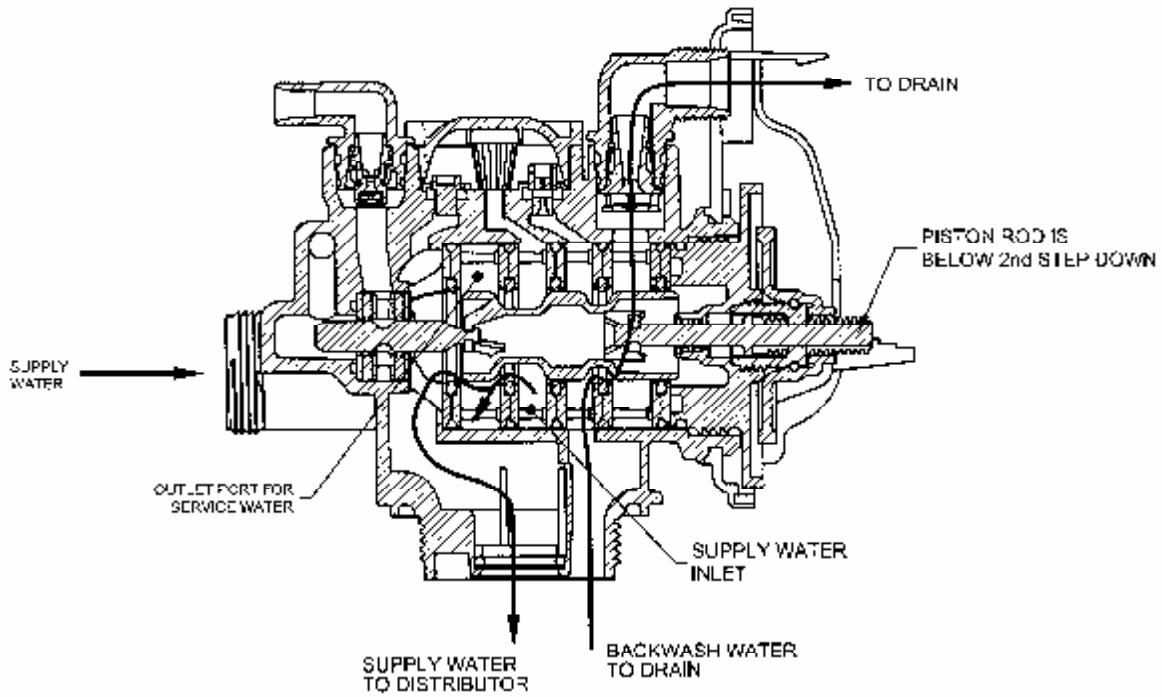

Flow Diagram – Downflow

flow diagram...downflow brine

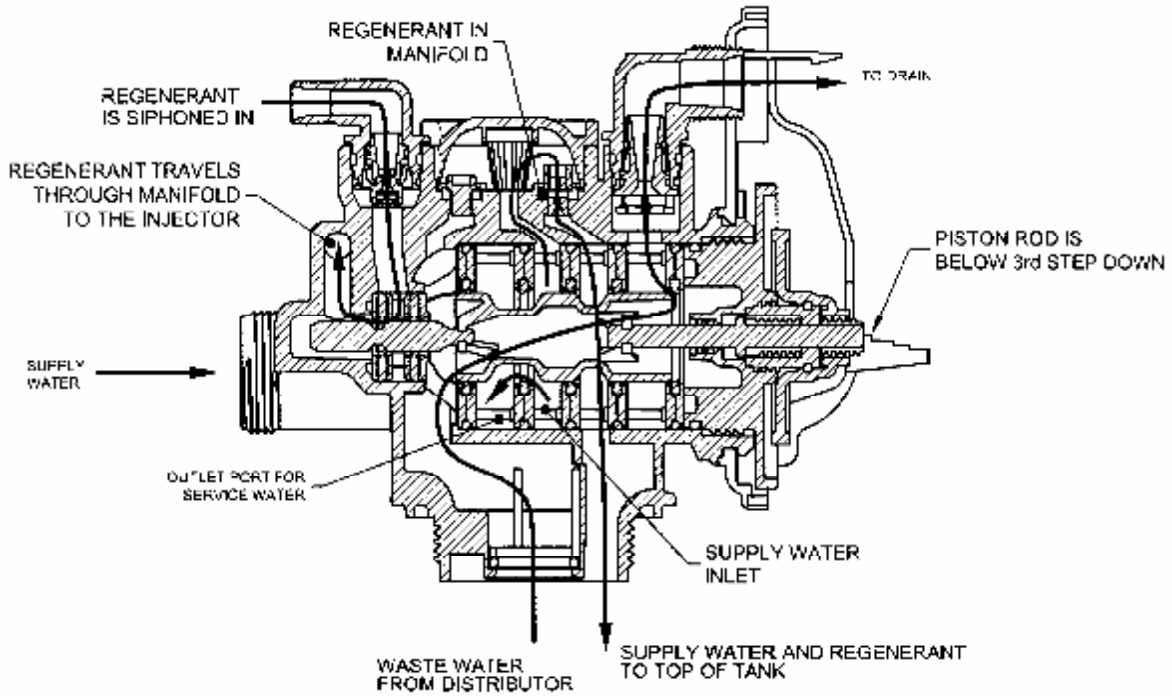

Flow Diagrams – Rinse and Fill

flow diagram...rinse

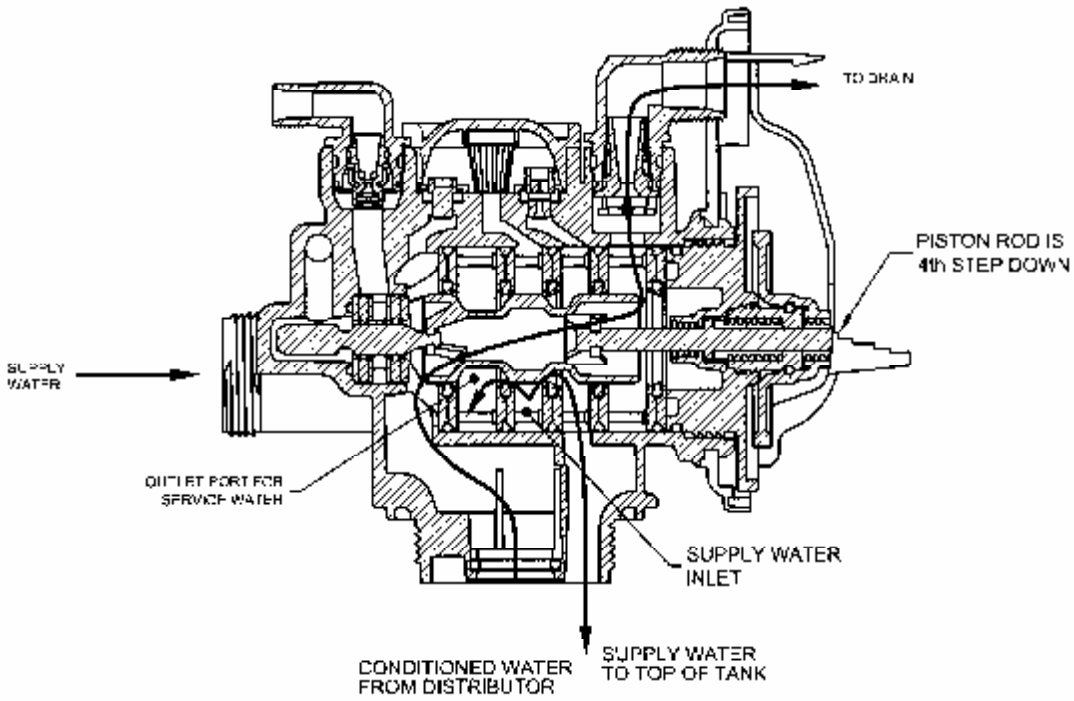

flow diagram...fill

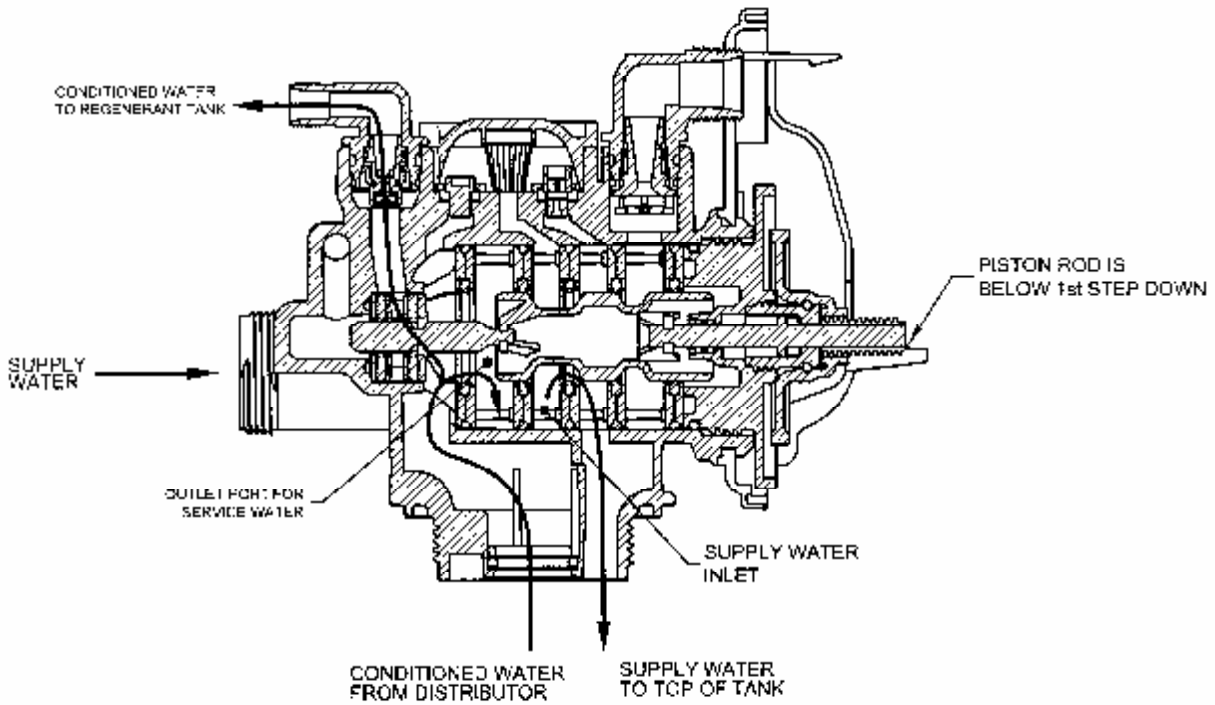

WS1 Wrench
(Order No. V3193-01)

Although no tools are necessary to assemble or disassemble the valve, the WS1 wrench (shown in various positions on the valve) may be purchased to aid in assembly or disassembly.

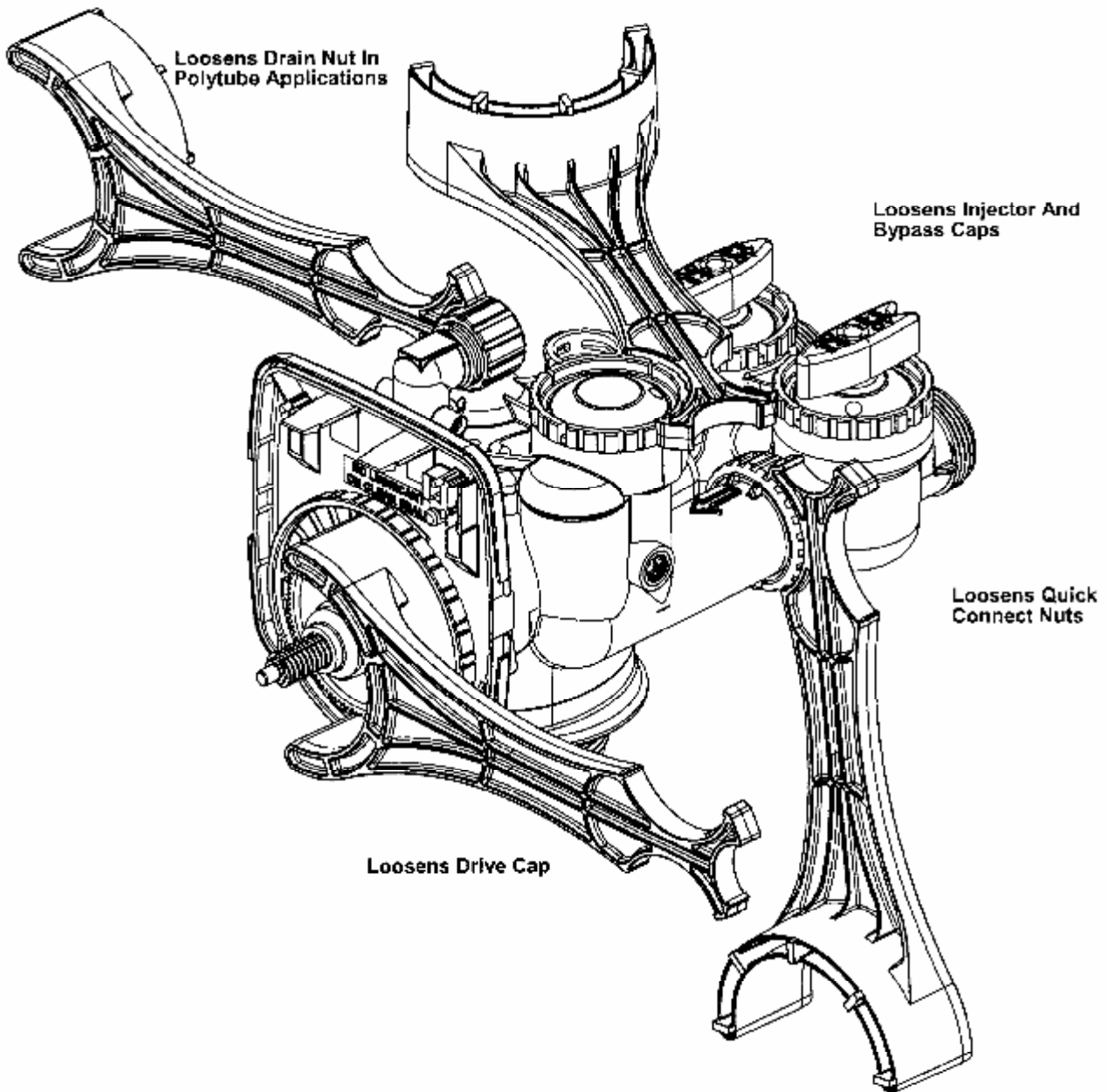

Service Instructions

Drive Assembly

Remove the valve cover to access the drive assembly.

Disconnect the power source plug (black wire) from the PC board prior to disconnecting the motor or water meter plugs from the PC board. The power source plug connects to the four-pin jack. The motor plug connects to the two-pin jack on the left-hand side of the PC board. The water meter plug (gray wire) connects to the three-pin jack on the far right-hand side of the PC board.

The PC board can be removed separately from the drive bracket but it is not recommended. Do not attempt to remove the display panel from the PC board. Handle the board by the edges. To remove the PC board from the drive bracket, unplug the power, water meter and motor plugs from the PC board. Lift the middle latch along the top of the drive bracket while pulling outward on the top of the PC board. The drive bracket has two plastic pins that fit into the holes on the lower edge of the PC board. Once the PC board is tilted about 45° from the drive bracket it can be lifted off of these pins. To reinstall the PC board, position the lower edge of the PC board so that the holes in the PC board line up with the plastic pins. Push the top of the PC board towards the valve until it snaps under the middle latch, weave the power and water meter wires into the holders and reconnect the motor, water meter and power plugs.

The drive bracket must be removed to access the drive cap assembly and pistons or the drive gear cover. It is not necessary to remove the PC board from the drive bracket to remove the drive bracket. To remove the drive bracket start by removing the plugs for the power source and the water meter. Unweave the wires from the side holders. Two tabs on the top of the drive back plate hold the drive bracket in place. Simultaneously lift the two tabs and gently ease the top of the drive bracket forward. The lower edge of the drive bracket has two notches that rest on the drive back plate. Lift up and outward on the drive bracket to disengage the notches.

To reassemble, seat the bottom of the drive bracket so the notches are engaged at the bottom of the drive back plate. Push the top of the drive bracket toward the two latches. The drive bracket may have to be lifted slightly to let the threaded piston rod pass through the hole in the drive bracket. Maintain a slight engaging force on top of the drive bracket while deflecting the bracket slightly to the left by pressing on the side of the upper right corner. This helps the drive gears mesh with the drive cap assembly. The drive bracket is properly seated when it snaps under the latches on the drive back plate. If resistance is felt before latching, then notches are not fully engaged, the piston rod is not in hold, the wires are jammed between the drive bracket and drive back plate, or the gear is not engaging the drive cap assembly.

To inspect the drive gears, the drive gear cover needs to be removed. Before trying to remove the gear cover, the drive bracket must be removed from the drive back plate. (Refer to the instructions above regarding removing the drive bracket from the drive back plate. The drive gear cover can be removed from the drive bracket without removing the motor or the PC board.) The drive gear cover is held in place on the drive bracket by three clips. The largest of the three clips is always orientated to the bottom of the drive bracket. With the PC board facing up, push in and down on the large clip on the drive gear cover. Handle the cover and the gears carefully so that the gears do not fall off of the pegs in the cover.

Replace broken or damaged drive gears. Do not lubricate any of the gears. Avoid getting any foreign matter on the reflective coating because dirt or oils may interfere with pulse counting.

The drive gear cover only fits on one way, with the large clip orientated towards the bottom. If all three clips are outside of the gear shroud on the drive bracket the drive gear cover slips easily into place.

The drive bracket does not need to be removed from the drive plate if the motor needs to be removed. To remove the motor, disconnect the power and motor plugs from the jacks on the PC board. Move the spring clip loop to the right and hold. Rotate the motor at least a ¼ turn in either direction so the wires are vertical (up & down) before gently pulling on the wire connectors to remove the motor. Pulling directly on the wires without rotating the motor may break the wires off the motor.

Replace the motor if necessary. Do not lubricate the motor or the gears. To reinstall the motor, move the spring clip loop to the right and hold. Gently turn the motor while inserting so that the gear on the motor meshes with the gears under the drive gear cover. Release the spring clip loop and continue to rotate the motor until the wires are horizontal and the motor housing engages the small plastic bulge inside the drive

bracket motor retainer. Reconnect the motor plug to the two-pronged jack on the lower left hand side of the PC board. If the motor will not easily engage with the drive gears when reinstalling, lift and slightly rotate the motor before reinserting. Reconnect the power plug.

Replace the valve cover. After completing any valve maintenance, press and hold NEXT and REGEN buttons for 3 seconds or unplug power source jack (black wire) at the circuit board and plug back in. This resets the electronics and establishes the service piston position. The display should flash all wording, then flash the soft ware version and then rest the valve to the service position.

Drive Cap Assembly, Main Piston and Regenerant Piston

The drive assembly must be removed to access the drive cap assembly. The drive cap assembly must be removed to access the piston(s). The drive cap assembly is threaded into the control valve body and seals with an o-ring. To remove the drive cap assembly use the special plastic wrench or insert a ¼" to ½" flat blade screwdriver into one of the slots around the top 2" of the drive cap assembly so it engages the notches moulded into the drive back plate around the top 2" of the piston cavity. The notches are visible through the holes. Lever the screwdriver so the drive cap assembly turns counter clockwise. Once loosened, unscrew the drive cap assembly by hand and pull straight out.

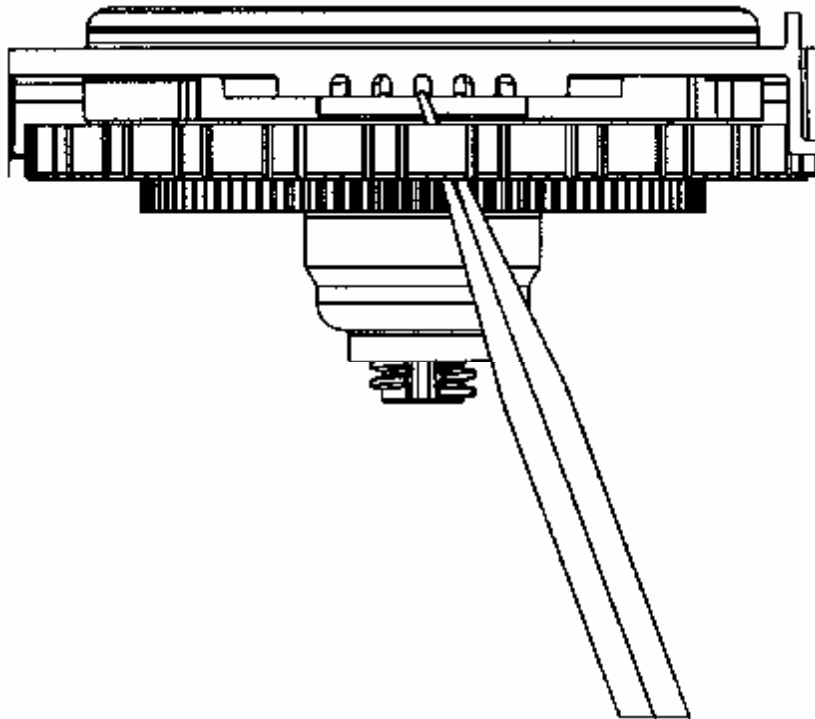

The drive cap assembly contains the drive cap, the main drive gear, drive cap spline, piston rod and various other parts that should not be disassembled in the field. The only replaceable part on the drive cap assembly is the o-ring. Attached to the drive cap assembly is the main piston (downflow) and if a regenerant is used, a regenerant piston.

The regenerant piston (the small diameter one behind the main piston) is removed from the main piston by pressing sideways and unsnapping it from its latch. Chemically clean in vinegar, or replace the regenerant piston if needed. To remove the main downflow or upflow piston fully extend the piston rod and then unsnap

the main piston from its latch by pressing on the side with the number. Chemically clean in vinegar, or replace the main piston.

Reattach the main piston to the drive cap assembly. Reattach the regenerant piston to the main piston. Do not lubricate the piston rod, main piston or regenerant piston. Lubricant will adversely affect the clear lip seals. Reinsert the drive cap assembly and piston into the spacer stack assembly and hand tighten the drive cap assembly. Continue to tighten the drive cap assembly using a screwdriver as a ratchet until the black o-ring on the spacer stack assembly is no longer visible through the drain port. Excessive force can break the notches moulded into the drive back plate. Make certain that the main drive gear still turns freely. The exact position of the piston is not important as long as the main drive gear turns freely.

Reattach the drive assembly to the control valve and connect all plugs. After completing any valve maintenance, press and hold NEXT and REGEN buttons for 3 seconds or unplug power source jack (black wire) at the circuit board and plug back in. This resets the electronics and establishes the service piston position. The display should flash all wording, then flash the software version and then reset the valve to the service position.

Spacer Stack Assembly

To access the spacer stack assembly remove the drive assembly, drive cap assembly and piston. The spacer stack assembly can be removed easily without tools by using thumb and forefinger. Inspect the black o-rings and clear lip seals for wear or damage. Replace the entire stack if necessary. Do not disassemble the stack.

The spacer stack assembly may be chemically cleaned with vinegar or wiped with a soft cloth.

The spacer stack assembly can be pushed in to the control valve body bore by hand. Since the spacer stack assembly can be compressed it is easier to use a blunt object (15.9mm (5/8") to 28.6 mm (1-1/8") in diameter) to push the centre of the assembly into the control valve body. The assembly is properly seated when at least four threads are exposed (approximately 15.89 mm (5/8"). Do not force the spacer stack assembly in. The control valve body bore interior can be lubricated with silicone to allow for easy insertion of the entire stack. Do not use silicone or any other type of lubricant on the clear lip seals or the piston.

Reattach the drive cap assembly and piston(s) and the drive assembly.

IMPORTANT NOTE:-

After completing any valve maintenance, press and hold NEXT and REGEN buttons for 3 seconds or unplug power source jack (black wire) at the circuit board and plug back in. This resets the electronics and establishes the service piston position. The display should flash all wording, then flash the software version and then reset the valve to the service position.

Injector Cap, Screen, Injector Plug and Injector

Unscrew the injector cap and lift off. Loosen cap with special wrench or pliers if necessary. Attached to the injector cap is a screen. Remove the screen and clean if fouled.

The injector can be pried out with a small screwdriver. The injector consists of a throat and a nozzle. Chemically clean the injector with vinegar. The holes can be blown out with air. Both pieces have small diameter holes that control the flow rates of water to insure that the proper concentration of regenerant is used. Sharp objects, which can score the plastic, should not be used to clean the injector. Scoring the injector or increasing the diameter of the hole could change the operating parameters of the injector. Push the injector firmly in place, replace the screen and hand tighten the injector cap.

Two holes are label "DN" and "UP". Check for compliance. See Compliance table

Compliance Table

Application	Injector and/or Plug(s)	Main Piston	Regenerant Piston	Stack	Body
WS1EI Downflow Softener or Regenerating Filter	Injector in "DN" hole.	V3011	V3174	V3005	V3001

Refill Flow Control Assembly or Refill Port Plug

To clean or replace the refill flow control, pull out the elbow-locking clip and then pull straight up on the elbow. Replace the elbow locking clip in the slot so that it is not misplaced. Twist to remove the white flow control retainer. The flow control can be removed by prying upward through the side slots of the retainer with a small flat blade screwdriver.

Chemically clean the flow control or the white flow control retainer using vinegar. Do not use a wire brush. If necessary, replace the flow control, o-ring on the flow control retainer, or the o-ring on the elbow.

Reseat the flow control so the rounded end is visible in the flow control. Reseat the white flow control retainer by pushing the retainer into the elbow until the o-ring seats. Remove locking clip, push down on elbow to reseat and insert locking clip.

Do not use Vaseline, oils, or other unacceptable lubricants on o-rings. A silicone lubricant may be used on the o-ring on the elbow or the white retainer.

Water Meter or Meter Plug

The water meter assembly is connected to the PC board by a cable. If the entire water meter assembly is to be replaced, remove the control valve cover and disconnect the power source and water meter plugs from the PC board. Unlatch the drive assembly and lean it forward. Unthread the water meter wire from the side of the drive assembly and through the drive back plate. To reinstall, rethread the water meter wire through the drive back plate and the side of the drive assembly. Reattach the drive assembly and the water meter and power plugs.

If no water meter wire is visible, then a plug is installed, not a water meter.

The water meter cable does not need to be removed from the PC board if the water meter is only being inspected and cleaned. To remove the water meter assembly, unscrew the meter cap on the left side of the control valve. Pliers may be used to unscrew the nut if necessary.

With the nut removed, a slot at the top of the water meter is visible. Twist a flat blade screwdriver in the slot between the control valve body and the meter. When the meter is part way out it is easy to remove the water meter from the housing. Once the water meter is removed from the control valve body, gently pull forward on the turbine to remove it from the shaft.

Do not use a wire brush to clean the turbine. Wipe with a clean cloth or chemically clean in vinegar. The turbine can be immersed in the vinegar. Do not immerse electronics. If the turbine is scored or damaged or the bearings on the turbine are worn, replace the turbine.

Do not lubricate the turbine shaft. The turbine shaft bearings are pre-lubricated. Do not use Vaseline, oils, or other unacceptable lubricants on the o-ring. A silicone lubricant may be used on the black o-ring.

Snap the turbine on the shaft and reinsert the water meter into the side slot. Hand tighten the nut. Do not use a pipe wrench to tighten nut.

Bypass Valve

The working parts of the bypass valve are the rotor assemblies that are contained under the bypass valve caps. Before working on the rotors, make sure the system is depressurized. Turn the red arrow shaped handles towards the centre of the bypass valve and back several times to ensure rotor is turning freely.

The nuts and caps are designed to be unscrewed or tightened by hand. if necessary a pliers can be used to unscrew the nut or cap. Do not use a pipe wrench to tighten or loosen nuts or caps. Do not place screwdriver in slots on caps and/or tap with a hammer. To access the rotor, unscrew the cap and lift the cap, rotor and handle out as one unit. Twisting the unit as you pull it out will help to remove it more easily. There are three o-rings: one under the rotor cap, one on the rotor stem and the rotor seal. Replace worn o-rings. Clean rotor. Reinstall rotor.

When reinstalling the red arrow handles be sure that:

- 1. The handle pointer are lined up with the control valve body arrows, and the rotor seal o-ring and retainer on both rotors face to the right when being viewed from the front of the control valve; or**
- 2. Arrows point toward each other in the bypass position.**

Since the handles can be pulled off, they could be accidentally reinstalled 180° from their correct orientation. To install the red arrow handles correctly, keep the handles pointed in the same direction as the arrows engraved on the control valve body while tightening the bypass valve caps.

After completing any valve maintenance, press and hold NEXT and REGEN buttons for 3 seconds or unplug power source jack (black wire) at the circuit board and plug back in. This resets the electronics and establishes the service piston position. The display should flash all wording, then flash the software version and then reset the valve to the service position.

Order No.: **V3009**
 Description: **WS1 Auxiliary Micro Switch Assembly**

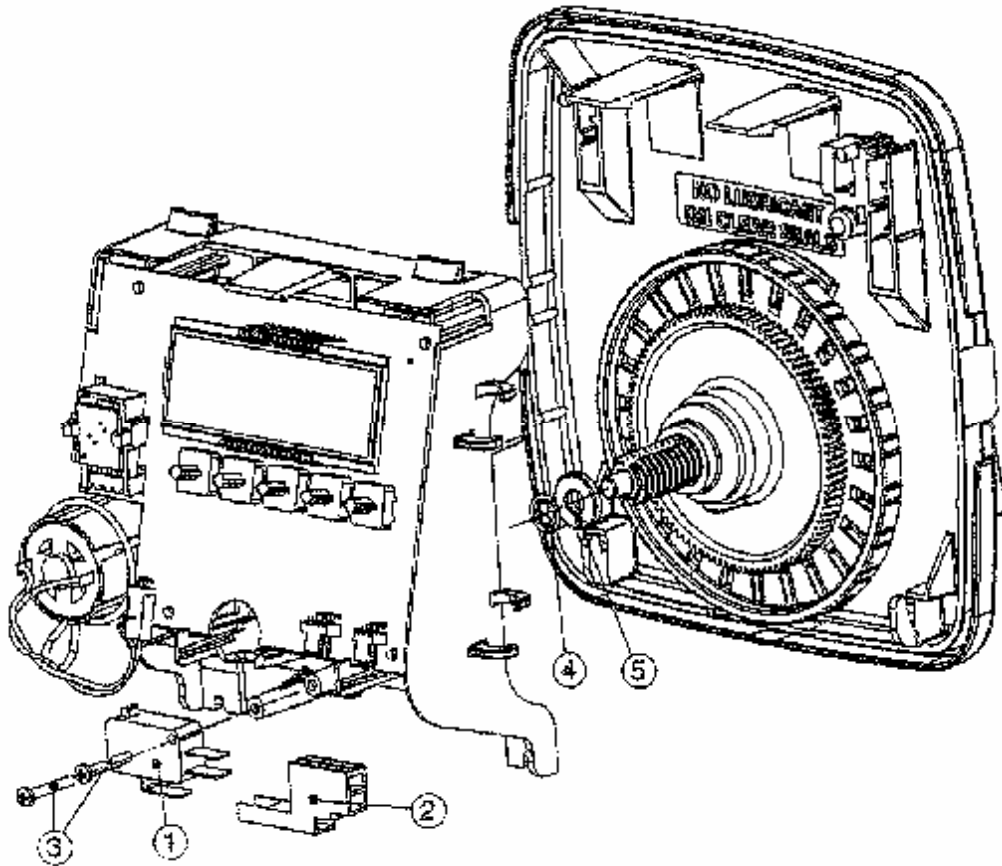

Order No.: **V3009**
 Description: **WS1 Auxiliary Microswitch Assembly**

Drawing No.	Order No.	Description	Quantity
1	V3301	WS1 MICROSWITCH	1
	V3302	WS1 MOLEX CONNECTOR	1
Not Shown	V3303	WS1 MOLEX TERMINAL	3
3	V3304	WS1 SCREWS 4/40 X 5/8	2
4	V3305	WS1 RETAINING RING SS ¼	1
5	V3306	WS1 WASHER ID 0.257 OD 0.640	1

Slip the washer and retaining ring on to the end of the piston rod. Attach the microswitch to the drive bracket using the screws. Attach the connector to the microswitch. Attach the terminals to wires and connect.

INJECTOR PERFORMANCE CURVES

BLACK, ORDER NO. V3010-1A
Metric Units

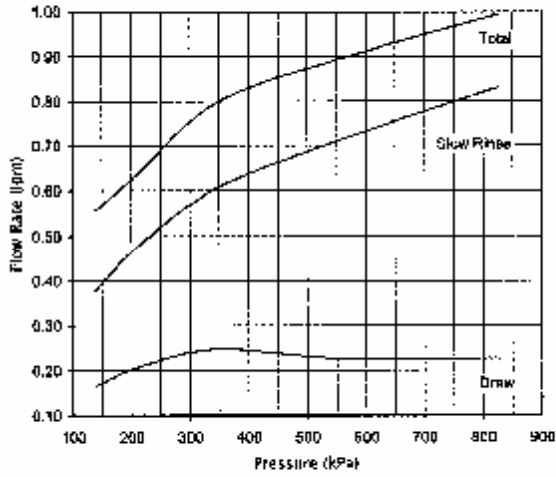

BROWN, ORDER NO. V3010-1B
Metric Units

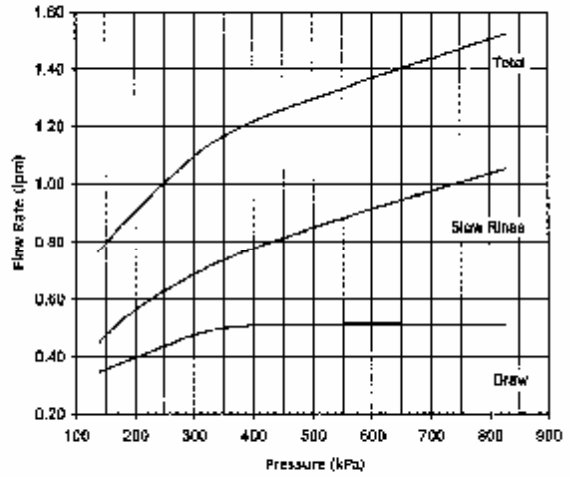

VIOLET, ORDER NO. V3010-1C
Metric Units

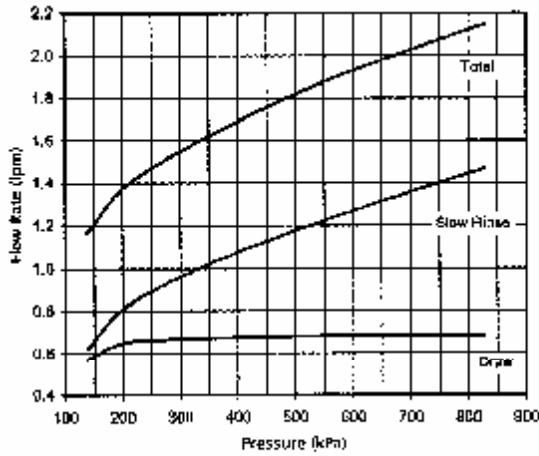

RED, ORDER NO. V3010-1D
Metric Units

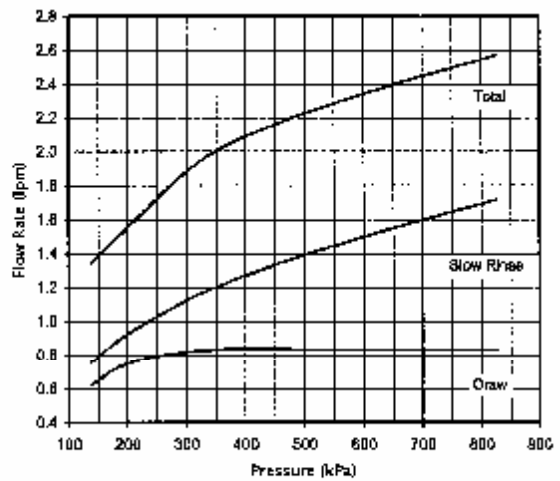

WHITE, ORDER NO. V3010-1E
Metric Units

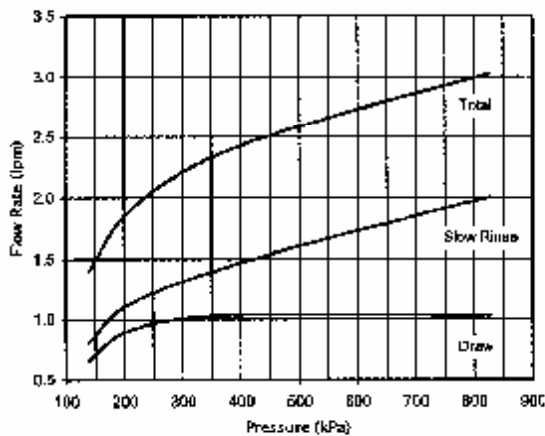

BLUE, ORDER NO. V3010-1F
Metric Units

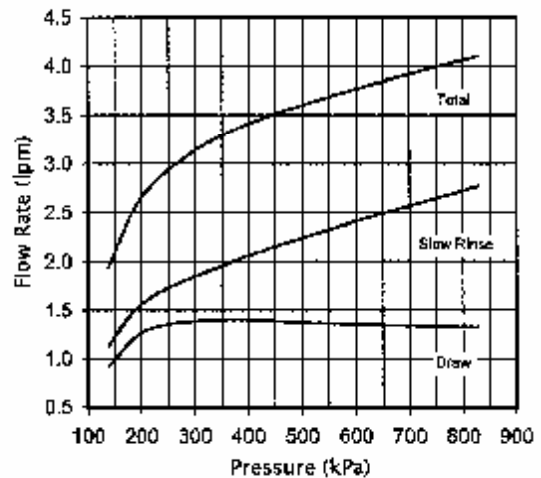

YELLOW, ORDER NO. V3010-1G
Metric Units

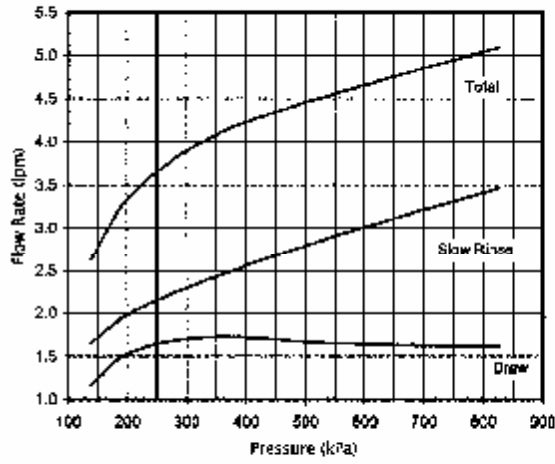

GREEN, ORDER NO. V3010-1H
Metric Units

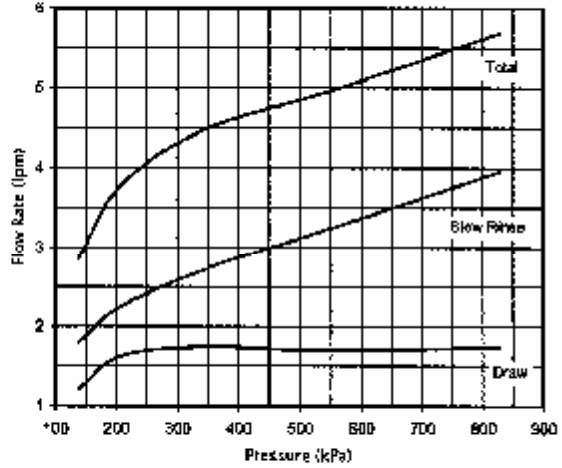

ORANGE, ORDER NO. V3010-1I
Metric Units

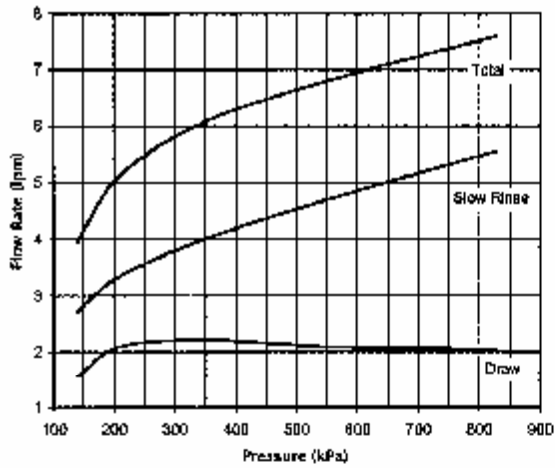

LIGHT BLUE, ORDER NO. V3010-1J
Metric Units

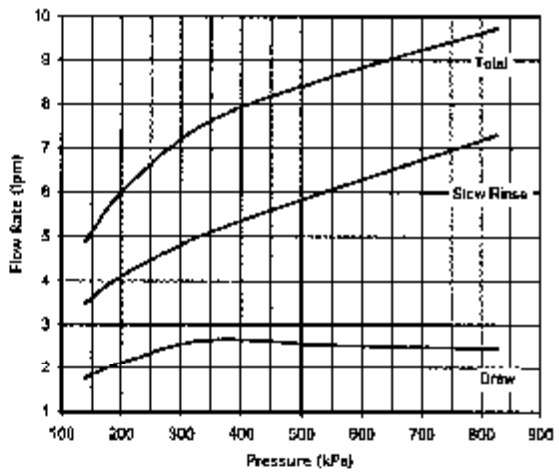

LIGHT GREEN, ORDER NO. V3010-1K
Metric Units

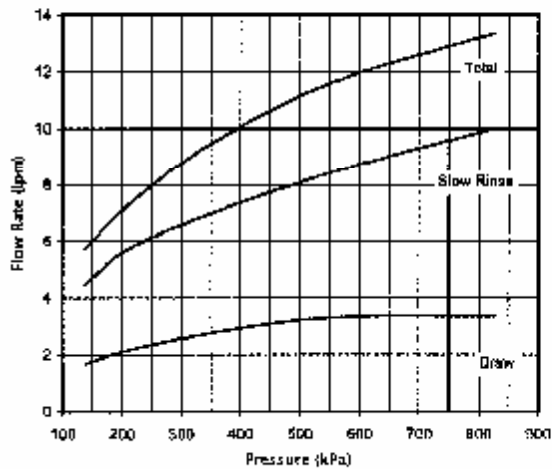

Troubleshooting

Your water conditioning system is designed and manufactured for efficient, low maintenance service. However, if problems do occur, this section provides a list of possible causes and solutions.

Alarms

The control continuously monitors itself and sends an error to the display if it detects something wrong. When the error is sensed, the display shows the letters Err with a number from 1 to 4. Refer to microprocessor troubleshooting procedures.

Refer to table 3 to help identify the cause of a problem. You can solve some problems yourself, such as low salt in the storage tank or a blown household fuse. However, some problems require installer or dealer assistance.

Caution
Service procedures that require the water pressure to be removed from the system are marked with a ! after the possible cause. To remove water pressure from the system, put the bypass valve into the shut off position and open the service line valve. Restore system water pressure when the service work is completed.

Table 3 – Troubleshooting Procedures

Problem	Cause	Solution
1. Hard water at the tap.	<ul style="list-style-type: none"> a. Low or no salt in the salt storage tank. b. Capacity setting to low to accommodate water hardness or water usage. c. Unit did not regenerate. d. Plugged injector. ! e. Air check valve prematurely closed, in brine riser pipe. 	<ul style="list-style-type: none"> a. Refill the salt storage tank and manually initiate a regeneration. Refer to the Manual Regeneration section in this manual. b. Reduce the capacity setting. Refer to the Capacity Setting section in this manual. c. Check power. d. Clean injector and screen. Refer to the Cleaning the Injector/Injector Screen in this manual. e. Replace brine riser pipe if needed. Check brine line connection for air tightness.
2. Hard water leakage during service.	<ul style="list-style-type: none"> a. Improper Regeneration. b. Internal seal problem. c. O-ring around riser tube damaged. ! 	<ul style="list-style-type: none"> a. Check that the correct salt dosage is used. Repeat regeneration. b. Contact dealer. c. Contact dealer.
3. Loss of power to the system.	<ul style="list-style-type: none"> a. Transformer unplugged. b. Fuse blown, circuit breaker open, or circuit switched off. 	<ul style="list-style-type: none"> a. Connect the power. b. Correct the electrical problem.
4. Control does not regenerate automatically.	<ul style="list-style-type: none"> a. Transformer unplugged. b. Defective control. 	<ul style="list-style-type: none"> a. Plug transformer into outlet; plug transformer cable into control. b. Contact dealer.

Table 3 – Troubleshooting Procedures - cont...

<p>6. Control does not draw brine.</p>	<p>a. Low water pressure b. Restricted drain line. c. Injector or injector screen plugged. ! d. Injector defective. ! e. Valve general malfunction f. Air check prematurely closed in brine tank</p>	<p>a. Increase water pressure. b. Remove restriction. c. Clean injector and screen, Refer to the Cleaning the Injector/Injector Screen section in this manual. d. Replace injector. Contact dealer. e. Contact dealer f. Replace or repair air check if needed. Check brine line connections.</p>
<p>7. Intermittent or irregular brine draw.</p>	<p>a. Low water pressure. b. Defective injector. !</p>	<p>a. Increase water pressure. b. Replace both injector and injector cap. Contact dealer.</p>
<p>8. Brine tank overflow.</p>	<p>a. Air leak in brine line to air check. b. Refill program setting incorrect.</p>	<p>a. Check all connections in brine line for leaks. b. Contact dealer.</p>
<p>9. System using more or less salt than estimated.</p>	<p>a. Inaccurate program setting of brine refill. b. Air check system incorrect. c. Defective brine refill operation control</p>	<p>a. Contact dealer. b. Contact dealer. c. Contact dealer.</p>
<p>10. Control backwashes at excessively low or high rate.</p>	<p>a. Incorrect backwash controller. b. Foreign matter affecting controller operation. !</p>	<p>a. Contact dealer. b. Remove backwash controller. Clean & replace.</p>
<p>11. Flowing or dripping water at drain line after regeneration.</p>	<p>a. Internal valve malfunction.</p>	<p>a. Contact dealer.</p>

Microprocessor Troubleshooting Procedures

Problem	Possible Cause	Solution
1. Timer does not display time of day.	a. AC Adapter unplugged	a. Connect power
	b. No electric power at outlet	b. Repair outlet or use working outlet
	c. Defective AC adapter	c. Replace AC adapter
	d. Defective PC board	d. Replace PC board
2. Timer does not display correct time of day.	a. Switched outlet	a. Use uninterrupted outlet
	b. Power Outage	b. Reset time of day
	c. Defective PC board	c. Replace PC board
3. No softening/filtering display when water is flowing.	a. Bypass valve in bypass position	a. Put bypass valve in service position
	b. Meter connection disconnected	b. Connect meter to PC board
	c. Restricted/stalled meter turbine	c. Remove meter and check for rotation or foreign material
	d. Defective meter	d. Replace meter
	e. Defective PC board	e. Replace PC board
4. Control valve regenerates at wrong time of day.	a. power outages	a. Reset control valve to correct time of day
	b. Time of day not set correctly	b. Reset to correct time of day
	c. Time of regeneration incorrect	c. Reset regeneration time
	d. Control valve set at "on O" (immediate regeneration)	d. Check control valve set-up procedure regeneration time option.
5. Err followed by code number Error Code 1001 – Unable to recognize start of regeneration Error Code 1002-Unexpected stall Error Code 1003-Motor ran too long, timed out trying to reach next cycle position Error 1004 – Motor ran too long, timed out trying to reach home position If other Error Codes display contact the factory.	a. Control valve has just been serviced	a. Press NEXT and REGEN for 3 seconds or unplug power source jack (black wire) and plug back in to reset control valve.
	b. Foreign matter is lodged in control valve	b. Check piston and spacer stack assembly for foreign matter
	c. high drive forces on piston	c. Replace piston(s) & spacer stack assembly
	d. Control valve piston not in home position	c. Press NEXT and RGEN for 3 seconds or unplug power source jack (black wire) and plug back in to reset control valve
	e. Motor not inserted fully to engage pinion, motor wires broken or disconnected, motor failure	e. Check motor and wiring. Replace motor if necessary
	f. Drive gear label dirty or damaged, missing or broken gear	f. Replace or clean drive gear
	g. Drive bracket incorrectly aligned to back plate	g. Reseat drive bracket properly
	h. PC board is damaged or defective	h. Replace PC board
	i. PC board incorrectly aligned to drive bracket.	i. Ensure PC board is correctly snapped on to drive bracket.
6. Control valve stalled in regeneration	a. Motor not operating	a. Replace motor
	b. No electric power at outlet	b. Repair outlet or use working outlet
	c. Broken drive gear or drive cap assembly	c. Replace AC adapter
	d. Defective PC board	d. Replace PC board
	e. Broken drive gear or drive cap assembly	e. Replace drive gear or drive cap assembly
	f. Broken piston retainer	f. Replace piston retainer
	g. Broken main or regenerant piston	g. Replace main or regenerant piston
7. Control valve does not regenerate automatically when REGEN button is depressed and held	a. AC adapter unplugged	a. Connect AC adapter
	b. No electric power at outlet	b. Repair outlet or use working outlet
	c. Broken drive gear or drive cap assembly	c. Replace drive gear or drive cap assembly
	d. Defective PC board	d. Replace PC board
8. Control valve does not Regenerate automatically but does when REGEN button is depressed	a. Bypass valve in bypass position	a. Put bypass valve in normal operation position.
	b. Meter connection disconnected	b. Connect meter to PC board
	c. Restricted/stalled meter turbine	c. Remove meter and check for rotation or foreign matter
	d. Defective meter	d. Replace meter
	e. Defective PC board	e. Replace PC board
	f. Set-up error	f. Check control valve set-up procedure

9. Time of day flashes on and off	a. Power has been out more than two hours, the AC adapter was unplugged and then plugged back into the wall outlet, the AC adapter plug was unplugged and then plugged back into the board or the NEXT and REGEN buttons were pressed to reset the valve.	a. Reset the time of day
-----------------------------------	---	--------------------------

Glossary of Terms

Alarms

Display errors alert you to operating conditions requiring attention. The display shows the type of error. Refer to the **Alarms** section in this manual for additional information.

Backwash

An upward flow of water, which expands the resin bed to remove foreign particles.

Brine

The salt solution which regenerates the conditioner's resin bed.

Brine Draw

The process of drawing the brine solution from the salt storage tank into the resin tank.

Fast Rinse (Purge)

A flow of water through the resin bed which propels any remaining brine solution out of the resin tank to the drain.

Hardness

A common quality of water containing dissolved calcium, magnesium and other elements. Water hardness is usually expressed milligrams per litre as calcium carbonate equivalent.

Manual Regeneration

Forces the control to regenerate by pressing the REGEN button.

Regeneration

Includes the backwash, brine draw, and fresh water rinse steps necessary to prepare the resin bed for conditioning after exhaustion.

Regeneration Indicator

The display arrow which indicates the regeneration cycle status.

Resin Bed

The supply of synthetic organic exchange material used in water conditioners. This material is subject to degradation and will need to be renewed. Resin replacement normally varies between 3 to 7 years.