

Techspan Extruder Welder
model "micro"
Operating Instructions

Article No. / Machine type	:	DX283, Micro
Machine No.	:
Required mains power	:	230 V / 50 - 60 Hz
Overall power consumption	:	1500 W

These operating instructions, including all texts, drawings and appendices contained herein, are copyrighted by DOHLE Extrusionstechnik GmbH. Any reproduction or duplication and/or forwarding to third parties of these operating instructions or any part(s) thereof is prohibited without our express written permission.

Please carefully read and understand these operating instructions before starting or operating your Micro hand welding extruder (Micro HWE) as we are not in any way liable for damages caused by or associated with improper use. Should you consider modifying your Micro HWE, please consult us in advance as any modifications made without our approval render its warranty invalid.

Use the Micro HWE only for its normal intended use.

Ensure availability of these operating instructions at all times to the personnel operating the Micro HWE.

For service or parts please contact:

TECHSPANGROUP

Australia:
P. 1-800 148 791
F. 1-800 148 799
E. info@plasticweldingtools.com.au

New Zealand:
P. 0800 603 603
F. (09) 827 6596
E. info@plasticweldingtools.co.nz

Attention:

Do not operate the Micro HWE from mains sources with impedances greater than $Z_{max.} = 0.264 + j0.165$. Contact your local utilities company to get impedance data of your mains network if it is not available.

Safety Information :

Operate the Micro HWE only when powered from a mains network protected by a RCCB (residual current operated circuit breaker) or an isolation transformer, as specified in German Electricians Association specification VDE 0 100 § 55 .

Do not permit the Micro HWE to become damp or contact water.

When operating the Micro HWE, observe all local and national safety regulations in their currently valid versions.

Observe all accident prevention regulations in their currently valid versions and applicable technical regulations for safe and technically proper work procedures.

Observe all applicable parts of Council Directive 92 / 57 / EEC of 24 June 1992.

Information Concerning Use:

DOHLE Micro hand welding extruders are designed in accordance with state-of-the-art technology and current safety regulations.

However if they are used improperly, safety hazards for users or third parties and/or damage to machines and other property may result.

Use the Micro HWE only when in technically sound condition and only in accordance with its intended application purpose as well as these operating instructions.

The manufacturer / supplier cannot be held responsible for damages resulting from or associated with users' non-observance of these operating instructions.

Any use of the Micro HWE other than its intended application purpose is prohibited without the prior approval of the manufacturer / supplier.

Maintenance or other work on the electrical systems of the Micro HWE must be carried out by qualified electricians only in accordance with accepted technical practice and regulations.

The Micro HWE may be used by qualified technicians only following thorough training on the Micro HWE.

Extruders are not intended for use by persons (including children) with reduced physical, sensory oder mental capabilities or persons with insufficient experience and/or knowledge unless they are supervised by a person responsible for their safety or have been instructed in the safe use of the Micro HWE.

Do not permit children to play with the Micro HWE!!

Information Regarding Particular Safety Hazards:

MICRO hand welding extruders may only be held and manipulated by their hand grips intended for those purposes.

Bare metal parts of the Micro HWE can reach temperatures of up to 350 °C, therefore do **not** touch them.

Warning: Heat may be conducted to flammable materials which are not immediately visible and ignite them.

Safety zone:

Do not point the hot air jet of the Micro HWE towards people, animals or heat-sensitive objects. Maintain a downstream safety clearance of 2 m to people, animals and heat-sensitive objects.

Do not point the hot air jet towards any one spot for an extended period of time.

Operation :

Do not operate the Micro HWE without air supply.

Be certain that the extruder (DX283), the supply line package (DX285), and the E box (DX284) are properly connected before starting the Micro HWE.

Working overhead:

When working above head level, wear appropriate safety equipment (helmet, goggles etc.).

Electric Safety :

Power the Micro HWE only from an easily accessible, grounded (earthed) socket outlet.

Before connecting the Micro HWE to a mains outlet, check the voltage of the outlet to be sure that it is the same as the nominal voltage given on the nameplate of the Micro HWE.

Operate the Micro HWE only when protected by a RCCB (residual current operated circuit breaker) or an isolation transformer, as specified in German Electricians Association specification VDE 0 100 § 55 .

Extension Cords:

When using extension cords, be sure that they have at least the following minimum conductive cross-sectional areas:

Cord lengths up to 18 m: 2.5 mm²

Cord lengths up to 50 m: 4.0 mm² .

Any extension cords used must be approved by the national electric safety authority for the site of use and marked accordingly.

Do not operate the Micro HWE if:

- its power cable or plug are damaged (in this case arrange for repair, by manufacturer or qualified electricians only), or
- any of its safety-related components are damaged, or
- foreign materials or liquids have entered the Micro HWE, or
- the Micro HWE has been damaged or operates differently than usual.

Never spray the Micro HWE with water (this can cause short circuiting).

Do not use the Micro HWE **in explosive** or flammable areas.

Operating the Micro HWE with insufficient care can cause fires.

Setting down the Micro HWE:

When setting the Micro HWE down, always do so on its support surfaces provided for this purpose to avoid undesired movement or tipping over.

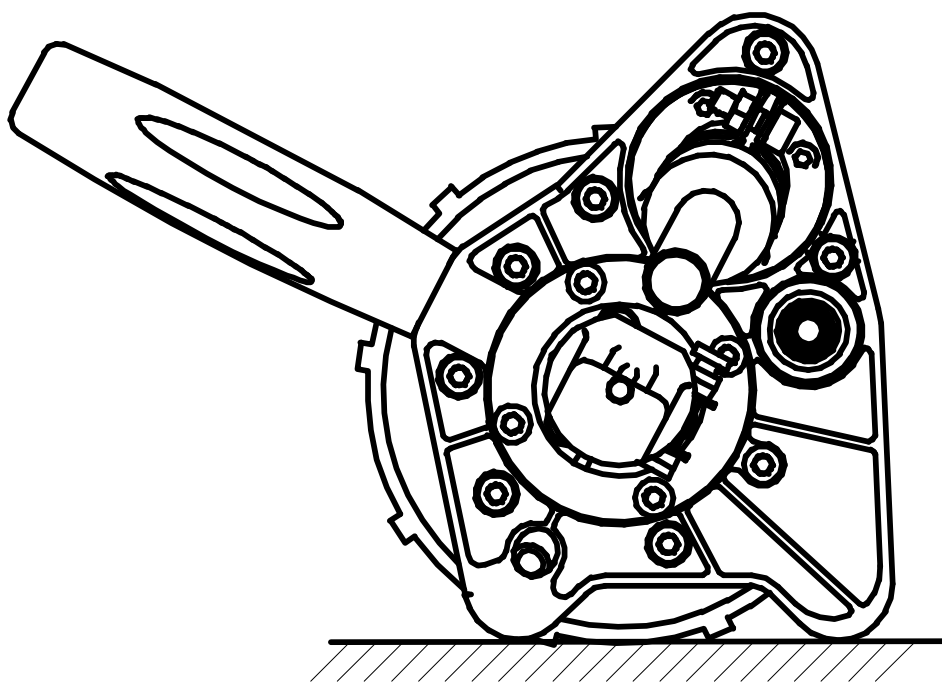

Starting Up the Micro HWE

General Information:

Observe all safety-related instructions and information given in these operating instructions.

In addition observe all accident prevention regulations and national safety regulations valid in the country in which the Micro HWE is operated.

Post-Delivery Assembly of Micro HWE

Micro hand welding extruders require only minimum assembly following shipping to your plant.

Connect the E Box (air and electric feed-in lines) to the extruder.

Screw the included hand grip (if required) onto the extruder.

Welding Shoes

Use the two welding shoe blanks included in the scope of delivery to fabricate the welding shoes required for the welding seams you intend to make.

Note: When doing this, observe DVS 2207 Guidelines Part 4 (DVS = Deutscher Verband für Schweißen = German Welding Society).

If you prefer, we can supply two ready-to-use welding shoes instead of the blanks. In this case please specify with your order the desired seam dimensions and thickness of the panels to be welded together.

Installation of Welding Shoe

Welding shoe is only to be changed by manual power. Do not use any tools in order to avoid damage of the welding shoe.

Caution: Very hot! Can cause burns! – use appropriate gloves.

1) Installation

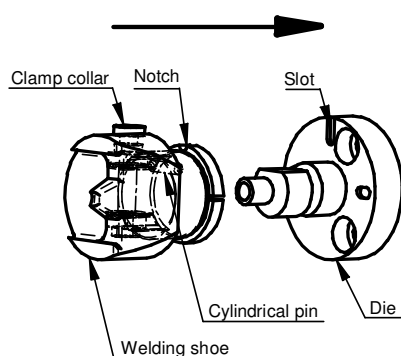

To install the welding shoe, place it on the die such that its notch is even with the vertical slot in the die.

2) Working Position

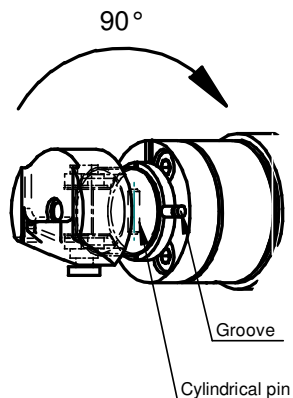

To bring the welding shoe into its working position, turn it 90° clockwise. The notch in the welding shoe should now be even with the groove in the die. The cylindrical pin retains the components to prevent decoupling due to melt pressure. Maintaining this position, tighten and lock the clamp collar.

3) Removal

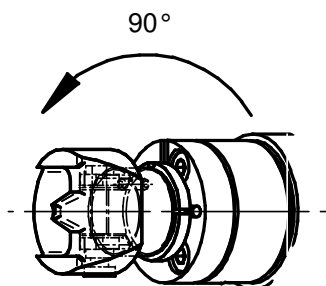

Loosen the clamp collar and turn the welding shoe 90° counter-clockwise. The welding shoe is now no longer arrested and can be removed.

Available Air Nozzles for Micro HWE

The standard air nozzle supplied with the Micro HWE is a tubular nozzle, Article No. D-1148.

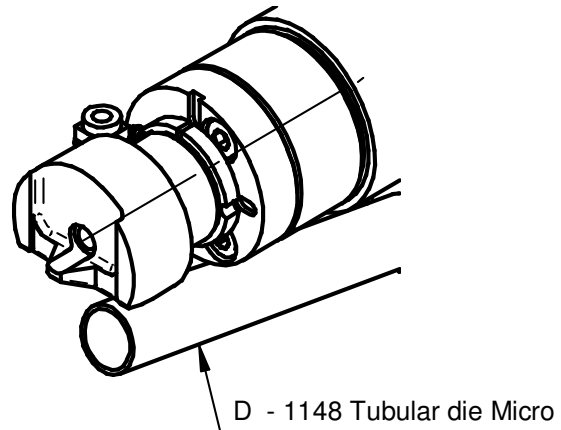

An optional nozzle version is also available, a tubular nozzle with a pivoting tacking nozzle, Article No. D-1340.

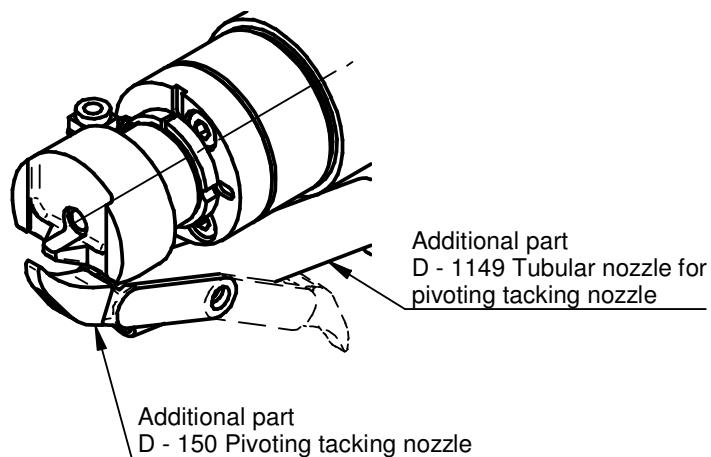

D - 1340 Tubular nozzle with pivoting tacking nozzle,
complete unit

Starting Up the Micro HWE

Observe all safety-related instructions and information given in these operating instructions.

Do not operate the Micro HWE without air supply. Operating the Micro HWE without air supply will damage it.

Before plugging your Micro HWE into the mains socket, please check to ensure that:

- the "HEAT" switch for the heater units is in the "OFF" position,
- the air supply is properly connected,
- all electrical connections are properly connected and
- the drive motor switch is in the "OFF" position.

All DOHLE hand welding extruders are equipped with a patented melt temperature sensor (a melt-immersed thermocouple located between the screw and the die) and cold-start lockout protection.

Now plug the power plug of the Micro HWE into a suitable mains socket (230 V, 16 A).

Operate the Micro HWE only from easily accessible grounded (earthed) socket outlets. Air supply starts automatically when the power plug is plugged into the mains socket. Now flip the "HEAT" switch on the E Box front panel to the "ON" position .

The Micro HWE now heats up to the temperature setpoints most recently selected.

To change temperature setpoints, please refer to the section of these operating instructions entitled "Changing Temperature Setpoints" (p. 13).

Do not leave the Micro HWE unattended when in operation.

Controller Panel – Control

Housing

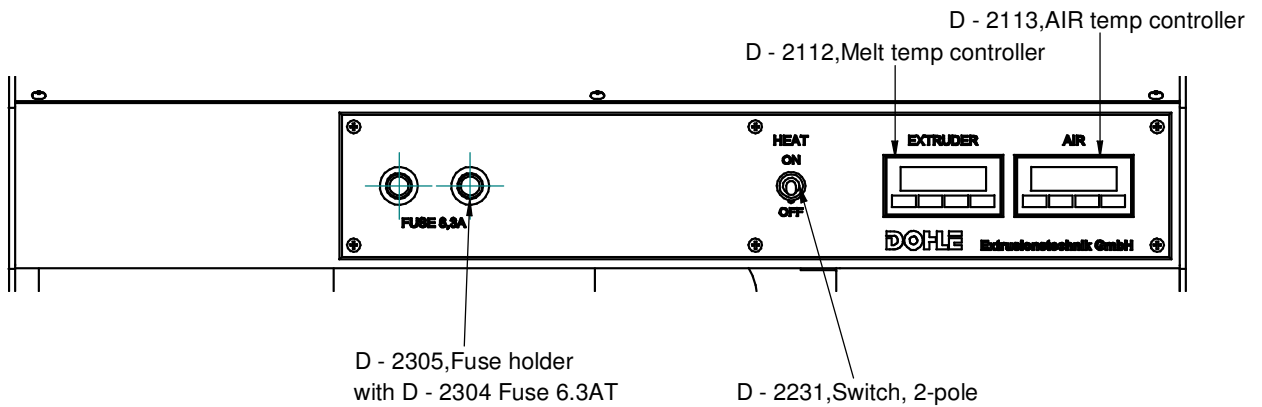

Display and Operating Controls of E Box Front Panel

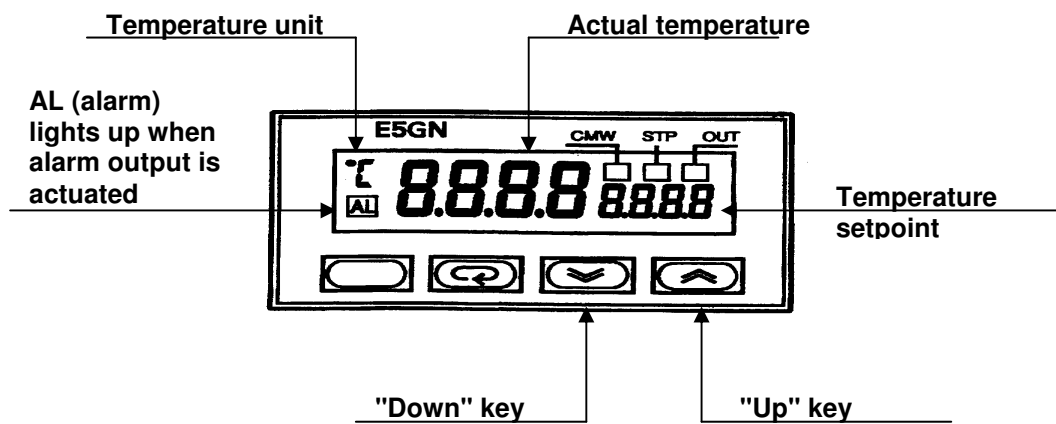

Entering Controller Setpoints

All controllers can be changed in their setpoints only and incorporate an electronic lockout function preventing false entries.

Changing Temperature Setpoints:

The controller simultaneously displays the actual temperature and the temperature setpoint.

To change the temperature setpoint, proceed as follows:

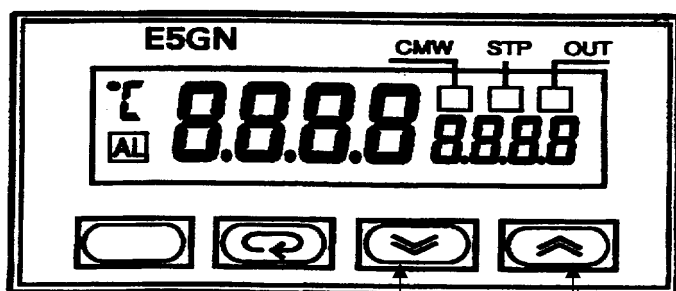
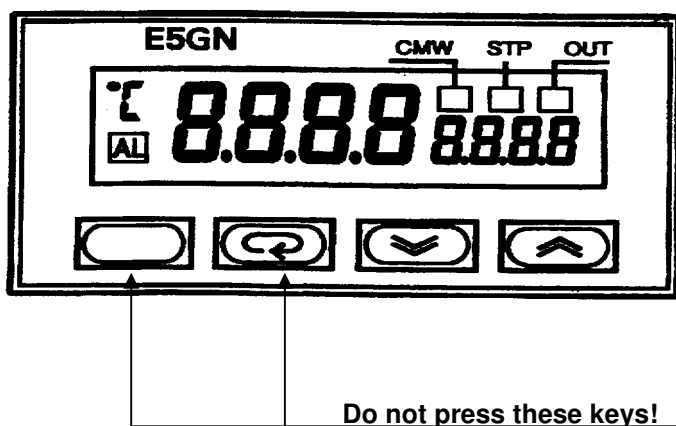

"Down" key

Each time this key is pressed, the setpoint goes down. If the key is held down continuously, the setpoint goes down continuously.

"Up" key

Each time this key is pressed, the setpoint goes up. If the key is held down continuously, the setpoint goes up continuously.

Processable Resins:

The Micro HWE can be used to process the following thermoplastic resins:

PE, PP, PVC-U, PVDF, ECTFE. Special equipment: PVC-C

Observe all instructions and information provided by the resin manufacturers.

Change in Resin Processed

When you change the resin processed, you must first remove all of the resin last processed from the Micro HWE. To do this, first heat up the Micro HWE to the selected operating temperature and remove the welding shoe.

Warning: Take appropriate measures to prevent burns when working on the hot Micro HWE

Next, **purge the Micro HWE** for approx. 20 minutes **with the new resin**. Then install the replacement die which must be either new or last used with the resin now to be processed.

When interrupting welding work

Do not leave the Micro HWE unattended.

Maintain the air supply to the Micro HWE.

Warning: when processing PVC or PVDF, do not interrupt operation for more than 3 minutes.

Should interruption occur for over 3 minutes or when you are stopping welding work with either of these resins, remove them from the barrel by purging for approx. 5 minutes with PE or PP.

Shutting Down the Micro HWE

Set the Micro HWE down on the integrated support surfaces provided for this purpose.

Flip the "HEAT" switch on the E Box front panel to the "OFF" position. Approx. 2 minutes later, unplug the power plug out of the socket outlet.

After usage, always clean the nozzles and the welding shoe (refer to page 9 mounting welding shoe).

Warning: Burns can be suffered when touching bare metal parts, even 15 minutes after the Micro HWE has been shut down.

Do not apply water or any other materials to accelerate cooling.

Servicing

Unplug the power plug of the Micro HWE from the socket outlet before doing servicing work of any kind on the Micro HWE.

Servicing may be done by qualified electricians only!

Observe all safety-relevant instructions and information given in these operating instructions!

Maintenance:

The extruder and air compressor drives are brushless motors and therefore essentially maintenance free.

Thrust Bearing / Extruder Screw

Every 250 operating hours, the extruder screw should be cleaned and the thrust bearing replaced (Attention: replace with original DOHLE thrust bearing only, which is filled with high-temperature grease).

Trouble Shooting

<u>Malfunction</u>	Error No.
Drive motor does not start.	01,02,04,05,06,07,08,09,10,11
Drive motor shuts down.	03,04,05,06,07,08,09
Extruder remains cold.	01,02,04,05,06,07,08,09,12,14
Hot air remains cold.	01,02,05,07,08,09,11,12,14,16
Hot air temperature does not attain setpoint.	10
Melt temperature does not attain setpoint.	10
Extruder does not propel melt from die.	10

Controller Malfunctions

<u>Display on Controller</u>	<u>Error No.</u>
Display does not light up.	01,06,07
Display: S . e r r	12
Display is not stable.	14
Wrong incremental direction on display	15

Error No.	Possible cause	Resolution
01	No power supply	Connect power supply
02	Incorrect mains voltage	Have mains supply checked by qualified specialist
03	Extension cord gets hot	Check conductive cross section Unroll cable drum completely
04	Defective melt temp thermocouple	Replace thermocouple
05	Defective air temp thermocouple	Replace thermocouple
06	Defective melt temp controller	Replace controller
07	Defective air temp controller	Replace controller
08	"HEAT" switch on front panel in "OFF" position	Switch to "ON"
09	Defect(s) in cable connections	Have checked by qualified specialist
10	Preheating period too short	Allow extruder to heat up.
11	No supply of outside air	Connect outside air intake line
12	Thermocouple damage monitor signal	Replace thermocouple
13	Unsuccessful attempt to change blocked parameter	Have parameter deblocked, by qualified specialist only
14	Thermocouple malfunction or loose connections	Check thermocouple Check connections
15	Improperly connected sensor, + and - interchanged	Check connections

DX 283.1 Extruder

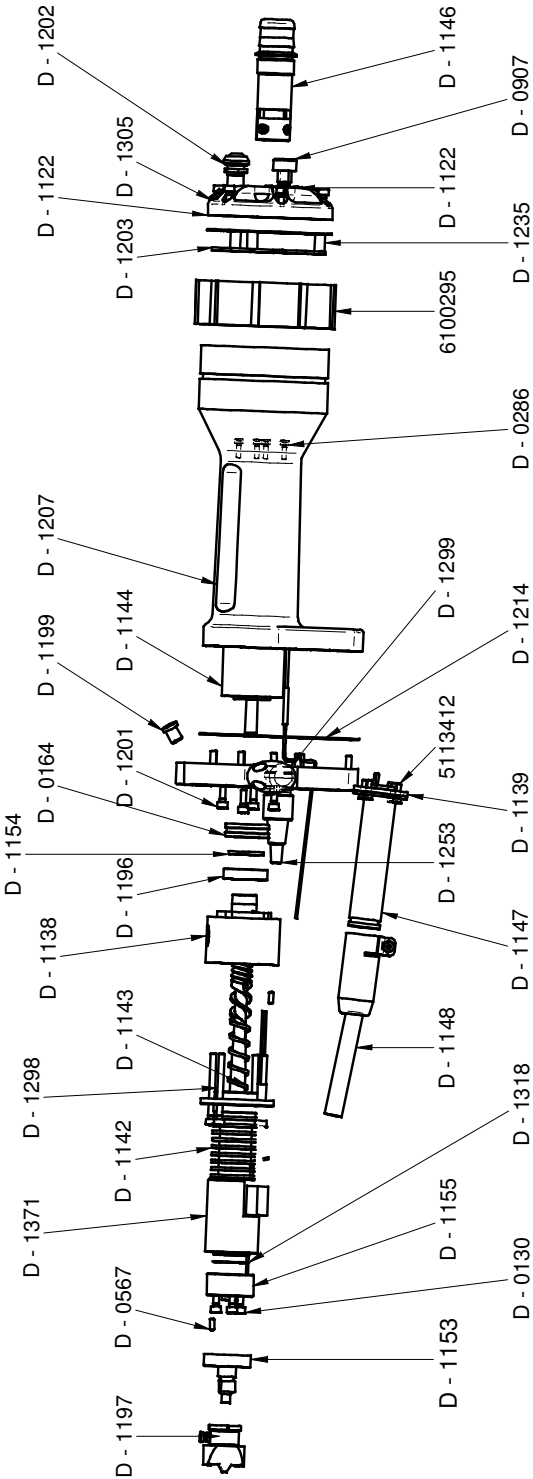

Parts list DX283.1 Extruder

Article No	Description	Quantity
5113127	Mica insulation tube 19x89.5	1
5113412	Heating element 33C Micro	1
6100295	Rubber ring seal	1
D - 0129	Socket head cap screw M4x10 DIN912	3
D - 0130	Socket head cap screw M4x16 DIN912	17
D - 0164	Axial deep-groove ball bearing 51103	1
D - 0286	Socket head cap screw M3x10 DIN912	8
D - 0567	Cylindrical pin 3x8 DIN7	2
D - 0907	22K potentiometer	1
D - 1122	Cover Micro	1
D - 1138	Resin intake unit Micro	1
D - 1139	Heating-element seal Micro	1
D - 1142	Extruder barrel Micro	1
D - 1143	Extruder screw Micro	1
D - 1144	Drive motor Micro	1
D - 1146	Connector Micro	1
D - 1147	Hot air infeed tube Micro	1
D - 1148	Tubular nozzle Micro	1
D - 1150	Pivoting tacking nozzle	1
D - 1153	Die Micro	1
D - 1154	Spacer ring Micro	1
D - 1155	Melt temp thermocouple Micro	1
D - 1156	Air temp thermocouple Micro	1
D - 1163	Clamp collar 18/9	1
D - 1181	Welding shoe Micro V8	1
D - 1195	SOFTLINE hand grip	1
D - 1196	Deep groove ball bearing 61903 2Z	1
D - 1197	Cylindrical pin 2.5x10 DIN7	1
D - 1199	Headed press-fit bush 5x12 DIN172A	1
D - 1201	Socket head cap screw M4x12 DIN912	4
D - 1202	Push switch on/off IP67	1
D - 1203	Motor control unit Micro	1
D - 1206	Head plate Micro	1
D - 1207	Housing Micro	1
D - 1214	Head-plate gasket	1
D - 1235	Spacer bolt 3.6x7x12	3
D - 1253	Cable plug-in connector Micro	1
D - 1298	Socket head cap screw M4x45 DIN912	4
D - 1299	Flange socket Micro	1
D - 1302	Potentiometer scale Micro	1
D - 1305	on-off adhesive label Micro	1
D - 1307	Cover gasket Micro	1
D - 1318	Thermocouple gasket Micro	1
D - 1371	Mica heating band Micro	1
D - 1390	Spacer washer Micro	1

DX 283.2 E-BOX

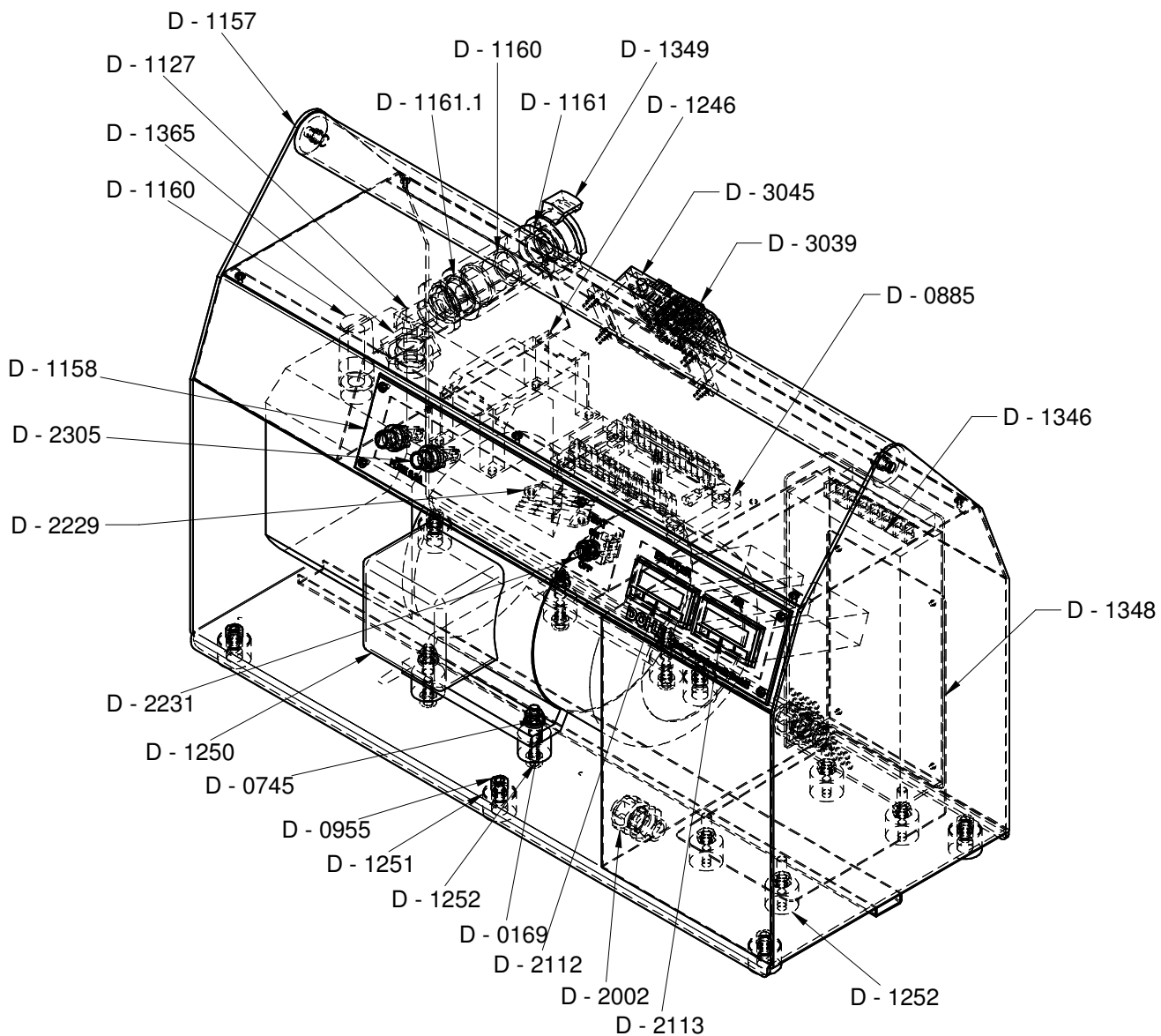

Parts list DX283.2 E-BOX

Article No.	Description	Quantity
D - 0169	Washer 6.4 VZ	4
D - 0745	Nut M6 DIN934	8
D - 0864	Round-head sheet-metal screw 2.9x6.5 DIN 7981	12
D - 0885	Main board II	1
D - 0955	Socket head cap screw M6x8 DIN912	10
D - 1127	Elbow a-a 3/8"	1
D - 1157	Station Micro	1
D - 1158	Front panel Micro	1
D - 1160	Sound absorber G1/2	2
D - 1161	Sound absorber housing Micro	1
D - 1161.1	Sound absorber housing Micro	1
D - 1246	Mains input filter	1
D - 1250	Compressor CB10	1
D - 1251	Rubber pad 20x15xM6i	6
D - 1252	Rubber pad 20x15xM6ixM6a	8
D - 1346	Power supply unit Micro	1
D - 1348	Retaining panel for power supply unit Micro	1
D - 1349	GEKA coupling 1/2", outside threading	1
D - 1365	Reducer 1/2"- 3/8"	1
D - 2002	Plastic cable gland PG9	2
D - 2112	Melt temp controller	1
D - 2113	AIR temp controller	1
D - 2229	Triac 25A	2
D - 2231	Switch, 2-pole	1
D - 2305	Fuse holder	2
D - 3039	Socket insert Micro	1
D - 3041	Contact socket 0.5mm ²	4
D - 3042	Contact socket 1mm ²	6
D - 3045	Connector housing CHI 10	1

DX 283.3 Supply Line Package

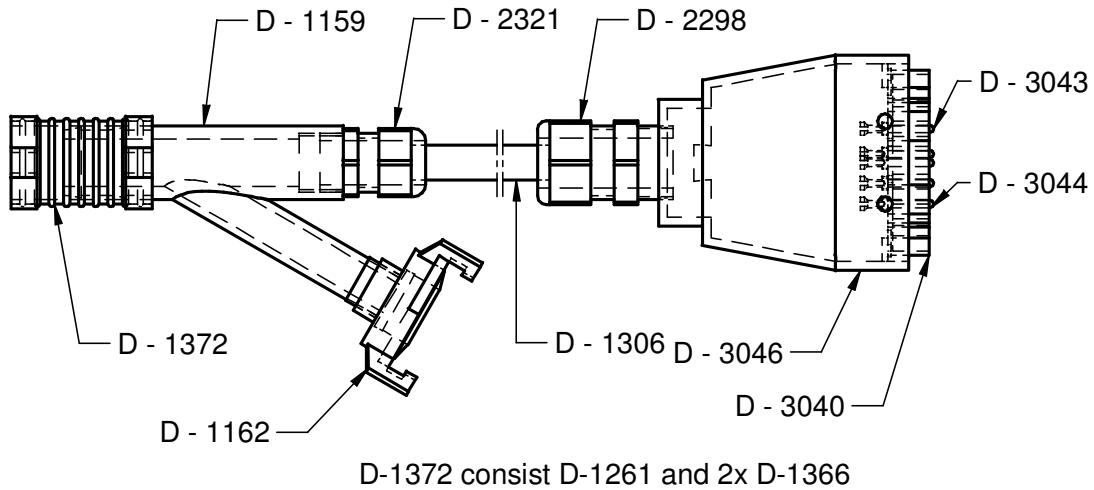

Article No.	Description	Quantity
D - 1159	Y junction Micro	1
D - 1162	GEKA coupling 3/8"	1
D - 1306	HELUKABEL HK-So Micro	1
D - 1372	Miniflex PU PG21 Micro	1
D - 2298	Cable gland M25x1.5	1
D - 2321	Cable gland M20x1.5	1
D - 3040	Male insert Micro	1
D - 3043	Contact pin 0.5mm ²	4
D - 3044	Contact pin 1mm ²	6
D - 3046	Plug connector housing Micro	1

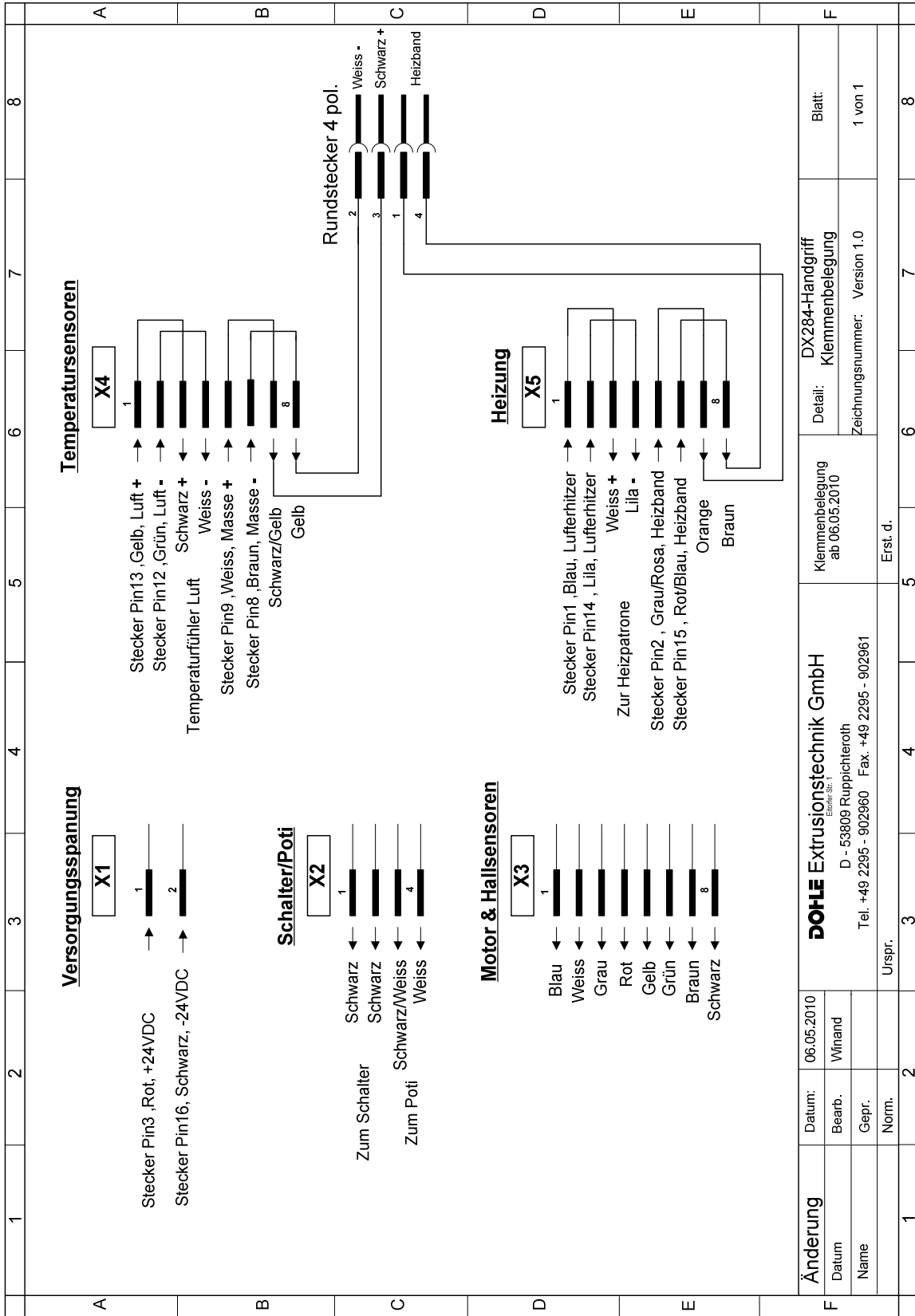

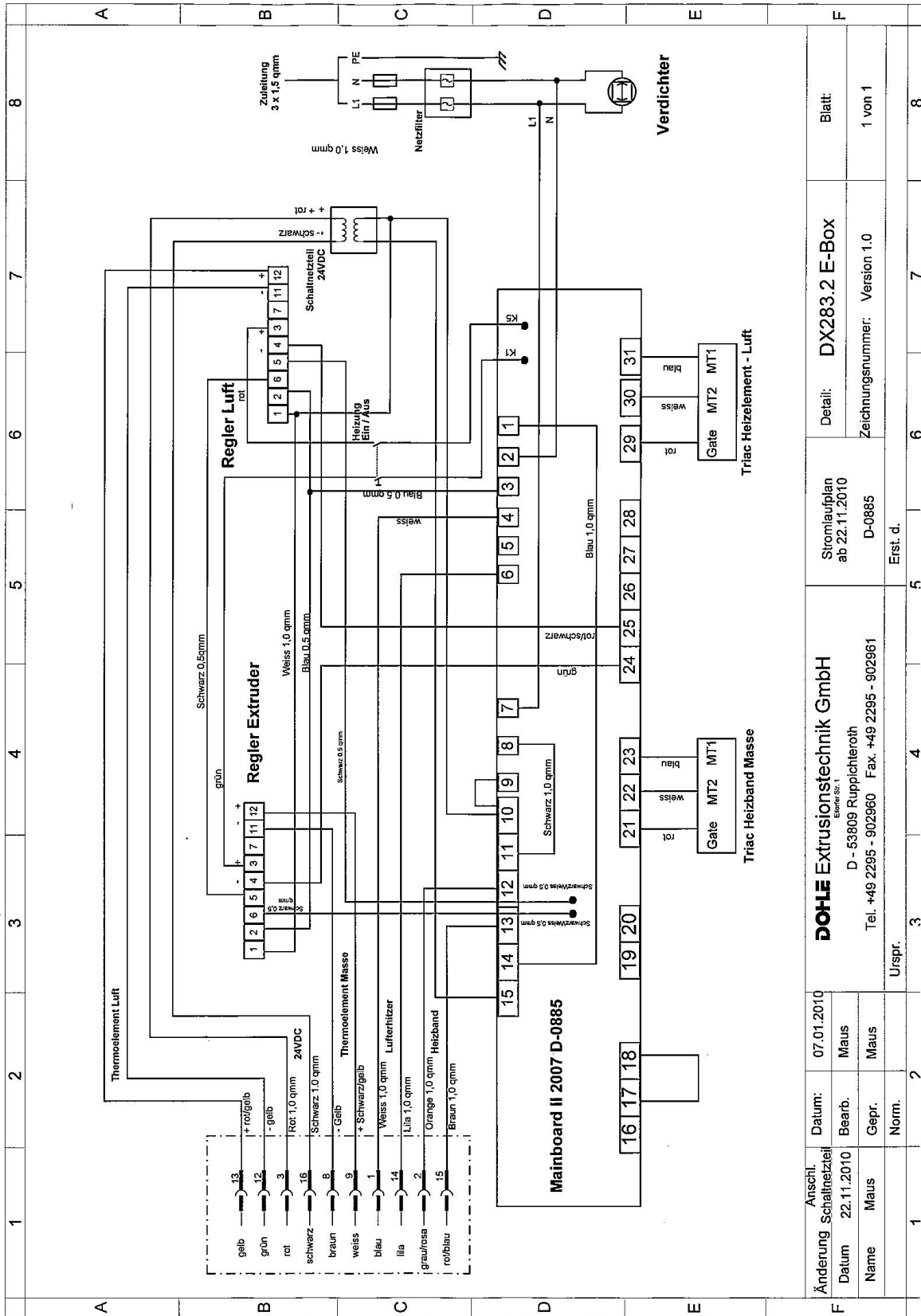

Änderung	Schaltrelais	Datum:	07.01.2010
Datum	22.11.2010	Bearb.	Maus
Name	Maus	Gepr.	Maus
		Norm.	
Anschl.		Datum:	
Urspr.		07.01.2010	
1		2	
3		4	
5		6	
7		8	
9		10	
11		12	
13		14	
15		16	
17		18	
19		20	
21		22	
23		24	
25		26	
27		28	
29		30	
31			
3		4	
5		6	
7		8	
9		10	
11		12	
13		14	
15		16	
17		18	
19		20	
21		22	
23		24	
25		26	
27		28	
29		30	
31			
3		4	
5		6	
7		8	
9		10	
11		12	
13		14	
15		16	
17		18	
19		20	
21		22	
23		24	
25		26	
27		28	
29		30	
31			
3		4	
5		6	
7		8	
9		10	
11		12	
13		14	
15		16	
17		18	
19		20	
21		22	
23		24	
25		26	
27		28	
29		30	
31			
3		4	
5		6	
7		8	
9		10	
11		12	
13		14	
15		16	
17		18	
19		20	
21		22	
23		24	
25		26	
27		28	
29		30	
31			
3		4	
5		6	
7		8	
9		10	
11		12	
13		14	
15		16	
17		18	
19		20	
21		22	
23		24	
25		26	
27		28	
29		30	
31			
3		4	
5		6	
7		8	
9		10	
11		12	
13		14	
15		16	
17		18	
19		20	
21		22	
23		24	
25		26	
27		28	
29		30	
31			
3		4	
5		6	
7		8	
9		10	
11		12	
13		14	
15		16	
17		18	
19		20	
21		22	
23		24	
25		26	
27		28	
29		30	
31			
3		4	
5		6	
7		8	
9		10	
11		12	
13		14	
15		16	
17		18	
19		20	
21		22	
23		24	
25		26	
27		28	
29		30	
31			
3		4	
5		6	
7		8	
9		10	
11		12	
13		14	
15		16	
17		18	
19		20	
21		22	
23		24	
25		26	
27		28	
29		30	
31			
3		4	
5		6	
7		8	
9		10	
11		12	
13		14	
15		16	
17		18	
19		20	
21		22	
23		24	
25		26	
27		28	
29		30	
31			
3		4	
5		6	
7		8	
9		10	
11		12	
13		14	
15		16	
17		18	
19		20	
21		22	
23		24	
25		26	
27		28	
29		30	
31			
3		4	
5		6	
7		8	
9		10	
11		12	
13		14	
15		16	
17		18	
19		20	
21		22	
23		24	
25		26	
27		28	
29		30	
31			
3		4	
5		6	
7		8	
9		10	
11		12	
13		14	
15		16	
17		18	
19		20	
21		22	
23		24	
25		26	
27		28	
29		30	
31			
3		4	
5		6	
7		8	
9		10	
11		12	
13		14	
15		16	
17		18	
19		20	
21		22	
23		24	
25		26	
27		28	
29		30	
31			
3		4	
5		6	
7		8	
9		10	
11		12	
13		14	
15		16	
17		18	
19		20	
21		22	
23		24	
25		26	
27		28	
29		30	
31			
3		4	
5		6	
7		8	
9		10	
11		12	
13		14	
15		16	
17		18	
19		20	
21		22	
23		24	
25		26	
27		28	
29		30	
31			
3		4	
5		6	
7		8	
9		10	
11		12	
13		14	
15		16	
17		18	
19		20	
21		22	
23		24	
25		26	
27		28	
29		30	
31			
3		4	
5		6	
7		8	
9		10	
11		12	
13		14	
15		16	
17		18	
19		20	
21		22	
23		24	
25		26	
27		28	
29		30	
31			
3		4	
5		6	
7		8	
9		10	
11		12	
13		14	
15		16	
17		18	
19		20	
21		22	
23		24	
25		26	
27		28	
29		30	
31			
3		4	
5		6	
7		8	
9		10	
11		12	
13		14	
15		16	
17		18	
19		20	
21		22	
23		24	
25		26	
27		28	
29		30	
31			
3		4	
5		6	
7		8	
9		10	
11		12	
13		14	
15		16	
17		18	
19		20	
21		22	
23		24	
25		26	
27		28	
29		30	
31			
3		4	
5		6	
7		8	
9		10	
11		12	
13		14	
15		16	
17		18	
19		20	
21		22	
23		24	
25		26	
27		28	
29		30	
31			
3		4	
5		6	
7		8	
9		10	
11		12	
13		14	
15		16	
17		18	
19		20	
21		22	
23		24	
25		26	
27		28	
29		30	
31			
3		4	
5		6	
7		8	
9		10	
11		12	
13		14	
15		16	
17		18	
19		20	
21		22	
23		24	
25		26	
27		28	
29		30	
31			
3		4	
5		6	
7		8	
9		10	
11		12	
13		14	
15		16	
17		18	
19		20	
21		22	
23		24	
25		26	
27		28	
29		30	
31			
3		4	
5		6	
7		8	
9		10	
11		12	
13		1	

Available Welding Shoes MICRO

fillet weld

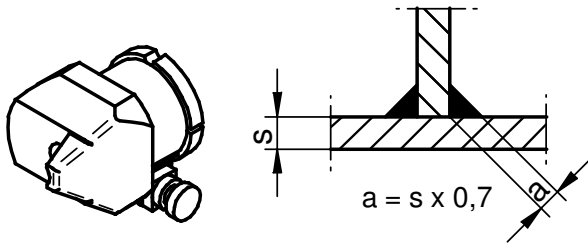

Panel thickness (s)	Article No.
3-4	D-1175
5-6	D-1176
8	D-1177
10	D-1178

V butt weld

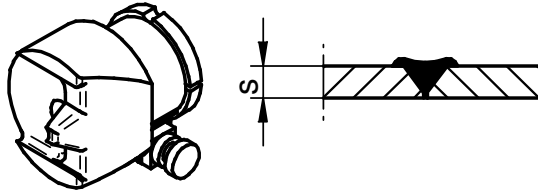

Panel thickness (s)	Article No.
3-4	D-1179
5-6	D-1180
8	D-1181

Round welding shoe

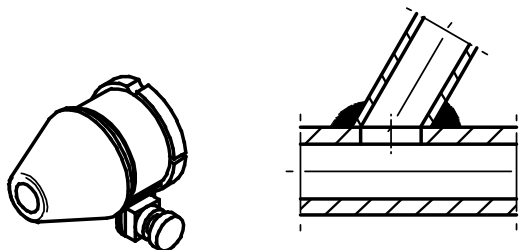

	Article No.
Ø 7	D-1183
Ø 9	D-1184