



# ***UHF BAND TRUE DIVERSITY WIRELESS MICROPHONE SYSTEM***



# **Operating Instructions**

Distributed by Altronic Distributors Pty. Ltd. Perth. Western Australia.

Phone: 1300 780 999 Fax: 1300 790 999

Internet: [www.altronic.com.au](http://www.altronic.com.au)

## **REDBACK® C 8870F UHF Band Diversity Wireless Mic System**

Congratulations on purchasing a REDBACK PLL Synthesized True Diversity Wireless Microphone system. The PLL synthesized true diversity wireless microphone system operates on UHF frequency band between 520-550MHz, with 16 selectable channels. Please read this instruction manual completely before operating the system. These instructions cover the transmitters, plus receiver model C 8870F.

Please read this instruction manual carefully before operating the system. This manual covers the function and operation of the wireless microphone system - transmitter and receiver C 8870F.

### **FEATURES:**

- Provides flexible and professional performance for stages, stadiums, places of worship, and professional sound installations.
- Operates on UHF frequency band range 520-550MHz with synthesized control
- PLL (Phase Locked Loop) synthesized wireless microphone system with 16 selectable frequencies, making it easy to choose interference free channels.
- Auto-Scan technology for easy and fast channel set-up.
- True Diversity with two antennas to ensure the highest reception quality.
- Super high sensitivity, extremely low noise transmission and reception.
- Excellent reception system ensures super high sensitivity.
- Units are supplied with SMT assembled PCB modules ensuring high reliability, and easy serviceability.
- High signal-noise ratio, high sensitivity and wide dynamic range.
- High dynamic range handheld microphone for all vocal applications.
- Lapel microphone that minimises static pickup resulting in very low noise.

### **Receiver Features:**

- 12V-18V d.c. power supply (supplied)
- Easy rotary switch selection of frequencies all hidden from users view.
- 1/2 19" size case with power and RF indicators. Rack ears available for mounting one or two systems into 19" rack equipment.
- Removable aerials making the unit suitable for portable or fixed installations. Aerials are fitted with BNC connectors.
- Includes in-built power supply for C 8842 antenna booster.

### **FCC STATEMENT:**

This device complies with part 15 of the FCC rules. Operation is subject to the following two conditions:

1. This device may not cause harmful interference and;
2. This device must accept any interference received, including interference that may cause undesired operation.

### **IMPORTANT:**

To comply with the FCC RF exposure requirements, no change to the antenna or the device is permitted. Any change to the antenna or the device could result in the device exceeding the RF exposure requirements and void user's authority to operate the device.

**Note:**The changes or modifications not expressly approved by the party responsible for compliance could void the user's authority to operate the equipment.

### **SAFETY PRECAUTIONS:**

- Do not spill liquid on the appliance and do not drop it on a hard surface.
- Do not place the appliance near heat sources such as radiators, stoves, amplifiers, or other electrical equipment.
- Do not expose it to direct sunlight, extremely dirty or dusty environments, excessive moisture or humidity, and significant vibration.
- Use good quality batteries, matching brand and model.
- Remove the battery from the transmitter if the appliance will not be used for a long period. Doing so will avoid any damage that may result from a defective leaking battery.
- Do not throw used batteries into a fire. Be sure to dispose of used batteries in accordance with local waste disposal rules.
- When disposing the equipment, remove the batteries, separate the case, circuit boards, and cables, and dispose of all components in accordance with local waste disposal rules.

## Usage Guidelines:

- Before setting up, make sure that the transmitter and receiver are tuned to the same frequency. Do not use two or more transmitters operating on the same frequency.
- Turn the MIC/LINE switch on the rear of receiver to adjust receiver output level to match input level requirements of an audio mixer or amplifier.
- Use the gain control to adjust the sensitivity of the transmitter's audio to the level of the connected laval microphone or instrument.
- To avoid interference, do not put the receiver too near to metallic objects, and avoid obstructions between, the transmitter and receiver.
- Move the transmitter around the area where you propose to use the system. If you find any dead spots, change the receiver position. If that does not work, try to avoid the dead spots.
- Avoid the interference from TV, radio, other wireless appliances and etc.
- Avoid extremely dirty or dusty environments.
- Avoid areas where there is extremely high humidity.

## BASIC CONNECTIONS:

Connect the receiver output to the audio mixer or amplifier input, using a standard audio cable with 3-pin XLR connectors or 6.3mm phone plugs. Never use the balanced and unbalanced audio outputs at the same time as this may cause signal loss or increased noise.

Figure 1: Common Connections

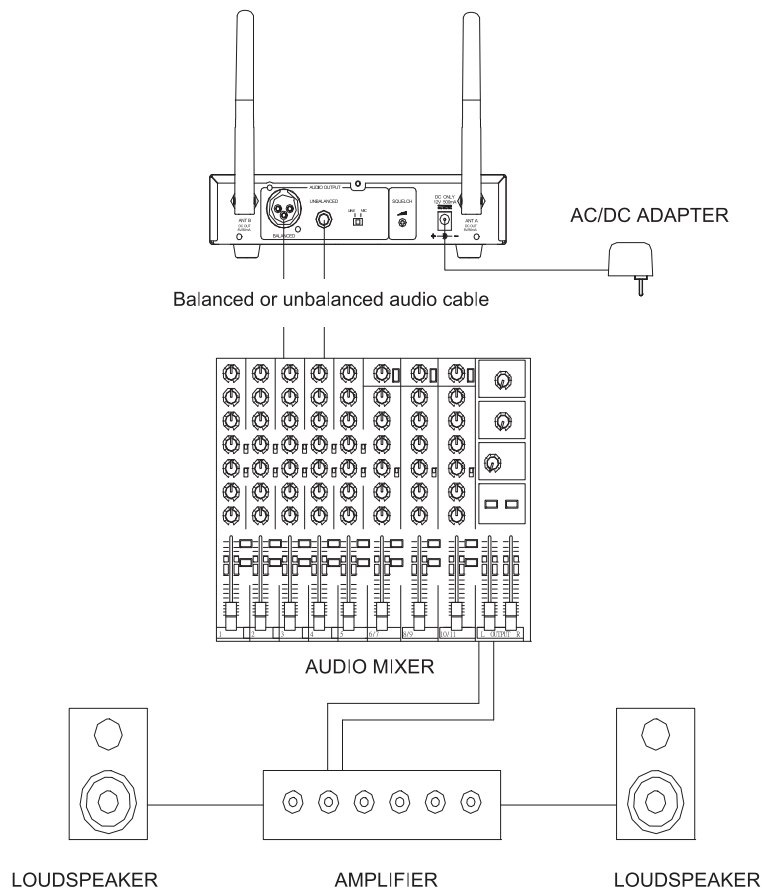

## REDBACK® C 8870F UHF Band Diversity Wireless Mic System

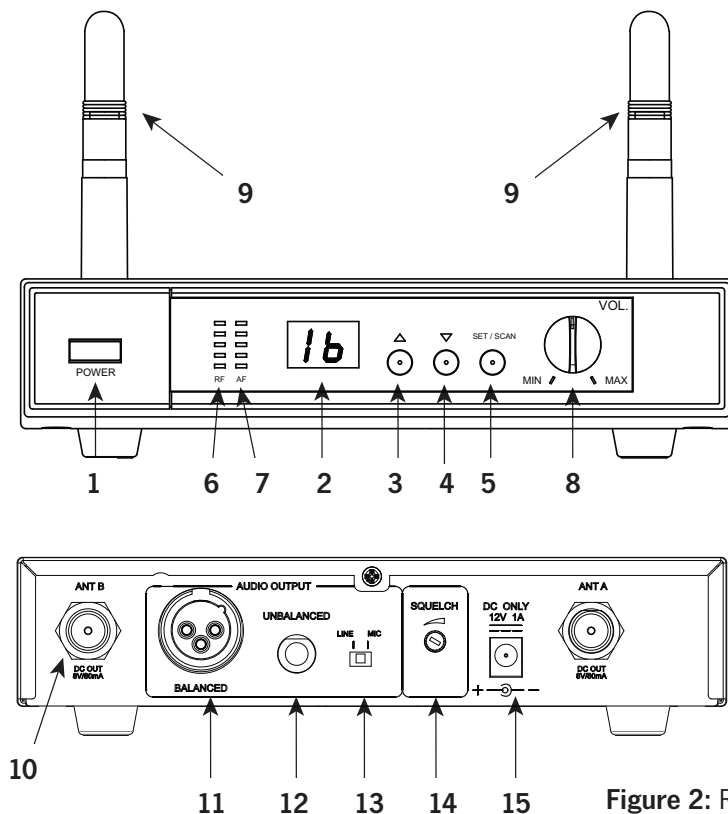

1. Power
2. LED Channel Display
3. Channel Forward Button
4. Channel Backward Button
5. SET/SCAN Button
6. RF Level Indicators
7. AF Level Indicators
8. VOL Volume Control
9. Antenna
10. ANT Antenna Input Connector
11. BALANCED Output
12. UNBALANCED Output
13. MIC/LINE Switch
14. SQUELCH
15. DC IN

Figure 2: Receiver Functions - True Diversity, Detachable Antenna

1. **POWER:** Press for four seconds to power the receiver on or off.
2. **Channel Display:** LED channel displays the channel number.
3. **Channel Forward Button:** When the LED display starts flashing, press this button to change the channel forward.
4. **Channel Backward Button:** When the LED display starts flashing, press this button to change the channel backward.
5. **SET/SCAN Button:**
  - a. Auto Scan - Press three seconds to search for the next clean channel automatically.
  - b. Set Channel: Press one second to let LED channel display flashing, then press the channel button or to change the channel. Wait LED channel display flashing five times to lock the channel or press SET button for one second to lock the channel.
6. **RF Level Indicators:** five-segment meter glows to indicate RF signal strength. The more segments glow, the stronger is the received signal. If none of these segments glow, no signal is being received.
7. **AF Level Indicators:** five-segment meter glows to indicate audio signal strength. The greater the number of segments that glow, the stronger is the received signal. If none of these segments glow, no signal is being input.
8. **VOL - Volume Level Control:** Use this rotary control to adjust the receiver output level to match the input sensitivity of an audio mixer or an amplifier.
9. **Antenna:** Fixed-length UHF antenna poles permanently mounted.
10. **ANT - Antenna Input Connector:** BNC-type connectors provide connection to the supplied antennas or to coaxial cable used with an antenna divider, antenna boosters or remote antennas.
11. **BALANCED Output:** 3-pin XLR connector provides balanced low-impedance output.
12. **UNBALANCED Output:** Unbalanced 6.3mm mono jack audio output for connecting to, e.g., a guitar amplifier.
13. **MIC/LINE Switch:** Select output of XLR balanced connector or 6.3mm unbalanced phone jack. It can be set for microphone (-20dB) or line-level (0dB).
14. **SQUELCH:** The SQUELCH level is adjustable via the adjustment dial at the back of the unit using a screwdriver. SQUELCH adjusts the output level to protect the signal from external noise.
15. **DC ONLY:** d.c. input connector for the supplied a.c. adaptor.

**Operation - Receiver (Manual Scan mode):**

- i. Connect the cable, one end to the balanced or unbalanced output jack of the receiver, the other end to the mic mixing input of amplifier, audio mixer etc.
- ii. Ensure SQUELCH is set to minimum and press the POWER button for a few seconds to turn the unit on.
- iii. Press SET/SCAN button for one second so that the LED display starts flashing.
- iv. Press Channel Forward / Backward buttons to set the receiver channel. Please set the same frequency channel (see Tables 1 and 2 in the Appendix) on the transmitter and receiver. If interference occurs from an outside source, change the channel frequency.
- v. Stop pressing the buttons and let the LED display number flash five times to lock the setting.
- vi. For best results set the VOL control at about three quarters level (three o'clock position) and adjust mixer / amplifier level to suit. Adjust SQUELCH as needed to limit noise in the signal.
- vii. When the receiver is not in use, switch it off and disconnect it from mains power.

**Operation - Receiver (Auto Scan mode):**

- i. Connect the cable, one end to the balanced or unbalanced output jack of the receiver, the other end to the mic mixing input of amplifier, audio mixer etc.
- ii. Ensure SQUELCH is set to minimum and press the POWER button for a few seconds to turn the unit on. Also turn on the amplifier or mixer and any connected hi-fi devices.
- iii. Press SET/SCAN button for three seconds to search for the next interference-free channel automatically. The auto-scan system should stop at the next interference-free channel.
- iv. Let the LED display flash five times to lock the setting.

**Note 1:** If user needs to set up a multi-receiver system, please keep your previous receiver-microphone pair powered on. A maximum number of six Redback systems can be used in the one location at the same time. To use the maximum number of frequencies in the one location at the same time consult the channel guide, in Table 2 in the Appendix.

**Note 2:** Setting the SQUELCH high (towards max) will reduce the range of the system.

**Note 3:** There are two types of transmitters available. Both are compatible with this unit. Series 1 transmitters have a DIP switch for frequency selection. Series 2 transmitters have a rotary switch for frequency selection. Please refer to Table 1 in the Appendix for details.

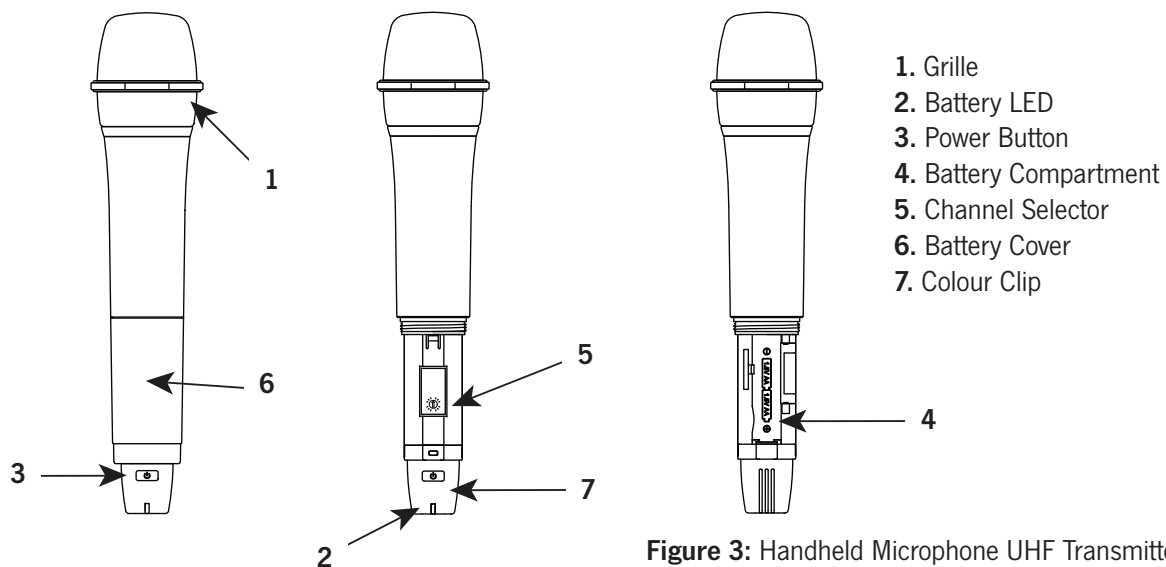

**Figure 3:** Handheld Microphone UHF Transmitter Functions

### **C8872E - HANDHELD MICROPHONE TRANSMITTER (See Figure 3)**

The handheld microphone operates in UHF band frequency with PLL synthesized control circuitry. There are 16 pre-programmed selectable UHF frequencies available to avoid interference. The microphone uses either unidirectional dynamic or unidirectional condenser capsules with varying characteristics.

#### **Features:**

- High sensitivity cardioid capsule reduces unwanted handling noise to a minimum.
- Special noise absorption parts inside the barrel, which eliminate switch shock noise and handling noise.
- Easy-opening battery compartment for quick replacement. Requires two AA-sized 1.5 V batteries (not supplied) to power the condenser mic.
- Low battery LED indicator.

- 1. Grille:** Protects the microphone capsule and helps reduce breath sounds and wind noise. The grille for the various microphone capsules differ in appearance.
- 2. Battery LED:** Indicates when the power to the unit is on. It also indicates battery life status. When the power is turned on, the red LED will stay on to indicate the batteries have sufficient energy to power the unit. If the LED fails to light, the battery is either dead or not positioned correctly. If the LED stays flashing, it indicates that the battery will soon be out of power and should be replaced.
- 3. Power:** Press for two seconds to turn transmitter on or off.
- 4. Battery Compartment:** Insert two AA-size 1.5V dry or rechargeable batteries into the holder and ensure that the polarity of batteries accords with the polarity (+) and (-) indicators marked on the battery housing.
- 5. Channel Selector:** Changes transmitter channel setting. Use a screwdriver to turn the dial.
- 6. Battery Cover:** Unscrew the bottom half of the microphone to expose battery compartment and channel selector.
- 7. Colour Clip:** This colour clip helps to mark the same frequency of receiver and transmitter.

#### **Operation - Handheld Microphone:**

- i. Make sure the Receiver unit is plugged into the ac power, switched on and a vacant frequency chosen and set. Also turn on the amplifier or mixer and any other connected hi-fi devices.
- ii. Unscrew battery cover and insert batteries into the battery holder correctly.
- iii. After setting the frequency using a screwdriver to the same frequency chosen for the receiver, place the battery cover back onto the microphone.
- iv. Push the power switch to turn mic on. The LED indicator will appear as a steady red light.
- v. Test the microphone and adjust the levels on the receiver or your audio mixer or amplifier.
- vi. Push the power button again to turn the mic off. Remove the batteries from the unit if it is not to be used for a long time. This will prevent damage to the unit that a defective or leaking battery may cause.

**Figure 4:** Beltpack UHF Transmitter Functions

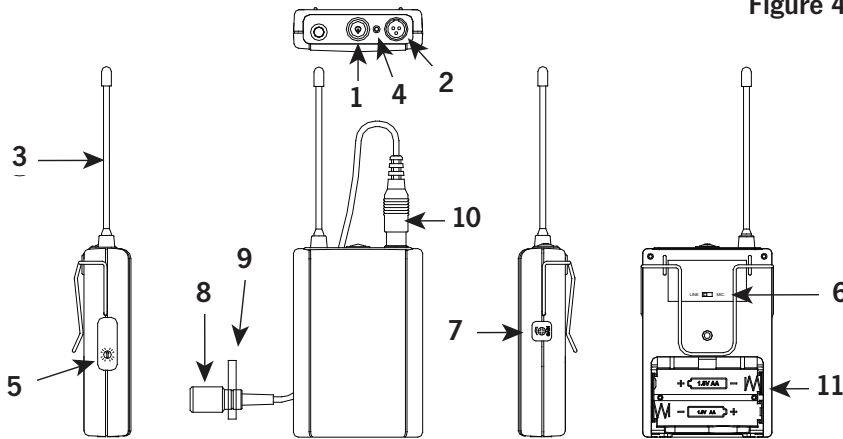

**C8875E - BELTPACK TRANSMITTER: (See Figure 4)**

The Beltpack Transmitter operates in UHF band frequency with PLL synthesized control. There are 16 pre-programmed selectable UHF frequencies available to avoid interference. The microphone uses unidirectional condenser cartridges with varying characteristics. Insert two 1.5V d.c. AA size batteries to power the condenser mic.

A range of microphones and pickups are available for the Beltpack including tie-clip mic, lecture type headset, aerobics type headset, and guitar pickup. The Beltpack is equipped with a MIC/LINE switch and GAIN control.

1. **POWER:** Press for 4 seconds to power the transmitter on or off.
2. **Mini XLR Connector:** The included electret lapel microphone cable is inserted into the connector on the top of the bodypack transmitter case. The optional guitar pick up cable also connects here.
3. **Antenna:** Permanently connected helical antenna.
4. **Battery LED:** Indicates when the power to the unit is on. It also indicates battery life status. When the power is turned on, the red LED will stay on to indicate the batteries have sufficient energy to power the unit. If the LED fails to light, the battery is either dead or not positioned correctly. If the LED stays flashing, it indicates that the battery will soon be out of power and should be replaced.
5. **Channel Selector:** Changes transmitter channel setting. Use a screwdriver to change the channels.
6. **MIC/LINE Selector:** The switch sets the audio input either to microphone level or line level.
7. **GAIN:** The rotary control adjusts the input audio level of the transmitter. The gain adjustment range is 10dB. Use a screwdriver to change the level.
8. **Microphone:** The unidirectional electret condenser unit features a wide frequency response for a warm, rich bass and a clear sound.
9. **Tie Clip:** To clip on the tie or lapel to allow free-movement.
10. **Cable:** With mini XLR connector cable to connect to the transmitter.
11. **Battery Compartment:** Insert two AA-size 1.5V dry or rechargeable batteries into the slots and ensure that the polarity of batteries accords with the polarity (+) and (-) indicators marked on the battery compartment.

**Operation - Beltpack:**

- i. Make sure the receiver unit is plugged into the a.c. power, switched on and a vacant frequency chosen and set. Also turn on the amplifier or mixer and any other connected hi-fi devices.
- ii. Push to open the battery cover and insert batteries into the battery holder correctly. Replace battery cover.
- iii. Connect the microphone or guitar pickup to the unit using the mini XLR (see Note below).
- iv. Set the MIC/LINE switch to match the sound source (mic or line). Line is for guitar input.
- v. After setting the frequency using a screwdriver to the same frequency chosen for the receiver, push the POWER switch to turn the unit on. The LED indicator will appear as a steady red light.
- vi. Use the supplied screwdriver to adjust the GAIN to an appropriate level.
- vii. Test the microphone or instrument and adjust the levels of the receiver or your audio mixer or amplifier.
- viii. Push the POWER button to turn the unit off when the Beltpack is not being used. Remove the battery if the device is not to be used for a long time. This will prevent damage to the unit that a defective or leaking battery may cause.

**Note:** When using an instrument, for step (ii), plug the 6.3mm phone plug of the optional guitar cable to the output jack on the instrument, and the mini XLR end into audio input connector on the beltpack transmitter.

## SETTING UP THE WIRLESS RADIO SYSTEM:

**Note:** Prior to setting up, please check that the transmitter and receiver are tuned to the same frequency. Two or more transmitters operating on the same frequency can not be used at the same time and in the same area. So for each extra transmitter, select a different frequency which can be used simultaneously in the local area.

### Connecting the receiver to power:

1. Plug the antennas into the BNC sockets on the receiver, if the antennas are detachable, and point them upward.
2. Check that the voltage of the supplied a.c. adapter conforms to the voltage available (110V or 220V) in the local area. Using the wrong a.c. adapter may cause irreparable damage to this unit.
3. Plug the feeder cable of the supplied a.c. adapter into DC ONLY socket on the receiver. Then plug the a.c. adapter into a power outlet.

### Connecting the receiver to an audio mixer or an amplifier:

In order to make sure the sound quality and avoid distortion, please adjust the volume level according to following instructions.

- When using a standard audio cable with 3-pin XLR connectors or 6.3mm phone plugs to plug into the MIC IN on the audio mixer or on the amplifier, turn the VOL volume level control of the receiver to around the one o'clock position, the output level for balanced and unbalanced output is about at 77mV.
- When using a standard audio cable with 3-pin XLR connectors or 6.3mm phone plugs to plug into the LINE IN on the audio mixer or on the amplifier, turn the VOL volume level control of the receiver to around the MAX position, the output level for balanced and unbalanced output is about at 770mV.

**Note:** Never use the balanced and unbalanced audio outputs at the same time! This may cause signal loss or increased noise.

**Figure 5:** Fitting the rack mounting brackets to the unit.

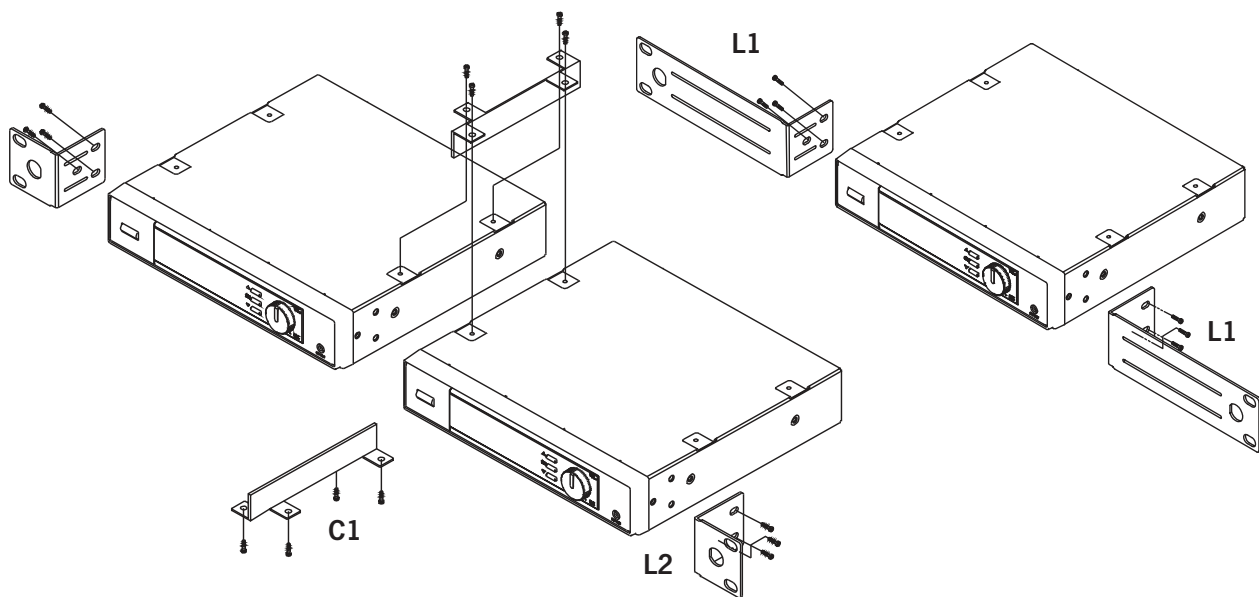

To combine two receivers in a 19" standard rack by using two short L-type plastics rack ears (L2) and two metal connecting plates (C1). (Each system includes an L2 and a C1.)

To mount a receiver in a 19" standard rack by using two L type long metal rack ears (L1). (L1 is an optional accessory check with your vendor for availability.)



**Figure 6:** An antenna booster is highly recommended for long distance requirements such as in stadiums and auditoriums. The antenna booster (C 8842 or C8842A) can be wall or mic stand mounted to with an optional bracket (C 8843 or C 8843A to suit C 8842A).

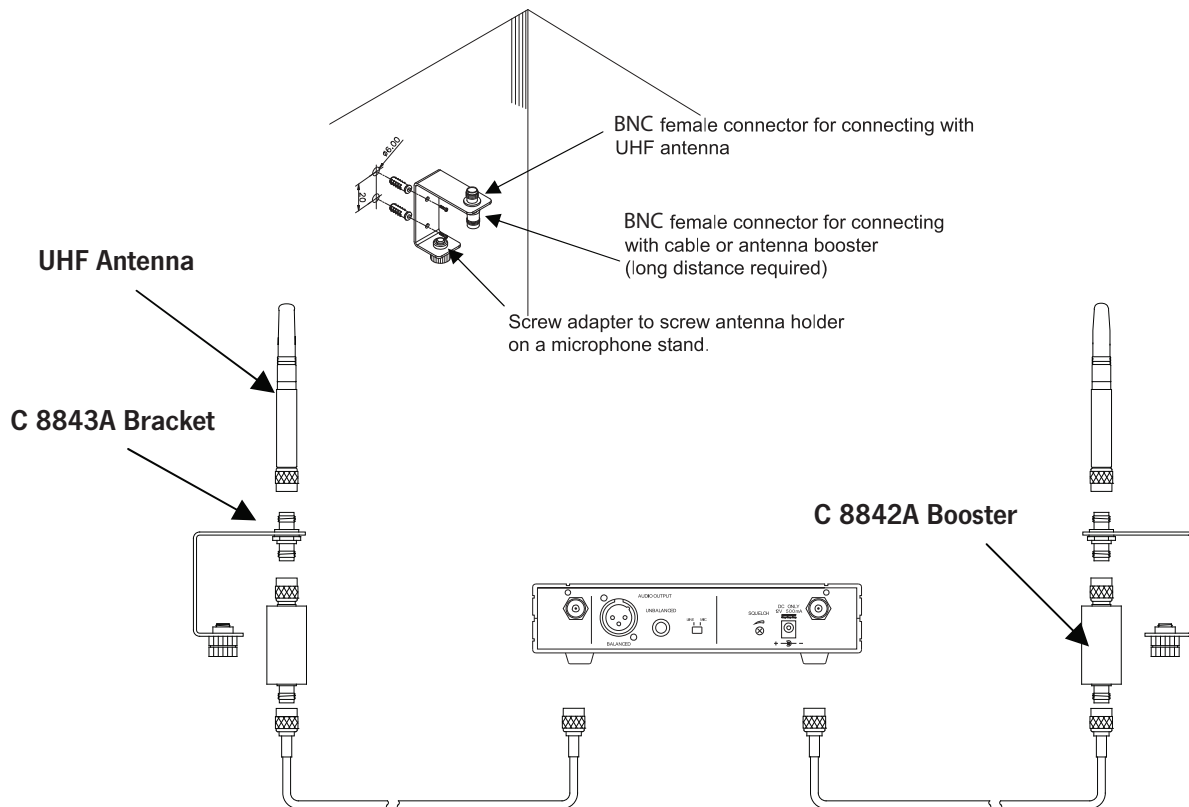

## APPENDIX:

### TROUBLE SHOOTING:

Problem	Solution
No Sound	• Check the power supply of the microphone and receiver.
	• Check that the transmitter and receiver are tuned to the same frequency.
	• Check whether the hi-fi appliance is switched on and the receiver output is connected to the audio amplifier or mixer output.
	• Check whether the transmitter is too far away from the receiver, or the SQUELCH is set too high.
	• Check whether the receiver is located too near metal objects or there are obstructions between transmitter and receiver.
Sound Interference	• Check the antenna location.
	• When using two or more microphone sets simultaneously, ensure that the chosen frequencies for each microphone do not interfere with each other.
	• Check whether the interference comes from other wireless devices, mics, TV, radio etc.
Distortion	• Check to see if the receiver volume is set too high or too low.
	• Check whether there is any unwanted interference coming from other devices.

**Table 1:** Frequency Cross-Reference Chart

<b>CH 1</b>	520.125MHz	<b>CH 9</b>	534.225MHz
<b>CH 2</b>	520.825MHz	<b>CH 10</b>	535.625MHz
<b>CH 3</b>	521.925MHz	<b>CH 11</b>	541.125MHz
<b>CH 4</b>	525.025MHz	<b>CH 12</b>	543.225MHz
<b>CH 5</b>	525.925MHz	<b>CH 13</b>	544.125MHz
<b>CH 6</b>	528.525MHz	<b>CH 14</b>	544.825MHz
<b>CH 7</b>	529.425MHz	<b>CH 15</b>	545.725MHz
<b>CH 8</b>	532.325MHz	<b>CH 16</b>	549.525MHz
<b>Series 2 Transmitters, Rotary Switch MHz</b>			

**Table 2:** Receiver Frequency groups chart

Group A		Group B		Group C		Group D	
CH	Frequency	CH	Frequency	CH	Frequency	CH	Frequency
1	520.125MHz	2	520.825MHz	1	520.125MHz	2	520.825MHz
2	520.825MHz	5	525.925MHz	3	521.925MHz	4	525.025MHz
3	521.925MHz	7	529.425MHz	5	525.925MHz	8	532.325MHz
6	528.525MHz	8	532.325MHz	7	529.425MHz	10	535.625MHz
7	529.425MHz	9	534.225MHz	9	534.225MHz	12	543.225MHz
9	534.225MHz	10	535.625MHz	10	535.625MHz	14	544.825MHz
10	535.625MHz	11	541.125MHz	11	541.125MHz	15	545.725MHz
16	549.525MHz	14	544.825MHz	13	544.125MHz	16	549.525MHz

Use only these channels in the same location at the same time. Other channels used together will not provide interference free transmission.

**SPECIFICATIONS:**

**Receiver:**

Carrier Frequency Range:	UHF band 520-550MHz
Oscillator:	PLL synthesized
Modulation:	FM
Frequency Stability:	±0.005%
S/N ratio:	>100dB at 20kHz deviation and 60dBV antenna input
Maximum Deviation:	±20kHz
Image and Spurious Rejection:	80dB minimum
Receiving Sensitivity:	6dBµV
Selectivity:	50dB
AF Response:	50Hz to 15kHz
T.H.D.:	1% (at 1kHz)
IF Frequency:	1st - 243.95MHz; 2nd -10.7MHz
Dynamic Range:	>100 dB
Tone Signal:	32.768kHz
Audio Output:	Balanced and unbalanced outputs
Power Supply:	12Vdc
Current Consumption:	About 250mA

**Handheld/Beltpack Transmitter:**

Carrier Frequency Range:	UHF band 520 - 550MHz
RF Power Output:	10mW (max.)
Oscillator:	PLL synthesized
Frequency Stability:	±0.005%
Maximum Deviation:	±20kHz with limiting compressor
Spurious Emission:	>60dB below carrier frequency
T.H.D.:	<1% (at 1kHz)

**Microphone Cartridge:**

- Handheld: Unidirectional dynamic or Unidirectional electret condenser unit
  - Lapel: Unidirectional electret condenser unit
- |                      |                                |
|----------------------|--------------------------------|
| Operating voltage:   | 3Vdc x 2 AA 1.5Vsize batteries |
| Current Consumption: | 120mA (MAX.)                   |

**Note:** Design and specifications are subject to change without notice.

Distributed by Altronic Distributors Pty. Ltd. Perth. Western Australia.  
Phone: 1300 780 999 Fax: 1300 790 999  
Internet: [www.altronics.com.au](http://www.altronics.com.au)

26/11/2014