

1. ENGAGE LOCK TESTER

A. Using the lift handle place the lock tester on the fifth wheel with the kingpin in line with the throat. (See figure 1)



FIGURE 1

B. Engage the hook over the front skirt of the fifth wheel by depressing and rotating the spring loaded tee handle. (See figure 2)

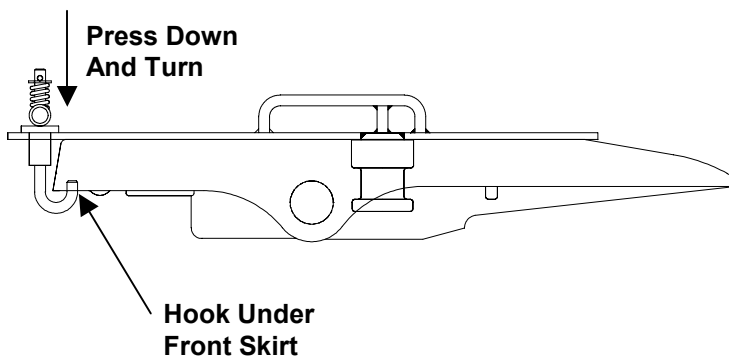

FIGURE 2

C. Lock the fifth wheel by swinging the lock tester handle forward until the fifth wheel release handle moves to the closed position. (See figure 3)

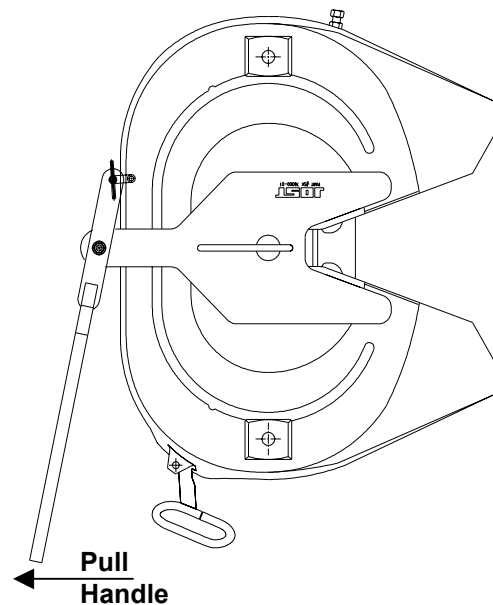
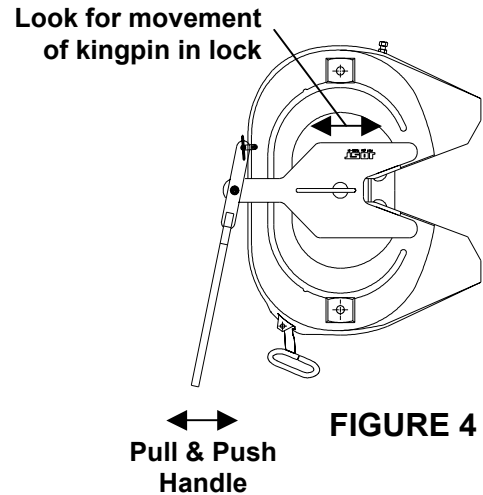

FIGURE 3

2. CHECK ADJUSTMENT - Lock and unlock several times using the tester

A. THE LOCK IS PROPERLY ADJUSTED IF: The wheel locks and unlocks easily each time and the lock tester rotates freely.

B. THE LOCK IS TOO LOOSE IF: You feel fore-aft play when pulling and pushing on the lock tester handle (see figure 4)



C. THE LOCK IS TOO TIGHT IF: The lock tester does not rotate freely when attempting to rotate it in the lock. (See figure 5)

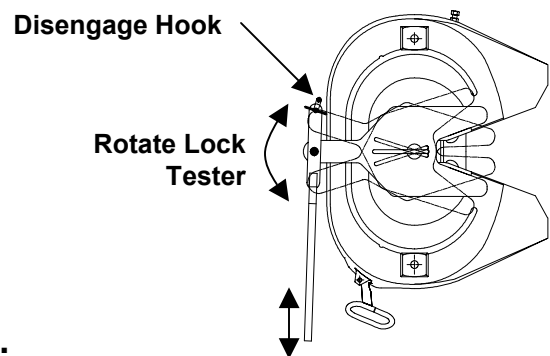

3. CORRECT IMPROPER ADJUSTMENT.

A. IF IT IS TOO TIGHT: loosen the jam nut, turn the adjustment screw clockwise one full turn and reset the jam nut. Then, lock and unlock several times, repeat if necessary.

B. IF IT IS TOO LOOSE: loosen the jam nut, turn the adjustment screw counterclockwise one full turn and reset the jam nut. Then, lock and unlock several times, repeat if necessary.

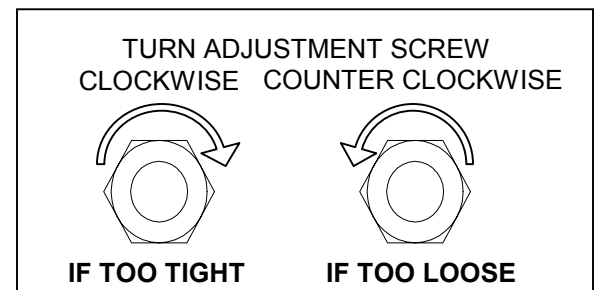

The right to alter specifications is reserved.