

Operating instructions

Directly coupled screw compressors

Series
C 3 L...C 7 L
C 3 LR...C 7 LR
C 3 LDR...C 7 LDR

Separate manuals:
Compressor control
Refrigeration compressed air dryer (C LDR)



Operating instructions for directly coupled screw compressors

- C 3 L / C 3 LR / C 3 LDR (2.2 kW)
- C 4 L / C 4 LR / C 4 LDR (3.0 kW)
- C 5 L / C 5 LR / C 5 LDR (4.0 kW)
- C 7 L / C 7 LR / C 7 LDR (5.5 kW)

BOGE KOMPRESSOREN
Postfach 10 07 13
33507 Bielefeld

Otto-Boge-Straße 1-7
33739 Bielefeld

Phone: +49 5206 601-0
Fax: +49 5206 601-200
Mail: info@boge.com
Net: www.boge.com

Issue: 05 / 2011
No. 596.1144.01
Nominal price: € 5.00

Index

Part 1: General	1.1	General safety instructions	1
		Safety instructions for compressor operation	1
		Special hazard warnings.....	2
		Electrical energy hazards	3
		Obligations of the owner	3
		Personnel requirements.....	4
		Personal protective equipment	4
		Safety instructions for maintenance and repair of the compressor...	4
		Accident prevention regulations.....	5
	1.2	Introduction	6
		Symbols used	7
		Symbols on the compressor	8
		Intended use	9
		Foreseeable Misuse	9
	Transport damage	9	
	Data on the type plate.....	10	
	Service.....	10	
Part 2: Product description	2.1	Technical data.....	11
	2.2	Function description	14
		Function principle of the air end.....	14
		Air circuit.....	15
		Oil circuit.....	16
	2.3	Compressor control	17
		Network pressure.....	17
		Operating states	17
		Operating modes	17
		Short operating times.....	18
	2.4	Control devices.....	18
		Operating pressure transmitter	18
	2.5	Safety and monitoring devices.....	18
		General.....	18
		Safety valve	19
		Safety temperature limiting device.....	19
		Monitoring the drive motor	19

Part 3: Installation	3.1	Transport and storage	21
		General	21
		Transport possibilities	21
		Intermediate storage	22
	3.2	Compressor room	23
		Installation, maintenance conditions and application for compressed air receivers arranged below or separately	23
		Installation surface	23
		Fire protection	23
		Sound protection.....	24
		Admissible environmental influences.....	24
		Ventilation	24
		Cooling air requirement	25
		Condensate disposal	25
	3.3	Installation	26
		General	26
		Checking the delivery scope	26
	Installing the compressor	26	
	Connecting the compressor to the compressed air network.....	27	
	Checking the oil level.....	27	
3.4	Electrical connection	27	
3.5	Commissioning	28	
	Check installation requirements.....	29	
	Checking the rotational direction	29	
	Check compressed air outlet for tightness.....	29	
	Opening the stop valves	30	
	Checking for leaks	30	
	Conduct trial run	30	
	Commissioning following extended stoppages	31	
	Refrigeration compressed air dryer	31	
3.6	Dismantling	32	
Part 4: Faults	4.1	General	33
	4.2	General faults	33
Part 5: Maintenance	5.1	Safety instructions	35
	5.2	General	37
		Maintenance through BOGE customer service	37
	Review of regular maintenance work.....	37	
	Maintenance intervals	38	

	General information concerning the lubricants used	40
	Disposal of used operating material	41
	Pressure hoses.....	41
	Spare and wearing parts.....	41
5.3	Regular maintenance work.....	42
	Draining off the condensate from the compressed air receiver	42
	Draining off the condensate from the compressed air receiver with automatic condensate separator	43
	Clean or change suction filter	43
	Cleaning the filter cartridge.....	44
	Drive motors with permanent lubrication	44
	Checking the oil level, topping up oil	45
	Changing the oil filter	46
	Changing the oil separator.....	47
	Oil change.....	48
	Flushing the oil circuit	50
	Cleaning the compressed air/oil cooling unit	51
	Checking the safety valve.....	52
5.4	Spare parts and optional equipment	53
	List of spare and wearing parts (for maintenance)	53
	List of available optional equipment.....	53
Part 6:	6.1 Guidelines and standards complied with.....	55
Appendix	6.2 Flow chart.....	55
	Air cooled version, standard	56
	6.3 List of maintenance and service work.....	58

1.1 General safety instructions



Caution!

Nonobservance of the following safety instructions may lead to injuries and damage to the compressor.

Also observe the generally valid safety and accident prevention regulations in addition to the information in these operating instructions!

Safety instructions for compressor operation

1. Ensure that no commissioning and maintenance work on the compressor is undertaken until these operating instructions are understood.
2. Only use the compressor for its intended use, as described in these operating instructions.
3. The owner must ensure:
 - that only appropriately trained and authorized personnel work on this compressor,
 - that no persons work on this compressor, whose ability to react is restricted due to misuse of e.g. drugs, alcohol, medication etc.,
 - that the operating, maintenance and repair personnel has been made fully familiar with all safety instructions, and that they are being observed,
 - that the compressor is only operated in a safe operating condition.
4. Avoid any operating method which may impair the safety of the compressor.
5. Always wear your compulsory personal protective equipment as a protection against injuries from sharp corners or edges when working on the compressor.
6. To avoid dangers from debris or parts lying around, the service area of the compressor has always to be kept tidied up and clean.
7. Always squat when working on components mounted at low height, never stoop. When working on components mounted higher up always stand upright and erect.
8. Do not exceed the limit value for the final compression pressure specified on the type plate.
9. Do not operate the compressor without the attendant protection and safety devices.
Do not dismantle any built-in safety devices or put them out of operation. Ensure that all safety claddings and doors are closed prior to commissioning/starting up the compressor and that they are not opened during operation.
10. Place the compressor out of operation as described in these operating instructions, when dismantling the safety claddings or safety devices for repair or maintenance work. Reattach and close all cladding and safety devices immediately upon completion of the repair or maintenance work.
11. Only operate the compressor using the additional equipment (options) recommended or authorized by the manufacturer.

12. Undertake conversions and modifications of the compressor only with BOGE prior approval, taking all relevant safety regulations into consideration. The manufacturer is not liable for damages resulting from independent modifications on the compressor.
13. Never start the compressor when one or several parts (e.g. cable, plug) are damaged, when not in perfect working order and when damage is detected or suspected.
14. Observe all safety and danger signs directly attached on the compressor!

Special hazard warnings

- Always wear your compulsory personal protective equipment when working on pressure pipes and connections!
- A protective grid serves to prevent you from accidentally reaching into the impeller of the cooling fan.



Caution: Risk of injury!

A protective grid serves to prevent you from accidentally reaching into the impeller of the cooling fan!

Please note that the cooling fan may run on for a certain time even after the compressor has been switched off!

- During operation, the compressor generates a high sound pressure level which may cause permanent hearing damage due to continuous noise stress. As a rule, the compressor may only be operated with its housing cover closed. Make sure to additionally wear a hearing protection in case of a noise pressure level above 80 dB(A)!
- A rigidly screwed-down protective cover prevents you from accidentally reaching into the drive coupling during operation of the compressor.



Caution: Risk of injury!

Never operate the compressor with dismantled coupling protection. There is a risk that you reach into the fast rotating coupling!

Any servicing on the coupling may only be carried out during standstill of the compressor!

- The pressure relief valves as well as the intake and exhaust opening on the suction filter are mounted at the back in order to prevent the compressed air exhaust jet from pointing toward the operator.

Electrical energy hazards



Warning: Voltage!

There is danger of life when working on the electrical equipment of the compressor!

- Disconnect mains connection prior to starting to carry out works on the compressor and use padlock to secure against switching on again.
- Only duly authorized professional electricians (e.g. plant electricians) are allowed to carry out works in the electrical area of the machine.
- Make sure to check the electrical equipment of the compressor at regular intervals for defects such as loose connections or scorched cables and have any defects repaired immediately.
- Make sure to have all electrical equipment and fixed electrical installations checked by a professional electrician at least every 4 years.
- Any modifications that may have been carried out after examination must conform to DIN EN 60204-1:2007.
- Make sure to check all safety installations on the machine for proper functioning at regular intervals.
- Only use original fuses.

Obligations of the owner

The owner is obliged to,

- operate the compressor only in technically perfect condition,
- check the Emergency Stop device of the compressor regularly for completeness and functionality,
- assess the hazards of the machine working places in his area of responsibility and to issue the ensuing operating instructions,
- to name a person responsible being in charge of the safe operation of the machine as well as the coordination of all service work performed on it,
- avoid stress situations while operating the compressor by means of technological and organizational operation scheduling,
- ensure a proper workplace lighting at the compressor control section according to the local health and safety regulations,
- observe the safety data sheet of the used lubricants and to customize the personnel all information as to said data sheet,
- provide the compulsory personal protective equipment and to stipulate and check the wearing of said protective equipment on a regular basis,
- assign the personnel responsible for various tasks and work on the machine,
- instruct the personnel on a regular basis with respect to all obligations as to compressor related preservation of safety and tidiness.

Personnel requirements

Work on and with the compressor may only be carried out by personnel duly authorized by the owner of the compressor.

The personnel working on the compressor has to observe all industrial safety regulations and operating instructions, properly recognize responsibilities and read and understand the operating instructions. It is essential to wear the compulsory personal protective equipment when working on the compressor!

Personal protective equipment

In general for all work on the compressor

- protective clothing,
 - chemicals resistant gloves,
 - slip-resistant safety shoes and
 - hearing protection, if applicable,
- are compulsory.

For special duties

- protective helmets (for transport work with lifting gear) and
 - safety goggles (when working on the compressed air system, on the control pneumatics and/or on the cooling system of the built-in dryer)
- must be worn.

Before starting work using oils or greases a skin protection cream must be applied. Having finished the work a skin care product must be applied.

Safety instructions for maintenance and repair of the compressor



Caution!

Only use original spare parts, compressor oils and operating materials released by BOGE during repair or maintenance!



Warning: Voltage!

When working on the electrical system there is a constant danger of getting into contact with live parts!

To avoid such dangers the mains connection must be equipped with a disconnecting device!

The mains disconnecting device has to meet the requirements of DIN EN 60204-1:2007!

1. Ensure that maintenance work is only carried out by appropriately trained persons.
2. Ensure that setting work, malfunction rectification and repair is only carried out by specialists or appropriately trained persons.

3. Prior to maintenance or repair work:
 - Press Emergency Stop button.
 - Open mains disconnecting device.
 - Secure mains disconnecting device against unintentional switching on by means of a padlock.
 - Fix a warning label to the control and fill in the name of the person responsible who is authorized to switch on the machine again.
 - Check to ensure that all parts are currentless.
 - Disconnect the compressor from the compressed air network (relieve or block pressurized lines).
4. Exercise extreme caution during repair or maintenance work requiring the compressor to be operational.
Ensure that persons keep out of reach of the hazardous area.
5. Ensure that work on the electrical equipment is only executed by qualified electricians.
6. Work on parts and devices under current is prohibited. Exceptions are governed by the appropriate regulations, e.g. DIN VDE 0105.
7. Prior to starting work on the electrical system the power supply has to be switched off and secured against unintentional switching on again. Immediately after having finished the work all dismantled claddings and safety devices must be refitted.
8. The operator is responsible to check the compressor daily for externally visible damage and defects, and to immediately report any changes (including operational behaviour).
9. When the automatic restart (Auto-Restart) is activated, the compressor will start automatically following a voltage loss. Prerequisite: The net pressure is lower than the set switch-on pressure.

Accident prevention regulations

The owner of a compressor plant is responsible to ensure that it is properly installed, operated and maintained.

Prior to commissioning, owners in the Federal Republic of Germany urgently have to read the currently valid regulations of the Main Association of the Industrial Employers' Liability Insurance. Apart from other regulations particularly the Ordinance on Industrial Safety and Health (BetrSichV) is applicable.

The regulations are available at the following locations:

Berufsgenossenschaft (Industrial Employers' Liability Insurance)

Carl-Heymanns-Verlag KG, Luxemburger Straße 449, D-50939 Köln

Beuth Verlag GmbH, Burggrafenstraße 6, D-10787 Berlin

For operation of the compressor plant outside the Federal Republic of Germany, the accident prevention regulations of the country, where the compressor is operated, must be observed in addition to the data contained in these operating instructions.

In the event that measures are required above and beyond the legal regulations specified in the Federal Republic of Germany or the data contained in these operating instructions, then it is of utmost importance that these be carried out prior to commissioning the compressor plant.

1.2 Introduction

The purpose of these operating instructions is to familiarize the user with the function and all application possibilities of the compressor.

These operating instructions contain important information on how to operate the compressor safely, economically and according to its intended use. Observing these operating instructions will assist in avoiding danger, to reduce repair costs and down times and to increase the reliability and service life of the compressor. It contains important information concerning the required maintenance and repair measures, assists in case of malfunctions and contains data concerning spare and wearing parts.

The operating instructions must be available to the compressor operating personnel at the place of operation, at all times.

The operating instructions must be carefully read and applied by all persons engaged to undertake the following work on the compressor:

- Operation, including fault rectification and daily care
- Maintenance (service, inspection, repair)
- Commissioning
- Transport

The compressor and its additional equipment must not be installed and commissioned until the operating instructions are understood.

These operating instructions can be supplemented with instructions on the basis of existing national regulations concerning accident prevention and environmental protection.

In the illustrations, the compressor is shown in part without safety cladding or safety devices for better visualization. However, operation without these components is prohibited!

Symbols used

In these operating instructions the most important safety notes and tips are especially characterized by the following symbols:

**Caution: Risk of injury!**

This symbol indicates information warning of possible danger to life and limb of the operator or other persons.

**Attention!**

This symbol indicates information warning of dangers to life and limb of the operator or other persons or dangers, which might destroy or damage the compressor.

**Warning: Voltage!**

This symbol indicates information warning of life threatening electrical voltage levels.
It indicates work which must be exclusively performed by skilled electricians.

**Note!**

This symbol indicates information and tips concerning the economical and careful operation of the compressor.

Symbols on the compressor

**Note!**

All warning signs on the compressor and in its surrounding must always be kept in a legible condition. Missing or damaged signs must be replaced at once!

The following symbols and warning signs are fitted on the compressor:

**Warning!**

Hot surfaces: Do not touch!

**Warning!**

The unit is operated by remote control, and might start without warning.

**Note!**

Instructions for the operating personnel must be read.

**Prohibited!**

Never open the valve before the air hose (connection to the compressed air network) is connected.

Intended use



Caution!

BOGE compressors, including their additional equipment, are exclusively intended for the compression of air. The air taken in must not contain any explosive or chemically instable gases or vapours.

Do not exceed the specified final compression temperature.

BOGE compressors are designed for stationary operation.

Ensure that they are only installed and operated in dry and clean rooms.

Operation and control are designed to be executed by trained and authorized operators.

Foreseeable Misuse



Caution!

Never direct the produced compressed air towards persons.
Danger to life!

Oil is injected into the pressure rooms of the compressor.

Only use the produced compressed air for breathing or let it come in contact with foods, if it was treated beforehand.

This BOGE compressor is not explosion protected.

Do not operate in explosive areas or in a possibly explosive atmosphere!

Do not operate the compressor in rooms in which extreme dust, toxic or flammable vapours and gases may occur.

The following is not permitted:

- Compression of other media than those mentioned under intended use or compression of air loaded with contaminants.
- Exceeding the final compression pressure indicated on the type plate.
- Altering the safety devices and safety cladding or placing them out of operation.
- Removing or painting over signs and symbols on the compressor.
- Operation of the compressor by unauthorized or untrained persons.

Transport damage

BOGE does not accept any liability for breakage or transport damage. Please inspect the compressor immediately after delivery and direct damage claims to the last haulier – even when the packing is not damaged!

To safeguard claims against the haulier we recommend leaving the machine, devices and packing material in the same condition as they were in when the damage was detected.

In the event of any other complaints, please inform us within six days after arrival of the delivery.

Data on the type plate

Enter the data of your compressor from the type plate or enclosed data sheet in the illustration below. This will ensure that in the event of enquiries, you will always have the most important data to hand.

	
Type	_____
Year of construction	_____
Serial number	_____
F.a.d.	max. _____ m ³ /min
Final compression pressure	_____ bar
Motor speed	_____ min ⁻¹
Motor power	_____ kW
 Otto-Boge-Straße 1–7 · D-33739 Bielefeld · Telefon (05206) 601-0 Postfach 100713 · D-33507 Bielefeld · Fax (05206) 601-200 www.boge.com · info@boge.com	

Fig. 1.1: Data on the type plate

Service

Please do not hesitate to contact BOGE service if you have any questions. Please call:

Telephone: +49 5206 601-140

In the event of inquiries, always specify the following data of your compressor to prevent any delays:

- Type
- Year of manufacture
- Machine number

**Attention!**

Only BOGE service technicians or persons authorized by BOGE in writing may repair or alter the compressor during the warranty period. Otherwise all warranty claims will expire!

2.1 Technical data

Technical data for C 3 L...C 7 L Compressor assembly, part 1

Type		C 3 L	C 4 L	C 5 L	C 7 L
Dimensions					
– Width	[mm]	755	755	755	755
– Depth	[mm]	485	485	485	485
– Height	[mm]	492	492	492	492
Weight					
– silenced	[kg]	105	110	125	130
– super silenced	[kg]	–	–	–	–
Max. sound pressure level $[\pm 3 \text{ dB(A)}]$ accord. to DIN 45635, part 13					
– silenced / super silenced	[dB(A)]	61	62	67	68
Reference surface measure					
– silenced / super silenced	[dB(A)]	13	13	13	13
Sound power level					
– silenced / super silenced	[dB(A)]	74	75	80	81
Compressor					
max. final compression temperature	[°C]	110	110	110	110
Volume flow according to ISO 1217 appendix C at:					
– $p_{\text{max}} = 8 \text{ bar}$	[m ³ /min]	–	–	–	–
– $p_{\text{max}} = 10 \text{ bar}$	[m ³ /min]	0.240	0.340	0.545	0.728
– $p_{\text{max}} = 13 \text{ bar}$	[m ³ /min]	–	0.234	–	0.525
Drive motor					
Rated power	[kW]	2.2	3.0	4.0	5.5
Nominal speed 50 Hz	[min ⁻¹]	1500	1500	3000	3000
Protection type	IP	55	55	55	55
Design	IMB	35	35	35	35
ISO class		F	F	F	F
Electrical connection					
Mains voltage 1 Ph \sim ¹⁾	[V]	230	–	–	–
Frequency ¹⁾	[Hz]	50	–	–	–
Recommended fuse protection ^{2) 3)}	[A]	16	–	–	–
Mains voltage 3 Ph \sim ¹⁾	[V]	400	400	400	400
Frequency ¹⁾	[Hz]	50	50	50	50
Recommended fuse protection ^{2) 3)}	[A]	16	20	25	25

¹⁾ Standard equipment. Mains voltages and frequencies are specified on a plate in the switch cabinet.

²⁾ Only for 400 V / 50 Hz. The fuse values change in the case of other mains voltages and frequencies.

³⁾ Use fuse gL – gG or circuit-breaker with C-characteristic only.

Technical data for C 3 LR...C 7 LR Compressed air system, 90-litre-receiver, 10 bar, part 1
C 3 LDR...C 7 LDR Compressed air centre, 270-litre-receiver, 10 bar, part 1

Type		C 3 LR	C 4 LR	C 5 LR	C 7 LR	C 3 LDR	C 4 LDR	C 5 LDR	C 7 LDR
Dimensions									
– Width	[mm]	1185	1185	1185	1185	1725	1725	1725	1725
– Depth	[mm]	550	550	550	550	675	675	675	675
– Height	[mm]	965	965	965	965	1165	1165	1165	1165
Receiver volume	[l]	90	90	90	90	270	270	270	270
Weight									
– silenced	[kg]	175	180	195	200	245	250	265	270
– super silenced	[kg]	–	–	–	–	–	–	–	–
Max. sound pressure level [±3 dB(A)] accord. to DIN 45635, part 13									
– silenced / super silenced	[dB(A)]	61	62	67	68	61	62	67	68
Reference surface measure									
– silenced / super silenced	[dB(A)]	13	13	13	13	13	13	13	13
Sound power level									
– silenced / super silenced	[dB(A)]	74	75	80	81	74	75	80	81
Compressor									
max. final compression temperature	[°C]	110	110	110	110	110	110	110	110
Volume flow according to ISO 1217 appendix C at:									
– p _{max} = 8 bar	[m ³ /min]	–	–	–	–	–	–	–	–
– p _{max} = 10 bar	[m ³ /min]	0.240	0.340	0.545	0.728	0.240	0.340	0.545	0.728
– p _{max} = 13 bar	[m ³ /min]	–	–	–	–	–	–	–	–
Drive motor									
Rated power	[kW]	2.2	3.0	4.0	5.5	2.2	3.0	4.0	5.5
Electrical power intake dryer	[kW]	–	–	–	–	0.19	0.21	0.21	0.28
Nominal speed 50 Hz	[min ⁻¹]	1500	1500	3000	3000	1500	1500	3000	3000
Protection type	IP	55	55	55	55	55	55	55	55
Design	IMB	35	35	35	35	35	35	35	35
ISO class	F	F	F	F	F	F	F	F	F
Electrical connection									
Mains voltage 1 Ph ~ ¹⁾	[V]	230	–	–	–	230	–	–	–
Mains voltage dryer ¹⁾	[V]	–	–	–	–	230	–	–	–
Frequency ¹⁾	[Hz]	50	–	–	–	50	–	–	–
Recommended fuse protection ^{2) 3)}	[A]	16	–	–	–	16	–	–	–
Mains voltage 3 Ph ~ ¹⁾	[V]	400	400	400	400	400	400	400	400
Mains voltage dryer ¹⁾	[V]	–	–	–	–	230	230	230	230
Frequency ¹⁾	[Hz]	50	50	50	50	50	50	50	50
Recommended fuse protection ^{2) 3)}	[A]	16	20	25	25	16	20	25	25

¹⁾ Standard equipment. Mains voltages and frequencies are specified on a plate in the switch cabinet.

²⁾ Only for 400 V / 50 Hz. The fuse values change in the case of other mains voltages and frequencies.

³⁾ Use fuse gL – gG or circuit-breaker with C-characteristic only.

Technical data for C 4 LR, C 7 LR Compressed air system, 160-litre-receiver, 13 bar, part 1
C 4 LDR, C 7 LDR Compressed air centre, 350-litre-receiver, 13 bar, part 1

Type		C 4 LR	C 7 LR	C 4 LDR	C 7 LDR
Dimensions					
– Width	[mm]	1445	1445	1755	1755
– Depth	[mm]	550	550	720	720
– Height	[mm]	1080	1080	1215	1215
Receiver volume	[l]	160	160	350	350
Weight					
– silenced	[kg]	230	250	300	320
– super silenced	[kg]	–	–	–	–
Max. sound pressure level $[\pm 3 \text{ dB(A)}]$ accord. to DIN 45635, part 13					
– silenced / super silenced	[dB(A)]	62	68	62	68
Reference surface measure					
– silenced / super silenced	[dB(A)]	13	13	13	13
Sound power level					
– silenced / super silenced	[dB(A)]	75	81	75	81
Compressor					
max. final compression temperature	[°C]	110	110	110	110
Volume flow according to ISO 1217 appendix C at:					
– $p_{\text{max}} = 8 \text{ bar}$	[m ³ /min]	–	–	–	–
– $p_{\text{max}} = 10 \text{ bar}$	[m ³ /min]	–	–	–	–
– $p_{\text{max}} = 13 \text{ bar}$	[m ³ /min]	0.234	0.525	0.234	0.525
Drive motor					
Rated power	[kW]	3.0	5.5	3.0	5.5
Electrical power intake dryer	[kW]	–	–	0.21	0.28
Nominal speed 50 Hz	[min ⁻¹]	1500	3000	1500	3000
Protection type	IP	55	55	55	55
Design	IMB	35	35	35	35
ISO class		F	F	F	F
Electrical connection					
Mains voltage 3 Ph \sim ¹⁾	[V]	400	400	400	400
Mains voltage dryer ¹⁾	[V]	–	–	230	230
Frequency ¹⁾	[Hz]	50	50	50	50
Recommended fuse protection ^{2) 3)}	[A]	20	25	20	25

¹⁾ Standard equipment. Mains voltages and frequencies are specified on a plate in the switch cabinet.

²⁾ Only for 400 V / 50 Hz. The fuse values change in the case of other mains voltages and frequencies.

³⁾ Use fuse gL – gG or circuit-breaker with C-characteristic only.

Technical data for C 3 L...C 7 L Compressor assembly / Compressed air system, part 2
C 3 LDR...C 7 LDR Compressed air centre, part 2

Type		C 3 L C 3 LR C 3 LDR	C 4 L C 4 LR C 4 LDR	C 5 L C 5 LR C 5 LDR	C 7 L C 7 LR C 7 LDR
Oil filling quantity					
Total oil filling quantity	[l]	4	4	4	4
Oil topping up quantity between min. + max.	[l]	1	1	1	1
Intake air temperature					
– min.	[°C]	5	5	5	5
– max.	[°C]	40	40	40	40
Cooling air requirement					
– free-standing installation	[m ³ /h]	800	1200	1600	2000
– with supply and exhaust	[m ³ /h]	–	–	–	–
– free ventilator pressure	[Pa]	–	–	–	–
– free ventilator pressure	[mm WC]	–	–	–	–
Operating pressure values ¹⁾ (factory settings)					
– p _{max} = 8 bar: Switch-off press. p _{max}	[bar]	–	–	–	–
Switch-on press. p _{min}	[bar]	–	–	–	–
– p _{max} = 10 bar: Switch-off press. p _{max}	[bar]	10	10	10	10
Switch-on press. p _{min}	[bar]	9	9	9	9
– p _{max} = 13 bar: Switch-off press. p _{max}	[bar]	–	13	–	13
Switch-on press. p _{min}	[bar]	–	12	–	12
Safety valve					
Activation pressure at:					
– p _{max} = 8 bar	[bar]	11	11	11	11
– p _{max} = 10 bar	[bar]	11	11	11	11
– p _{max} = 13 bar	[bar]	14	14	14	14

¹⁾ Compressors for other operating pressures $P_{min} = P_{max} - 1$ bar.

2.2 Function description

Function principle of the air end

The air end operates according to the displacement principle. In the housing, the main and secondary screws are driven by means of an electric motor.

Both screws have screw-shaped profiles, intermeshing without contact. Together with the housing wall, these screws form chambers which gradually reduce in size, seen in air flow direction.

Rotation of the rotors causes the air taken in to be compressed to the final pressure in the chambers.

During compression oil is continuously injected into the air end. This having a cooling, sealing and lubricating function.

Air circuit

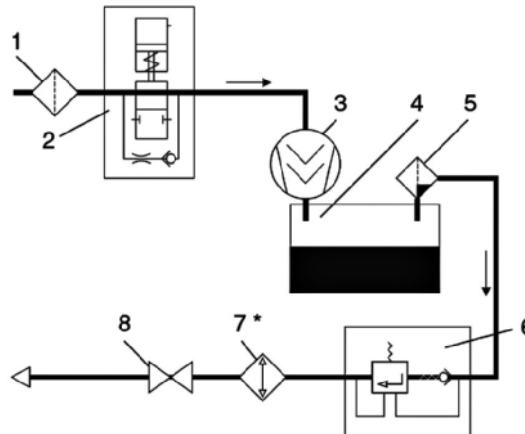

Fig. 2.1: Components of the air circuit

1 Intake filter

The intake filter cleans the air suctioned by the air end.

2 Intake regulator

The intake regulator opens (load operation) or closes (idling operation or standstill) the suction line depending on the operating condition of the compressor.

3 Air end

The air end compresses the sucked in air.

4 Compressed air/oil receiver

The compressed air separates from the oil under the force of gravity in the compressed air/oil receiver.

5 Oil separator

The oil separator separates the residual oil contained in the compressed air.

6 Minimum pressure check valve

The minimum pressure check valve does not open until the system pressure has increased to 3.5 bar. This causes a rapid build-up of the system pressure and ensures lubrication in the starting phase. Once the compressor has been switched off, the check valve prevents the compressed air from flowing back out of the mains line.

7* Compressed air after-cooler (air cooled)

The compressed air is cooled in the compressed air after-cooler, causing the water contained in the air to condensate.

8 Stop valve

The screw compressor may be isolated from the mains by means of the stop valve.

* Optionally for receiver systems without refrigeration compressed air dryers

Oil circuit

The oil injected into the air end has the following functions:

- It dissipates the compression heat (cooling)
- It seals the gaps between the screws and between screws and housing
- It lubricates the bearings

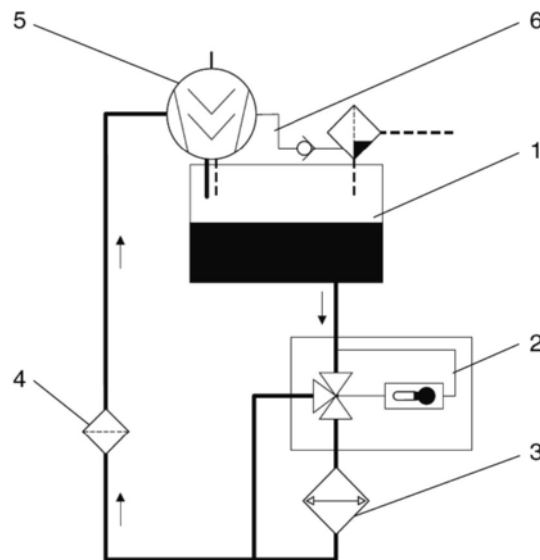

Fig. 2.2: Components of the oil circuit

1 Compressed air/oil receiver

The oil separated from the compressed air through the force of gravity collects in the compressed air/oil receiver.

The system pressure forces it out of the receiver into the air end.

2 Thermostatic oil control valve

Depending on the oil temperature, the thermostatic oil control valve either allows the oil to pass through the oil cooler or through a bypass (e.g. in the starting phase).

Thus the oil constantly maintains its optimum operating temperature.

3 Oil cooler (air or water cooled)

The oil cooler cools down the hot oil to operating temperature.

4 Oil filter

The oil filter traps impurities in the oil.

5 Air end

The injected oil returns to the compressed air/oil receiver together with the compressed air. There, it is separated through the force of gravity.

6 Drainage line

The air end suctions the residual oil which collects in the oil separator back into the oil circuit via a drainage line.

2.3 Compressor control

Network pressure

For the compressor, the pressure downstream of the check valve is termed network pressure. The control system switches the compressor on and off during operation depending on the network pressure.

Operating states

All screw compressor controls are based on three basic operating states:

1. Load operation

- The compressor delivers its maximum amount of compressed air.
- It consumes its maximum energy.

2. Idling operation

- The compressor runs but does not deliver any compressed air.
- It consumes approx. 75% less energy than in load operation.
- When compressed air is required, it switches to load operation without delay.
- Idling operation reduces switching frequencies which can damage the drive motor, and reduces wear of the system.

3. Standstill ready for operation

- The compressor is standing still but ready for operation.
- When compressed air is required, it switches automatically to load operation.

Operating modes

The two most important operating modes are achieved by combining the three operating states:

1. Intermittent operation

In intermittent operation the energy balance is perfect.

- The compressor operates in load operation.
- Upon reaching the switch-off pressure p_{\max} the compressor switches to standstill. It does not consume any energy.
- Once the pressure has dropped to the switch-on pressure p_{\min} the compressor switches back to load operation.

2. Continuous operation

Continuous operation limits the drive motor switching cycles and reduces wear to the system.

- The compressor operates in load operation.
- Upon reaching the switch-off pressure p_{\max} the compressor switches to idling operation.
- Once the pressure has dropped to the switch-on pressure p_{\min} the compressor switches from idling operation back to load operation.

Short operating times

**Attention!**

During short operating times, the compressor does not reach its operating temperature. It operates below the dew point. The generated condensate mixes with the oil. The lubricating ability of the oil is reduced. This leads to damage on the air end.

It is of utmost importance to consult BOGE, if you operate your system with short operating times.

2.4 Control devices

Operating pressure transmitter

The operating pressure transmitter enables an operation of the compressor within the set switching limits.

Switch-on pressure p_{\min}

If the supply pressure drops to the set switch-on pressure p_{\min} , the compressor switches on.

Switch-off pressure p_{\max}

If the supply pressure increases to the switch-off pressure p_{\max} , the compressor either switches off (intermittent operation) or switches to idling operation (continuous operation).

2.5 Safety and monitoring devices

General

The safety devices guarantee a high degree of operational safety, in connection with the BOGE monitoring system.

When one of the safety devices responds, the control system reacts as follows:

- The compressor is immediately switched off.
- A flashing fault number in the left field of the display indicates the cause of the fault.

**Caution: Risk of injury!**

Do not operate the compressor without built-in safety devices.
Do not dismantle the safety devices or put them out of operation.

The following monitoring devices are standard for BOGE control systems:

Safety valve

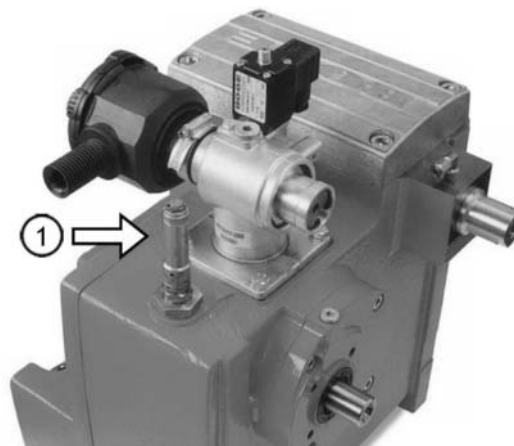

The safety valve 1 on the compressed air/oil receiver prevents the maximum admissible pressure being exceeded.

Fig. 2.3: Safety valve



Caution: Risk of injury!

When the maximum pressure is exceeded (e.g. incorrect setting of the operating pressure value), the entire delivery volume of the compressor is ejected.

Safety temperature limiting device

The safety temperature limiting device switches off the compressor once the maximum admissible final compression temperature has been reached. The compressor does not switch on when dropping below the minimum temperature.

- Rectify the fault.
- Acknowledge fault by pressing **ENTER-key** .
- Switch on the compressor (**ON-button**).

Monitoring the drive motor

The drive motor is monitored by PTC resistors.

3.1 Transport and storage

General

Please observe the generally accepted safety and accident prevention regulations when transporting the compressor. BOGE accepts no liability for damage caused by improper transport!



Attention!

The transport of the compressor may only be carried out by adequately instructed and authorized personnel!

The capacity of the lifting gear (lifting cart or forklift truck) must correspond at least to that of the compressor (see Technical Data)!

Mind the position of the mass centre prior to lifting the compressor! The position of the mass centre is specified both in the attached dimensioned drawing and on the packing of the compressor.

The compressor is delivered filled with oil. Do not tilt during transport!

Transport possibilities

Forklift truck or lifting cart transport

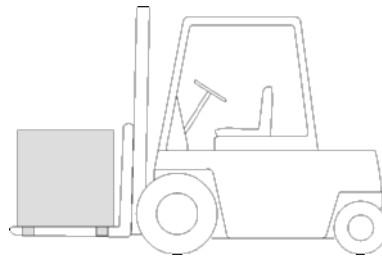

Ensure that the forks are underneath the base frame of the compressor (see illustration).

See below if there is no base frame (crane transport).

Fig. 3.1: Transport with forklift truck

Crane transport

**Attention!**

Do not subject the safety cladding to force during transport. Protect the compressor using wooden spacers (see arrows in the following illustrations). Remove the transport timbers.

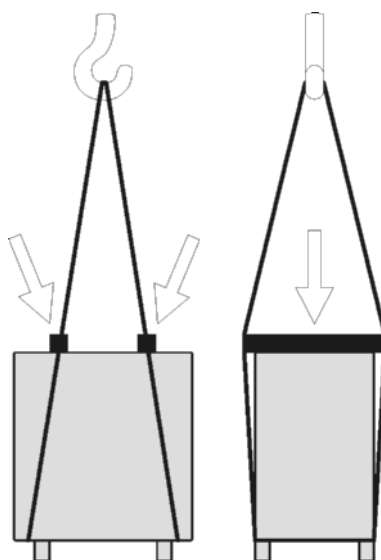

Only use suitable transport slings having a minimum length of approx. 8 metres.

Position the slings at the ends underneath the base frame of the compressor.

Fig. 3.2: Crane transport

Intermediate storage

In case the compressor is not installed immediately after delivery, it has to be stored at a sheltered location. It must be ensured that during the intermediate storage neither dust nor humidity can penetrate.

**Note!**

In case of an intermediate storage please observe the specifications and directions as to permissible environmental impacts (see chapter „3.2 Compressor room: Installation, maintenance conditions and application for compressed air receivers arranged below or separately“).

In case of a careless storage we assume no liability for consequent damages!

In the event of an extended intermediate storage you should consult BOGE-Service.

Please observe the directions for commissioning after an extended standstill (see chapter „3.5 Commissioning“) if the intermediate storage takes longer than two months.

3.2 Compressor room

Installation, maintenance conditions and application for compressed air receivers arranged below or separately



Caution!

- Protect compressed air receivers against damage through mechanical effects (e.g. falling objects).
- Operate the compressed air receiver and its equipment from a safe location.
- Adhere to safety areas and safety clearances.
- Ensure that the compressed air receiver stands securely. It must not shift or tilt due to external forces. This also includes the additional weight during a pressure test!
- The compressed air receiver **must not** be bolted to the base.
- Ensure that the compressed air receiver is easily accessible from all sides (for recurring tests). For the necessary operating and maintenance areas have a look at the attached dimensioned drawings.
- Ensure that the factory label is clearly visible.
- Ensure that compressed air receivers are adequately protected against corrosion.
- Only use the compressed air receiver for compressors operating with cut-in and cut-out mode if the pressure fluctuation range amounts to $\Delta p \leq 20\%$ of the maximum operating pressure.

Installation surface

A level industrial floor without foundation is adequate for the installation of the compressor. No special fastening elements are required.

Fire protection

The following applies to rooms in which compressors with oil injection cooling are to be installed:



Caution!

- For compressors with motor ratings **exceeding 40 kW**, ensure that the compressor room is equipped with special fire protection.
- Install compressors with motor ratings **exceeding 100 kW** in a separate fire protected room.

Requirements of fire protected compressor rooms:

- Walls, ceilings, floor and doors must be designed in **fire protection class F30** or higher.
- Flammable liquids must never be stored in the compressor room.
- The floor around the compressor must be made of non-flammable material.

- Leaking oil must not spread out over the floor.
- No inflammable materials must be located within a radius of at least 3 metres around the compressor.
- No inflammable machine parts, such as cable ducts, may run overhead of the compressor.

Sound protection

Only install compressors in workrooms if the sound pressure level of their measuring surfaces does not exceed 85 dB (A).

Admissible environmental influences

The compressor room must be clean, dry, cool and free of dust.

Admissible ambient temperatures

Maximum ambient temperature: + 40°C

Minimum ambient temperature: + 5°C



Attention!

Nonobservance of the admissible ambient temperature may lead to the following problems:

- The compressor will switch off when the admissible final compression temperature is exceeded or gone below.
- Pipe lines and valves will freeze up at low temperatures.
- Damage due to reduced lubricating ability of the compressor oil.

Measures to be taken to ensure that admissible ambient temperatures are observed:

- Avoid any pipe lines or units radiating heat in the vicinity of the compressor, or insulate them well.
- Never install the compressor in the cooling air flow of other machines.
- Provide the supply air openings with adjustable louvres to ensure that the minimum temperature is not gone below in winter.
- Use of anti-freeze function (only in mode: Ready for operation).

Ventilation

If the following instructions are not observed, the admissible final compression temperature may be exceeded. In this case, the compressor will switch off automatically.



Caution!

Arrange the compressor intake openings or ducts in such a way, that dangerous admixtures (e.g. explosive or chemically unstable materials) cannot be drawn in.

Ventilation openings (free-standing installation)

- Arrange supply air openings close to the floor.
- Arrange exhaust air openings in the ceiling or at the top of the wall.
- The required cross sections for the supply openings (as well as for the flaps and weather protection grids) are indicated in the table.

Ventilators

Ensure that the heated exhaust air is not taken in again.
If necessary, the heated air must be extracted by ventilators.

To ensure perfect cooling even at higher temperatures in the summer, the ventilators must be designed as follows:

- The ventilator capacity must be rated approx. 10 – 15% higher than the sum of the cooling air quantity required for all machines operated in the room (VDMA Code of Practice sheet 4363 "Ventilation of compressor rooms").
- For a free-standing installation, the cooling air requirement specified in the table corresponds to the required ventilator capacity.

Cooling air requirement

Please refer to the following table for the cooling air requirement and size of the supply air openings for your compressor. Ensure that flaps and weather protection grids have the necessary free cross section. We generally recommend contacting a specialist company for performing the duct construction work and planning.

Type	Drive rating [kW]	* Cooling air requirement for free standing unit [m ³ /h]	Necessary inlet opening for free standing unit [m ²]
C 3 L / C 3 LR / C 3 LDR	2.2	800	0.10
C 4 L / C 4 LR / C 4 LDR	3.0	1200	0.20
C 5 L / C 5 LR / C 5 LDR	4.0	1600	0.20
C 7 L / C 7 LR / C 7 LDR	5.5	2000	0.25

* For the cooling air requirements the basis is a 4°C temperature difference between room and outside temperature

Tab. 3.1: Cooling air requirement, necessary aperture dimensions

Condensate disposal

The air taken in contains water in form of vapour, which turns into condensation during compression.



Attention!

The condensate contains oil. Never lead it into the public sewage system without prior treatment.
Strictly observe the effluent disposal laws of your local authorities.

Oil-water separator

The **BOGE-oil-water-separator** separates the oil from the condensate. The cleaned water may be fed directly into the public sewage system. The oil is collected in a separate container. Dispose of the oil according to environmental regulations.
If, due to special operating conditions, the oil should emulsify, use an emulsion cracking plant.

3.3 Installation

General

BOGE compressor units are supplied ready for connection. Only the work described in the following paragraphs needs to be carried out during the installation.



Caution!

Only have the installation work carried out by appropriately trained persons or specialists.

Lay out all energy supply lines in a trip-proof and barrier-free manner so that potential accidents can be avoided!

Prior to delivery, each compressor is subjected to a trial run at the factory. It is carefully tested and set. However, possible transport damage cannot be excluded.

- Please inspect the compressor immediately after delivery and direct damage claims to the last haulier – even when the packing is not damaged! To safeguard claims against the haulier we recommend leaving the machine, devices and packing material in the same condition as they were in when the damage was detected.
- Prior to commissioning, check the compressor for external damage.
- Observe the compressor very closely during commissioning and the following trial run.
- If malfunctions occur, switch off the compressor immediately and inform the BOGE-Service.

Checking the delivery scope

The delivery scope depends on your order.

Prior to commissioning, please check whether all required parts have been provided. Please check the order confirmation for any possible accessory equipment.

- The delivery scope includes the following component parts:
- Operating instructions
- Electric circuit diagram (in the compartment of the switch cabinet)
- List of electrical equipment (in the compartment of the switch cabinet)
- Oil drainage hose
- Head nut (in the compartment of the switch cabinet)
- Spare parts list

Installing the compressor

- Remove the packing material on and in the compressor.
- Install compressor and align horizontally.
The compressor must stand firmly on the ground on all feet.
- For compressor assemblies of the series C 3 L to C 7 L the operating height of the control has to be 400 mm according to EN 60204 400.
- For this reason the compressor assembly has to be installed on a console or pedestal (on site).

- The compressors have to be installed in such a manner that an ergonomically convenient operation from the operator's stand is guaranteed.
- The local specifications of the EN 60204 regulations always have to be complied with.

Connecting the compressor to the compressed air network

- Connect the compressor to the compressed air network or a compressed air receiver.
- For this, use a BOGE high pressure hose.
For pneumatic connection see dimensioned drawing.



Note!

Do not install a check valve in the pressure line.
The compressor is already equipped with a check valve.

Checking the oil level

BOGE compressors are supplied with a complete oil filling.
Prior to commissioning/start up, check the oil level as described in chapter "Maintenance".

3.4 Electrical connection



Warning: Voltage!

Ensure that work on the electrical equipment of the compressor is only carried out by authorized electricians.

When connecting to the power supply, observe the valid VDE, DIN and EVU regulations or the local safety regulations.

Also observe the regulations of your local power supply company regarding the load rating of your power supply.

Mains disconnecting device

According to accident prevention regulation VBG 5, § 12, the customer is responsible to provide the following safety measures:

Each compressor plant has to be equipped with a power disconnecting device according to DIN EN 60204-1:2007.

Please refer to the "Technical data" for the design and fuse rating.

Rated voltage

The data of your mains (operating voltage, control voltage, type of current, frequency, ...) must coincide with the data on the type plate on the switch cabinet.

In the event of deviations, please contact the BOGE service or your supplier.

Connecting the leads

- Check to ensure that all terminals in the switch cabinet are firmly tightened. If necessary, retighten the screw connections.
- Guide the lead cable through the PG screw connection.
- Connect the leads L1, L2, L3, N, Pe (PEN) firmly to the power supply terminal.
A clockwise rotational field must be created.
- Retighten the electrical connections after the first 50 operating hours.

**Caution: Risk of injury!**

Prior to any work on the compressor:

- Press Emergency Stop button, open mains disconnection device and secure against unintentional switch on by means of a padlock.
- Check to ensure that all conducting machine parts are voltage free.
- Depressurize all areas under pressure.

Never omit a single safety step! Otherwise, you will risk injuries due to restarting, electric shock or self-releasing parts.

**Caution!**

With an activated automatic restart (Auto-Restart) the compressor may restart automatically after a voltage failure.

Prerequisite: The network pressure is lower than the set cut-in pressure of the operating switch and it was already switched on before the mains failure – green indicator lamp = ON.

3.5 Commissioning

**Note!**

We recommend the drawing up of a commissioning certificate in which the test results during the commissioning process can be listed up.

**Caution: Risk of injury!**

The commissioning may only be carried out by experienced and authorized qualified personnel!

Always wear protective gloves when working on the compressor to avoid bruising of fingers or hands while opening or closing components!

Check installation requirements

**Attention!**

Make sure that the compressor is installed according to the installation requirements!

List up the test results in the commissioning certificate.

Checking the rotational direction

**Attention!**

Always check the rotational direction of the drive motor prior to commissioning/initial start up.

Even brief operation in the wrong direction of rotation (more than approx. 5 seconds) may cause total destruction of the air end!

List up the test results in the commissioning certificate.

**Caution!**

Ensure that the rotational direction coincides with the rotational direction arrow on the air end.

- Close mains disconnecting device.
- Switch the compressor on and immediately off again to check the rotational direction.

Changing the rotational direction

**Caution: Risk of injury!**

Press Emergency Stop button, open mains disconnection device and secure against unintentional switch on by means of a padlock.

- Interchange two phases (L1, L2 or L3) in the power cable.

Check compressed air outlet for tightness

**Caution: Risk of injury!**

Work on the compressed air system may only be carried out by experienced and authorized qualified personnel!

Always wear protective clothing and goggles!

Immediately after having switched on the machine the connection of the compressed air outlet must be checked for tightness!

Make sure to observe an appropriate safety distance during the inspection!

- Close mains disconnecting device.
- To conduct the inspection switch on the compressor and check the compressed air outlet for tightness.
- Switch off compressor.



Caution: Risk of injury!

Press Emergency Stop button, open mains disconnection device and secure against unintentional switch on by means of a padlock.

- If necessary, have leakages repaired by skilled qualified personnel.

- List up the test results in the commissioning certificate.

Opening the stop valves

Open ball valve on the compressor delivery.

Checking for leaks



Caution: Risk of injury!

In case of leakages in the oil circuit there is a certain danger to slip and fall because of oil spills!

Have all connections of the oil circuit checked for leakages by authorized qualified personnel!

During the inspection slip-resistant safety shoes and protective clothing are obligatory!

Undertake the following to prevent leaks:

- Check screw connection of the lines and retighten, if necessary.

Conduct trial run

- Close mains disconnecting device.
- Switch on the compressor using the ON key. The compressor starts.
- When the factory-set switch-off pressure is reached, the compressor cuts off automatically.
- Check network pressure on control display. If necessary, reset operating pressure (pressure target value).
- The compressor is ready for operation.

Switch off the compressor after a trial run of several hours under maximum load.

List up the test results in the commissioning certificate.

Commissioning following extended stoppages

If an extended stoppage is scheduled, you should contact BOGE-Service beforehand.

Following an extended stoppage of more than 2 months, fill a small amount of oil in the suction controller prior to starting the compressor.



Attention!

Only fill the suction controller with the grade of oil used to operate the compressor.

Never mix different oil grades and brands.



Caution: Risk of injury!

Press Emergency Stop button, open mains disconnection device and secure against unintentional switch on by means of a padlock.



- Unscrew the plug on the suction controller 1.
- Fill approx. 1/4 l compressor oil into the suction controller.
- Reclose the controller using the plug.
- Turn compressor stage at the shaft by hand 5- to 10 times to spread the oil evenly.

Fig. 3.3: Suction controller

Refrigeration compressed air dryer

Before commissioning the refrigeration compressed air dryer read attached operating instructions.



Caution: Risk of injury!

Observe all safety notes specified in the attached operating instructions when working with coolants!

3.6 Dismantling

**Note!**

To avoid dangers when dismantling the compressor please consult your BOGE Service:

Telephone: +49 5206 601-140

**Caution!**

Dismantling of the compressor may only be carried out by experienced and authorized qualified personnel!

Make also sure to observe all information in the attached operation instructions as to a safe dismantling of the refrigeration compressed air dryer and a secure disposal of the coolant!

**Warning: Voltage!**

All work on the electrical installation may only be carried out by authorized and skilled electricians!

Prior to starting the work the power cable to the switch cabinet must be disconnected from the mains and secured against unintentional switching on!

4.1 General

The tables on the following pages give information on the possible causes of operating faults and measures for their rectification (please also refer to operating instructions of the compressor control).



Caution!

Ensure that any work required to rectify faults is only carried out by qualified personnel or specialists.

Ensure that components which have a safety function are only set, repaired or exchanged by BOGE Service!





Please contact BOGE-Service at the following telephone number, if you have any questions.

Telephone: +49 5206 601-140

4.2 General faults

Fault	Possible cause	Rectification
No quantity delivered, no pressure build-up, max. pressure 0.5 bar	System components in the compressor are leaking	Check oil and compressed air lines inside the compressor; tighten and/or reseal screw connections, if necessary
	Minimum pressure valve is defective	Close ball valve and check whether pressure builds up; if so, open ball valve again immediately; replace minimum pressure valve
	Electromagnetic venting valve does not close	Check solenoid valve and replace, if necessary
	Suction controller does not open	Suction controller or solenoid valve is defective; check and replace, if necessary

Compressor system does not start up 	No electric power to compressor	Check electrical connection
	Fuses are defective	Check the mains and control fuses, replace if necessary
	Machine has not vented perfectly	Check venting valve and replace, if necessary
	Voltage fluctuations in the electrical mains power	Ensure constant voltage in accordance with IEC 38
	Compressor oil is very viscous due to low ambient temperature	Heat up the compressor system (additional heater available as an option)

Fault	Possible cause	Rectification
Oil in suction filter 	Minimum pressure non-return valve is leaking	Check the minimum pressure check valve and replace, if necessary
	Suction controller is leaking	Check the suction controller and replace, if necessary
	Cut-out performed by emergency-off switch	Cut-out normally via O -key
Excessive oil consumption 	Drain line is blocked	Dismantle and clean drain line
	Defective oil separator element	Check oil separator and replace, if necessary
	Excessive oil filling	Drain off oil
Safety valve blows 	Operating pressure target value maladjusted	Set operating pressure to maximum permissible pressure of the screw compressor
	Defective safety valve	Replace safety valve
System pressure does not decrease when switching off 	Venting valve does not open	Check venting valve and replace, if necessary
	Check valve is leaking	Check the valve and replace, if necessary

5.1 Safety instructions



Caution!

Ensure that maintenance work is only carried out by specialists or appropriately trained persons.

- Prior to starting any maintenance work, always stop the compressor as described in these operating instructions before removing any safety cladding or safety devices. Refit the safety cladding or safety devices immediately upon completion of the maintenance work.
- Heavy components may only be lifted up by various persons in due consideration of the local industrial safety regulations.
- Only use original spare parts, compressor oils and operating materials released by BOGE for the maintenance work.
- With an activated automatic restart (Auto-Restart) the compressor may restart automatically after a voltage failure.
Prerequisite: The net pressure is lower than the set switch-on pressure.

**Caution: Risk of injury!**

Always adhere to the prescribed operating method described below for all maintenance work. Never omit a single safety step!

Otherwise you will risk injury from restarting, electric shock or parts which may fly off.

Prior to all maintenance work:

1. Switch off the compressor using the OFF button.
2. Press Emergency Stop button.
3. Press Emergency Stop button, open mains disconnection device and secure against unintentional switch on by means of a padlock.
4. Fix a warning label to the control and fill in the name of the person responsible who is authorized to switch on the machine again.
5. Check to ensure that all machine elements are definitely currentless.
6. Prior to starting work let cool down all hot components of the compressor to 50°C.
7. Separate the compressor from the compressed air network by closing the ball valve at the compressed air outlet.
8. Vent the compressor.
To do so, open the safety valve on the combined compressed air-oil receiver as follows:
 - Turn the knurled nut anticlockwise until you can feel a resilient resistance.
 - Turn the knurled nut a little further.
Any possibly existing air will escape.
The system pressure gauge will indicate a pressure of 0 bar.
 - Once the residual air has completely escaped from the system, firmly retighten the knurled nut.
9. Remove all safety cladding necessary to perform the maintenance work.

Once the maintenance work has been concluded:

10. Reattach all removed safety cladding.
11. Open the ball valve at the compressed air outlet.
12. Prior to switching on again, check whether anyone else is working on the compressor!
13. Remove warning sign not until then and release mains disconnecting device.
14. Unlock Emergency Stop button.

5.2 General

Maintenance through BOGE customer service

Have BOGE service check your compressor every 3.000 operating hours or annually.

**Note!**

Maintenance agreement!

Enter into a maintenance agreement with BOGE.

BOGE service will carry out the proper maintenance on your compressor at regular intervals. This guarantees maximum safety and reliability of your compressed air supply.

Review of regular maintenance work

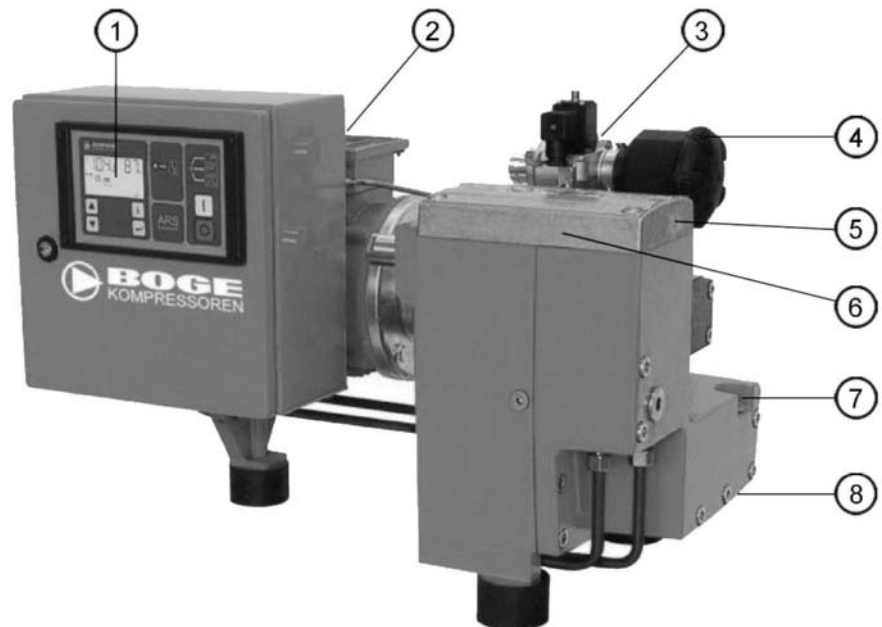

Fig. 5.1: Review of regular maintenance work

- 1 Check / adjust pressure
- 2 Clean oil cooler
- 3 Top up oil in the suction controller after an extended down time
- 4 Check suction filter
 - Clean / Change filter cartridge
- 5 Change oil filter
- 6 Change oil separator
- 7 – Check oil level
 - Top up oil
- 8 Change oil

Maintenance intervals

The maintenance intervals specified in the table are based on average operating and ambient conditions.

Extreme conditions may require shorter maintenance intervals.

**Note!**

Note down any maintenance work in the table on the last page. This will facilitate trouble shooting for Boge service.

**Attention!**

Check monthly if all screw connections on the compressor are fully tightened.

Oil change:

Please change oil and replace oil filter and nozzle with dirt catch after the first 500 operating hours!

Maintenance work	Maintenance intervals in operating hours ¹⁾					Page
	weekly, monthly	1.000 annually	1.500 annually	3.000 annually	9.000 every 2 years	
General maintenance work						
Check final compression temperature (set point value: 70...100°C)	w					Control
Check compressor for leaks				X		–
Check system relief on system pressure gauge (22) (set point value: 0 – 1.5 bar)	w					Control
Check function of EMERGENCY STOP button	m					–
Clean oil cooler			X			51
Draining off condensate from compr. air receiver	w					–
Check automatic condensate drainage	w					–
Check if electrical connections are tightened			X			–
Air circuit						
Check and if necessary clean suction filter	m					43
Change suction filter cartridge				X		44
Check safety valve				X		52
Replace minimum pressure valve (wearing parts set)				X		–
Replace suction controller					X	–
Oil circuit						
Check oil level and top up as required ²⁾		X				45
Change oil separator ²⁾				X		47
Change oil filter ²⁾				X		46
Change oil ²⁾					X	48
Replace oil regulator (wearing parts set)				X		–
Replace nozzle with dirt catch				X		–
Drive						
Lubricate drive motor bearings	Drive motors with permanent lubrication					44
Replace motor bearing	Depending on mains frequency: 50 Hz 10.000 operating hours 60 Hz 8.000 operating hours					

¹⁾ If the compressor is not often used, undertake the maintenance according to the specified intervals (weekly/monthly/annually) depending on the number of operating hours.

²⁾ The specified intervals only apply when BOGE compressor oil **Syprem 8000 S** is used! The service life may differ depending on the ambient temperature. In this case have the oil analyzed by your BOGE service!

Tab. 5.1: Maintenance intervals

General information concerning the lubricants used



Caution: Risk of injury!

Oil presents a potential danger to health and environment due to their additives.

- Avoid contact with skin and eyes.
Wear protective gloves made of resistant synthetic material.
Wash yourself thoroughly after contact with oils.
- Do not inhale the fumes or mist.
- Protect your environment.
Ensure that no oil is spilt.
- Fire, naked flames and smoking is strictly prohibited when handling oil.

We recommend using only oil according to the following specification:

- Viscosity range of 55 mm²/s at 40°C.
- Minimum viscosity at 100°C of 8 mm²/s.
- Maximum viscosity at 0°C of 1.000 mm²/s.
- Failure load stage 10, FZG-Test, DIN 51 354-02/ ISO DIS 14 635-1.
- Test Method A/8,3/90 10.
- Excellent oxidation stability: Meets requirements of Pneurop oxidation test.
- Antifoam – additives.
- Additives to prevent residue formation.
- Compatibility with all materials which are resistant to mineral hydrocarbons, e.g. Neoprene, NBR, FPM, PTFE, acrylic and epoxy resin paints, nylon (polyamide) and PVC.
- Flash point (DIN ISO 2592) > 230°C.
- Excellent demulsifying properties.
- Additives for corrosion protection of metallic surfaces.
- Excellent oxidation stability: Rotating bomb oxidation Test (ASTM D 2272) higher than 2,400 minutes.
- Meets VDL requirements DIN 51 506 (including Pneurop test).
- Or you use BOGE compressor oil **Syprem 8000 S**.
The stated maintenance intervals refer to the use of **Syprem 8000 S** only.
- **Syprem 8000 S** can be purchased from BOGE retailers.
- Never mix different oil types and brands. The additives may be incompatible. It may lead to foam formation, premature aging or loss of lubricating ability.

Disposal of used operating material



Attention!

The handling and disposal of mineral oils is subject to legal regulations. It is an offense not to ensure correct and safe disposal of old oil!

Please instruct one of the known service companies to dispose of used operating materials or deliver them to an authorized disposal point.

Observe the following points when disposing of old oil:

- Never mix the oil with other material or liquids.
- Used oil filters and oil separator cartridges require special waste treatment and must be kept separate from normal waste!

Pressure hoses



Caution!

Risk of injury and damage to compressor due to obsolete pressure hoses!

Never use pressure hoses beyond the prescribed service life!

Check hoses and connections regularly for leakages! Check the service life of the hoses and replace them in due time!

As replacement only use original spare parts released by BOGE!

Used pressure hoses are not permitted as a replacement!

Spare and wearing parts



Caution!

Only use original spare parts, compressor oils and operating materials released by BOGE for repair and maintenance work.

BOGE is not liable for any damage resulting from the use of other spare parts or operating materials.



Attention!

If the nozzle with dirt catch is soiled the oil consumption may increase significantly!

5.3 Regular maintenance work

Draining off the condensate from the compressed air receiver

Draining:

If no automatic condensate draining is fitted, then drain off the condensate at least once a week.



Attention!

The compressor is lubricated with oil. The condensate contains oil and may not be drained off into the public sewage system!

Pay attention to the pertaining rules and regulations of your local authorities!

- Switch off the compressor using the OFF button.



Caution: Risk of injury!

Press Emergency Stop button, open mains disconnection device and secure against unintentional switch on by means of a padlock.

- Depressurize receiver.
- Place a suitable basin underneath the condensate drain of the receiver.
- Open the ball valve and drain off the condensate.
- Close the ball valve again.
- Dispose the condensate properly.



Fig. 5.2: Draining off the condensate manually

Draining off the condensate from the compressed air receiver with automatic condensate separator

The fully automatic, electronically controlled condensate separator is equipped with a wear free sensor which monitors the condensate level in the integrated collecting basin. As soon as the collecting basin is full, a solenoid valve opens and the condensate is drained off.



Note!

Unlike the Konsatronik the fully automatic condensate separator operates without causing any pressure losses. In the event of a malfunction a red LED lights up and a potential-free contact is switched. Regularly check the function using the additional test switch on the device.

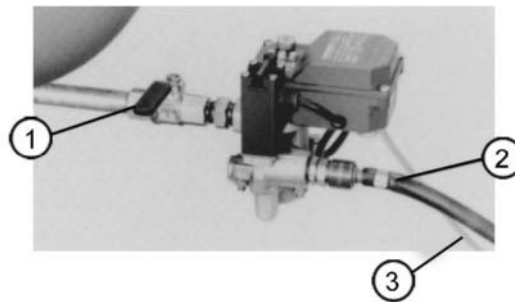

Fig. 5.3: Fully automatic, electronically controlled condensate separator

- 1 Condensate shut-off valve on receiver
- 2 Condensate outlet (to oil-water separator)
- 3 Electr. power supply

Clean or change suction filter

Cleaning:

- 1x monthly, however, at least every 500 operating hours.
- Correspondingly earlier if the air taken in is heavily soiled.

Change:

- In the event of damage.
- After the second cleaning.
- Switch off the compressor with the OFF button.



Caution: Risk of injury!

Press Emergency Stop button, open mains disconnection device and secure against unintentional switch on by means of a padlock.

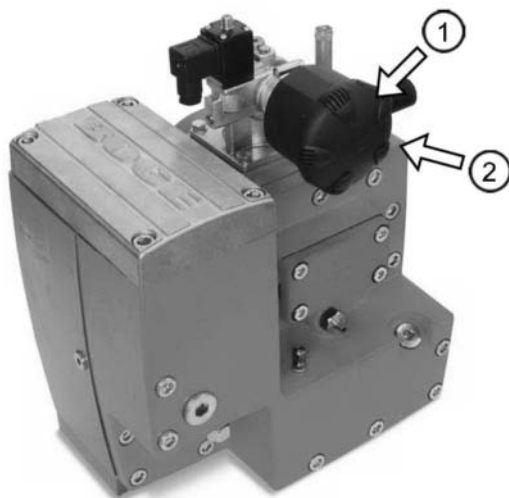
**Removing the filter cartridge**

Remove lid (1) of the filter housing.

Remove filter cartridge (2).

Fig. 5.4: Changing the suction filter

Cleaning the filter cartridge**Attention!**

Do not clean filter cartridges in liquids.

Do not use any hard objects when cleaning to avoid damaging the filter paper.

Refit a new filter cartridge in the event of damage or when it has been cleaned twice.

- Hit on the filter cartridge using the palm of your hand to knock out coarse dust.
- Blow out fine dust **from the inside to the outside** using dry compressed air (maximum pressure 5 bar).
- Clean the sealing surface of the filter cartridge.

Fitting a filter cartridge

- Insert filter cartridge into the filter housing.
- Attach lid of the filter housing.

Drive motors with permanent lubrication

As a rule, the bearings of the drive motors are provided with a maintenance free **permanent lubrication**.

Under normal operating conditions (coolant temperature max. 40°C, continuous operation) the bearings are maintenance free for the service life.

For motor maintenance see operating instructions of the compressor control.

The service life decreases or increases as thermal stress increases or decreases (due to increased or reduced coolant temperature).

**Attention!**

Have BOGE service dismantle the bearings and install new bearings once the specified service life has expired!

**Checking the oil level,
topping up oil****Check:**

- Prior to commissioning/start-up of the compressor.
- Then every 1.000 operating hours, however at least once a year.

Topping up:

- When the oil level has dropped below the "min." mark (see sketch).

**Attention!**

Always use the same oil type when topping up. Never mix different oil types and brands.

- Switch off the compressor using the OFF button.

**Caution: Risk of injury!**

Press Emergency Stop button, open mains disconnection device and secure against unintentional switch on by means of a padlock.

- Close ball valve at the compressed air outlet.
- Vent the compressor (as described in the beginning of the chapter).
- Wait approx. 3 minutes to permit the oil to settle.

**Caution: Risk of injury!**

Danger of burning due to hot oil!

Always wear safety gloves!

- Remove plug (1) of oil filling socket (2) (see figure below).
- Check oil level.
The oil level must not drop below the "min." mark (see sketch).
- If necessary, top up with oil to the lower edge of the thread ("max." mark) on the oil filling socket.
- Screw plug , back in.
- Open ball valve at the compressed air outlet.

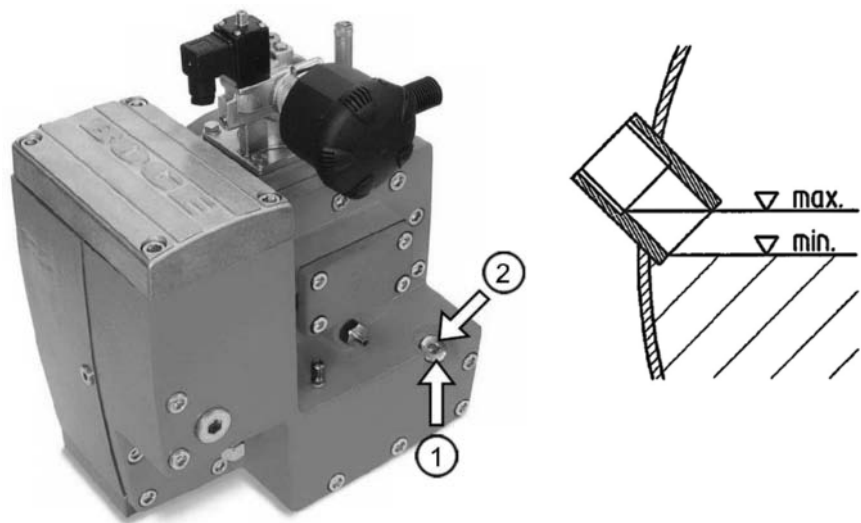

Fig. 5.5: Checking the oil level, topping up with oil

Changing the oil filter

Change:

- After the first 500 operating hours.
- After 3.000 operating hours, however, no later than after one year.
- With each oil change!

- Switch off the compressor using the OFF button.



Caution: Risk of injury!

Press Emergency Stop button, open mains disconnection device and secure against unintentional switch on by means of a padlock.

- Close ball valve at the compressed air outlet.
- Vent the compressor (procedure as described above).
- Wait approx. 3 minutes to permit the oil to settle.



Caution: Risk of injury!

Do not touch hot surfaces!

- Slacken screws on service cover (3) and remove cover.
- Take out oil filter cartridge (4) and remove from support body (5).
- Slide support body into the new oil filter cartridge.

**Attention!**

Over-current / Non-return valve(6) must be fitted facing up.

- Fit oil filter cartridge (4) with support body (5).
- Check o-rings on service cover for damage and replace if necessary.
- Fit service cover (3) and tighten screws.
- Open ball valve at the compressed air outlet.
- Switch on compressor and run till it reaches operating temperature.
- Check tightness of service cover and re-tighten screws.

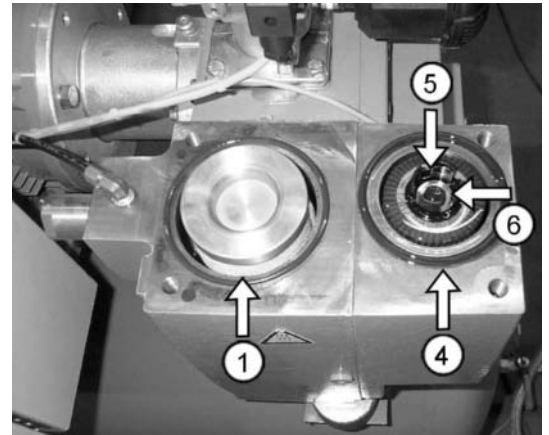
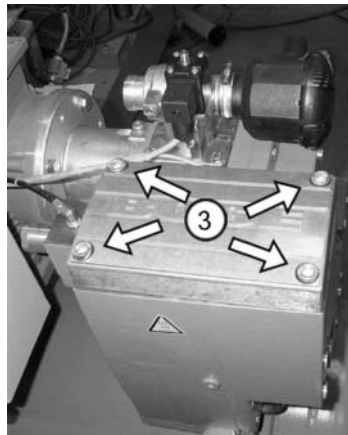

Fig. 5.6: Changing the oil filter / Changing the oil separators

Changing the oil separator

Change:

- When warning message "8" appears on the control system display (RATIO only).
- After 3.000 operating hours, however, no later than after one year.

**Caution: Risk of injury!**

If the prescribed maintenance intervals are not observed, the oil separators might become blocked. In this case, the differential pressure will increase until the safety valve blows.

- Switch off the compressor using the OFF button.

**Caution: Risk of injury!**

Press Emergency Stop button, open mains disconnection device and secure against unintentional switch on by means of a padlock.

- Do not touch hot surfaces!

- Slacken screws on service cover (3) and remove cover.
- Pull oil disperser cartridge (1) up out of the o-ring seal.
- Check seat of o-ring.
- Lightly oil bottom of new cartridge in and press into o-ring seal.
- Check o-rings on service cover for damage and replace if necessary.
- Fit service cover (3) and tighten screws.
- Open ball tap at compressed air exit.
- Switch on compressor and run till it reaches operating temperature.
- Check tightness of service cover and re-tighten screws.

Oil change

Change:

- After 9.000 operating hours, however, at the latest after two years.
- For other types of oil the appropriate oil change intervals must be complied with.



Note!

The service life of the oil, the oil filter and oil separators is reduced under the following conditions:

- When the compressor is operated at extreme ambient temperatures.
- When the intake air is extremely soiled.

Building up a pressure cushion

The combined compressed air / oil receiver is located at the lowest point of the system. Therefore, a light pressure cushion (approx. 1.5 bar system pressure) must be applied to drain the oil. This pressure cushion forces the oil through the drain hose into a suitable collecting basin.

- Switch off the compressor using the OFF button.



Caution: Risk of injury!

Press Emergency Stop button, open mains disconnection device and secure against unintentional switch on by means of a padlock.

Draining old oil

- Switch off compressor.
- Open ball valve at the compressed air outlet.
- Switch off compressor. After approx 2 sec screw cap nut (5) on the bleed aperture of the magnetic valve (the nut is located in the storage compartment of the switch cabinet).



Caution: Risk of injury!

Danger of burning due to hot oil!
Always wear safety gloves!

- Remove blind plu (1) at oil drain (3) with the tap closed.
- Fit oil drainage hose (2) (the hose is located on the machine).
- Place the oil drain hose into a suitable container.
- Slowly open the stop valve. The pressure cushion forces the oil into the container.
- Once the compressed air/oil receiver has been completely drained, close the stop valve.
- Remove oil drainage hose and replace blind plug with new copper seal.
- **Remove the cap nut from the solenoid valve.**
- Change oil filter (procedure as described above).
- Change oil separators (procedure as described above).

Filling with new oil:

- Fill up to the edge of the thread of the filling socket (max.) (procedure as described above).

**Attention!**

After each oil change you have to fill a small quantity of oil into the suction controller before starting the compressor.

For oil quantity and procedure see chapter "Installation", chapter "Commissioning following extended stoppages".

**Attention!**

Always fill with the same oil type as previously used. Never mix different oil types and brands.

The oil circuit must be flushed prior to changing the oil type.

- Conduct trial run.

**Caution: Risk of injury!**

Press Emergency Stop button, open mains disconnection device and secure against unintentional switch on by means of a padlock.

- Check the oil filters and oil separators for leaks and tighten by hand, if necessary (procedure as described above).
- Check oil level (procedure as described above).
Top up oil losses, if any.

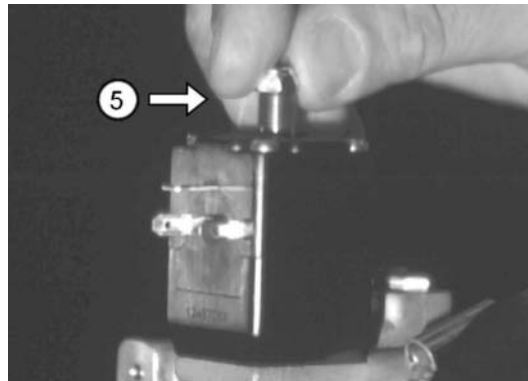

Fig. 5.7: Solenoid valve on the suction controller with the cap nut screwed on

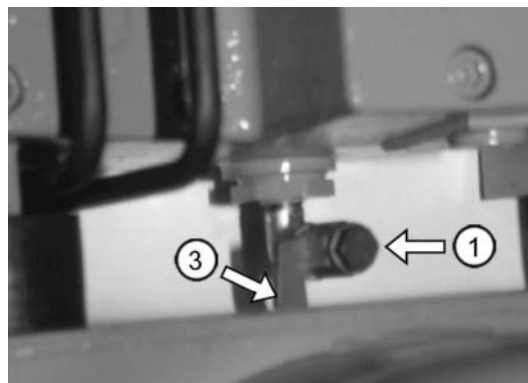

Fig. 5.8: Oil drain from oil compressed air receiver

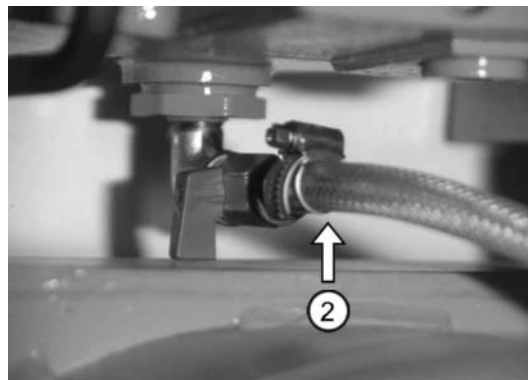

Fig. 5.9: Oil drain with fitted oil drainage hose

Flushing the oil circuit

Flushing the oil circuit with clean oil becomes necessary:

- When the oil is excessively soiled.
- Prior to changing the oil type.



Attention!

Detailed information as to the flushing with BOGE oils you can obtain from the following service number:

Telephone: +49 5206 601-140

Cleaning the compressed air/oil cooling unit

Cleaning:

- After 1.500 operating hours, however, at the latest after one year.



Note!

The service life of the compressed air/oil cooling unit depends on the degree of soiling (dust, oil vapour) of the suctioned cooling air. Extreme external soiling of the cooling unit leads to an increased temperature in the oil circuit.

- Switch off the compressor using the OFF button.



Caution: Risk of injury!

Press Emergency Stop button, open mains disconnection device and secure against unintentional switch on by means of a padlock.



Attention!

Do not use any sharp objects for cleaning!

These could damage the cooling unit!

- Blow down the dirt with compressed air in the opposite direction to the normal cooling air flow. Vacuum out the dirt using an industrial vacuum cleaner.

If the cooling unit is excessively soiled (cleaning is no longer possible with compressed air), have it disassembled and cleaned by BOGE service.

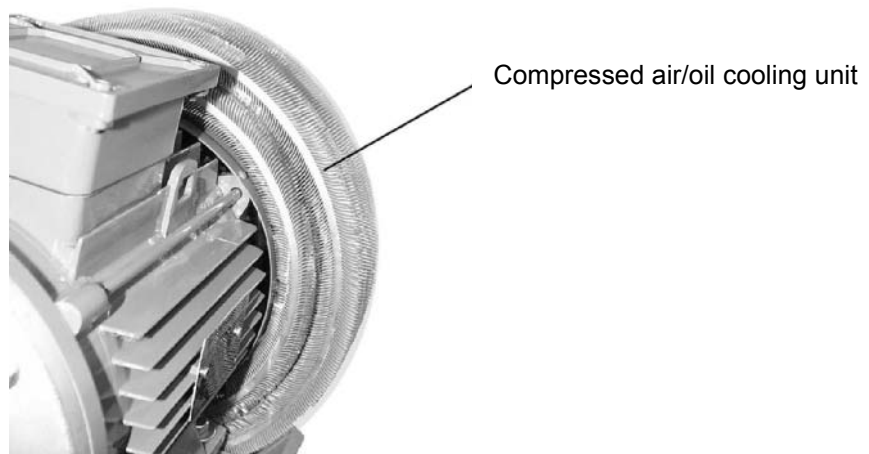

Fig. 5.10: Cleaning the compressed air/oil cooling unit

Checking the safety valve**Check:**

- After approx. 3.000 operating hours, however, at least once a year. Check safety valve by opening the screw plug (1).

**Caution: Risk of injury!**

Danger of burning due to hot oil!

Take extreme care when checking the safety valve with the compressor running taking all safety measures into consideration.

Always wear safety gloves!

A hot air-oil mixture escapes when opening!

- Open the threaded plug (1) anticlockwise. The compressed air escapes.
- Tighten the threaded plug by turning clockwise.

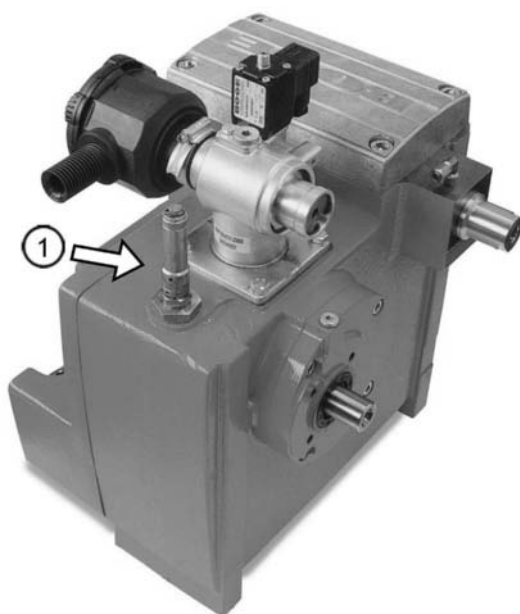

Fig. 5.11: Check safety valve

5.4 Spare parts and optional equipment

List of spare and wearing parts (for maintenance)

Designation
Compressor oil Syprem 8000 S
Maintenance kit consisting of: oil filter, oil separator, suction filter cartridge, gaskets, nozzle with dirt catch
Wearing part kits for: oil regulator, minimum pressure valve, solenoid valve
Intake regulator incl. solenoid valve

List of available optional equipment

Designation
Optional equipment for compressed air treatment
Oil/water separator
Automatic condensate draining unit Bekomat



Attention!

When ordering, please specify the data on the type plate:

- Type
- Year of manufacture
- Machine number

6.1 Guidelines and standards complied with

The compressor conforms to the following guidelines and standards:

Guidelines and directives

- EC Machine Directive 2006/42/EC
- Pressure Equipment Directive 97/23/EC
- EMC Guideline 2004/108/EC
- Low Voltage Directive 2006/95/EC

Applied harmonized standards

- DIN EN 1012-1:1996
- DIN EN ISO 13857:2008
- DIN EN ISO 12100-1:2004
- DIN EN ISO 12100-2:2004
- DIN EN 60204-1 / VDE 0113-1:2007
- DIN EN 61000-6-2 / VDE 0839-6-2:2006
- DIN EN 61000-6-4 / VDE 0839-6-4:2007

6.2 Flow chart

On the following pages you will find the individual flow charts for the different machine types and components.

**Air cooled version,
standard**

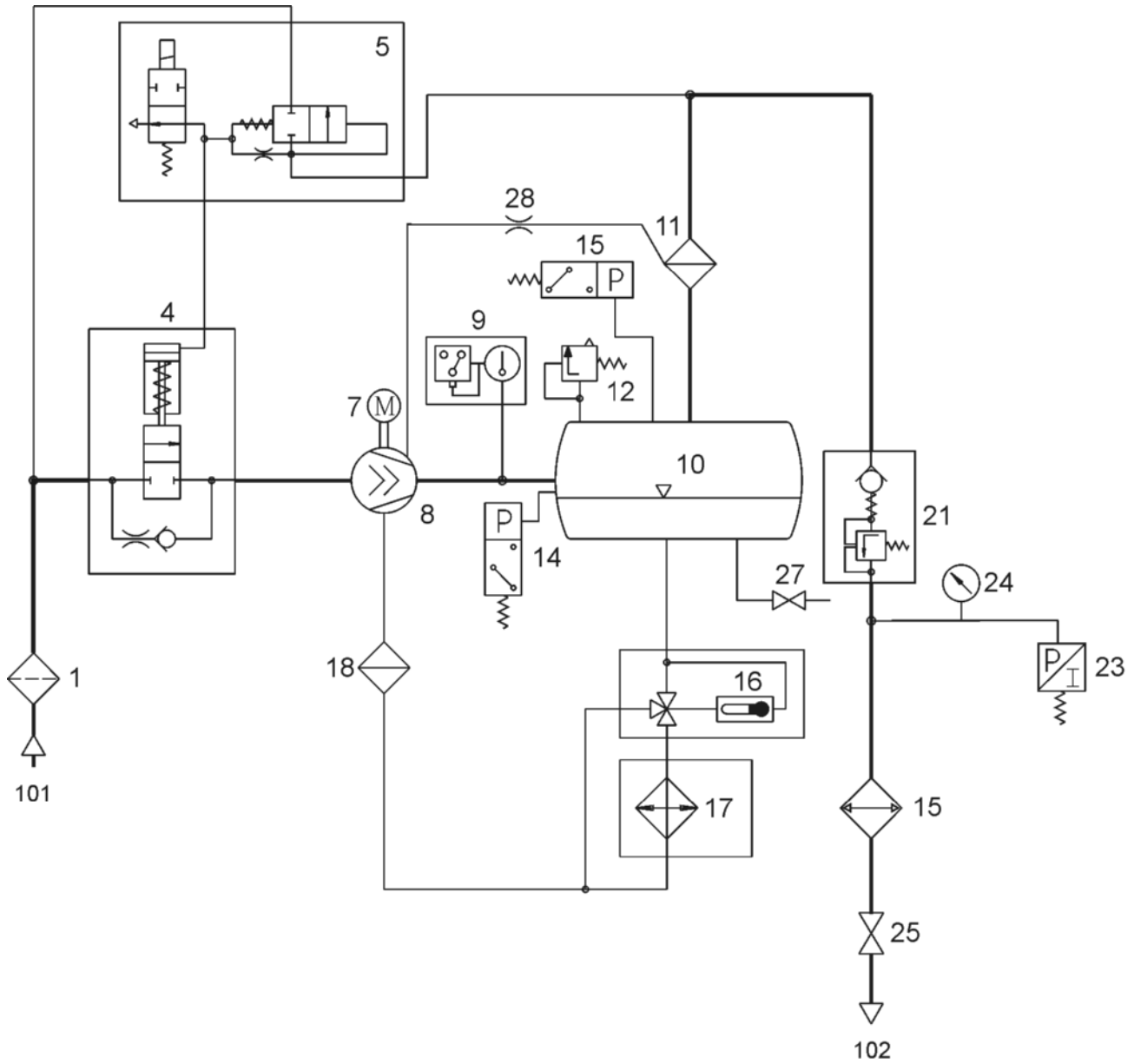

- 101 Intake air INLET
- 102 Compressed air OUTLET

- 1 Suction filter
- 4 Suction controller
- 5 Ventilation and regulation control valve
- 7 Drive motor
- 8 Compressor air end
- 9 Final compression temperature display and switch
- 10 Combined compressed air/oil receiver
- 11 Oil separator
- 12 Safety valve
- 15 Compressed air after-cooler
Optionally for receiver systems without refrigeration compressed airdryer
- 16 Thermostatic oil control valve
- 17 Oil cooler
- 18 Oil filter
- 21 Minimum pressure check valve
- 23 Network pressure transmitter
- 24 Pressure gauge reading in display
- 25 Stop valve, compressed air outlet
- 27 Stop valve, oil drainage
- 28 Throttle with filter

