



**WATER SOFTENER
WITH 12 DAY SERIES
TIMER CONTROL**

**INSTALLATION & OPERATING
INSTRUCTIONS**

Model : AS0715-940
Serial No :

Manufacturer and Supplier of



FILTRATION & WATER TREATMENT PRODUCTS
for commercial, industrial and residential application



Telephone: (07) 3219 2233
Email: sales@ibewater.com.au

Facsimile: (07) 3219 2266
Website: www.ibewater.com.au

HARDNESS TEST

1. Water to be tested should be taken from a tap after the water softener
2. Measure 10ml of water into plastic bottle supplied (approximately 1/3 full)
3. Add one Yes/No tablet to sample water, replace cap and shake until tablet has completely dissolved.
(NOTE: do not handle Yes/No tablet with fingers)
4. The final colour to be obtained for soft water is green. (Note: The shade of green may vary.) If the colour turns red, the water is above 20 mg/l hardness, therefore another regeneration is recommended.
5. Rinse plastic bottle after each test has been completed.
6. When used as above, the tablets change the colour from green to red at a hardness of approximately 20ppm based on a sample volume of 10mls.

Other hardness test kits are available for more accurate testing eg.

Hardness Tablets

Directions: Take a 50ml sample of water in a screw capped bottle. Add one (1) tablet to sample, shake or crush to disintegrate. Repeat until last trace of reddish tinge disappears. The final colour is usually blue but with some water a greyish coloured end point is obtained.

Using 50ml sample -
Hardness ppm = (number of tablets x 40) - 20

LR (BW) Tablets

Directions: Take a 100ml sample of water in a screw capped bottle. Add one (1) tablet to sample, shake or crush to disintegrate. Repeat until last trace of reddish tinge disappears. The final colour is usually blue but with some water a greyish coloured end point is obtained.

Using 100ml sample -
Hardness ppm = (number tablets x 2) – 1

Contact IBC Water if further details are required.

WATER SOFTENER CALCULATIONS

MODEL AS0715-940

To ascertain **DAYS** between regeneration periods the following data or estimations are required.

(Let **N** be the number of days to be calculated)

- .1. $\bar{\theta}$ Water Hardness in mg/l call $\bar{\theta}$ H
- .2. $\bar{\theta}$ Water Softener Hardness Removal Capacity from Table 1 in grams call $\bar{\theta}$ C
- .3. $\bar{\theta}$ Daily Water Usage in litres call $\bar{\theta}$ D

For household situations allow 250 litres per person per day.

CALCULATION

$$N = \frac{1000 \times C}{D \times H}$$

Select nearest lower whole number

If necessary consult your dealer or IBC Water Treatment for advice on setting up the softener.

EXAMPLE

Household use for 2 people on 220 mg/l hard water using Model AS0715 at 1050 grams capacity.

$$\begin{aligned} N &= \frac{1000 \times 1050}{500 \times 220} \\ &= 9.5 \text{ days} \\ &= 9 \text{ days} \end{aligned}$$

Note: Maximum number of days that can be selected is twelve (12).

WATER SOFTENER PERFORMANCE DATA SHEET

Automatic Model No.	Capacity & Salt Dosage		Recommended Maximum Service Flow Rate	Pipe Size		Resin Volume	Approx. Shipping Weight (kg)	Space Required
	Minimum	Maximum		Inlet Outlet	Drain			
	gram/kg	gram/kg	Flow LPM	mm	mm	Litres	Per Kg	metres
AS0715-940	525/1	1050/3.6	15	25	12	15	27	0.70 0.50 1.2

CABINET/BRINE CHAMBER: POLY MOULDED

Operating Pressure: 140 - 690 kPa

Temperature: 5° x 50°C

Electrical: 240V 50Hz 3 watts maximum

WARNING

A pressure reduction valve should be installed in areas of high water pressure (above 690kPa)

A water hammer arrestor should be installed if water hammer prevails.

Caution: Do not use where water is microbiologically unsafe or with water of unknown quality.

FAILURE TO OBSERVE WARNINGS WILL VOID WARRANTY

INSTALLATION OF

IBC CABINET WATER SOFTENER UNIT

FITTED WITH MODEL 255 VALVE/940 CONTROL

Check the equipment upon arrival for damage or shortages and report same to our Office or Agent before starting.

Position the Softener Cabinet on a firm foundation, preferably concrete, with sufficient space for operation and maintenance.

- STEP 1 Connect inlet, outlet pipes and drain line to control valve as per Instruction Booklet (page 5, figure 3).
Note: The softener is supplied with the Autotrol Series 156 Bypass Valve as standard.
- STEP 2 Remove lid from brine tank. Then connect brine overflow drain line to waste trap.
- STEP 3 Refer to Instruction Booklet for start up procedure (page 6 “Placing conditioner into Service”).
- STEP 4 Load recommended quantity of water softener salt into brine tank and replace lid (refer to Table 3 “Brine Tank Salt Loading”).

Table 3

MODEL	RESIN LITRES	BRINE TANK - SALT LOADING KG
AS0715-940	15	50

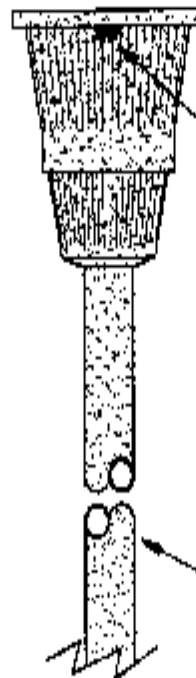
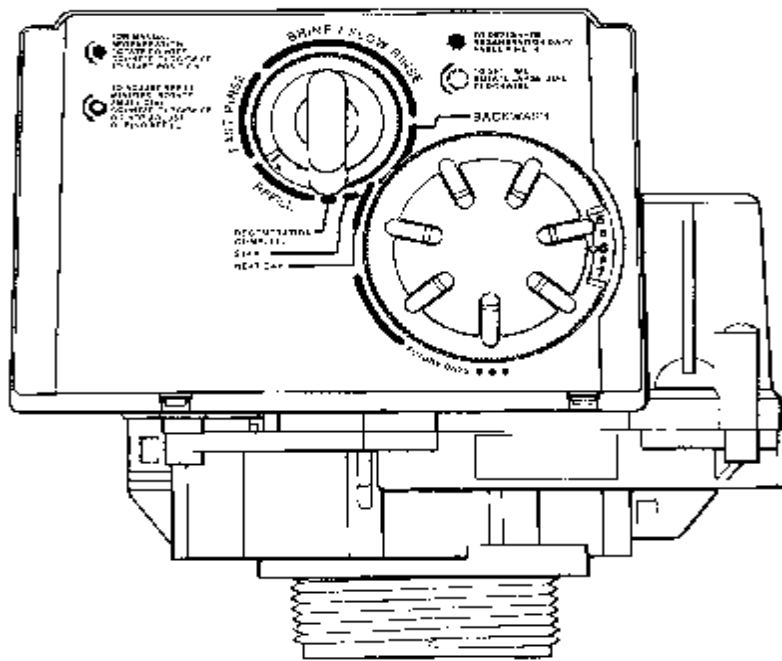

ASSEMBLE TOP STRAINER
TO VALVE BODY
PUSH AND TWIST

INTERNAL RISER PIPE

NOTE:

ON A NUMBER OF SOFTENER MODELS AND FILTERS IT IS NECESSARY TO PACKAGE THE VALVE WITH THE TOP STRAINER SUPPLIED LOOSE.

IT IS IMPORTANT THAT THIS STRAINER IS ASSEMBLED TO THE VALVE DURING INSTALLATION.

THE LENGTH OF THE INTERNAL RISER PIPE IS FACTORY ADJUSTED FOR THE TANK SIZE PROVIDED.

DO NOT SHORTEN THIS PIPE UNDER ANY CIRCUMSTANCES

940I Low Voltage Timer Control

The softener Control fitted is powered by a 240 to 12 Volt Transformer. The Transformer plugs into a 10amp 240volt GPO and the transformer lead plugs into a socket located on the back of the timer at the left-hand side. The Transformer is only suitable for indoor mounting.

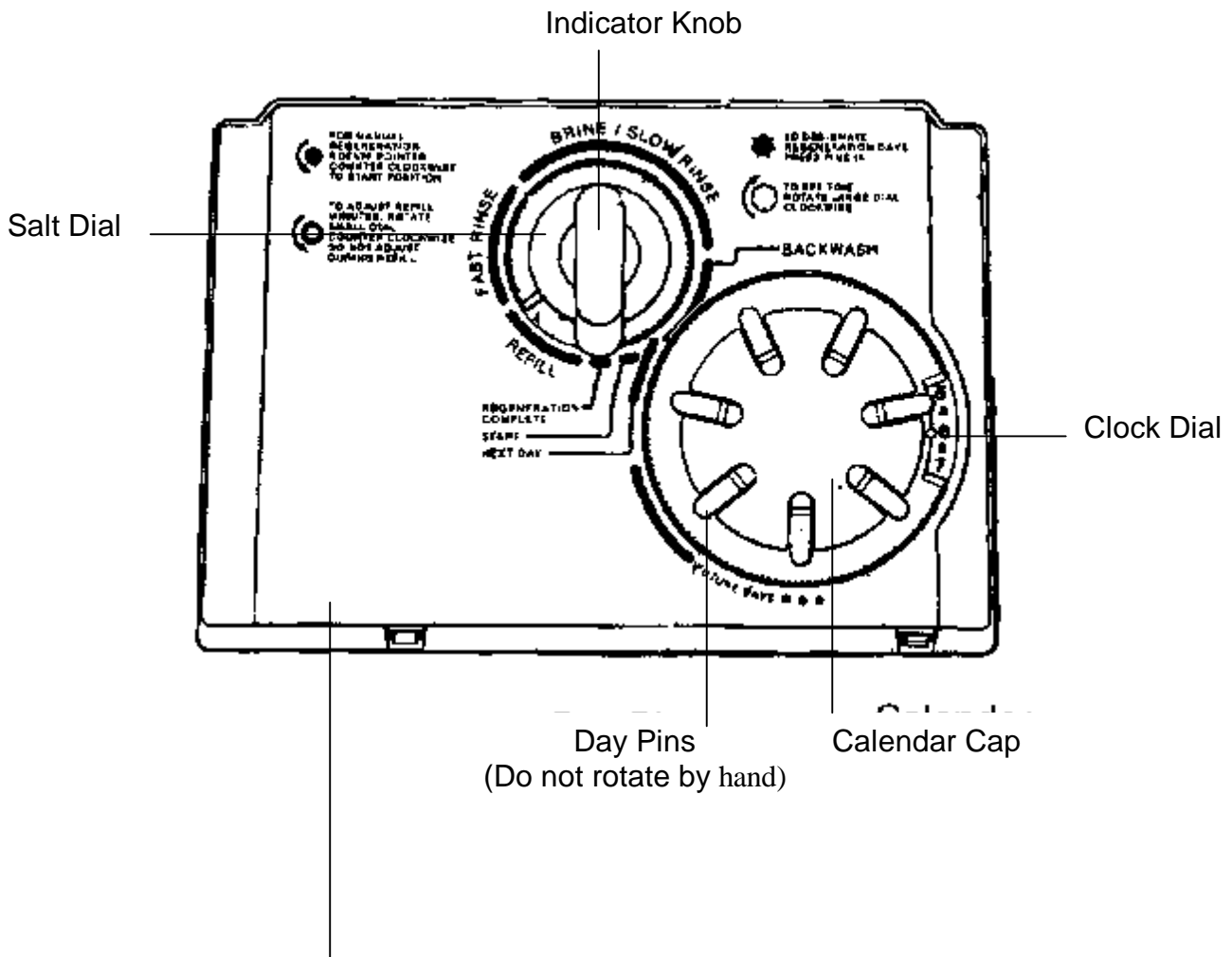

Low Voltage Transformer
 Only use the included transformer for powering the Timer. Connect the plug of the transformer cable to the mating socket at the rear of the Timer housing on the left-hand side.

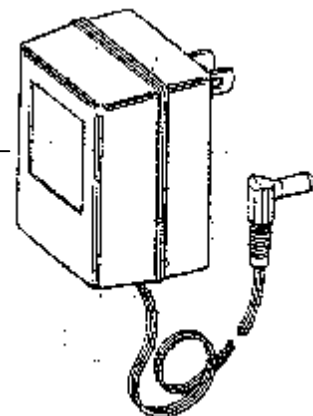

When ordering spare parts: - Advise that the Timer is the low voltage model

Series 255 Valve / 940 Control

Water Conditioning Control System
Installation, Operating and Maintenance Manual

Table of Contents

	Page
Introduction	10
Superior Design	
Superior Operation	
Installation	10
Location Selection	
Water Line Connection	
Drain Line Connection	
Brine Line Connection	
Brine Tank Overflow Line Connection	
Electrical Connection	
Placing Conditioner into Operation	13
Adjustment of Timer	14
Special Features of Timer	
Adjustment of Brine Control	14
How to Set the Salt Dial	
Service	15
Removing the Timer Assembly	
Removing the Valve Assembly	
Preventative Maintenance	17
Injector Screen and Injector	
Specifications	18
Pressure Graphs	19
Control Valving identification	20
Valve Disc Operation	20
Flow Diagrams	21
Replacement Parts	22
Trouble Shooting	26
Disinfection of Water Conditioners	27

Introduction

Thank you for purchasing a water conditioner system featuring the Series 255 with a model 940 Control.

The Model 940 Control provides dependable time clock based operation. The Series 255 valve combines simplicity with reinforced NORYL * construction to provide an uncommonly reliable appliance. The inherent quality of the system means a long life of efficient, trouble-free soft water. If maintenance becomes necessary, the Series 255/940 Control offers a unique separation capability illustrated in the Service section of this manual.

Superior design

- **Single synchronous electric motor** provides all the power for the clock and the operation of the control.
- **Electrical wiring is factory assembled.** System cannot be connected incorrectly.
- **Program clock 940 (timer) and 960 Demand system are interchangeable.** Both units provide guest regeneration capability.
- **System may be indexed manually with or without power** to any one of its service or regeneration positions. Legend on timer faceplate indicates control valve position.
- **No moving parts in water stream** means no close tolerance parts subject to fouling. Thus, the system is especially effective on iron-bearing water.
- **No dynamic seals** that could cause leakage through wear or fatigue.
- **Control accepts NORYL* or brass manifold or modular bypass valve without modification,** offering complete versatility and easy plumbing for any installation.
- **Brining control valve built into system** eliminates need for any brine valve.
- **Drain flow control** is built into the valve to control backwash and fast rinse flow rates.
- NORYL is a trademark of GE Plastics.

Superior Operation

- **Direct acting system** functions independently of water pressure. No pistons or diaphragms that require a minimum water pressure to operate.
- **Five-cycle operation** provides for down flow service, up flow backwash, down flow brining, down flow slow and fast rinse. A sixth position is included for timed refill of the brine tank.
- **Valve discs are held closed by water pressure** and therefore, are leak tight. The sealing forces are increased as the water pressure is increased. Valve seats are in a vertical position, which is design position least vulnerable to plugging.
- **System operation cannot get out of phase or sequence.** The control always returns to a fixed service position of regeneration regardless of where in the regeneration cycle it was started.
- **Bypass (unconditioned) water is automatically available** during regeneration.

Installation

All plumbing and electrical connections must conform to local codes. Inspect the unit carefully for carrier shortage or shipping damage.

Location Selection

- Locate unit as close to a drain as possible
- If supplementary water treating equipment is required, make sure that adequate additional space is available. Locate the brine tank in an accessible place so that salt can easily be added.
- Do not install any unit closer than 10ft (3m) of piping between the outlet of the water conditioner and the inlet of the water heater. Water heaters can transmit heat back down the cold water pipe into the control valve. Hot water can severely damage the controller.

A 10ft (3m) total pipe run (including bends, elbows etc) is a reasonable distance to prevent hot water damage. A positive way to prevent hot water from flowing from a heat source to the conditioner is to install a check valve in the soft water piping from the conditioner. If a check valve is installed, make sure that the water-heating unit is equipped with a properly rated temperature and pressure safety relief valve. Always conform to local codes.

- Do not locate the unit in an area where the temp ever falls below 34°F (1°C) or over 120°F (49°C).
- Do not install the unit near acid or acid fumes.
- Do not expose the unit to petroleum products.

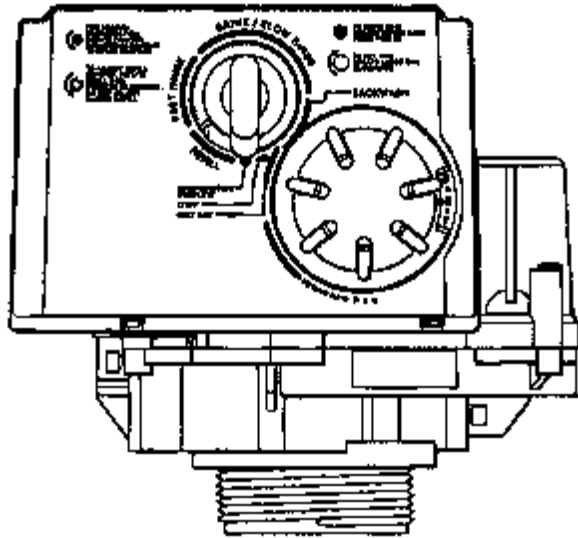
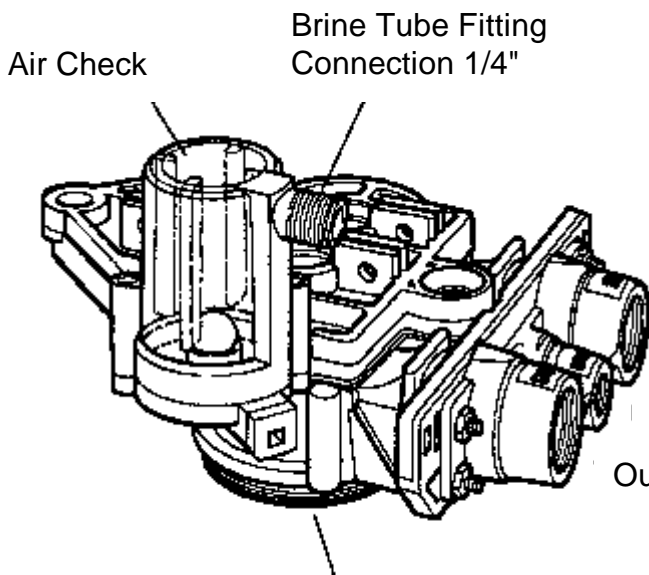
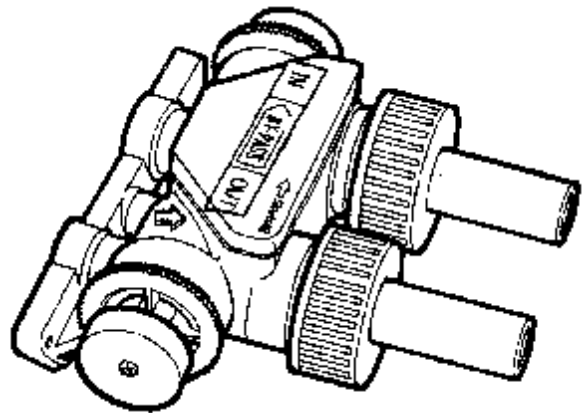

Figure 1 - Control

Bypass Valve (optional)



Inlet Connection 3/4" or 1" NPT or BSPT
 Drain Connection 3/8" or 1/2" NPT or BSPT
 Outlet Connection 3/4" or 1" NPT or

Tank Tread 2-1/2" - 8 male NPSM

Figure 2 - Tank Adaptor

Water Line Connection

A bypass valve system must be installed to provide for occasions when the water conditioner must be bypassed for hard water or for servicing. The most common bypass systems are the Autotrol Series 156 Bypass Valve, Figure 3, and plumbed-in globe valves, Figure 4. Though both are similar in function, the Autotrol Bypass offers simplicity and ease of operation.

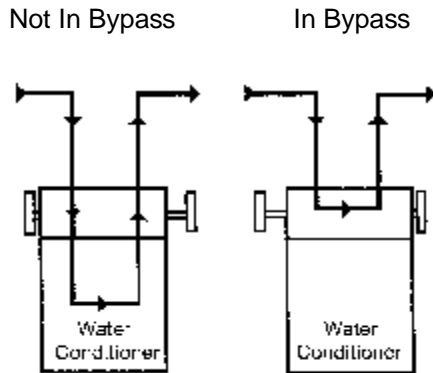

Figure 3 - Autotrol Series 156 Bypass Valve

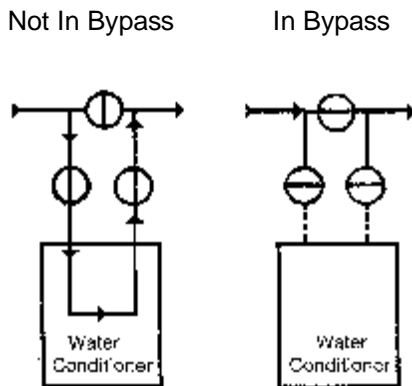

Figure 4 - Typical Globe Valve Bypass

Drain Line Connection

The drain line discharges water and brine during the regeneration cycles. Typically, the line drains into a floor drain or laundry tube. Plumb the drain line according to local codes, leaving a one or two inch air gap between the end of the drain line and the opening, Figure 5.

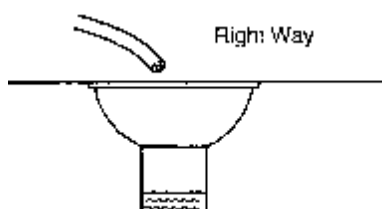

Figure 5 - Air Gap Installation Caution

Never connect the drain line into a drain, sewer line or trap. Always allow an air gap between the drain line and the wastewater to prevent the possibility of sewage being back-siphoned into the conditioner.

The ideal location for the unit is above and not more than 20ft (6.1m) from the drain. For such installations, using the appropriate adaptor fitting (not supplied), connect 1/2 in (1.3cm) plastic tubing to the drain line connection located at the rear of the control.

If the unit is located more than 20ft (6.1m) from the drain, use 3/4in (1.9cm) tubing for runs up to 40ft (12.2m). You may elevate the line up to 6ft (1.8m) providing the run does not exceed 15ft (4.6m) and the water pressure at the conditioner is not less than 40psi (280kPa). You may elevate an additional 2ft (61cm) for each additional 10psi (70kPa) of water pressure. When the drain line is elevated and empties into a drain which is below the level of the control valve, form a 7 inch (17cm) loop at the drain end of the line so that the bottom of the loop is level with the drain line connection. This provides an adequate siphon trap. If the drain empties into an overhead sewer line, a sink-type trap must be used.

Note: The above instructions reflect standard commercial practices. Local codes may require different installation procedures.

Brine Line Connection

Install the brine tube and connect to the fitting connection located on the air check on the tank adaptor module, see Figure 2.

Note: Make sure that all fittings and connections are tight so that premature checking does not take place. Premature checking occurs when the ball in the air check falls to the bottom before all brine is drawn out of the brine tank. Refer to the **Troubleshooting** section in this manual for additional information.

Brine Tank Overflow Line Connection

In the event of a malfunction, the tank overflow connection directs overflow to the drain instead of spilling on the floor where it could cause water damage. Complete the following steps to connect the overflow fitting to the brine tank:

1. Locate the fitting hole on the side of the brine tank.

2. Insert the overflow fitting (not supplied) into the tank and tighten with the plastic thumbnut and gasket as illustrated in Figure 6.
3. Attache a length of 1/2in (1.3cm) tubing (not supplied) to the fitting and run to the drain.

Note: Don not elevate the overflow line higher than 3in (7.6cm) below the bottom of the overflow fitting. Do not tie into the drain line of the control unit. The overflow line must be a direct, separate line from the overflow fitting to the drain, sewer or tube. Allow an air gap as in the drain line connection, Figure 5.

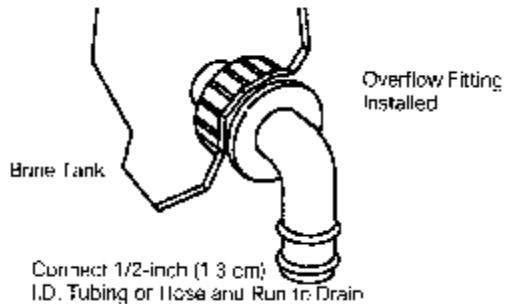

Figure 6 - Overflow Line Connection

Electrical Connection

Remove the twist tie from the power cord and extend the cord to its full length. Make the power source matches the electrical rating of the control. Be sure the outlet you select is not controlled by a wall switch.

Placing Conditioner into Operation

After the water conditioning system is physically installed, we recommend that the conditioner be disinfected before it is used to treat potable water. Refer to the **Disinfection of Water Conditioners** section in this manual. Complete the following steps to place the conditioner into service.

1. Grasp the indicator knob on the timer (Figure 8) and rotate it **counterclockwise** about 45° to the back-wash position. You may find it helpful to remove the rear cover (Figure 10) and rotate the camshaft counterclockwise at the same time.
2. Fill the mineral tank with water by turning the water supply off and placing the bypass valve(s) into the "not in bypass" position. Open the water supply valve very slowly to approximately the 1/4 open position.

Caution

If the water supply valve is opened too rapidly or too far, resin may be lost. In the BACKWASH position, you should hear air escaping slowly from the drain line.

3. When all the air is purged from the tank (water begins to flow steadily from the drain), slowly open the main supply valve all the way. Allow the water to run into the drain until the water appears clear. Turn off the water supply and wait for about five minutes to allow all trapped air to escape from the tank.
4. Add water to the brine tank (initial fill). With a bucket or hose, add approximately 4 gallons (15 litres) of water to the brine tank.

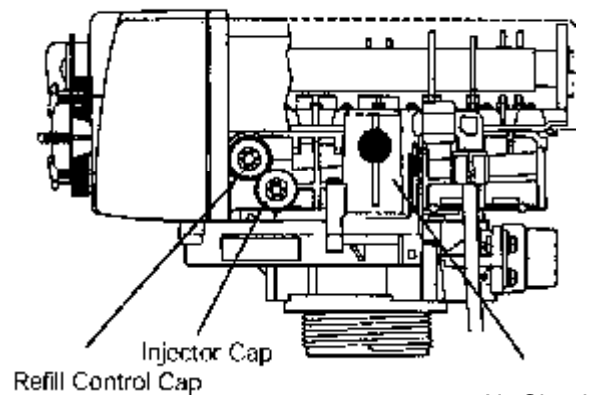

Figure 7

5. To start up the unit: make sure the water supply valve is in the full open position. Carefully rotate the indicator knob, Figure 8, **counterclockwise** until the indicator points directly to the centre of the **REFILL** position and hold there until the air check (Figure 7), fills with water and water flows through the brine line into the brine tank. Do not run the water into the brine tank for more than one or two minutes.

Rotate the indicator knob **counterclockwise** until the indicator points to the centre of the **BRINE/ SLOW RINSE** position.

Check the water is being drawn from the brine tank. The water level in the brine tank will recede very slowly. Observe the water level for at least three minutes. If the water level does not recede, if it goes up, or if air enters the air check sight glass and the ball falls and seats, refer to the **Troubleshooting** section in this manual.

Finally, rotate the indicator knob **counterclockwise** until the indicator points to **REGENERATION COMPLETE**. Run water from a nearby cold-water faucet until the water is clear and soft.

Adjustment of Timer

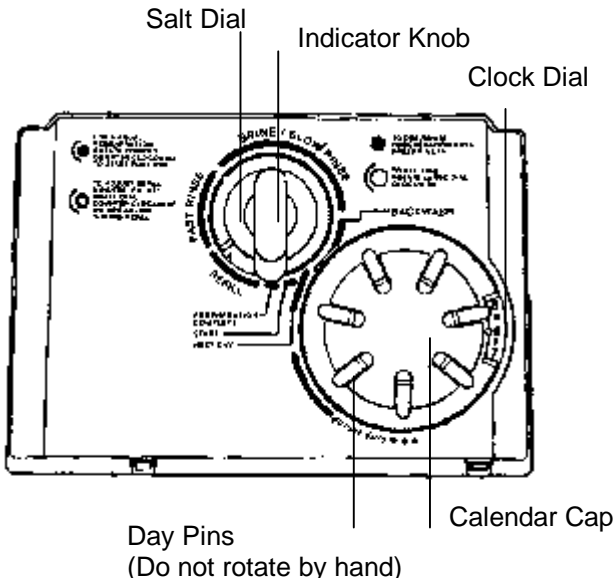

1. Set days of regeneration (Figure 8).

- Pull all day pins outward (away from control)
- Depress day pin(s) at day(s) for which regeneration is desired.

Note: The NEXT DAY day pin is noted on the timer face. Depressing this pin will insure regeneration the next day at approximately 2:00am. Since the calendar cap progresses clockwise, depressing the day pin immediately counterclockwise will insure regeneration the following day at 2:00 am. This progression is noted on the timer face as "FUTURE DAYS".

2. Set the time of day.

- Rotate Clock Dial until the pointer is directed at the current time.

Note: With the time of day properly set, the conditioner will regenerate at about 2:00 am. If you prefer to have the unit regenerate at an earlier or later time, simply set the current time-of-day accordingly. (e.g., To have the unit REGENERATE at 4:00am - 2 hours later - set the clock 2 hours later than the actual time).

Note: Do not rotate the Calendar Cap by hand; the clock dial indexes it daily. To manually index the Calendar Cap, rotate the Clock Dial clockwise one complete turn for every day to be indexed.

Special Features of Timer

Guest Cycle. When abnormally high water usage exhausts the water conditioner's capacity ahead of schedule, an extra regeneration can be achieved by turning the indicator knob **counterclockwise** to **START**, Figure 8. It will take a few minutes for regeneration to begin. The normal regeneration schedule will not be disrupted.

Manual Regeneration. Electricity is used only to run the timer and to rotate the camshaft. All other functions are operated by water pressure. Therefore, in the event of a power outage, all the various regeneration positions may be dialled manually by rotating the indicator knob **counterclockwise**.

Manual time cycle:

BACKWASH.....	14 minutes
BRINE AND SLOW RINSE.....	52 minutes
FAST RINSE.....	6 minutes
REFILL.....	Read time Off Salt Dial

Adjustment of Brine control

All models may be tuned to produce maximum to minimum conditioning capacities by adjusting the Salt Dial (Figure 9). The Salt Dial controls the amount of salt used per regeneration. When desired, the minimum setting may be used if the frequency of regeneration is increased to compensate for the lower regenerated conditioning capacity.

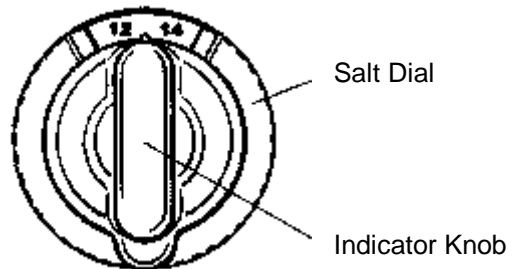

How to Set the Salt Dial

With the indicator knob in the REGENERATION COM-LETE position (Figure 8), rotate the Salt Dial counterclockwise at least one full turn to cancel out the previous setting. A light clicking will be replaced by a heavier clicking when the previous setting is cancelled. Then, rotate the Salt Dial to the proper salt setting.

The numbers on the dial are "minutes" of water flow to the brine tank. When using the .4 gpm Brine Refill Control, each minute corresponds to 1.2 pounds of salt. The size of the brine control is embossed on the refill cap. The embossed number corresponds to the gpm flow control. Example: **33** corresponds to .33

gpm flow control. One gallon of water will dissolve 3.0 pounds of salt.

To calculate the time for brine refill, it is necessary to determine the needed pounds of salt and divide that number by three (3 pounds per gallon) and also divide by the flow control gpm. The result is the time setting in minutes for brine refill. Be sure to round off times to the nearest minute

Figure 10

Reference Tab

MODEL AS0715-940 WATER SOFTENER		
HARDNESS REMOVAL CAPACITY INGRAMS	SALT USAGE IN KILOGRAMS	SALT DIAL SETTING TIME IN MINUTES
525 (MIN)	1.0	3
700	1.6	4
825	2.2	6
1050 (MAX)	3.6	9

NOTE: - THIS SOFTENER IS FITTED WITH THE 0.33 G.P.M BRINE REFILL CONTROL

Service

Removing the Timer Assembly

Complete the following steps to remove the timer assembly for servicing:

1. Unplug the power cord.
2. Remove the rear cover by pushing back on the tab provided on the cover with your thumb, Figure 10. Next, lift the cover off the valve.
3. To remove the camshaft (or reinstall it), the rib on the shaft must be pointing straight up. This occurs when the indicator knob is rotated to the refill position. Press down on the back of the camshaft to disengage it from the rear "hoop" of the top plate, Figure 11.

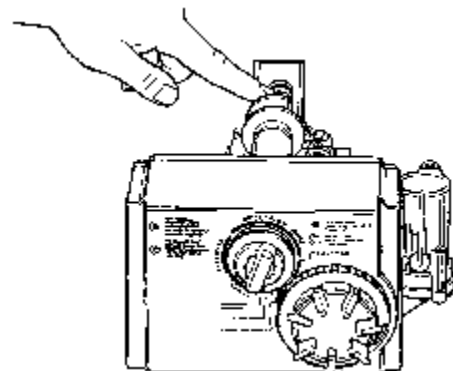
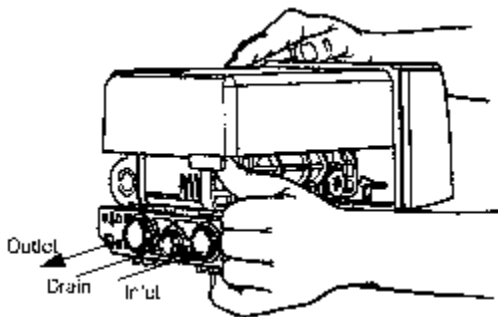

Figure 11

- Slide the camshaft back, disengage it from the timer, Figure 12.

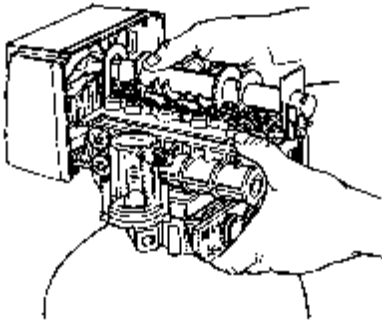

Figure 12

- Lift the timer off the valve, Figure 13.

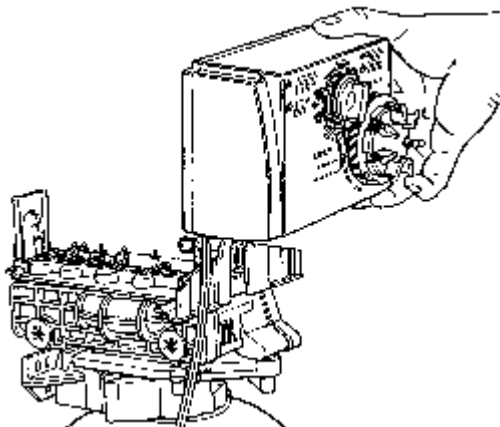

Figure 13

- To replace the timer, reverse the above Procedure.

Note: The camshaft and the timer indicator knob need to be positioned correctly before the camshaft can be installed. Rotate the camshaft such that the locating rib is pointing straight up. The timer indicator knob must be in the **REFILL** position when installing the camshaft. Slide the camshaft into the timer. It may be necessary to rock the timer slightly to key the camshaft into the timer. When the camshaft is slid into place, lift the back of the camshaft up while rotating the indicator knob to seat the camshaft in the top plate "hoop".

Removing the Valve Assembly

Complete the following steps to remove the valve assembly:

- Unplug the power cord.
- Shut off the water supply or place in bypass
- Relieve the system pressure by opening the rinse drain valve (the fifth valve back from the timer)

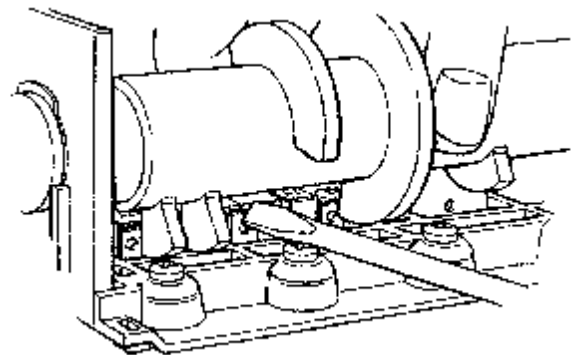

Figure 14

- Remove the locking bar screw, Figure 15.

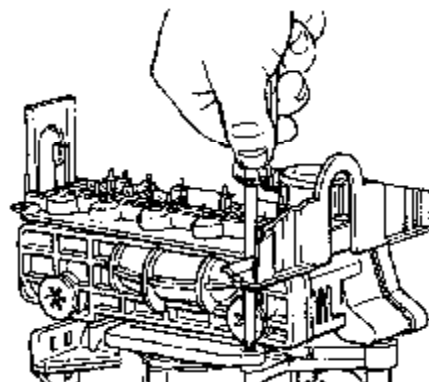

Figure 15

5. Apply downward hand pressure on the valve and remove the locking bar, Figure 16.

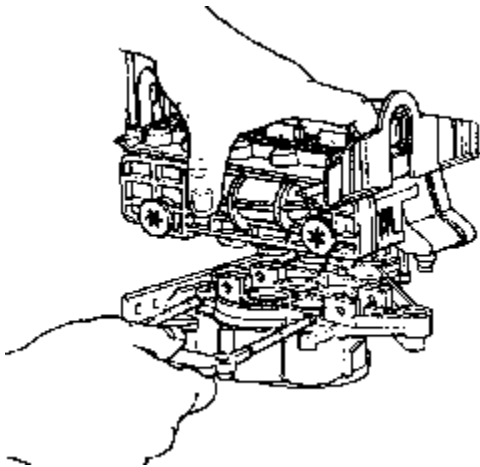

Figure 16

6. Using the rocking motion, lift the valve from the tank adaptor, Figure 16. If the o-ring seals come off with the valve put them back into the tank adaptor sockets. Lubricate the o-rings with silicone lubricant.

Note: Petroleum based lubricants will damage the Plastic valve and o-rings.

Reverse the procedure to replace the valves.

Preventative Maintenance

Injector Screen and Injector

The injector is the component which creates the vacuum necessary to draw the brine into the water conditioner. Clean the injector and injector screen at least once a year in order to maintain proper operation of the conditioner. Some locations may

require more frequent injector and screen servicing. Refer to Figure 17 and complete the following steps to clean the injector screen and injector:

1. Unplug the power cord.
2. Shut off the water supply or put the bypass-valve(s) into the bypass position and remove the rear cover, Figure 10.
3. Relieve system pressure by opening the rinse drain valve (the fifth valve back from the control) with a screwdriver, Figure 11.
4. Using a blade screwdriver, unscrew and remove the injector screen and injector cap.
5. Clean screen with a fine brush. Flush with water until clean.
6. Using a needle-nose pliers, pull the injector straight out.
7. Flush water into the injector screen recess of the valve body to flush debris out through the injector recess.
8. Clean and flush the injector. Lubricate the o-rings on the injector, injector cap and injector screen with silicone lubricant.

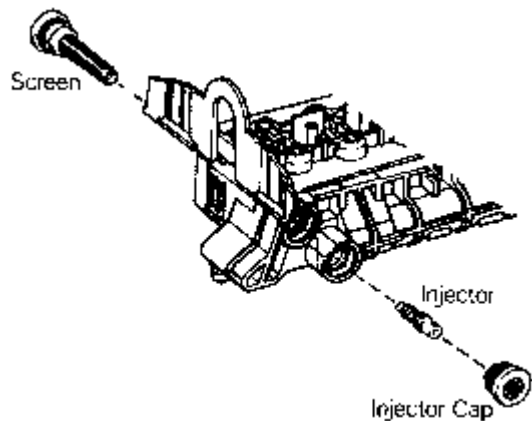

Figure 17

9. Reinstall the injector (small and first), injector cap and injector screen.

Caution

Do not overtighten the plastic cap. Seat the cap lightly into position. Overtightening can cause breakage of the plastic cap which may not be evident immediately.

11. Reconnect electric power, and reset the time of day.

10. Slowly open the water supply valve or return the bypass valve(s) to the not in bypass" position.

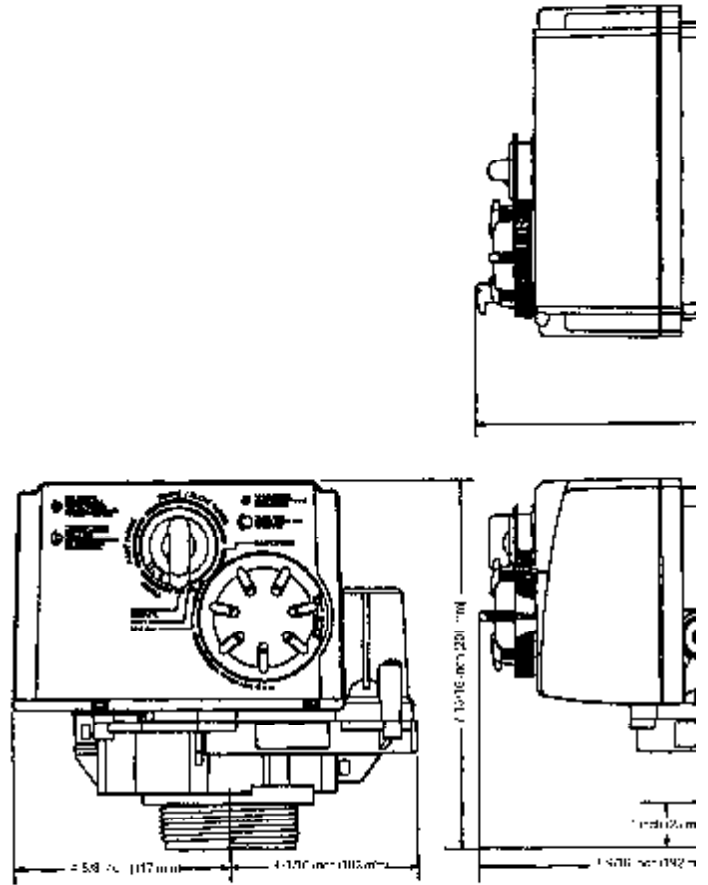

Hydrostatic Test Pressure	300 psi
(2069kPa)	
Working Pressure	20 to 127 psi (138 to 876 kPa), 100 psi max in
Canada	
Voltage	24V 50 Hz, 24V 60 Hz, 100V 50 Hz, 100V 60 Hz, 230V 50 Hz, 115V 60
Hz	
Current	50
mA	
Operating Temperature	34°F (1°C) to 120°F
(49°C)	
Humidity	10% to 100%, condensing
allowed	
Pressure Tank Thread	2 1/2 in - 8
NPSM	
Brine Line Thread	1/4 in NPT
male	
Distributor Tube Diameter Required	13/16 in O.D. (20.6
mm)	

Distributor Tube Length 1 1/4 in (31.8mm) higher than top of mineral tank

Standard Manifold Connection 3/4 in NPT inlet-outlet, 1/2 in NPT drain in NORYL manifold,
 3/8 in NPT drain in brass manifold

Optional Manifold Connections 1 in NPT inlet-outlet, 1/2 in NPT drain; 3/4 in BSPT inlet-outlet, 3/8 in BSPT drain; 1 in BSPT inlet-outlet, 1/2 in. BSPT drain

Optional Bypass Valve 3/4 in (19.1mm) or 1 in (25.4mm) copper tailpiece, 1/2 in NPT male drain

Valve Module, Tank Adaptor, Optional Bypass Valve Reinforced NORYL

Inlet-Outlet Manifold Brass or reinforced NORYL

Rubber Parts Compounded for cold water service

Injector size "A" White Nozzle 0.042 in (1.1 mm) diameter, Throat 0.089 in (2.3 mm) diameter

Injector size "B" Blue Nozzle 0.052 in (1.3 mm) diameter, Throat 0.099 in (2.5 mm) diameter

Injector size "C" Red Nozzle 0.059 in (1.51 mm) diameter, Throat 0.099 in (2.5 mm) diameter

Backwash Controllers Available for 6, 7, 8, 9, 10, 12, 13, 14 in
 (15.2, 17.8, 20.3, 22.9, 25.4, 30.5, 33.0, 35.6 cm) diameter mineral tanks

area
 All sized to flow 4.5 gpm/sq ft (183 l/min/m²) of bed

Pressure Graphs

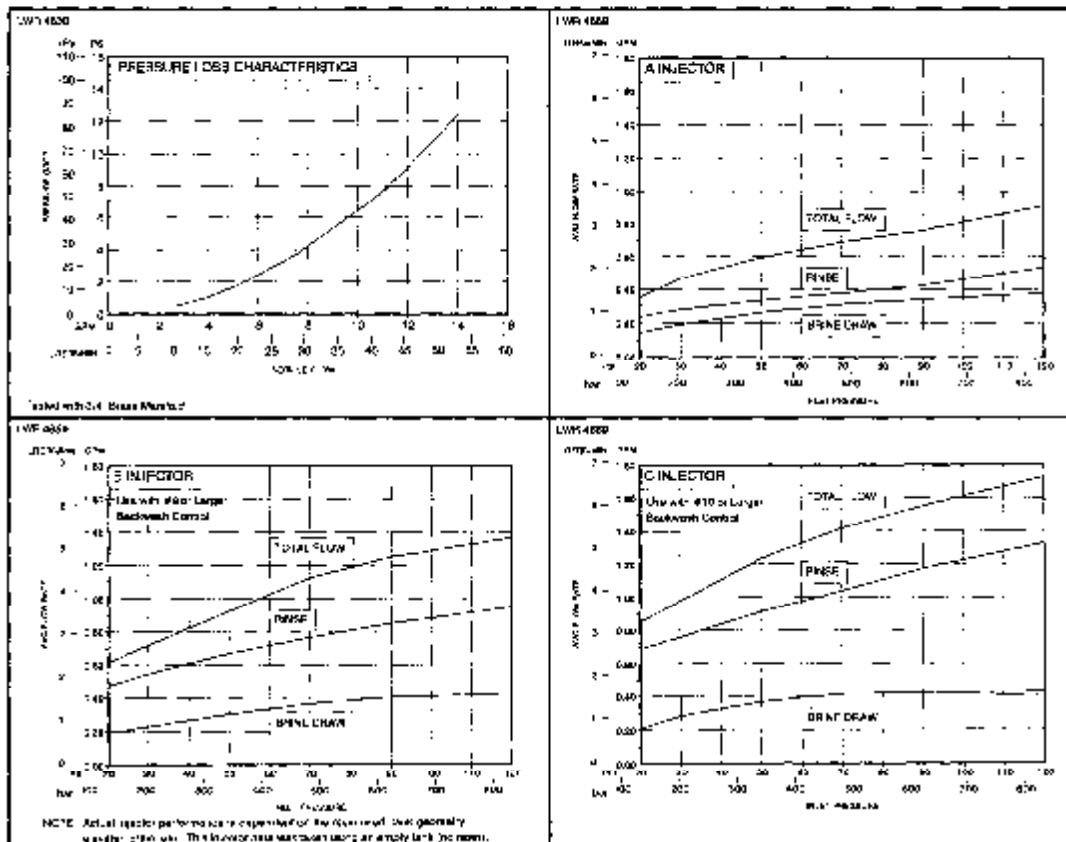

Control Valving Identification

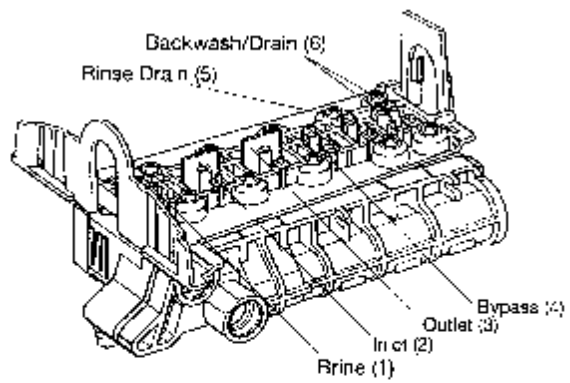

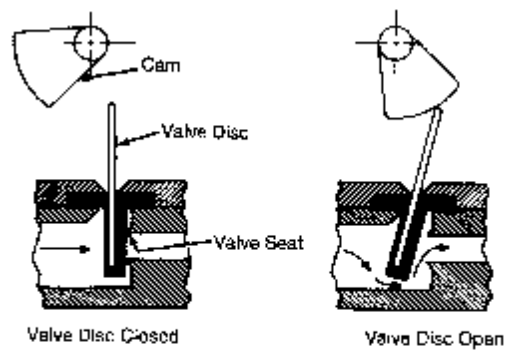

Valve Disc Operation



Flow Diagrams

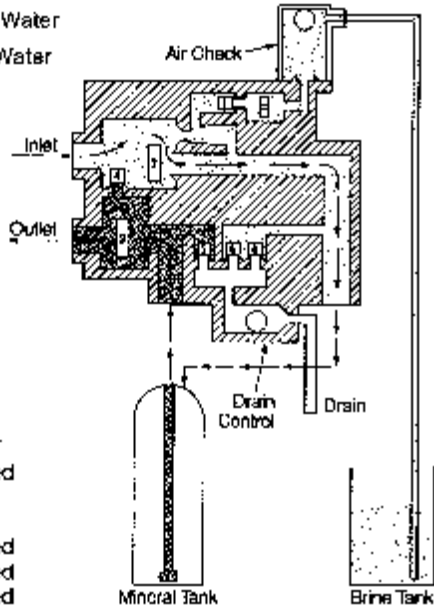

1 Service Position

-  Hard Water
-  Soft Water



- Valve No.
- 1 - Closed
 - 2 - Open
 - 3 - Open
 - 4 - Closed
 - 5 - Closed
 - 6 - Closed

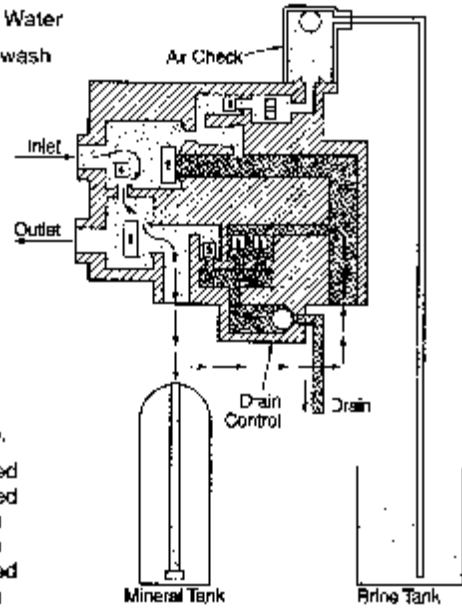

2 Backwash Position

-  Hard Water
-  Backwash



- Valve No.
- 1 - Closed
 - 2 - Closed
 - 3 - Open
 - 4 - Open
 - 5 - Closed
 - 6 - Open

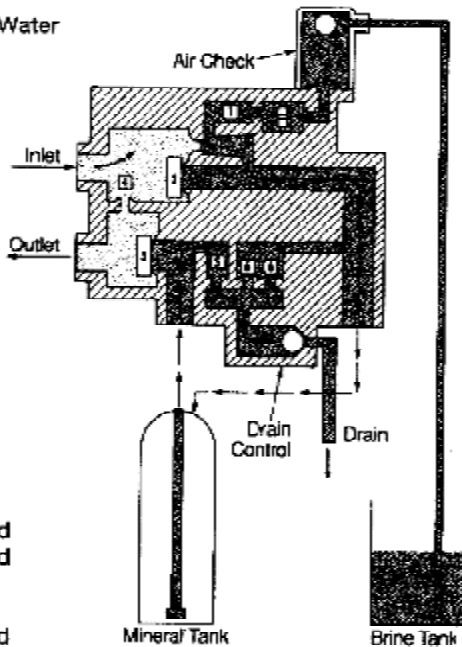

3 Brining Position

-  Hard Water
-  Brine



- Valve No.
- 1 - Open
 - 2 - Closed
 - 3 - Closed
 - 4 - Open
 - 5 - Open
 - 6 - Closed

4 Slow Rinse Position

-  Hard Water
-  Brine

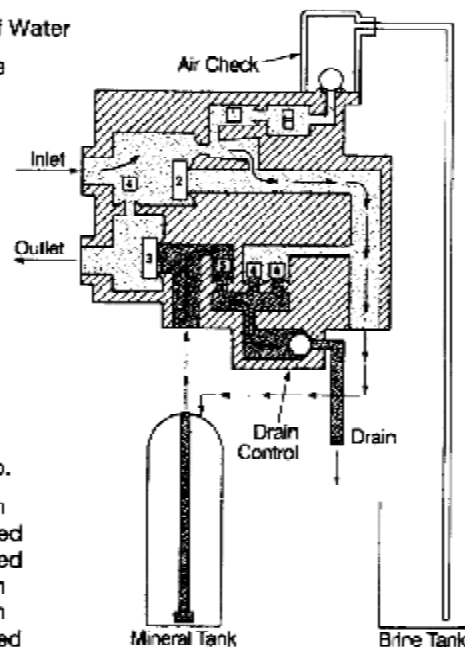

- Valve No.
- 1 - Open
 - 2 - Closed
 - 3 - Closed
 - 4 - Open
 - 5 - Open
 - 6 - Closed

Replacement Parts

940 Timer

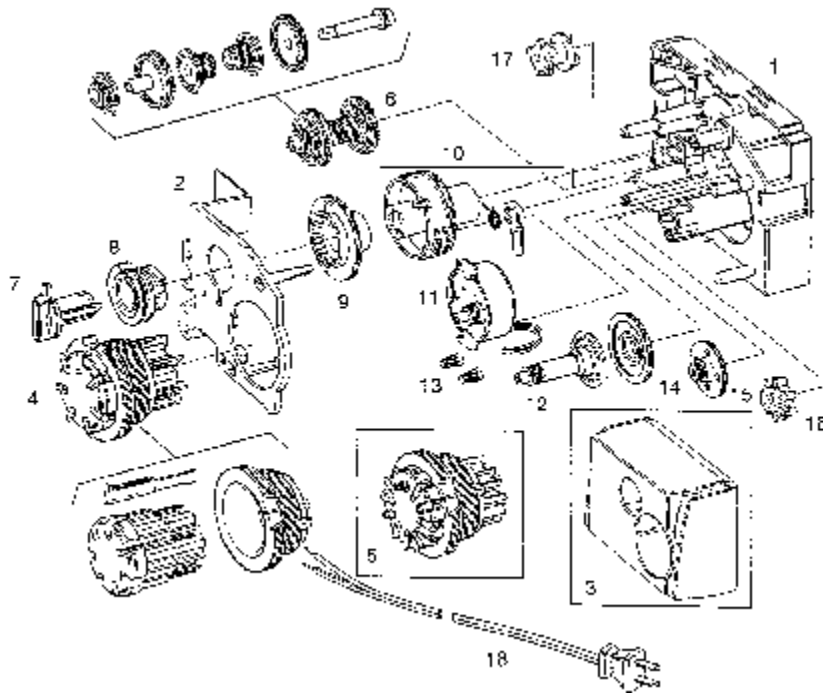

Code	Part No.	Description	Qty	Code	Part No.	Description	Qty
1	1000855	Backplate	1	12	1000841	Clutch Gear	1
2	1000879	Gear Support Plate, 12 - Hour Clock	1	13	1007483	Wire Nut	1
3	1000881	Timer Cover, English Standard 1		14	1000833	Gear	1
4	1000887	7 - Day Calendar Cap Assembly	1	15	1000832	Gear	1
5	1000888	12 - day Calendar Cap Assembly	1	16	1000858	Geneva/Clock	1
6	1000877	Main Drive Stack	1	17	1000844	Geneva/Drive Gear	1
7	1000848	Knob	1	18		Power Cord	1
8	1000857	Salt Dial	1		1000821	North America (Flat 2-Wire)	
9	1000847	Salt Gear	1		1007495	Italy (CEI 23-16/VII)	
10		Main Drive Gear	1		25A292	Continental Europe (CEE 7/7)	
	1000900	Standard Cycle			25A303	United Kingdom (AS 3112)	
	1000901	Water Saver, Economy Cycle			1007496	Australia (AS 3112)	
	1000902	Extra Salt & Long Rinse, Long Rinse Cycle			25A555-001	Japan (JIS 8303)	
	1000903	Adj. Backwash/Standard Cycle			1000822	Lamp Cord, Low Voltage (24V)	
	1000904	Adj. Backwash/Extra Salt Long Rinse, Long Cycle			25A394	North America (US - NEMA 5-15P) (Canada C22.2 No. 42) (Flat 3-Wire)	
	1000905	3 Cycle/Adj. Backwash		*	1000939	Retainer, Calendar Cap (*Not Shown)	
11		Motor Option	1				
	1000802	24V 50 Hz					
	1000803	24V 60 Hz					
	1000804	110V 50 Hz					
	1000805	100V 60 Hz					
	1000806	230V 50 Hz					
	1000807	115V 60 Hz					

Valve Body and Tank Adaptor Module

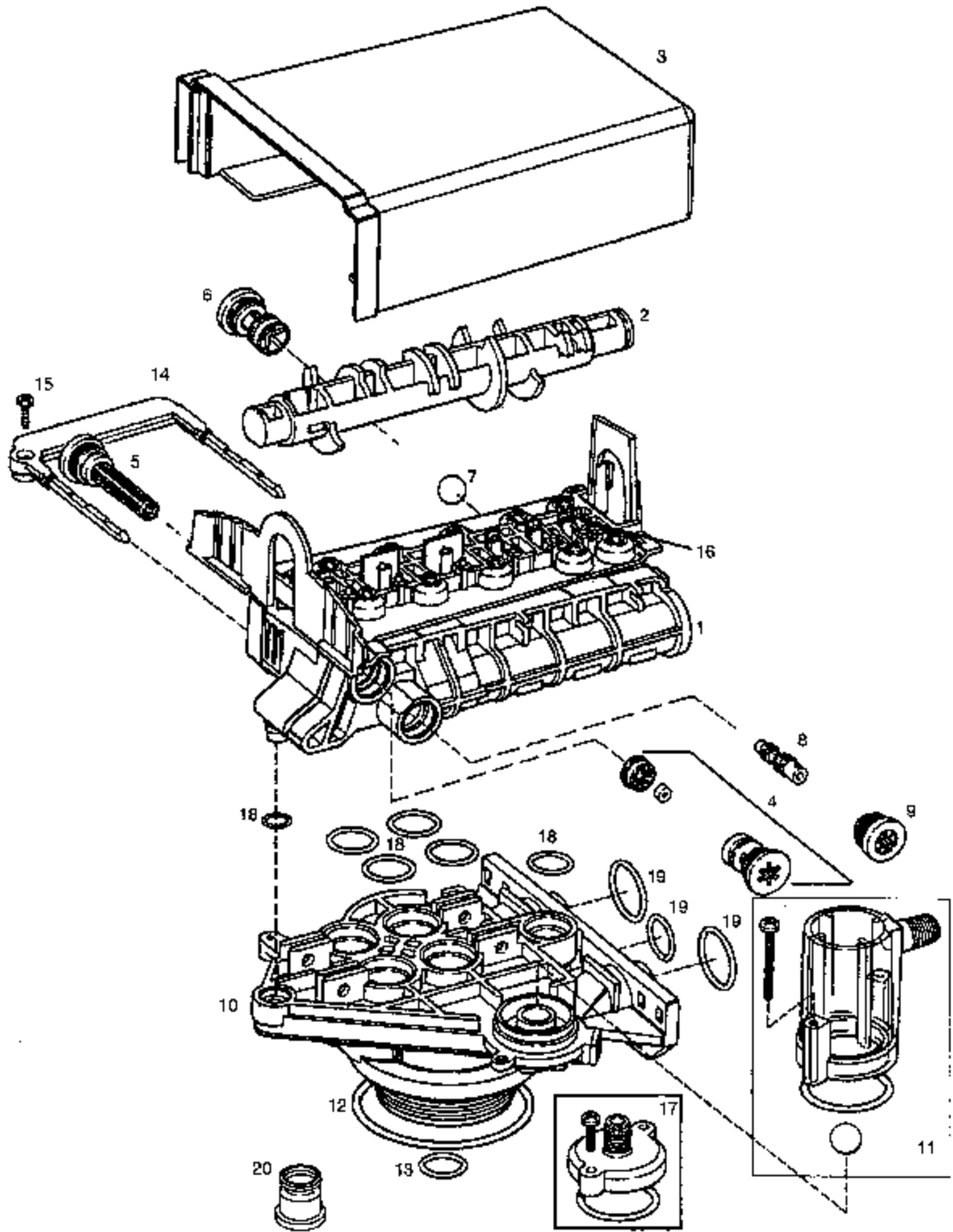

Code	Part No.	Description	Qty	Code	Part No.	Description	Qty
1	1000238	Valve Assy. w/o Flow Controls	1	10	1033784	Tank Adaptor Assy.	1
2	1000824	Camshaft, Std, One-Piece	1	11	1032416	Air Check Ass.	1
3	1000827	Valve Cover, Black	1	12	1010429	O-ring, 3-1/8x3-1/2x3/16 BN	1
4		Brine Refill Flow Control Assy. :	1	13	1010428	O-ring, 3/4x1x1/8 EP	1
	1000221	.14 GPM		14		Locking Bar:	1
	1000222	.33 GPM		1031402	English Language		
	1000223	.40 GPM		15	1006093	Screw, No. 8x9/16 in 1	
5	1000226	Screen/Cap Assy. With O-ring	1	16	1001580	Spring, Valve Discs	9
6		Backwash Control Assy. With O-rings:	1			Kits:	
	1000209	No. 7 for 7 in Diameter Tank		17	1033066	New to Old Air Check Adaptor	
	1000210	No. 8 for 8 in Diameter Tank		*	1000250	Valve Discs Replacement	
	1000211	No. 9 for 9 in Diameter Tank				(*Not Shown)	
	1000212	No. 10 for 10 in Diameter Tank		18	1001404	O-ring Group: Tank Adaptor	
	1000213	No. 12 for 12 in Diameter Tank		19	1040459	O-ring Group: Piping Boss	
	1000214	No. 13 for 13 in Diameter Tank		*	1000252	Severe Service Valve Discs	
	1000215	No. 14 for 14 in Diameter Tank				(*Not Shown)	
7	1030502	Ball, Flow Control	1	20	1041010	Optional Riser Insert 13/16	
8		Injector Assy. With O-rings	1				
	1032970	"A" Injector - White					
	1032971	"B" Injector - Blue					
	1032972	"C" Injector - Red					
9		Injector Cap With O-rings	1				
	1000217	"A" Cap					
	1000218	"B" Cap					
	1000219	"C" Cap					

Bypass Valve and Piping Boss

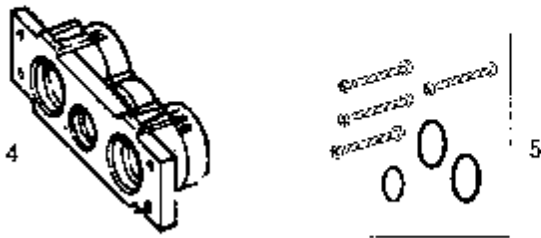
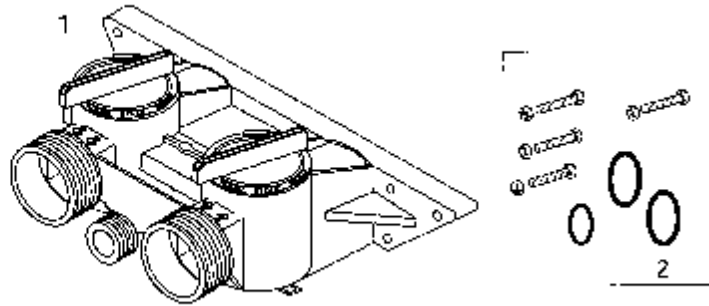

Code	Part No.	Description	Qty
1	1040769	Bypass Body Assy	1
2	1040524	Installation Kit:	
3	1001606	3/4 in Copper Tube Adaptor Kit 1	
	1001670	1 in Copper Tube Adaptor Kit	1
	1001608	22mm Copper Tube Adaptor Kit	1
	1001609	28mm Copper Tube Adaptor Kit 1	
	1001613	3/4 in CPVC Tube Adaptor Kit	1
	1001614	1 in CPVC Tube Adaptor Kit	1
	1001615	25mm CPVC Tube Adaptor Kit 1	
	1001769	3/4 in NPT Plastics Pipe Kit	1
	1001603	1 in NPT Plastics Pipe Kit	1
	1001604	3/4 in BSPT Plastic Pipe Adaptor Kit	1
	1001605	1 in BSPT Plastic Pipe Adaptor Kit	1
	1001611	3/4 in BSPT Brass Pipe Adaptor Kit	1
	1001610	1 in NPT Brass Pipe Adaptor Kit	1
	1001612	1 in BSPT Brass Pipe Adaptor Kit	1

Code	Part No.	Description	Qty
		Piping Boss	
4	Kit	Piping Boss (Includes Hardware)	
	1040277	3/4 in NPT, Brass, 3/8 in NPT Drain	
	1040278	1 in NPT, Brass, 1/2 in NPT Drain	
	1040281	3/4 in BSPT, Brass, 3/8 in BSPT Drain	
	1040282	1 in BSPT, Brass, 1/2 in BSPT Drain	
	1040279	3/4 in NPT, Noryl, 1/2 in NPT Drain	
	1040280	1 in NPT, Noryl, 1/2 in NPT Drain	
	1040283	3/4 in BSPT, Noryl, 1/2 in BSPT Drain	
	1040284	1 in NPT, Noryl, 1/2 in NPT Drain	
5	1040339	Piping Boss Installation Kit	

Troubleshooting

The technology upon which the Series 255/940 control is based, is well established and proven in service over many years. However, should a problem or question arise regarding the operation of the system, the control can be very easily serviced. The control module can be quickly replaced or adjustments can be made at the installation. For parts mentioned, refer to exploded views in the **Replacement Parts** section of this manual.

IMPORTANT: Service procedures that require the water pressure to be removed from the system are marked with a ! after the possible cause. To remove water pressure from the system, put the bypass valve or three-valve bypass into the bypass position and open the Rinse Drain Valve (the fifth valve back from the control) with a screwdriver, Figure 11. Restore system water pressure when the service work is completed.

Problem	Cause	Solution
1. Control will not regenerate automatically	<ul style="list-style-type: none"> a. Electric cord unplugged b. Defective Timer motor c. Day pins not down on calendar cap. d. Binding in gear train of timer 	<ul style="list-style-type: none"> a. Connect power b. Replace motor c. Depress pins for days regeneration required d. Replace timer
2. Control regenerates at Wrong time of day	<ul style="list-style-type: none"> a. timer set incorrectly. 	<ul style="list-style-type: none"> a. Correct setting according to Instructions.
3. Control will not draw Brine.	<ul style="list-style-type: none"> a. Low water pressure. b. Restricted drain line. c. Injector plugged. ! d. Defective injector. ! e. Valve disc 2 and/or 3 not closed. f. Air check prematurely closed. 	<ul style="list-style-type: none"> a. Water pressure must be 20 psi minimum. b. Remove restriction. c. Clean injector and screen. d. Replace injector cap. e. Flush out foreign matter holding disc(s) open by manually operating valve stem(s). Replace if needed. f. Put control momentarily into brine refill. replace or repair air check if needed. Refer to Brine Line Connection.
4. Brine tank overflow.	<ul style="list-style-type: none"> a. Brine valve disc1 being held open By foreign matter. b. Uncontrolled brine refill flow rate. c. Valve disc 2 and/or 3 not closed During brine draw causing brine refill d. Air leak in brine line air check. e. Improper drain control for injector. 	<ul style="list-style-type: none"> a. Flush out foreign matter holding disc open by manually operating valve stem. b. Remove and clean brine refill flow control. c. Flush out foreign matter holding disc(s) open by manually operating valve stem(s). d. Check all connections in brine line for leaks. Refer to Brine Line Connection. e. Too small of a drain control with a "B" or "C" injector will reduce draw rates. Reference Pressure Graphs.
5. System using more or less salt than salt control Is set for.	<ul style="list-style-type: none"> a. Inaccurate setting. b. Foreign matter in controller Causing incorrect flow rates. c. Defective controller. ! 	<ul style="list-style-type: none"> a. Make correct setting b. Remove salt controller and flush out foreign matter. Manually position control to brine draw to clean controller. After so doing, position control to "brine/slow rinse" to remove brine from tank. c. Replace defective part.

6. Intermittent or irregular brine draw .	a. Low water pressure. b. Defective Injector. !	a. Water pressure must be 20 psi Minimum. b. Replace both injector and injector cap.
7. No conditioned water After regeneration.	a. Unit did not regenerate b. No salt in brine tank c. Plugged injector. d. Air check prematurely closed.	a. Check for power. b. Add salt to brine tank. c. Remove injector and injector screen, Flush with water. d. Put control momentarily into brine refill To free air check. Replace or repair air check if needed. Refer to brine line connection.
8. Control backwashes at Excessively low or high Rate.	a. Incorrect back wash controller. ! b. Foreign matter effecting controller Operation. !	a. Replace with correct size controller. b. Remove and clean controller seat and Ball.
9. Flowing or dripping Water at drain or brine Line after regeneration.	a. Drain valve (5 or 6) or brine valve (1) held open by foreign matter or particle. b. Weak valve stem return spring on Top plate.	a. Manually operate valve stem to flush Away obstruction. b. Replace spring.
10. Hard water leakage During service.	a. Improper regeneration. b. Leaking external bypass valve. c. O-ring around riser tube Damaged. d. Leaking past bypass valve disc.	a. Repeat regeneration making certain Correct salt usage is used. b. Replace o-ring. c. Replace o-ring. d. Replace defective part.

Disinfection of Water Conditioners

The construction materials of the water conditioner system do not support bacterial growth or contaminated the water supply. However, we recommend that the conditioners be disinfected after installation and before the conditioners are used to treat potable water. In addition, a conditioner can become fouled with organic matter during normal usage or with bacteria from the water supply. Periodic disinfection is recommended for all conditioners. Use one of the following methods of disinfection based on operating conditions, style of conditioner, type of ion exchange, and disinfectant available.

Sodium Hypochlorite

Sodium Hypochlorite, 5.25% solutions, can be used with polystyrene resin, synthetic gel zeolite, greensand, and bentonites and are available under trade names such as Chlorox, Linco, Bo Peep, White Sail and Eagle Brand Bleach. Adjust the dosage if stronger commercial solutions are used.

The recommended dosage for 5.25% solution is:

- Polystyrene resin: 1.2 fluid ounces per cubic foot.
- Non-resinous exchangers: 0.8 fluid ounces per cubic foot.

Complete the following steps to disinfect the conditioner: Add the sodium hypochlorite solution to the brine well of the brine tank. Make sure that the brine tank has water in it so the solution is carried into the conditioner. Proceed with normal regeneration. Refer to the **Manual Regeneration** section for this manual.

Calcium Hypochlorite

Calcium Hypochlorite, 70% available chlorine, is available in several forms including tablets and granules. These solid materials can be used directly without dissolving before application.

The recommended dosage for Calcium Hypochlorite is two grains (approx. 0.1 ounce) per cubic foot.

Complete the following steps to disinfect the conditioner: Add the Calcium Hypochlorite to the brine well of the brine tank. Make sure that the brine tank has water in it so the solution is carried into the conditioner. Proceed with normal regeneration. Refer to the **Manual Regeneration** section of this manual.