



A 1700 24 Hour Programmable Timer

OPERATING INSTRUCTIONS



This simple to operate digital timer allows numerous variations of ON/OFF cycles every 24 hours. It can be configured to 14 on cycles every day. Additionally, it may be programmed to operate on any combination of days (ie. weekdays or weekends). The on duration is variable and can be set from 1 second to 23 hours 59 minutes and 59 seconds. It is ideal for programming period breaks in schools or change of shift bells in factories and work places. The in-built digital clock can be set to one of three modes of operation, **manual**, **automatic** and **off**. In the manual mode you may override any programmed setting, the automatic mode switches on at the pre-programmed times and the off mode disables the pre-programmed on times.

FEATURES

- 19" 2U Rack mount or desk mount
- Timer may trigger Chime or 24VDC out
- Choice of 240VAC or 24VDC operation
- Choice of 5 tones for the bell chime
- In-built manually operated Alert/ Evac switches
- Remote trigger contacts for Alert, Evac and Chime
- Programs are retained during power failure
- Up to 14 "ON" programs per 24 hours
- Unit may be programmed to operate on any combination of days
- 2 Year warranty
- Made in Australia

OPERATING INSTRUCTIONS

To install and operate the unit you will need to programme the timer as follows.

1) Set the current time and day .

To set the current day or time press the \otimes key to clear the entire memory. Hold down the **CLOCK** key and press either the **DAY**, **HOUR**, **MIN** or **SEC** key continuously until the desired day or time is shown. Then lift your finger off the **CLOCK** key to start the timer operating.

2) Set the "ON" duration for all programs

Press **TIMER** key, the display will show :



Set the duration of all the programs (T1) by pressing **HOUR**, **MIN** and **SEC** keys until the desired "ON" duration is displayed. It is recommended that you use durations of no more than 1 second for a single chime tone. For longer chime durations you will need to set dip switch 3 to ON as well as programming the ON duration for a longer period.

To review the programmed duration, press the timer button when in timer function.

3) Set the programmed "ON" times.

After setting the ON duration, press the **TIMER** button again to bring up the first "ON" program.

Use **HOUR**, **MIN** and **SEC** buttons to set the first program start time. Use the **DAY** button to set the desired day or sequence of days this program will operate on.

You may then press **TIMER** again to set the "ON" time for programs 2 - 14.

Distributed by Altronic Distributors Pty. Ltd. Perth. Western Australia.

Proudly Assembled in Australia

REDBACK A 1700 Programmable Timer

To exit programming press the CLOCK button , this will return you to the timer function.

To review a programmed "ON" time press the TIMER button until the program you wish to alter is displayed.

4) Switch the unit to "Auto" mode.

For the programmed "ON" times to operate the unit must be switched to Auto mode. Use the button marked MANUAL until the dash indicator is above the word AUTO. In this mode the programs will function at the prescribed times and days.

5) Use of Manual or Off

Manual operation allows the user to override a program.

To use the timer in manual mode press the MANUAL key until the dash indicator is over the word On.

This will turn the timer on. The timer will stay triggered until you manually set the timer to the "OFF" position.

To set the timer to the off position press the MANUAL key until the dash indicator is over the word Off.

OFF.

REAR WIRING CONNECTIONS

The connections on the rear of the unit require some explanation in order to set up for continuous trouble free use.

The 10 way pluggable terminal is labelled Evac, Alert, Chime, 24V Out and Timer 24V Out.

The terminals activate the assigned tone, e.g. if you want the ALERT to sound from a remote location the contacts may be connected to a normally open switch which when pressed will trigger the ALERT tone and will then sound as if the ALERT button on the front panel was pushed, and the same applies to the EVAC and CHIME terminals.

The 24VDC switched out terminal has no output until a button or the timer activates a tone. When a tone is activated 24VDC is present across the positive and negative terminals .

TABLE 1 : DIP SWITCH SETTINGS

Switch Number	1	2	3	4
Chime Tone: Single Bing	OFF	OFF	OFF	-
Bing Bong	OFF	OFF	ON	-
Single Bong	ON	OFF	OFF	-
Siren	ON	ON	OFF	-
Deedle Tone	OFF	ON	OFF	-
*Repeating Bong	ON	OFF	ON	-
*Repeating Siren	ON	ON	ON	-
*Repeating Deedle	OFF	ON	ON	-

* These tones will sound continuously for the duration of the timer or as long as the chime button is pressed.

Chime Tone Switch Settings

To set the tone for "ON" cycle , use the dip switch setting table to obtain the type of tone you wish to output.

The factory setting for the chime tone will be single Bing.

Dip switch 4 makes the alert/evac tone cycle continuously after it is triggered or stay on only while the Alert/evac button is held down.

To enable the alert /evac to operate continuously switch dip switch 4 to ON. Note that this will be factory set to

There is a switch next to the Timer 24V Out terminal on the rear of the unit. This allows you to select whether the timer "ON" cycle triggers the Timer 24V out contacts or the chime. If this switch is in the "Up" position , the timer will cause 24VDC to appear across the "Timer 24V out " contacts. In the "Down" position , the timer will trigger the chime.

Note : this switch will be factory set to "Down".

The RCA Sockets are line level (1V) outputs, which are run to an amplifier or mixer input.

Power Supply

The power for the unit may come from either 24VDC or 240 AC , for 240V operation simply plug the 240V power cord into the socket labelled 240VAC.

For 24VDC operation , use the terminal marked 24VDC.

Caution: The 24VDC is polarised and may cause damage to the unit if not connected correctly. The polarity is marked on the unit, just under the terminal.

Power only needs to be in one form either AC or DC to work. Both 24VDC and 240VAC can be connected at the same time (for battery backup).

Volume Controls

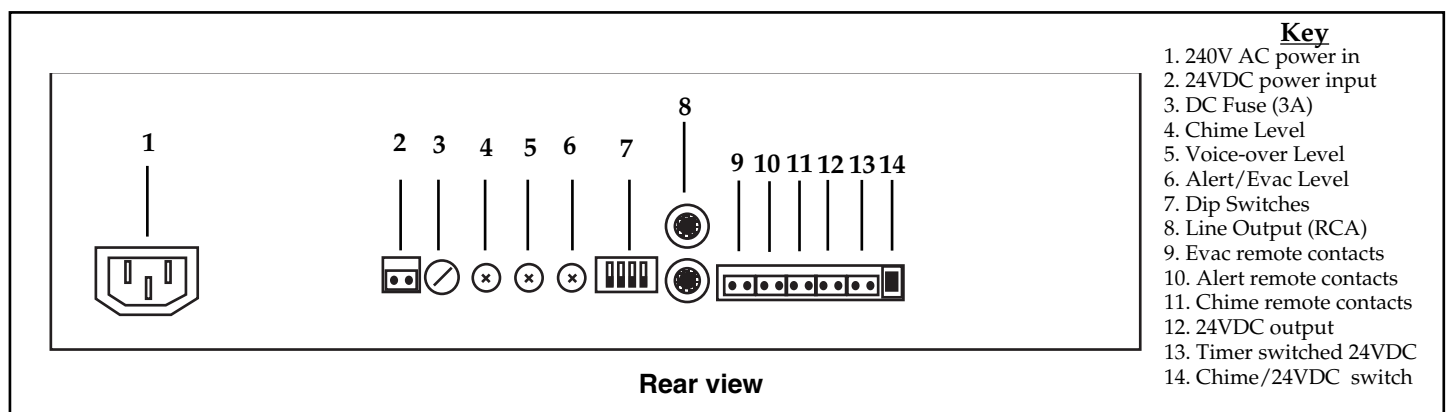

The volume controls can be found on the rear of the unit, these should be adjusted with a small phillips head screw-driver or adjustment tool.

Chime Volume controls the output level of the Chime.

Voice Over controls the level of the optional Voice Over module (A 2072) if installed.

Alert/Evac Volume controls the level of the Alert and Evac tones.

Adjust the output volumes to the desired levels.

THE OPTIONAL VOICE OVER MODULE

The A 1700 timer panel has the option to fit the A 2072 voice over module. This will add a voice message to the evacuation cycles when the evacuation cycle is triggered.

Use with the A 1700 Timer and tone generator

Connection to the A 1700 is via the 5 way keyed header cable (JP1). The Voice-over Module will play a recorded message twice in succession after every four evacuation cycles. The volume control on the A 1700 Timer, labelled "Voice over level" is used to vary the volume ratio between the evacuation tones and the voice playback.

5 Pin Header (JP1) Pinouts

Pin	Function	Description
1	Vcc	Regulated +5V input*
2	GND	Ground 0V
3	AUDIO	Audio output, line level 10kΩ
4	PLAY	A momentary high to activate the message playback
5	PLAYING	This line goes low to indicate a message is currently being played

BATTERY REPLACEMENT

Periodically the CR2302 lithium battery located within the time clock (Altronics part No. S 4999) should be replaced, this should not be necessary to be done more often than once in 4- 5 years, or should the timer begin to lose programs or time. To replace the lithium battery in the unit, disconnect power to the unit. Open the lid and peel off the label on the rear of the timer. You will then see a screw type battery cover. Un-screw this cover and remove the old battery. Checking that the orientation is correct place the new battery in the timer and screw down the cover. The panel should now have a reading on the display.

You will need to re-programme the settings on the timer (refer to that part of the operating section for instructions on re-programming the settings on the timer).

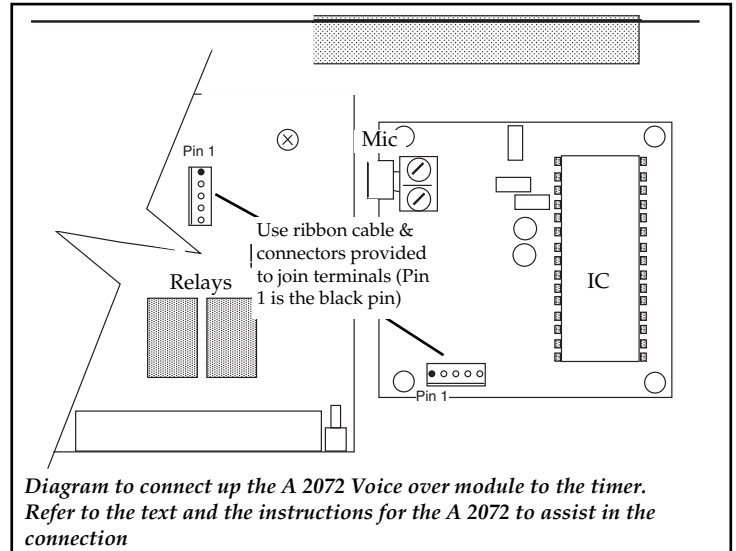

Diagram to connect up the A 2072 Voice over module to the timer. Refer to the text and the instructions for the A 2072 to assist in the connection

TROUBLESHOOTING

UNIT DOES NOT SWITCH ON AT THE REQUIRED HOUR

Check programs for the correct switch on times.

Check timer for the correct time.

UNIT DOES NOT SWITCH OFF AFTER THE ELAPSED TIME

Check timer for the correct "ON" time.

NO POWER TO UNIT

Check DC fuse.

Check power switch is on and confirm unit is plugged in to either 24VDC or 240VAC.

TIMER FAILS TO TRIGGER TONE / 24V OUT

Check that the timer 24VDC out switch is set correctly.

Check line out connections to amplifier / preamp.

Check connections to timer 24VDC out terminals.

TIMER FAILS TO DISPLAY OR KEEP CORRECT TIME

Replace battery in timer.

ALERT/ EVAC CONTINUE TO OPERATE AFTER THE SWITCH IS RELEASED

Check dip switch settings.

INCORRECT TYPE OF TONE SOUNDING WHEN CHIME IS PUSHED

Check Dip switch settings

EVAC, CHIME OR VOICE OVER LEVEL TOO LOW

Adjust volume controls.

REDBACK A 1700 Programmable Timer

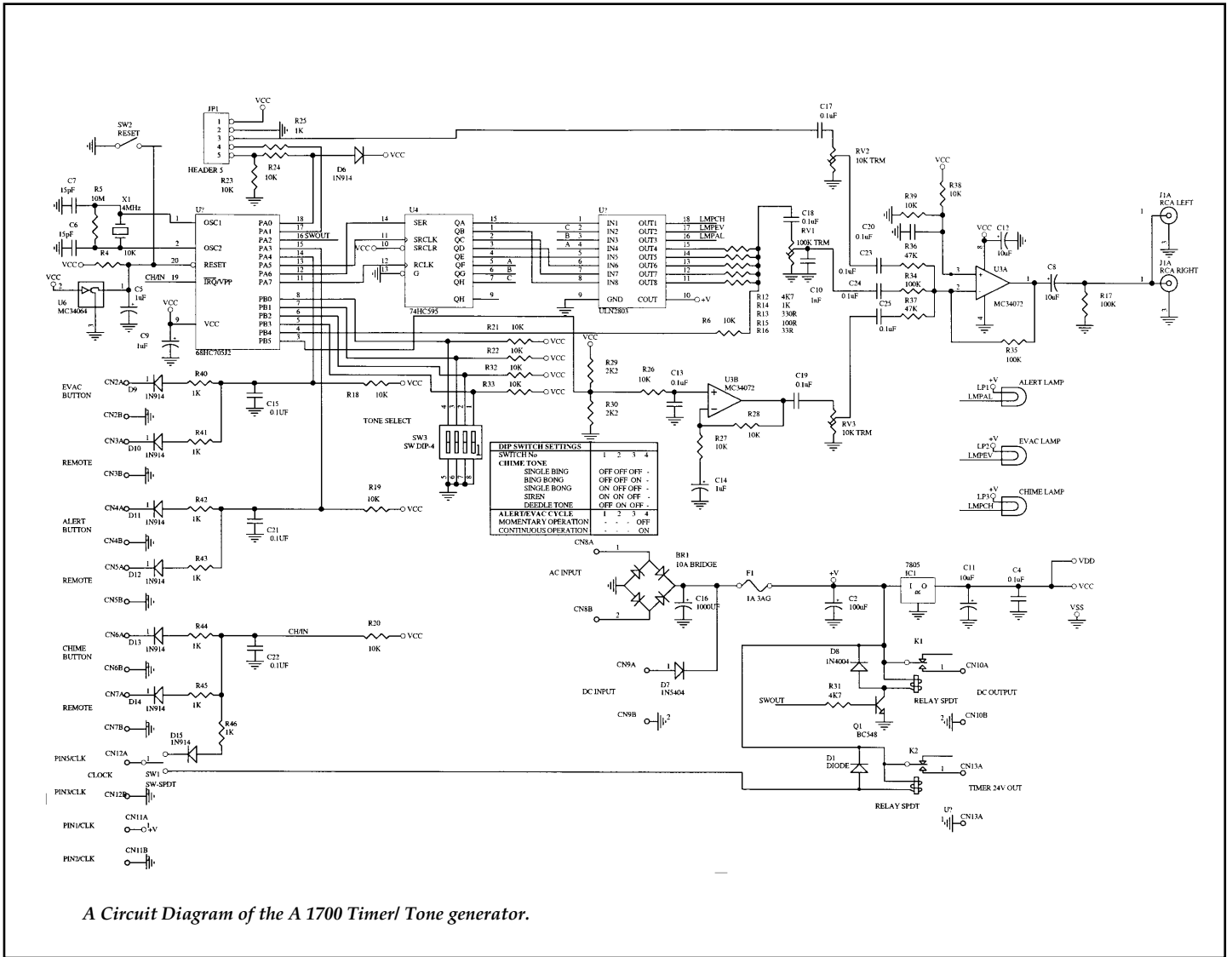

A Circuit Diagram of the A 1700 Timer/ Tone generator.

Not field serviceable: For repair contact Altronic Distributors Pty. Ltd. Perth W.A. 6000 Phone: (08) 9428 2199 Fax: (08) 9428 2198

SPECIFICATIONS

OUTPUT LEVEL:1V (Line level)
DISTORTION:0.01%
FREQ. RESP.:140Hz - 20kHz
SIGNAL TO NOISE RATIO:
 Alert/Evac/Chime:-70dB typically
OUTPUT CONNECTORS:
 Audio Output:RCA Stereo Socket
 Switched 24V DC Out:Pluggable Terminals
 Timer activated 24V DC Out: .Pluggable Terminals
INPUT CONNECTORS:
 24V DC Power:Pluggable Terminals
 240V AC Power:IEC Chassis Socket
 Remote Alert, Evac, Chime:Pluggable Terminals
CONTROLS:
 Day, Hour, Minute, Second
 Clock, Manual/ Auto/ Off setTimer controls

Tone Selection /
Alert Evac operationDip Switches
Alert, Evac, Chime, Voice over:Rear Volume
Power:On/Off Switch
Alert Switch:Illuminated Push Switch
Evac Switch:Illuminated Push Switch
Bell / Chime Switch:Illuminated Push Switch
Cancel Switch:Push Switch
INDICATORS:Power on LED
POWER SUPPLY:240V AC or 24V DC
DIMENSIONS:≈ 482W x 152D x 44H
WEIGHT:≈ 2.3 kg
COLOUR:Black
OPTIONS:A 2072 Voice Over Module

* Specifications subject to change without notice.

Distributed by Altronic Distributors Pty. Ltd. Perth. Western Australia.
 Phone: 1300 780 999 Fax: 1300 790 999
 Internet: www.altronic.com.au