

ROBATHERM

Proudly Distributed By
ROBAND AUSTRALIA PTY LTD



OPERATING INSTRUCTIONS

DOUBLE-SKINNED PERCOLATOR

Models: **CP60** **Version 1**

Includes

International models: **...-UK and ...-F**



These instructions cover the models of ROBATHERM® Percolators listed above. Although there are slight variances between them, the installation, care and maintenance procedure is the same for all.

Roband® Australia is a wholly Australian owned company and has been manufacturing quality commercial catering equipment for the food service industry for more than 50 years. Roband products are engineered and manufactured to the highest standards to provide functionality, reliability and durability, and our quality products are exported world-wide.

Included in the comprehensive Roband® range are Toasters, Fryers, Milkshake Mixers, Rotisseries, Food Display Cabinets and much more.

Roband® Australia also acts as the Australian agents for Vitamix® Blenders, Noaw® Meat Slicers, Förje® Cookware, Robalec™ Soup/Rice Warmers, Robatherm Urns, Austheat® Fryers, Dipo Induction & Autofry Machines. Roband also has its own line of commercial cookware and cutlery under the Robinox® brand name.

For a complete set of brochures please contact your nearest authorised dealer or contact Roband directly at our head office.

Roband Head Office Sydney, Australia			
Roband Australia Pty Ltd 1 Inman Road Dee Why NSW 2099 AUSTRALIA		Tel:	+61 2 9971 1788
		Fax:	+61 2 9971 1336
		Email:	sales@roband.com.au
		Web:	www.roband.com.au
International Agents For additional agents please email Head Office			
Cyprus:	United Catering Equipment Supplies Ph: +357 777 777 24	Switzer-land:	Burgi Infra Grill Ph: +41 418 554 552
Fiji:	Hotel Equipment Ltd Ph: +679 672 0666	Thailand:	Seven Five Distributors Co Ltd Ph: +662 866 5858
Hong Kong:	Chung Wah Kitchen Machine Ltd Ph: +852 2334 5411	United Arab Emirates:	Boncafe Middle East LLC +9714 282 8742
Malaysia:	Allied Food Equipment Ph: +603 9133 5833	United Arab Emirates:	Nisa Trading LLC +9714 396 6132
Maldives:	Radiant Heat Maldives Pty Ltd Ph: +960 333 4845	United Kingdom:	Metcalfe Catering Equipment Ph +44 1766 830 456
New Zealand:	Roband New Zealand Ph: +649 274 1354	USA:	Condon & Fisher International Ph: +1 508 361 9226
Noumea:	Comptoir Materiel Professionnel Ph: +687 28 50 43	USA:	Condon & Fisher International Ph: +1 508 361 9226
Papua New Guinea:	Brian Bell & Company Pty Ltd Ph: +675 325 5411	NETHERLANDS:	AKB Bert Muller Ph: +31 306 017 442
Singapore:	Allied Foodservice Equipment Ph: +65 62525880	GREECE:	K&N Engineers Ltd Ph: +30 210 520 0440

© Copyright 2014 – Roband® Australia Pty Ltd

All rights reserved. No part of this work may be reproduced or copied in any form or by any means, electronic or mechanical, including photocopying or posting to a website, without the written permission of the publisher. The material contained within this document is intended entirely for instructional purposes.

CONTENTS

INTRODUCTION	1
PACKAGING	1
COMPLIANCE	1
GENERAL SAFETY	2
PERCOLATOR SAFETY	3
LIABILITY	3
INSTALLATION	4
OPERATION.....	5
PERCOLATOR DIAGRAM	8
COFFEE MEASUREMENT TABLE	9
CLEANING, CARE & MAINTENANCE	10
TROUBLESHOOTING.....	11
SPECIFICATIONS.....	12
CIRCUIT DIAGRAM.....	12
SPARE PARTS LIST	13
EC DECLARATION OF CONFORMITY.....	15
WARRANTY	16

INTRODUCTION

Congratulations on your purchase of this quality **ROBATHERM®** product. With proper care and management your new purchase will give you years of service.

By reading these instructions carefully you can ensure that this machine is used and maintained properly, helping your new investment to perform well for you now, and to continue performing.

PACKAGING

All care is taken when packing and Roband Australia ensures that every unit is functional and undamaged at the time of packaging.

The Package of this Coffee Percolator should include:

- 1) One Coffee Percolator
- 2) One Lid
- 3) One Coffee Basket
- 4) One Percolator Tube (maybe already connected to Coffee Basket)
- 5) This Manual
- 6) Packaging Materials

Any damage to the machine as a result of freight must be reported to the Freight Company and to the agent responsible for the dispatch of said unit within 24 hours of receipt. No claims will be accepted or entertained after this period.



Robatherm™ products have been designed and manufactured to comply with any and all specifications set out by the Australian Communications and Media Authority (ACMA) in regards to Electromagnetic Compatibility. As testament to such compliance these units bear the RCM symbol.

For further information contact the Australian Communications Authority, PO Box 13112, Law Courts, Melbourne VIC 8010.

This Percolator CE compliant. See the EC DECLARATION OF CONFORMITY at end of this document.



⚡ SAFETY ⚡

GENERAL SAFETY



- This machine must only be operated by qualified person(s) who are fully versed in the operating and safety instructions described in this manual.
- This machine contains no user-serviceable parts, other than those described in the Cleaning, Care and Maintenance section.
- The machine should be disconnected from all power and allowed to cool before filling, handling and cleaning.
- Roband Australia, one of our agents, or a similarly qualified person(s) should carry out any and all repairs. Any repair person(s) should be instructed to read the Safety warnings within this manual before commencing work on these units.
- Do not use for any applications outside the scope of these instructions
- Do not remove any cover panels that may be on the machine, unless being repaired by authorized repairer. Sharp edges may exist inside the machine; repairers should take care when servicing the machine.
- Care has been taken when designing these machines to limit external surface temperatures. In normal operation at 25°C the surface temperature of the body should not exceed 60°C, due to the double-skinned design. Note that dangerously high temperatures will occur on the lid as the steam vapour rises – for this reason we have placed additional warnings.
- When cleaning DO NOT immerse the percolator in water or use a water jet. When cleaning always ensure the machine is off and disconnected from the wall power point.
- Allow a 100mm spacing between the machine and any surrounding structure or device. If the machine is near particularly heat-sensitive materials common sense should be employed in determining sufficient distancing.
- Always ensure the power cable does not lie against other hot machines in the kitchen, or is jammed or kinked hard up against other surfaces.
- Protect from rain if used outdoors, and do not place the urn in a salty environment
- Conduct a Hazard Assessment for each individual site installation



SAFETY



PERCOLATOR SAFETY

- Particular care must be taken when dispensing hot or boiling water. Serious burns could occur if used carelessly. **Ensure the percolator is never left unattended around children or the inept.**
- **Do not position the percolator with the tap protruding over the edge of a table.** Small children could reach up and grab the tap, causing horrific burns. The tap will also be in danger of being knocked and/or damaged by passing traffic/trolleys.
- Ensure that the cup used during dispensing is designed for hot liquid use.
- DO NOT carry the unit when filled with water to more than half the maximum capacity to avoid injury. It is too heavy.
- DO NOT carry the Urn before it has cooled down to avoid burns.
- DO NOT tilt the machine over too far whilst it contains water.
- DO NOT open the lid whilst in operation.

LIABILITY

Roband Australia will accept no liability if;

- Non-authorized personnel have tampered with the machine.
- The instructions in this manual have not been followed correctly.
- Non-original spare parts are used.
- The machine is not cleaned correctly, with the right product.
- There is any damage to the unit.

INSTALLATION

- Remove all the packaging materials and tape, as well as any protective plastic from the machine. Clean off any glue residue left over from the protective plastic or adhesive tape using methylated spirit.
- Place the Percolator on a solid, flat level surface with the tap facing the user. It is highly recommended to position the Percolator with the tap away from the edge of the table or bench in order that small children do not reach up and accidentally burn themselves.
- Before connecting the Percolator to the power supply, ensure that the “ON/OFF” switch is set to the “OFF” position
- Connect the Coffee Percolator to standard, single phase, 10 Amp power point. We recommend that the electrical circuit supplying the power point be protected by an approved RCD earth leakage device. Ensure no water has splashed on the plug.
- Before using the percolator for the first time, it is recommended to clean the urn to remove any manufacturing or packaging residue – *see Cleaning*
- National Standards exist outlining the positioning, spacing and ventilation requirements when installing new appliances. These Standards should be consulted and new equipment should be installed accordingly. We would recommend that a well-ventilated air gap of not less than 100mm be maintained. If the machine is near particularly heat-sensitive materials common sense should be employed in determining sufficient clearance.
- Place additional signage and/or protection around the machine if a Hazard Assessment for the installation requires.
- Do not attach any other items to this machine, or use contrary to what is described in this manual.

OPERATION

This Robatherm Percolator is designed to brew coffee (or tea) using the process of percolation. Once brewed the coffee (or tea) will be kept warm. The percolator allows easy dispensing into a cup or small pot. Do not use the machine in a way contrary to these instructions. The Urn has resettable Boil Dry Protection.

FILLING THE PERCOLATOR

NOTE: *Read the Installation Instructions before proceeding. See the image in Percolator Parts section for reference.*

- Whilst filling the urn ensure power is off and the plug is disconnected from the power point.
- **IMPORTANT:** Be careful not to accidentally operate the Percolator without having water in the tank. *See Boil Dry Protection if this occurs.*
- Turn the lid of the percolator anti-clockwise to open and remove the coffee basket and percolator tube (if required).
- Fill the tank with water in situ, using a jug or a carefully handled water dispensing hose (if available). With the aid of the sight glass fill to desired cup capacity ensuring it is between 30 Cups and 60 Cup (“MAX”). The percolator will not brew properly if above or below these limits.
- **IMPORTANT:** The percolator is not designed to be carried or moved when full of water as the weight could cause injury or strain, and the handles may be damaged. The percolator should *not* be carried when more than ½ full, or if the water is dangerously hot.
- Push the percolator tube into the filter basket hole (if required).
- Insert the joined basket & tube into the tank ensuring the flare at the base of tube sits into the hole at the bottom of the tank. The top of the basket should sit approximately 2-3 cm below the rim of the tank.

-
- Fill the coffee basket with decent ground coffee ensuring that the coffee is spread evenly across. *See Coffee Measurement Table for quantity of coffee.*

OPERATION

- Ensure the mains power is now connected. Press the power switch to the “On” position. Initially the Red “Percolating” pilot light illuminate.
- Eventually a cyclic gurgling noise will indicate that the process of percolation is occurring. Steam will squirt hot water upwards through the percolation tube and out over the coffee basket, draining thru the coffee back into the water below.
- **NOTE:** The Lid should not be opened during Percolation. As a safety measure exclusive to Robatherm, a patented safety dome will protect any people from being splashed with boiling water if the Lid is inadvertently opened during operation.
- Eventually the water will reach approximately 88°C and the percolation will stop. The “Ready” light will activate indicating the coffee is ready to serve.
- **NOTE:** The coffee will be kept warm whilst the “Ready” light is on. No manual temperature control is required for this Robatherm Percolator.
- **NOTE:** The boiling point of water decreases at high altitudes. At altitudes higher than 2500m this machine will percolate continuously and should not be used.
- Position a cup with appropriate heat resistance and insulation under the tap and carefully press the lever to dispense coffee to the desired level.
- When the coffee gets so low that it is impossible to dispense from the tap the percolator should be turned off for refilling or cleaning. *See next sections.*
- **IMPORTANT:** Do not leave the percolator operating unattended for long periods. Regularly check the water level to ensure the urn does not boil dry.

REFILLING THE PERCOLATOR

If more coffee is required then the Urn needs to be emptied of old coffee before refilling.

- **IMPORTANT:** For safety ensure the machine is unplugged before refilling.
- Open the lid carefully as it may be hot.
- Carefully pour about a litre of cold water over the basket and safety dome to hasten cooling.
- Once cool, carefully hold the safety dome and lift out the coffee basket & tube.
- Dispose the old coffee granules into a bin and rinse the basket in the sink.
- Carefully tip the percolator over a sink to pour out the small quantity of coffee dregs still remaining in the tank. Rinse the tank if desired. Do not immerse the percolator or pour water on the outside of the tank.
- Refill the percolator with coffee and water - *See Filling the Percolator*

BOIL DRY PROTECTION

If ever the Percolator is left operating unattended for long periods it will boil dry. A boil dry thermal cutout will automatically turn off the heating elements to stop the machine overheating. The “Percolating” and “Ready” Lights will also turn off. To reset after a boil dry situation:

- **IMPORTANT:** Do not intentionally boil dry as it will significantly shorten the life of components, and unnecessarily waste energy.
- Should a boil dry occur, turn the Percolator off and unplug from the power point.
- Allow the percolator to cool down completely.
- Remove the lid and the coffee basket/tube.
- Carefully tilt the urn over a small amount and feel under the base for the reset button.
- Press the button to reset the percolator. You may here a small click if the room is quiet.
- The percolator is now ready for refilling, or cleaning.

PERCOLATOR DIAGRAM

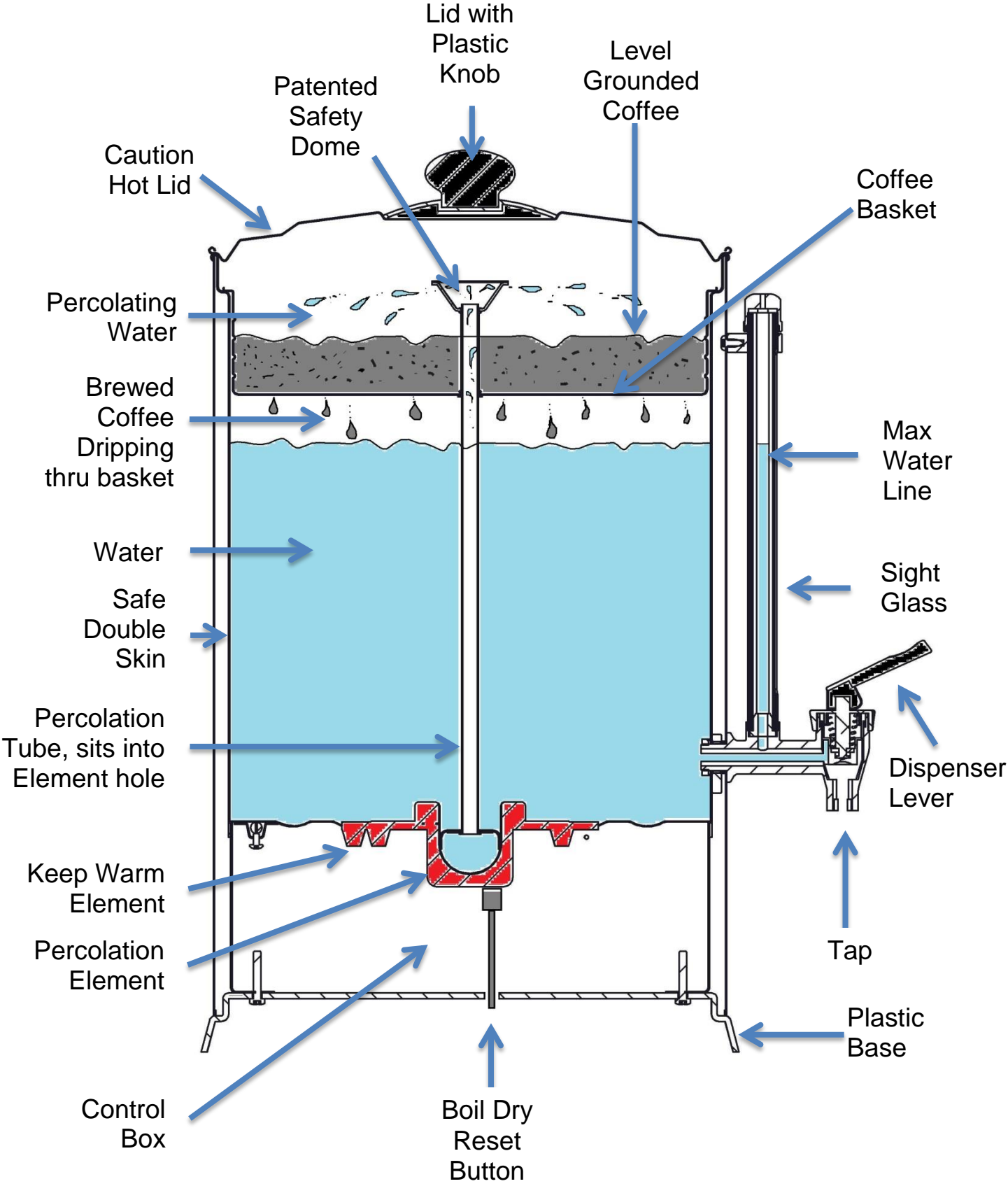

COFFEE MEASUREMENT TABLE

See the table below to determine the amount of ground coffee to add the basket. This table should be used as a guide only. It should make a medium strength coffee. The amount of coffee used can be adjusted to personal taste.

IMPORTANT: Fill the water level to between 30 and 60 cups only. Above or below these limits will affect the brewing process.

Cups Water (160mL per Cup)	Water (Litres)	Ground Coffee* (grams)	Basket Groove**	Percolation Time (approx.)
30 cups	4.8L	150g		15 mins
40 cups	6.4L	200g	2	20 mins
50 cups	8.0L	250g		25 mins
60 cups	9.6L	300g	3	30mins

* For medium strength coffee

** See grooves below

There are grooves on the side of the coffee basket which can be used for reference when filling the basket with ground coffee. Ensure the coffee is spread level. There is also MAX water mark stamped to the inner tank.

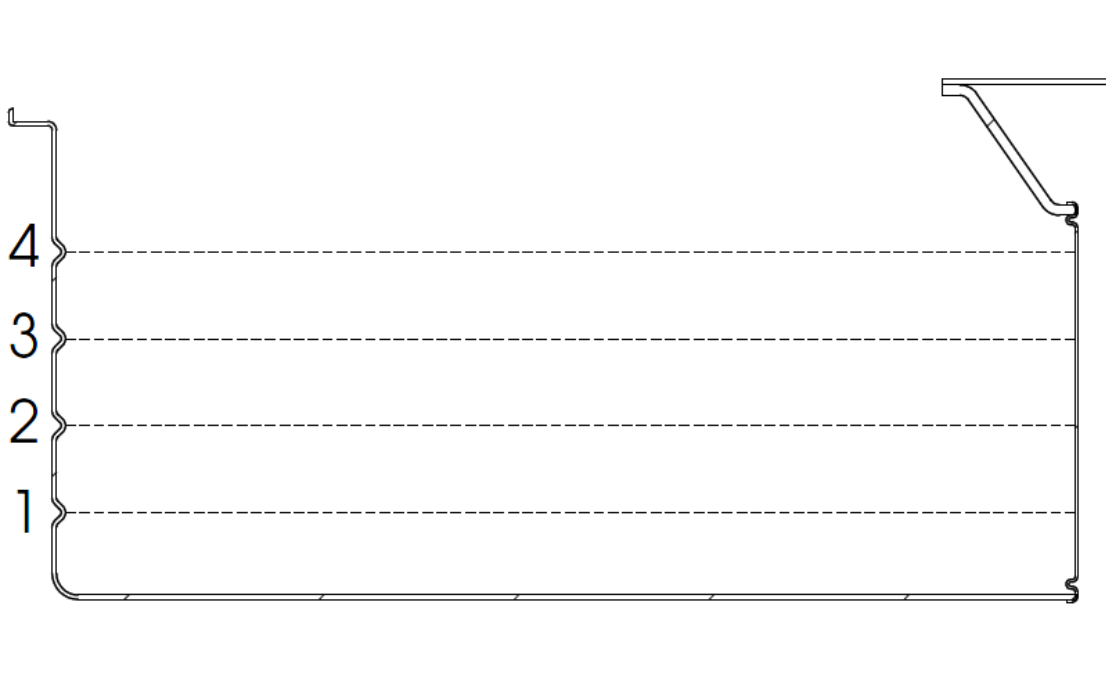

Coffee Basket Reference Grooves

CLEANING, CARE & MAINTENANCE

Attention to regular care and maintenance will ensure long and trouble free operation of your Percolator. The coffee percolator should be cleaned after every use.

- **IMPORTANT:** Before cleaning commences, ensure the coffee percolator is disconnected from power and has cooled down.
- Remove the Lid and, Lift out the Basket and Percolation Tube by holding the Safety Dome. Empty the used coffee in the bin. Disconnect the Percolation Tube by pulling it from under the basket.
- Carefully slide the percolator so that the tap is positioned over the side of the bench or table. Drain unused coffee into a jug and discard. The remaining coffee dregs can be tipped down the sink. **NOTE:** Be careful to ensure the Percolator is not too heavy to handle.
- Clean the basket, tube and lid with warm detergent and allow to dry.
- To clean the inside of the percolator use a non-metallic scourer and soapy water, rinsing well with clean water. Ensure the tap dispenser is rinsed well.
- Dry the inside of the percolator with a tea towel. **NOTE:** Do not leave sediments in the tank or else rusting could occur.
- The inside of the percolator should be checked regularly for any scale or other crusty deposits that may build up, which are caused by minerals in the water. Build-up of crusty deposits can be removed by filling the percolator with a solution of 1 part vinegar to 8 parts water and allowing it to soak overnight **without** turning the percolator on. After emptying, if any heat stains remain then rub some baking soda onto it whilst still wet, leave for 10 minutes and rub off. This should then be followed by the usual clean with soapy water and a very thorough rinsing. Ensure that the tap is flushed of any residue with clean water. **NOTE:** In areas where the water has a high mineral content then filtered water should be used to avoid rusting.
- Wipe down the outside of the machine with a cloth or sponge that is only damp with warm water. Add some detergent to the water if required. Take care to avoid water entering any part of the urn. Dry with a tea towel.
- Toxic cleaners should be avoided when cleaning the inside of the percolator as residual chemicals may remain inside if rinsing is inadequate. This residue may present a risk if mixed with drinking water and consumed. Caustic cleaners should **always** be avoided, as they may damage components inside and outside the unit.
- Although every care is taken during manufacture to remove all sharp edges, care should be taken when cleaning to avoid injury.
- This unit is not suitable for cleaning with the use of a water jet or immersion.

TROUBLESHOOTING

Only after all points below have been checked should you call for service:

If the Percolator is not working then:

- ✓ Check that the machine is plugged into the power point correctly and the power is switched on.
- ✓ Check that your power supply has not tripped a circuit breaker. The circuit breaker will trip for one or more of the following reasons:
 1. If you have connect too many high power appliances to the power circuit.
 - *Solution* – remove one or more high power appliance from the power circuit.
 2. If your circuit breaker includes RCD protection then it will trip if it detects too much electrical current leaking from the power circuit – this is a safety feature designed to protect against accidental electrocution. Note that it is normal for appliances with a heating element (like this percolator) to leak tiny amounts of current, particularly if it has not been used for a while. But if there is more than one heating element appliance connected to the power circuit then the total current leakage may exceed the RCD limit.
 - *Solution* – remove one or more heating element appliance from the power circuit. Contact your electrician if required.
 3. If an appliance is faulty
 - *Solution* – disconnect appliance and contact your service agent
 4. If there is an electrical issue with your wiring
 - *Solution* – contact your electrician
- ✓ Check that the Percolator is switched to the ON position. Either the Red or the Amber pilot light should be on.
- ✓ If both Pilot Lights are not on then the unit may have boiled dry and the thermal cutout may need resetting. *See Boil Dry Reset under Operation.*

If the Percolator boils continuously:

- ✓ Check your altitude above sea level. The percolator will boil continuously at high altitudes above 2500m. This is because the boiling point of water decreases as altitude increases. It is not possible to recalibrate the internal thermostat for high altitude use.

Note that if the machine has been used for any application contrary to what is described in this manual, all warranty is void.

SPECIFICATIONS

Model	CP60
Power Source	220-240 Volts AC / 50-60Hz
Power	1650 Watts
Tank Capacity	9.6 Litres
Capacity (160ml Cup)	60 Cups
Diameter	240 mm
Height	480 mm
Brewing Time (60 cups)	approx. 30 mins

Constant research and development may necessitate specification changes at any time.

CIRCUIT DIAGRAM

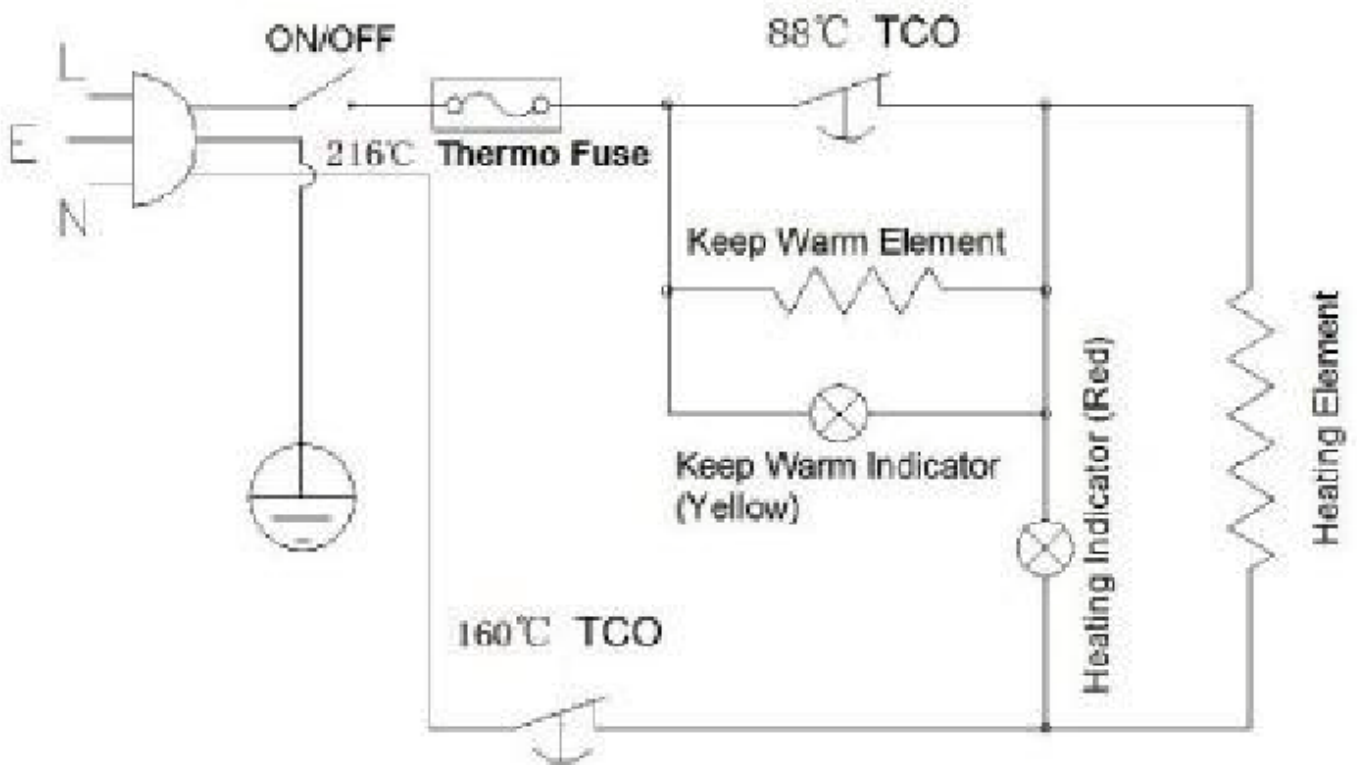

NOTE: This circuit diagram has been provided for reference and to assist qualified service technicians only. Under no circumstances should person's not suitably qualified attempt repairs to any electrical equipment.

SPARE PARTS LIST

Only qualified service technicians should open the control box, or replace any components, aside from loose items listed in the packaging section.

Part No:	Description:	Qty:
EC0239	Plug & Cord	1
EC0386	Pilot Light Amber	1
EC0407	Rocker Switch - On/Off (Including Silicone cover)	1
EC0442	Thermostat Cutout 160°C (includes Reset Button)	1
EC0443	Thermostat 88°C Fixed	1
EC0444	Pilot Light Red	1
MC0930	Tank Nut	1
MC0938	Sight Glass Knurled Nut	1
MC0983	Sight Glass Aluminium Body	1
MC0984	Coffee Basket	1
MC0985	Percolation Tube	1
MS0506	Tap Complete (includes tank nut and sea)	1
PC0415	Seal – for Tap Valve	1
PC0416	Seal – for Sight Glass Upper	1
PC0448	Seal – for Sight Glass Lower	1
PC0450	Seal – for Tank Nut	1
PC0460	Lid Knob Lower	1
PC0461	Lid Knob Upper	1
PC0484	Sight Glass	1
VC0041	Lid Complete (includes lid locks and knob)	1
VC0042	Side Handle Kit (Includes 2 side handles)	1

NOTES

EC DECLARATION OF CONFORMITY

Manufacturer	Roband Australia 1 Inman Rd Cromer NSW, 2099 Australia
Model Type	Robatherm Double Skin Urns
Description	Percolator
Date of first CE Marking	1 st January 2013
Specific Models	CP60 Includes export model: -UK, -F

STANDARDS:

This machine is designed in compliance with

- Machinery Directive 2006/42/EC
- Low Voltage Directive 2006/95/EC
- EMC Directive 89/336/EEC including amendments to 93/68/EEC
- WEEE Directive 2002/96/EC (WEEE)
- Restriction of Hazardous Substances in Electrical and Electronic Equipment 2002/95/EC (RoHS)
- EN60335.1 Household and similar Electrical Appliances
- EN60335-2-48 Commercial Electric Toasters and Grillers
- EN55014.2: 1997 Electromagnetic compatibility. Requirements for household appliances, electric tools and similar apparatus. Immunity.

ENVIRONMENTAL:

This product is designed in order to contribute as little as possible to the quantity and noxious nature of waste and risk of pollution or other environmental contamination.

Packaging materials used in this machine are designed to be recyclable.

DECLARATION

I hereby declare under our sole responsibility that the product mentioned above to which this declaration relates complies with the above-mentioned standard(s).

Signature of Authorised Person:  Date: 1st January 2013
Print Name: Mal Johnston Position: Director of Engineering

WARRANTY

Every care is taken to ensure that no defective equipment leaves our factory and all goods manufactured by us are guaranteed against defective workmanship and materials for a period of 12 months from the date of purchase. Roband Australia's obligations pursuant to this express warranty being limited to the repair or replacement of the defective goods or materials, at its option and subject to the terms contained within this Warranty statement. Where relevant, glass, Teflon® and lamps are **not** included in this warranty and RCD tripping due to moisture absorption by Tubular Heating Elements is not considered a warranty fault.

Generally, all goods claimed under this warranty must be returned to the factory or an authorized service agent, freight prepaid, for inspection. All parts deemed to be defective will be replaced, however, no claims will be entertained for second hand products, or parts damaged in transport, misused or modified in any way without our approval. For machines that are not considered to be portable (e.g. food bars, rotisseries, large hotplates and some bain maries), on site warranty service will be provided in capital city metropolitan areas only. In all other locations, the customer is responsible for all travelling time/service call costs and payment for this will be required prior to the commencement of the repair. The labour costs to actually repair the fault will be met by the company.

Any repairs or replacement of defective goods or materials pursuant to this warranty, must be authorized by Roband Australia prior to any action being taken. The company reserves the right to reject a claim for warranty if it is not completely satisfied with the circumstances under which it occurred and any other costs incurred for false claims or faults due to incorrect usage etc. are the responsibility of the claimant. Roband Australia Pty Ltd nor any subsidiary company or Agent shall be liable for loss of profit or damage to other equipment and property except where it is in breach of the guarantees provided in accordance with Schedule 2 of the Competition and Consumer Act 2010 (Cth) or the applicable legislation from time to time.

The goods come with guarantees that cannot be excluded under the Australian Consumer Law (ACL). You are entitled to a replacement or refund for a major failure and for compensation for any other reasonably foreseeable loss or damage. You are also entitled to have the goods repaired or replaced if they fail to be of acceptable quality and the failure does not constitute a major failure.

Generally, authorized service agents are located in all areas which have authorized distribution dealers. For the name of your nearest Australian authorised service agent, please contact:

Roband Australia Pty Ltd

1 Inman Road, Cromer, NSW 2099

Warranty Number: 1800 268 848

Phone: (02) 9971 1788 Fax: (02) 9971 1336

All other countries please contact your selling Agent.

Please complete the following details and keep this card in a safe place.

NAME _____

ADDRESS _____

MODEL No: _____ SERIAL No: _____ DATE PURCHASE _____

NAME OF DEALER: _____

PLEASE RETAIN THIS SECTION FOR YOUR RECORDS

DO NOT POST

ROBAND® AUSTRALIA PTY LTD

OTHER LEADING PRODUCTS AVAILABLE:

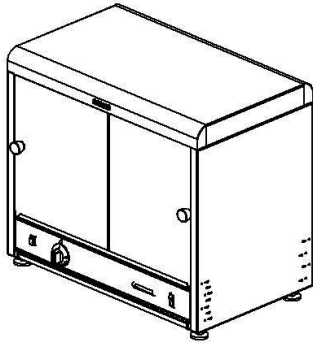

π-PLUS
PIE & FOOD WARMERS



DRINK MIXERS

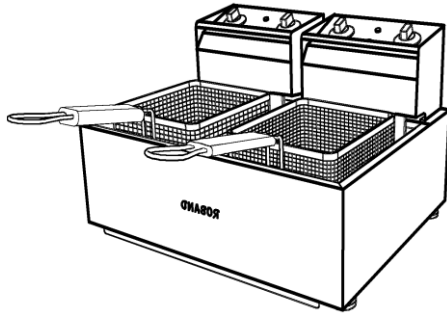

HIGH PERFORMANCE DEEP FRYERS

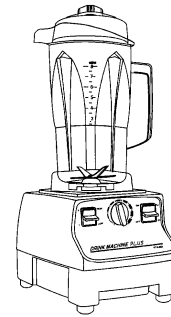

VITAMIX BLENDERS

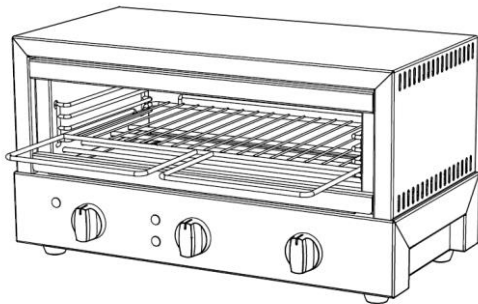

GRILLMAX TOASTERS

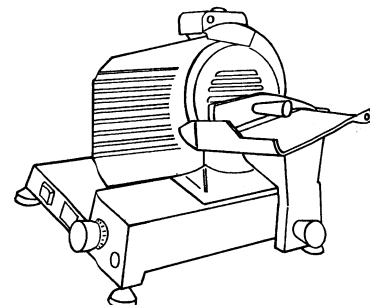

NOAW Slicers

Manufactured/Imported in Australia by:

ROBAND
AUSTRALIA PTY LTD

Authorised Distributor/Agent