

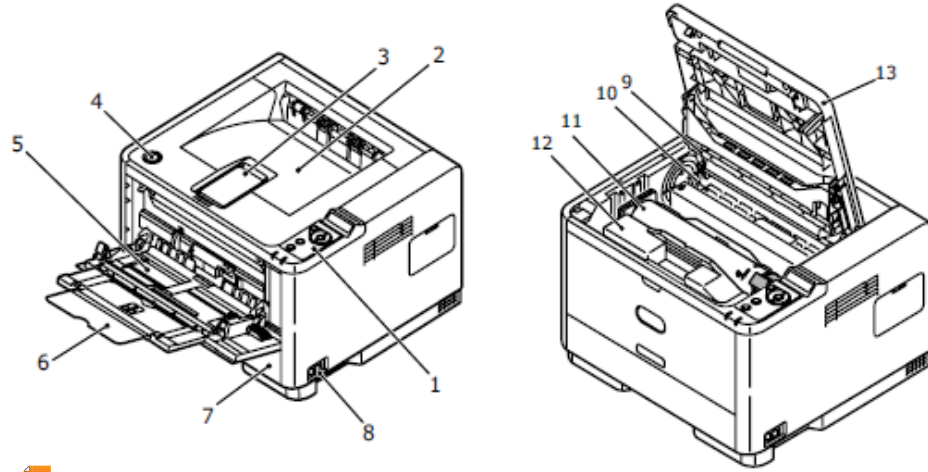

e-STUDIO382P Operating Instructions

TOSHIBA
Leading Innovation >>>

Printer Components



- 1 Operator Panel
- 2 Output Stacker (150 sheets, face down)
- 3 Output Stacker extension
- 4 Top cover release button
- 5 Multi Purpose Tray (100 sheets, shown in open position)
- 6 Multi Purpose Tray extension
- 7 Paper Tray (250 sheets)
- 8 ON/OFF switch
- 9 LED array
- 10 Fuser Unit
- 11 Toner cartridge
- 12 Image drum
- 13 Top cover

Paper Recommendations

Paper and Envelope Types

- Use a smooth finished paper such as copier or laser type paper with a Sheffield (smoothness) rating of 250 or less.
- Use paper and envelopes that are designed for use in laser type printers.
- The use of heavily laid or textured paper will seriously impact the life of the image drum.
- Do not use very smooth, shiny/glossy and embossed headed paper.
- Do not use specially treated papers such as carbon paper, non-carbon paper, thermal paper and impact paper.
- Avoid using paper with perforations, cut-outs and ragged edges.
- Do not use envelopes with windows or metal clasps.
- Do not use envelopes with self sealing flaps.
- Avoid using damaged or curled envelopes.

Transparencies and Adhesive Labels

- Always manually feed single sheets using a Manual Feed Tray or Multi Purpose Tray.
- Always use rear output.
- Media must be designed for use in laser printers or photocopiers and must be able to withstand 200C for 0.1sec.
- Do not use media designed for use in colour laser printers and photocopiers.

Multi Purpose Tray and Manual Feed Tray

- 1 Pull down the Multi Purpose Tray (1)
- 2 Extend the tray (2)
- 3 Fold out the paper supports (3)
- 4 Adjust the paper guides to the width of the paper (4).
- 5 Load the paper into the Multi Purpose Tray and push the Set button (5). Ensure that the paper is loaded below the arrow level (6) to avoid paper jam.

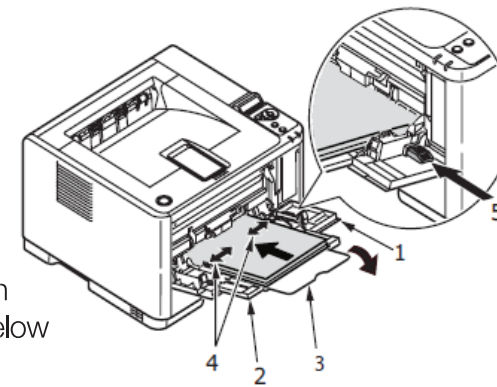

e-STUDIO382P

- For single-sided printing on headed paper load the paper with the pre-printed side up and top edge into the printer.
- For two-sided (duplex) printing on headed paper, load the paper with the pre-printed side down and top edge away from the printer.
- Envelopes should be loaded flap down, face up with the top edge to the left and short edge into the printer.

Duplex

- Automatic two-sided printing on the same range of paper sizes as tray 2 (i.e. all cassette sizes except A6), using paper stocks from 64-176g/m2.

Face Down Stacker

- Make sure the Rear Stacker is closed (the paper exits from the top of the printer).
- The Output Stacker on the top of the printer stacks printed pages face down, capacity of 150 sheets of weight 80g/m2.
- Pages printed in reading order (page 1 first) will be sorted in reading order (last page on top, facing down).

Face Up Stacker

- The face up stacker at the rear of the printer should be opened and the tray extension pulled out when required for use. (With the face up stacker either opened or closed, the driver setting of face down will successfully direct prints to the face down stacker).
- Can hold up to 100 sheets of 80g/m2 standard paper.
- Always use this stacker and the multi-purpose feeder for stocks heavier than 176g/m2, to reduce the possibility of paper jams.

Replacing Consumable Items

Only use genuine original consumables to ensure the best quality and performance from your hardware. Non original products may adversely affect your printer's performance and invalidate your warranty.

Toner Cartridge Replacement

NOTE: When the LCD display indicates TONER LOW, or if print appears faded, first open the top cover and try tapping the cartridge a few times to evenly distribute the toner powder. This will enable you to obtain the best "yield" from your toner cartridge.

To avoid toner wastage and possible toner sensor errors, do not change the toner cartridge(s) until "TONER EMPTY" is displayed.

The toner used in this printer is a very fine powder. It is contained in four cartridges: one each for cyan, magenta, yellow and black.

Dispose of the old cartridge responsibly inside the recycle bag that came with the new cartridge. Follow any regulations, recommendations, etc., which may be in force concerning waste recycling.

If you do spill any toner powder, lightly brush it off. If this is not enough, use a cool, damp cloth to remove residue. Do not use hot water or any solvents as they make toner powder stains permanent.

For Toshiba Service and Supplies call:

1300 887 600