



Operating Instructions
AirLite[®] Sample Pump
Catalog No. 110-100

SKC Inc.
863 Valley View Road
Eighty Four, PA 15330

Form #37814 Rev 0802

Table of Contents

AirLite Quick Start Guide	1
Description	3
Performance Profile	4
Pump Run Time (Table 1)	5
Operation	
Changing the Batteries	6
Setting the Flow Rate for High Flow Sampling	7
Setting the Flow Rate for Low Flow Sampling	8
Sampling.....	10
Reading the LED	10
Flow Fault Detection.....	11
Disabling Fault Indicator and Auto Restart Feature.....	11
Replacement Parts	12
Optional Accessories	13
Service Policy	14
Warranty	15



Indicates a warning or caution.



Indicates a note or reminder.



Indicates a premiere feature of the pump

Notice: This operating instruction may not address all safety concerns (if any) associated with this product and its use. The user is responsible for determining and following the appropriate safety and health practices and regulatory limitations (if any) before using the product. The information contained in this document should not be construed as legal advice, opinion, or as a final authority on legal or regulatory procedures.

AirLite Quick Start Guide

On/Off

1. Lift control cover on top of pump.
2. Press on/off button.

Setting Flow Rate (1000 to 3000 ml/min)

1. Set up sampling train.
2. Connect calibrator to inlet of sample medium.
3. Turn on pump and adjust flow adjustment screw on pump until desired flow rate is indicated on calibrator. Take a minimum of three readings. Calculate flow as the average of three readings.

LED Indicators

Slow flash = normal run

Fast flash = flow fault

Double flash = low battery, approximate minimum one-hour run time remaining

Flash every eight seconds = pump shutdown due to exhausted batteries

Four flashes every six seconds = pump shutdown due to flow fault



Note: Indication of pump shutdown due to exhausted batteries will override all other indicators.

AirLite uses three replaceable standard AA alkaline batteries.

Description

The AirLite® Personal Sampling Pump is specifically designed for personal sampling of asbestos, lead, and other airborne contaminants in environments where intrinsic safety is not required. Powered by economical, disposable AA alkaline batteries, the AirLite provides run times greater than 8 hours in the 1000 to 3000 ml/min flow range with full back pressure compensation.

Features:

- Economical alkaline battery operation
- Built-in pulsation dampener
- Built-in replaceable particulate trap
- Easy access battery compartment
- Impact-resistant RFI-shielded case
- User option auto restart from flow fault
- One-year limited warranty
- Economical alkaline battery operation
- LED indicates pump running, flow fault, and low battery

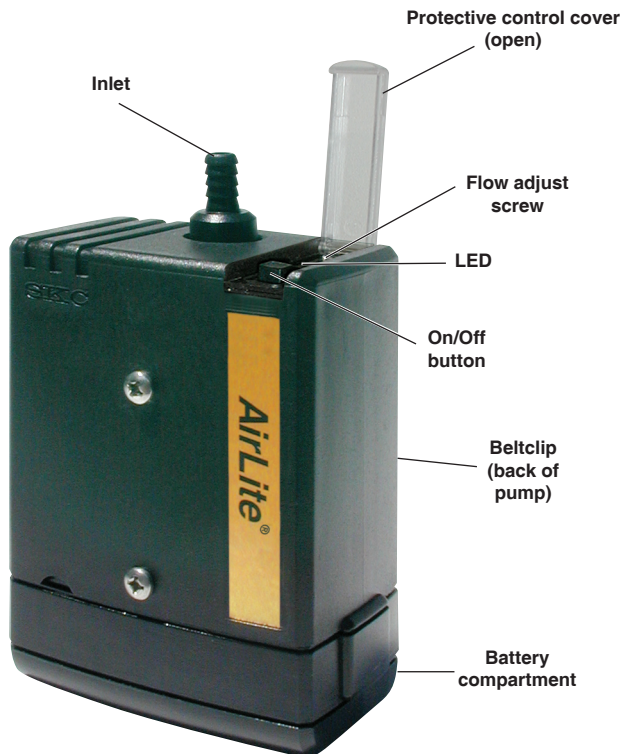

Front View

Performance Profile

Flow Range: 1000 to 3000 ml/min
 (5 to 500 ml/min requires Constant Pressure Controller (CPC) and Adjustable Low Flow Tube Holder - *see Low Flow Adapter Kit in Optional Accessories*)

Flow Control: Patented* system holds constant flow to $\pm 5\%$ of the set-point

Compensation Range 1000 ml/min at 30 inches water back pressure
for a Minimum of 2000 ml/min at 20 inches water back pressure
8-Hour Operation: 3000 ml/min at 10 inches water back pressure

Typical Back Pressure of Sampling Media (*inches water*)

Flow Rate (L/min)	1.0	1.5	2.0	2.5	3.0
Filter/Pore Size (μm)					
25-mm MCE/0.8	6	9	12	15	—
25-mm MCE/0.45	14	22	—	—	—
37-mm MCE/0.8	2	3	4	5	6
37-mm PVC/5.0	1	1	2	2	2.5

Compare the information in this table to pump compensation range to determine appropriate applications.

Temperature Range: **Operating:** 32 to 113 F (0 to 45 C)
Charging: 32 to 113 F (0 to 45 C)
Storage: -4 to 113 F (-20 to 45 C)



Caution: Protect sample pump from weather when in use outdoors.

Compensated Temp. Range: ...41 to 122 F (5 to 50 C)

Power: Three standard AA alkaline batteries
Rechargeable AA size 1.2-volt NiMH batteries may be used, but will provide approximately half the run time stated for disposable batteries.

Case: Plastic, RFI/EMI-shielded, CE marked

LED Functions: **Slow flash** = normal run
Fast flash = flow fault
Double flash = low battery, approximately one-hour run time remaining
Flash every eight seconds = pump shutdown due to exhausted batteries†
Four flashes every six seconds = pump shutdown due to flow fault

Battery run time: Dependent on batteries used. *See Table 1.*

Dimensions: 4.6 x 3 x 1.75 inches (11.7 x 7.6 x 4.4 cm)

Weight (including batteries): 12 oz (340 gm)

* U.S. Patent No. 6,741,056 † Indication of pump shutdown due to exhausted batteries will override all other indicators.



Caution: Do not operate AirLite in hazardous or explosive locations. AirLite is designed for applications that do not require intrinsic safety.

Table 1. Pump Run Time in Hours with Alkaline Batteries

Following are typical run times achieved when using new disposable AA alkaline batteries. Data is sorted by type of sample media. All run times are listed in hours.

Mixed Cellulose (MCE) Filter, 0.8- μ m pore size

Filter Diameter	37 mm	37 mm	37 mm	25 mm	25 mm
Flow Rate	1 L/min	2 L/min	2.5 L/min	1 L/min	2 L/min
Duracel Standard	23.5	14.5	13.5	18.5	10.5
Rayovac Maximum	20.0	16.5	14.0	16.5	11.0
Wal-Mart EverActive	24.0	16.0	10.5	18.0	10.5
Eveready Alkaline	20.0	14.0	13.0	17.0	Not tested

Polyvinyl Chloride (PVC) Filter, 0.8- μ m pore size

Filter Diameter	37 mm	37 mm	37 mm	25 mm	25 mm
Flow Rate	1 L/min	2 L/min	2.5 L/min	1 L/min	2 L/min
Duracel Standard	23.5	15.5	17.0	23.0	10.5
Rayovac Maximum	29.5	16.5	14.0	18.5	13.0
Wal-Mart EverActive	24.5	20.5	15.5	20.5	11.5

Glass Fiber Filter

Filter Diameter	37 mm	37 mm	37 mm	37 mm
Flow Rate	1 L/min	2 L/min	2.5 L/min	3 L/min
Energizer	29.5	18.0	21.0	18.5
Rayovac Maximum	26.5	23.5	23.0	14.0
Wal-Mart EverActive	33.5	24.5	17.5	19.0
Filter Diameter	25 mm	25 mm	25 mm	25 mm
Flow Rate	1 L/min	2 L/min	2.5 L/min	3 L/min
Energizer	29.0	18.5	18.5	12.0
Rayovac Maximum	9.5	19.5	14.5	13.5
Wal-Mart EverActive	26.0	20.0	14.5	14.0



Caution: To prevent corrosion of battery terminals, remove batteries when AirLite will not be used for an extended time.



Note: Increases in back pressure in sampling condition due to buildup on filter can decrease battery life.



Note: For maximum run time, insert new batteries in pump before sampling.



Note: If using rechargeable AA 1.2-volt NiMH batteries, run time will be approximately half that stated for disposable batteries.

Operation

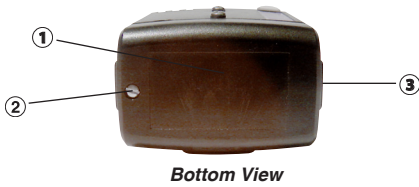

Bottom View

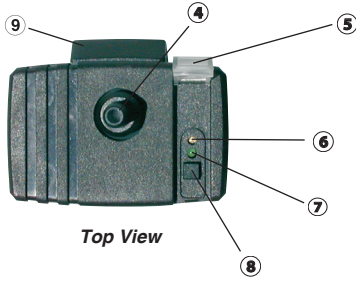

Top View

- 1 Battery Compartment Door
- 2 Battery Compartment Screw
- 3 Hinge
- 4 Inlet
- 5 Control Cover (open)
- 6 Flow Adjustment Screw
- 7 LED
- 8 On/Off Button
- 9 Belt Clip (back of pump)

Figure 1

Top and bottom views

Changing the Batteries

The AirLite is powered by three standard AA alkaline batteries located in a compartment on the bottom of the pump (Figure 1, #1).

To change the batteries, use a slotted screwdriver to loosen the screw on the bottom of the case (Figure 1, #2). Open and remove the compartment door. Remove the existing batteries and replace with new batteries (*see battery polarity below*). Once the new batteries are in place, insert the hinge (Figure 1, #3) on the compartment door under the lip of the case, close the door, and tighten the screw until secure.

1



Polarity of Batteries



Important: Note the polarity of the batteries.



Note: For maximum run time, insert new batteries in pump before sampling. If using rechargeable AA 1.2-volt NiMH batteries, expect approximately half the run time stated for disposable batteries.



Note: To prevent corrosion of battery terminals, remove batteries when AirLite will not be used for an extended time.

2

Setting or Verifying the Flow Rate

For High Flow Sampling (1000 to 3000 ml/min)

Using 1/4-inch ID tubing, connect a representative sampling medium to the pump inlet (Figure 1, #4). Connect an external flowmeter to the inlet of the sampling medium.

Turn on the pump using the on/off button (Figure 1, #8). To adjust the flow, turn the flow adjustment screw (Figure 1, #6) clockwise to increase the flow or counterclockwise to decrease the flow until the desired flow rate is indicated on the flowmeter. When the desired flow is obtained, take three readings to confirm that the flow rate is consistent. Calculate and record the flow rate as the average of three readings.

Disconnect the flowmeter and replace the representative sampling medium with a new unexposed medium for sample collection.

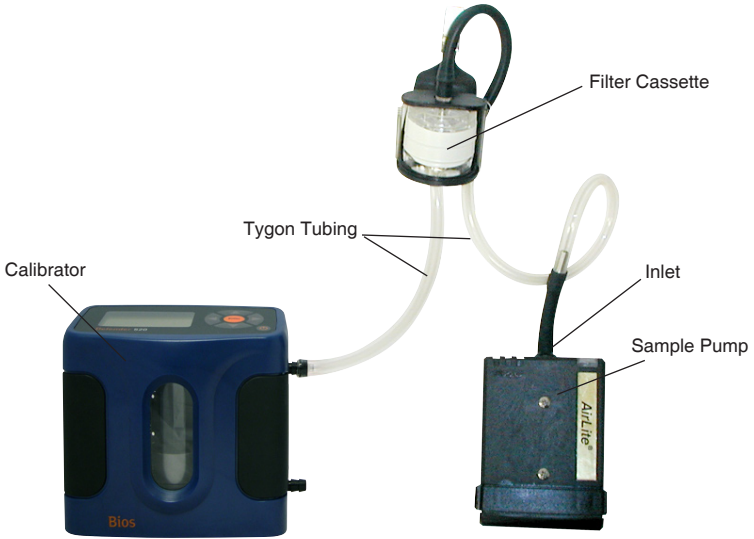

Calibration train with filter cassette

continued on page 8

Setting or Verifying the Flow Rate For Low Flow Sampling (5 to 500 ml/min)

(Requires optional Constant Pressure Controller (CPC) and Adjustable Low Flow Tube Holders - see Low Flow Adapter Kit in Optional Accessories.) See Figure 2.

The Constant Pressure Controller (CPC) accessory, Cat. No. 224-26CPC-10, is used as a pressure regulator to maintain a constant 10 inches water back pressure for low flow sampling. The CPC is used in conjunction with an Adjustable Low Flow Tube Holder (Cat. Nos. 224-26-01, -02, -03, or -04) for single or multiple-tube sampling.

Set the flow rate at approximately 1.5 L/min. (See *Setting Flow Rate for High Flow Sampling*, page 7.) For multiple-tube sampling, the flow rate must be greater than the sum of the required flow rates through all the tubes.

With a short length of Tygon® tubing, connect the pump inlet to the CPC outlet (the side of the CPC without a label), (Figure 2). Connect the inlet side of the CPC (marked "to sample") to the Adjustable Low Flow Tube Holder (Figure 2).

Label all tubes and ports. Insert opened representative tubes into the rubber sleeves of each port on the Adjustable Low Flow Tube Holder. If any port remains unused, place an unopened tube in it; it is important to "seal" unused ports.

Use tubing to connect the exposed end of one tube to a primary standard flowmeter. Loosen the screw on the low flow holder port. Turn on the pump using the on/off button (Figure 1, #8), and calibrate flow. Turn the brass screw (needle valve) on the Adjustable Low Flow Tube Holder (Figure 2) until the flowmeter matches the desired flow rate. For multiple-tube sampling, repeat this procedure for each port to calibrate the flow rate for each tube. Seal unused ports.

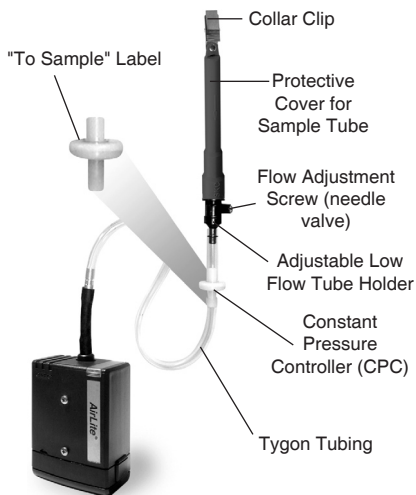

Figure 2
Configuration for Low Flow Sampling



Do not adjust the flow on the pump. Adjust flow by using the brass screw on the Adjustable Low Flow Tube Holder.

continued on page 9

2

cont'd

Turn off the pump. Disconnect the flowmeter and replace the representative tubes with new unexposed media for sampling.



Caution: Long-duration Color Detector Tubes require a special tube cover that accommodates an in-line trap tube. The trap tube protects the pump from caustic fumes that are often released from detector tubes. Please read closely all precautions when using these tubes.



Failure to use the necessary traps will damage the pump and void the warranty.



Caution: Do not operate AirLite in hazardous or explosive locations. AirLite is designed for applications that do not require intrinsic safety.



Note: The CPC has two small inlet ports on the bottom of the unit. These ports should be periodically inspected for blockage, which can occur when sampling in dusty environments. Blocked ports may cause back pressure to increase. Clean ports with a small pick and use air to blow away particles.

3

Sampling

Calibrate the sample pump for the desired flow rate (see *Setting or Verifying the Flow Rate*, pages 7 & 8). Attach the pump to a worker's belt and the sampling medium to the worker's collar (near the breathing zone). Turn on the pump. Record the start time and any other pertinent data. Monitor pump and battery status by observing the LED (see *Reading the LED* below). At the end of the sampling period, record the stop time. Cap the sample and send it with pertinent sampling information to a laboratory for analysis.



Clip sampling medium to worker and pump to belt.



Caution: Do not operate AirLite in hazardous or explosive locations. AirLite is designed for applications that do not require intrinsic safety.



Caution: Protect sample pump from weather when in use outdoors.

Reading the LED

The LED on top of the pump case (Figure 1, #7) indicates pump and battery status.

- Slow flash Normal run
- Fast flash Flow fault
- Double flash Low battery, approximately one-hour run time remaining
- Flash every eight seconds Pump shutdown due to exhausted batteries
- Four flashes every six seconds Pump shutdown due to flow fault



Note: Indication of pump shutdown due to exhausted batteries will override all other indicators.

continued on page 11

Flow Fault Detection

(Pumps are shipped with flow fault enabled.)

If the pump is unable to compensate for > 10 seconds due to excessive back pressure, the pump enters flow fault. The motor will stop and the LED will flash quickly. The auto-restart feature will attempt to restart the pump after 10 seconds. If back pressure is not corrected for an additional 10 seconds, the pump will attempt a second restart. The pump will continue restart attempts every 10 seconds for a total of five times. If restart attempts are unsuccessful, the pump will shutdown and the LED will flash four times every six seconds. If the excessive back pressure is removed within the five restart attempts, the pump will run normally.



Note: The pump must be running without fault for at least 20 seconds for the auto-restart feature to be reset to five tries.

Disabling the Fault Shutdown and Auto-restart Features

If the fault link is fitted when the pump is initially switched on, the LED will display a quick double flash before running. If the link is not fitted, the pump will immediately run without the LED flashing.

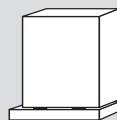

Link fitted

To disable the fault shutdown and auto-restart features, remove the two screws from the belt clip and set the clip and screws aside. Remove the single screw from the back of the pump case. Gently remove the top of the pump case by sliding it up and off. Using a pair of tweezers, grip and pull off the program connect link located on the board just below where the motor wires connect to the board. Reassemble the pump

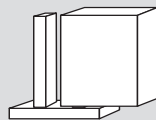

Link stored

and operate. The pump LED will indicate a flow fault by flashing quickly, but the pump will no longer shutdown during a flow fault. To restore flow fault shutdown and auto-restart features, replace the program connect link.

Tip: For easy storage of link, simply place the link on one pin only as shown above right.

Replacement Parts

No.	Description	Cat. No.
1	Stack screws	P51891
2	Inlet (hose connect)	P20106
3	Pulsation dampener	P2010802
4	Stack plate	N/A
5	Valve plates (top and bottom)	P213201
6	Diaphragm/Yoke assembly	P22417H
7	Pump body	P22417G
8	Motor/Eccentric	P51890
9	Pump base	P20182
	Battery case cover	P20184 (not shown)

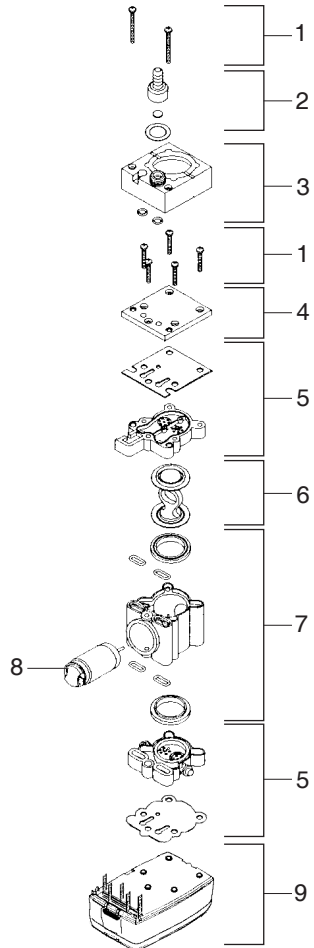

Optional Accessories

Calibrator:	Cat. No.
Defender Primary Standard Calibrator, 50 to 5000 ml/min, includes lead-acid battery, charger (100 to 240 V), Optimizer 110 Software, and 1-meter serial cable	717-510M
Low Flow Sampling Accessories:	Cat. No.
Low Flow Adapter Kit includes a Constant Pressure Controller (224-26CPC-10), Adjustable Low Flow Holder, and Type A Protective Tube Cover	110-500
Constant Pressure Controller <i>(included in Low Flow Adapter Kit above)</i>	224-26CPC-10
Single Adjustable Low Flow Tube Holder <i>(included in Low Flow Adapter Kit above)</i>	224-26-01
Dual Adjustable Low Flow Tube Holder	224-26-02
Tri Adjustable Low Flow Tube Holder	224-26-03
Quad Adjustable Low Flow Tube Holder	224-26-04
Protective Cover for Sorbent Tubes, Type A <i>(included in Low Flow Adapter Kit above)</i>	224-29A
Protective Cover for Sorbent Tubes, Type B	224-29B
Protective Cover for Sorbent Tubes, Type C	224-29C
Protective Cover for Sorbent Tubes, Type D	224-29D
Protective Cover for Sorbent Tubes, Type T	224-29T
Miscellaneous:	Cat. No.
Screwdriver Set <i>(included with pump)</i>	224-11
Protective Nylon Pouch with belt loop, black Waist Strap	224-902 224-12
Long-duration Detector Tube Sampling:	Cat. No.
Trap Tubes	222-3D-2
Tandem Protective Tube Cover	224-29T

Service Policy

To return products to SKC for servicing:

1. Call 800-752-8472 (724-941-9701 for international customers) to obtain a Return Materials Authorization (RMA) number and Product Decontamination Form.
2. Carefully package the product. Mark the RMA number on any correspondence relating to the return and on the outside of the package.
3. Ship to SKC, freight prepaid, to the following address:

SKC Inc.
National Service Center
863 Valley View Road
Eighty Four, PA 15330

Package product carefully to prevent damage during transit. Include a contact name, phone number, shipping address, RMA number, and a brief description of the problem. For nonwarranty repairs, a purchase order number and billing address are also required. The Service Department will contact nonwarranty customers with an estimate before proceeding with repairs.

Note: *SKC Inc. will accept for repair any SKC product that is not contaminated with hazardous materials. Products determined to be contaminated will be returned unserviced.*

SKC INC. LIMITED ONE YEAR WARRANTY

1. SKC warrants that its instruments provided for industrial hygiene, environmental, gas analysis, and safety and health applications are free from defects in workmanship and materials under normal and proper use in accordance with operating instructions provided with said instruments. The term of this warranty begins on the date the instrument is delivered to the buyer and continues for a period of one (1) year.

This warranty does not cover claims due to abuse, misuse, neglect, alteration, accident, or use in application for which the instrument was neither designed nor approved by SKC Inc. This warranty does not cover the buyer's failure to provide for normal maintenance, or improper selection or misapplication. This warranty shall further be void if changes or adjustments to the instrument are made by other than an employee of the seller, or if the operating instructions furnished at the time of installation are not complied with.

2. SKC Inc. hereby disclaims all warranties either expressed or implied, including any implied warranties of merchantability or fitness for a particular purpose, and neither assumes nor authorizes any other person to assume for it any liability in connection with the sale of these instruments. No description of the goods being sold has been made a part of the basis of the bargain or has created or amounted to an express warranty that the goods will conform to any such description. Buyer shall not be entitled to recover from SKC Inc. any consequential damages, damages to property, damages for loss of use, loss of time, loss of profits, loss of income, or other incidental damages. Nor shall buyer be entitled to recover from SKC Inc. any consequential damages resulting from defect of the instrument including, but not limited to, any recovery under section 402A of the Restatement, Second of Torts.

3. This warranty extends only to the original purchaser of the warranted instrument during the term of the warranty. The buyer may be required to present proof of purchase in the form of a paid receipt for the instrument.

4. This warranty covers the instrument purchased and each of its component parts.

5. In the event of a defect, malfunction, or other failure of the instrument not caused by any misuse or damage to the instrument while in possession of the buyer, SKC Inc. will remedy the failure or defect without charge to the buyer. The remedy will consist of service or replacement of the instrument. SKC Inc. may elect refund of the purchase price if unable to provide replacement and repair is not commercially practicable.

6. (a) To obtain performance of any obligation under this warranty, the buyer shall return the instrument, freight prepaid, to SKC Inc., at the following address:

SKC Inc., National Service Center
863 Valley View Road
Eighty Four, PA 15330 USA

(b) To obtain return authorization information or for further information on the warranty performance you may telephone 724-941-9701 at the above address. See Service Policy section in operating manual (if applicable).

7. This warranty shall be construed under the laws of the Commonwealth of Pennsylvania which shall be deemed to be the situs of the contract for purchase of SKC Inc. instruments.

8. No other warranty is given by SKC Inc. in conjunction with this sale.