

immerSUN[®]



Installation and User Guide



enaSOLAR

V4.0

Contents

Introducing the immerSUN	3
Main Screen	4
Savings	5
Boost (Manual)	6
Boost (Timed)	7
Menu	8
View Readings	10
Advanced Settings	12
External Boost Input	13
Multifunctional Relay	14
Installation	16
System Overview	18
immerLINK™ Linking Units	19
immerSUN at a Glance	20
Electrical Connections	22
Sensor Installation	23
Setup	24
EnaSolar Monitoring and Reporting	26
Configuring an EnaSolar Site	27
Wiring Diagrams	29
Wiring: Single Heater	30
Wiring: Two Heater	32
Wiring: Three Heater	34
Wiring: Underfloor Heating (opt. 1)	36
Wiring: Underfloor Heating (opt. 2)	38
Wiring: Dual Tariff (Single Meter)	40
Wiring: Dual Tariff (Two Meter)	42
Wiring: Pool or Heatpump	44
Error Messages	46
Technical Specifications	48
Site Installation Details	49
immerSUN Controller Details	50
Notes	51

For more information visit: www.enasolar.net for Technical Documents and Tutorial Videos.

Introducing the immerSUN™

Thank you for choosing immerSUN - You have made an excellent choice!

The immerSUN is a Solar PV Self-Consumption Controller for heaters. It tracks available surplus power from a grid-tied PV or Wind turbine system and varies the power to the heater to match the surplus power, therefore ensuring all of the green energy is fully utilised.

trusine™ Power Control Technology

The immerSUN uses TruSine™ power control technology. This means that the voltage is very smoothly adjusted to alter the power to the heater. The power going to the load is a non-distorted true sine wave, only the voltage is altered.

This control technology is unique to the immerSUN and is more sophisticated than any similar product on the market. TruSine™ technology ensures trouble free operation with all inverters and compatibility with all import/export energy monitors.

Feature Set

- Tracks surplus power and diverts this energy to the load
- trusine™ technology for fast and smooth automatic power adjustment
- Works with many microgeneration systems including PV, Wind and Hydro systems
- Clear graphical backlit LCD display
- Indicates current import/export power levels as well as diverted power to the heater
- Savings are accurately reported for the day, month, year as well as the total since installation
- Savings can be displayed in several currencies as well as kWhs
- No need to change immersion heater
- Works with many types of heater including storage, panel and underfloor
- One immerSUN can control up to 3 heaters sequentially
- Only one current sensor for ease of installation with the option of a wireless sensor
- Built-in 7-day programmable boost timer
- Manual boost function for both heater outputs
- Integral multi-function relay to provide additional functions such as: control, cylinder de-stratification pump control and export power threshold detect
- Up to 5 immerSUN's can be linked together for larger systems
- Smart, sturdy metal enclosure designed with the installer in-mind
- Fully short circuit protected in case of load fault
- Over load protection
- Soft starting to avoid power surges
- Smart meter compatible

Main Screen

The main screen shows the status of the immerSUN, the imported or exported power, the date and time and the savings made today.

The house in the centre of the screen will be 'happy' if no power is being imported, otherwise a straight face will be displayed. Arrows either side of the house show the direction of power.

From this screen the **Menu** can be accessed, a manual **Boost** can be triggered and there is a short-cut to the **Savings** data.

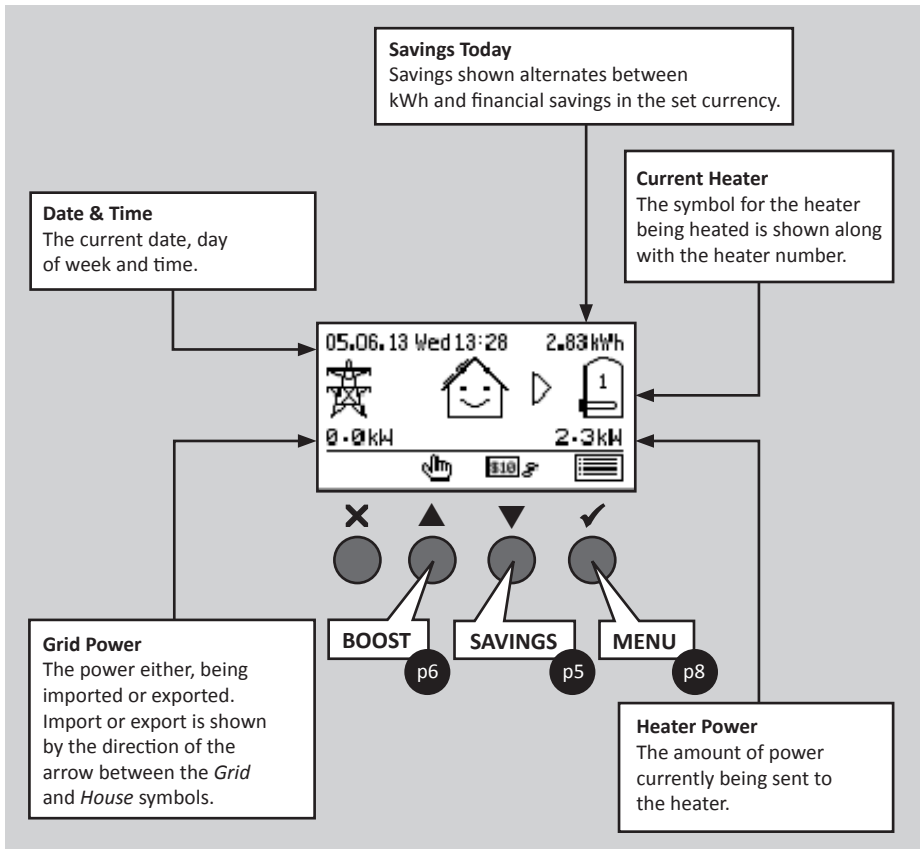

Savings

Savings that have been made by immerSUN are stored in permanent memory. The savings can be shown for Today, this Week, this Month and this Year as well as the Total since the immerSUN has been installed. The savings can be displayed as a list or in a graph.

The savings are shown in kWh as well as financially in the chosen currency. For the financial savings to be correct, the user must keep the tariff up to date. The **Set Tariff** option in the **Main Menu** allows the user to set the current tariff, this should be set to reflect the kWh cost for the fossil fuel normally used to heat the heater.

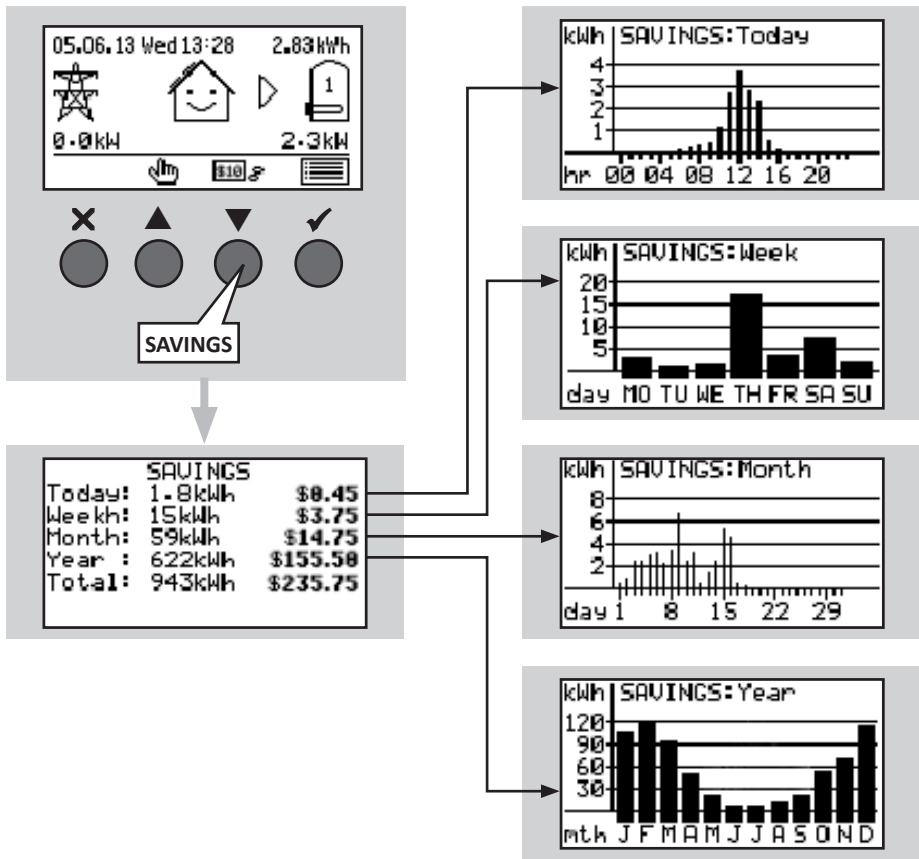

Boost (Manual)

A heater can be 'boosted' to full power for a short period regardless of the amount of available export power, this function is called **Manual Boost** and is activated from the main screen. Once the boost starts, the remaining boost period will be displayed, this will start at 1 hour but can be adjusted during the boost. A manual boost can be cancelled at anytime.

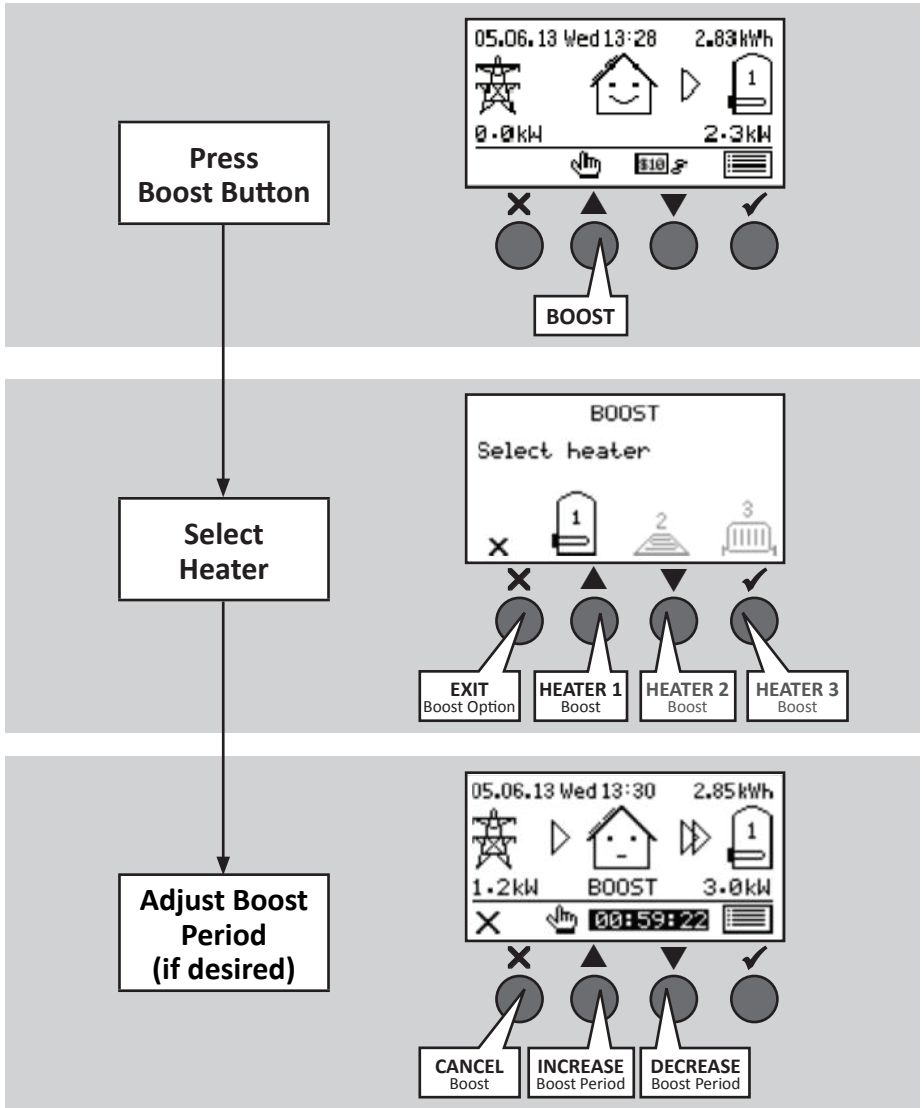

Boost (Timed)

The immerSUN can be programmed to ‘boost’ the heating for each heater at certain times. Boost means that the heater will be at full power regardless of the amount of available export power. This means that power may be drawn from the mains grid supply during boost times.

The **Boost Times** can be accessed from the **Main Menu**.

Once in the **BOOST TIMES** screen, use the ▲ and ▼ buttons to select the boost time you wish to change, then press ✓. You can now edit the boost times, use the ▲ and ▼ buttons to change the start time, end time, days of the week and heater number for the boost, (press the ✓ button to move to next section). Press the ✕ button to exit edit mode.

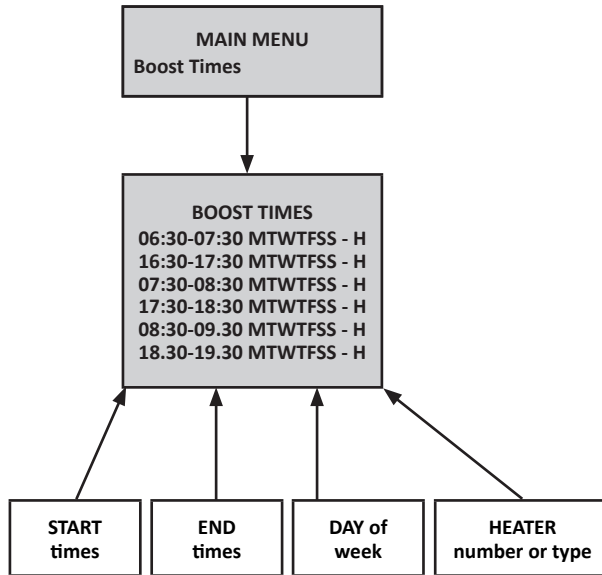

Special heater types

There are two special heater types; T and B. These will only be available if the Multi Function Relay is set to Export Threshold or Boiler Boost and wired correctly.

T: Export Threshold boost, the appliance will be activated for the boost period.

B: Boiler boost, the boiler will be activated for the boost period.

Important points

- Up to six different boost times can be entered.
- Each week day can be individually selected for each boost time.
- Only ONE heater can be boosted at any one time.
- If any boost times overlap, the latest timed boost will take precedence.
- For boost times crossing midnight, two time slots will need to be used.

Menu

The **Menu** is accessed by pressing the ✓ button from the main screen. Use the ▲ and ▼ buttons to select the required menu item, then press the ✓ button to select the menu option.

Press the ✕ button to exit or go back from a menu.

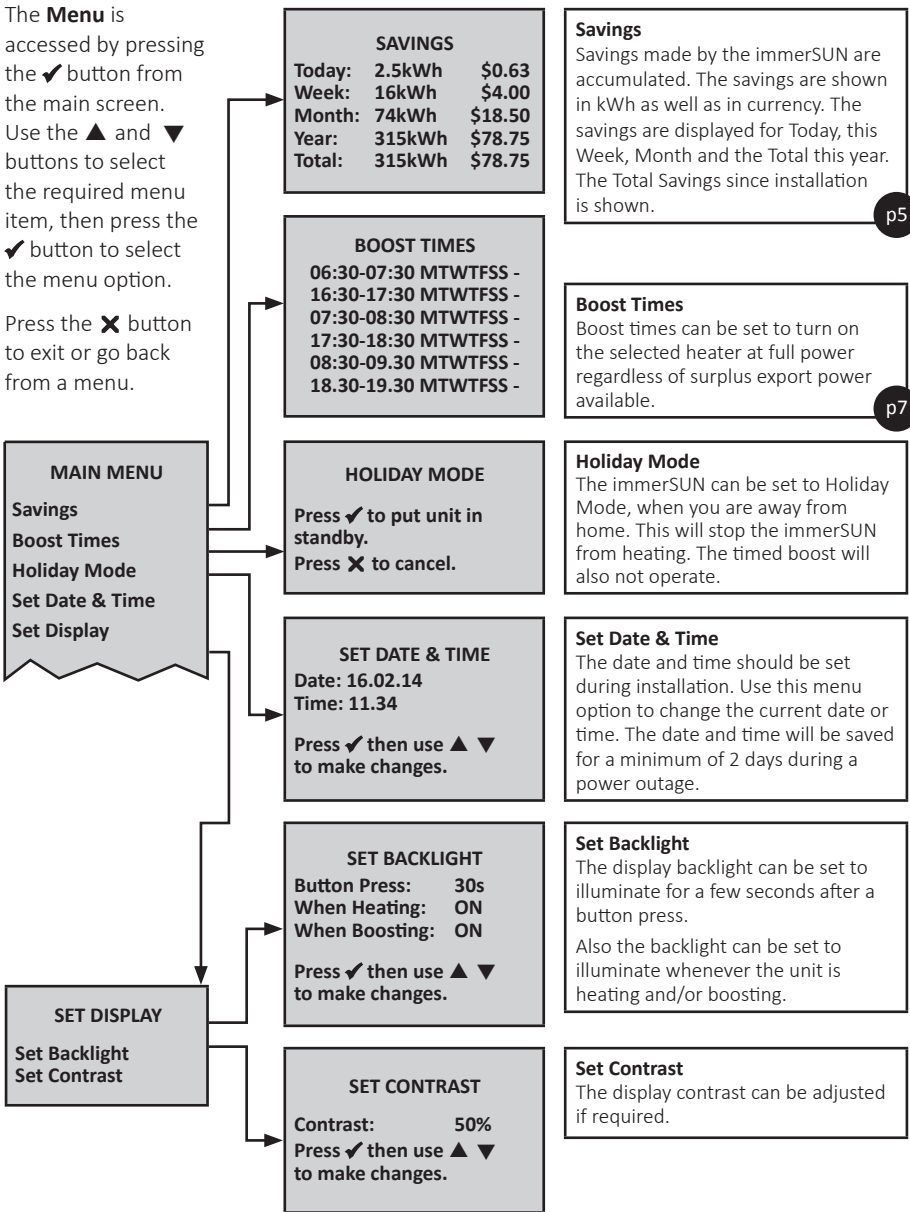

SET TARIFF
Current: \$000.25
New: \$000.25
From: 01/01/14
 Press ✓ then use ▲ ▼
 to make changes.

Set Tariff
 The tariff should be set to that shown on your utility bill. You will need to adjust the tariff from time to time as the tariff changes. The tariff should be for the fossil fuel you normally use to heat the appliance.
 The NEW tariff will take effect from the date entered, which can be a past or future date, meaning the NEW tariff does not need to be set on the day it changes.

Set Tariff:
Set Priority: 1-2
View Readings
View Configuration
Advanced Settings
Lock Advanced ✓

SET HEATER PRIORITY
Priority: 1-2-3
 Press ✓ then use ▲ ▼
 to make changes.

Set Heater Priority
 If two or three heaters are connected, the heating sequence can be selected.
 The higher priority heater will be heated until the thermostat opens, then the next priority heater will start to be heated and so on. When heating a lower priority heater, the unit will switch back to the higher priority heater periodically, this period is set by Priority Check Period in the Advanced Settings menu.
 If the heating priority is set to Equal, then each heater will be heated in-turn for the time set by the Priority Check Period in the Advanced Settings menu.

LOCK ADVANCED ✓

VIEW READINGS p10

Lock Advanced
 If ticked the Advanced Settings menu is locked, the passcode will need to be entered to access the menu.
 If the Advanced Settings menu is unlocked, the menu can be immediately locked by selecting this option.

VIEW CONFIGURATON
HEATER 1 TYPE
 Immersion (Top)
HEATER 2 TYPE
 Immersion (Bottom)
HEATER 3 TYPE
 Disabled
MINIMUM EXPORT: 50W
HEATER PRIORITY
 1-2
RELAY FUNCTION
 When heating
 1,2
 Include Boost
EXTERNAL BOOST
 Boost Heater
 1,2
SENSOR TYPE
 Wired
immerLINK™
 Unit: Master
 Slaves: 0
 Channel: 1
 Net ID: f428
 Gateway PW:3b5b4436

View Configuration
 This screen gives an overview of the immerSUN configuration.
 It is useful to check the current settings.

ADVANCED SETTINGS p12

View Readings

This screen shows various readings and other information. See the list below for a description of the readings.

This screen is useful for diagnosing installation issues.

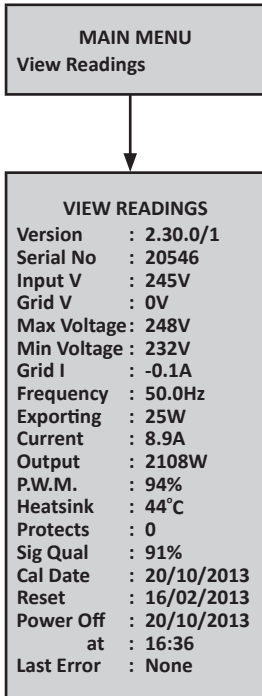

Title	Description
Version:	Firmware version number and hardware type
Serial No:	Serial number of the unit
Input V:	Supply input AC voltage
Grid V:	Voltage of the supply connected to the Wireless Sensor (where fitted), otherwise the same as Input V
Max Voltage:	Maximum supply voltage recorded since last switch on.
Min Voltage:	Minimum supply voltage recorded since last switch on.
Grid I:	Current seen by the sensor clamp
Frequency:	Supply frequency
Exporting/ Importing:	Power level currently being imported or exported
Current:	Input current of the unit
Output:	Power being delivered to the load
P.W.M.:	Output voltage percentage
Heatsink:	Temperature of the internal heatsink
Protects:	Count of over-current protections since switch on
Sig Qual:	Signal quality of the immerLINK™ wireless connection obtained between the immerSUN and the wireless CT clamp (if utilised), not the signal between the immerSUN unit and the Ethernet Bridge.
Cal Date:	Date the unit was calibrated at the factory
Reset:	Date the unit was factory reset
Power Off:	Last date and time power was lost to the unit
Last Error:	Last error number with date and time

Advanced Options...

Advanced Settings

Advanced Settings
Advanced Settings are accessed via the **Main Menu - Advanced Settings** Option

MAIN MENU
Advanced Settings

ADVANCED SETTINGS
Heater 1 Type
Heater 2 Type
Heater 3 Type
Minimum Export
Check Period
Relay Function
External Boost
immerLINK
Set Passcode
Locked Functions
Daylight Savings Time
Factory Reset

FACTORY RESET
Reset Config
Reset Savings
Reset Immerlink
Execute
Press **X** to cancel.

Factory Reset
To restore all settings to factory defaults, use this function. Reset Config and Reset Savings can be individually selected.

HEATER 1 TYPE
None
✓ Immersion T
Immersion B
Heater
Underfloor
Pool

MINIMUM EXPORT
Minimum Export: 50W
Press ✓ then use ▲ ▼ to make changes.

CHECK PERIOD
Period: 15 min
Press ✓ then use ▲ ▼ to make changes.

RELAY FUNCTION p14

EXTERNAL BOOST p13

IMMERLINK p19

SET PASSCODE
0 0 0 0

LOCKED FUNCTIONS
Set Date & Time
Boost Times
Manual Boost
Set Tariff
Set Priority

DAYLIGHT SAVINGS TIME
✓ Enabled
Last Sunday
March & October
Press **X** to exit.

Heater Type
The heater type can be set for each heater connected. Each heater type is represented by a different symbol on the main screen.

Minimum Export
This is the minimum level of export power, the default is 50W to ensure that the electricity meter does not register any import when the immerSUN is diverting energy.

Check Period
This is the time between checking to see if the priority heater(s) can accept more heat. e.g. Once the heater is at max temperature, the unit will switch to the next priority heater, however, it will switch back again after the set Period to check if there is a demand for heat from the higher priority heater.
Range = 0-60 min in 5 min steps.

Set Passcode
The passcode to access the Advanced Settings menu can be changed in this screen.

Locked Functions
Some functions can be hidden from the main menu to prevent accidental changes. Use this option to enable or disable these functions.

Daylight Savings Time
Enable or disable automatic clock adjustment for Daylight Savings Time (DST). When enabled the clock will be adjusted forward by one hour March and back one hour in October. Please Note: This is for the Northern Hemisphere.

External Boost Input

What Does It Do?

This is an external input which can be used to trigger a boost or enable/disable heater outputs.

The External Boost input is the 2-terminal connector labelled EX BST. Any AC voltage from 24V to 240V present on these terminals will be recognised by the immerSUN.

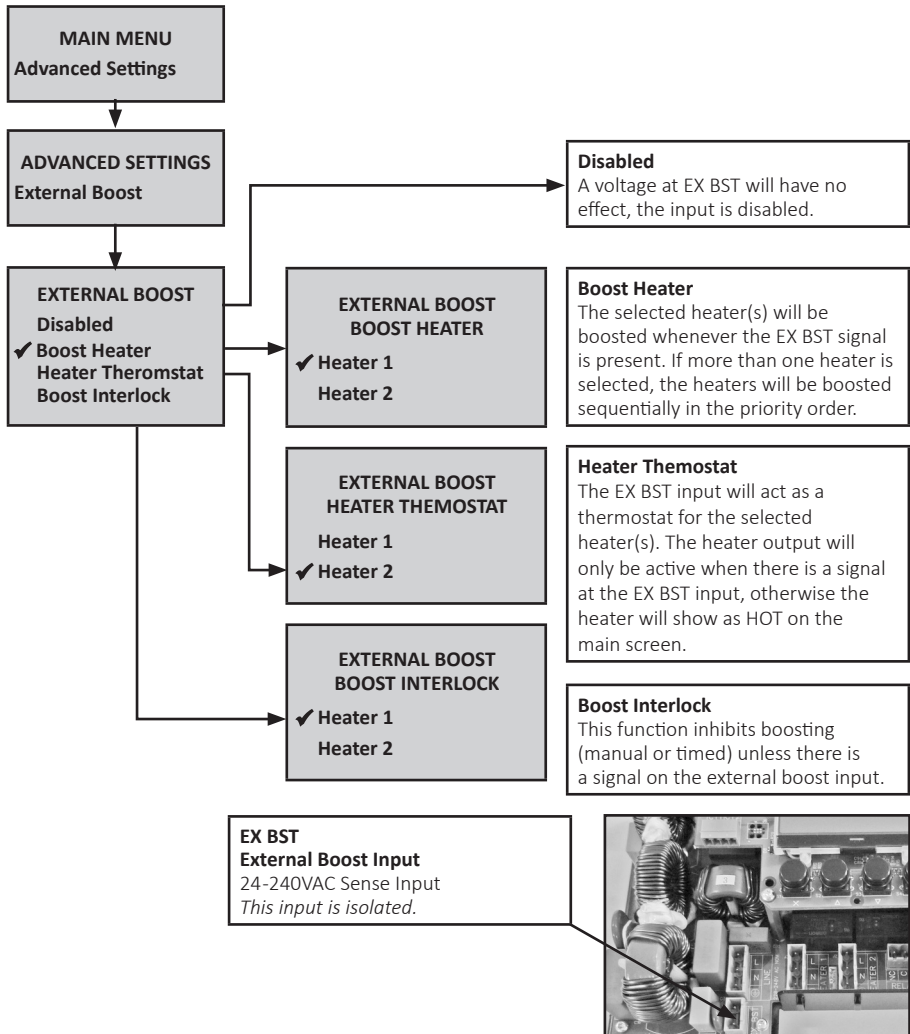

Multifunction Relay

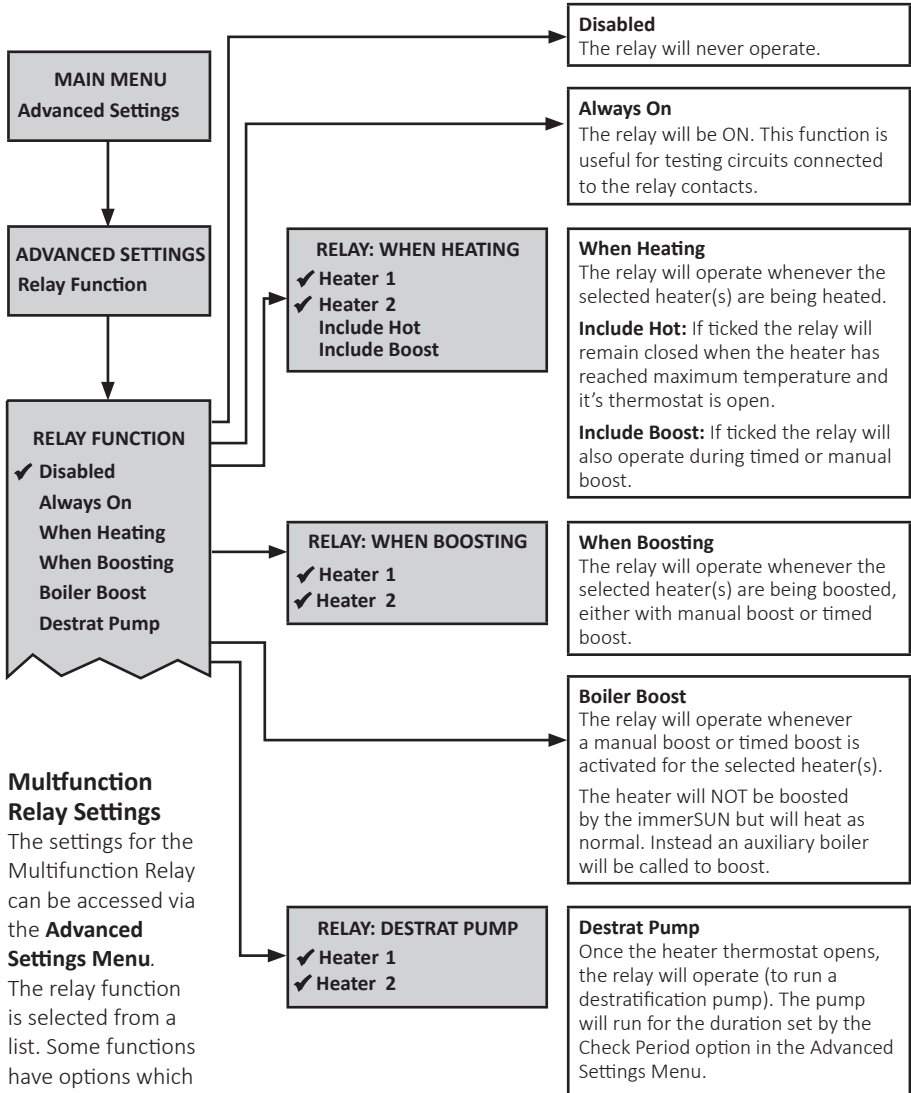

Multifunction Relay Settings

The settings for the Multifunction Relay can be accessed via the **Advanced Settings Menu**. The relay function is selected from a list. Some functions have options which can be defined.

What Does It Do?

The **Multifunction Relay** is a relay that can be used for many different purposes. The operation is controlled by the immerSUN and will operate when certain conditions are met, these conditions can be user defined. The relay can be used to control pumps, send signals to the boiler and switch on/off appliances etc.

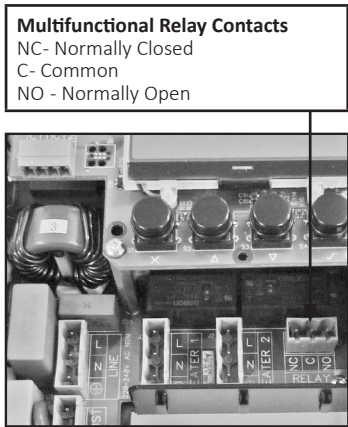
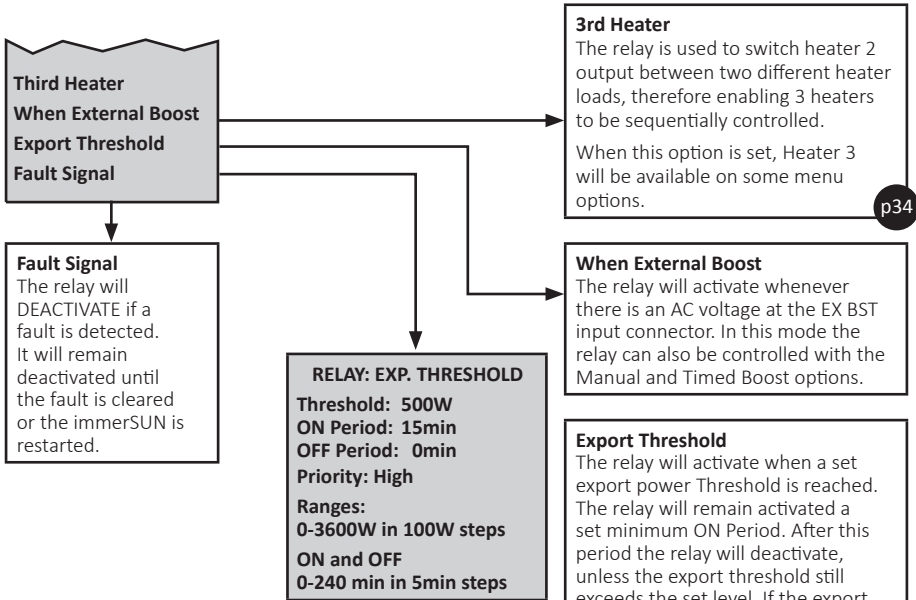

Export Threshold
The relay will activate when a set export power Threshold is reached. The relay will remain activated a set minimum ON Period. After this period the relay will deactivate, unless the export threshold still exceeds the set level. If the export has fallen below the threshold after the ON Period, the relay will immediately deactivate and will remain so for the set OFF Period. The ON Period needs to be >0 to be enabled.
This function operates independent to the heater outputs.
When the priority is set to HIGH the relay will activate when the surplus power exceeds the threshold set, i.e. it will include the already diverted power when waiting for the threshold to be exceeded. With the majority set to LOW, relay will activate when the exported power is greater than the set threshold.
In this mode the relay can also be controlled with the Manual and Timed Boost options.

Installation

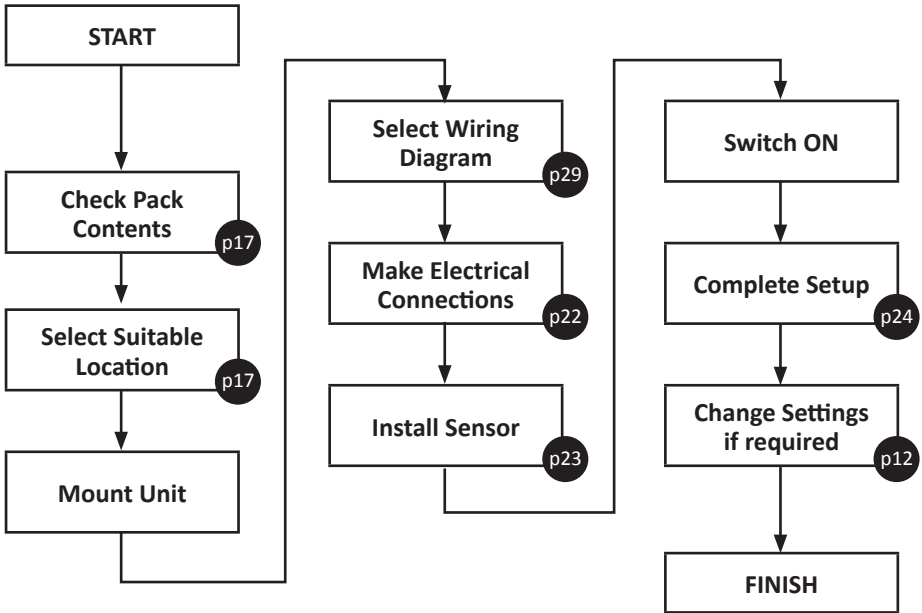

Heat Pumps and Solar Thermal – Legionella Control

Heat pumps often need to use the immersion heater to get the hot water to a high temperature for the purpose of Legionella control. This is an ideal application for the External Boost input.

The immersion heater should ONLY be connected to the immerSUN, do not connect the immersion heater to the heat pump or solar thermal controller.

ON/OFF Control of Other Appliances

Only resistive loads (e.g. heaters) can be connected to the variable power Heater 1 and Heater 2 outputs. However, it is possible to simply switch ON/OFF other types of devices by using the Threshold option of the Multifunction Relay.

Cylinder Destratification

The effective capacity of a hot water cylinder with a top mounting immersion can be increased by pumping the hot water to the bottom of the cylinder, therefore allowing the immersion heater to heat the top section of the cylinder again. The Multifunction Relay has a De-strat Pump control option for this purpose.

What's in the Pack

- immerSUN
- Installation and User Guide
- Sensor Clamp with connected 5m cable
- Connector Plugs
- Fixing Kit
- Antenna

Locating the immerSUN

Often, the most suitable location for the immerSUN is near to the distribution board as all the connections required are usually available here.

Alternatively the unit can be mounted next to the load. Note that the Sensor Clamp must be clamped around the incoming mains electrical supply. There is the option of using the Wireless Sensor to simplify the installation if required.

The following should be considered when deciding upon the most suitable location:

- Close to the main incoming mains electrical supply of the property – otherwise the Sensor Clamp will need to be extended, or the Wireless Sensor option used.
- Access to heater supply cable (this is usually at the switchboard)
- Access to suitable supply via 16A MCB or 13A fused outlet
- User access to the buttons and visibility of LCD screen
- Adequate ventilation – keeps vents clear and provide airflow around the unit
- Minimum clearance top and bottom is 50mm although more is recommended for ease of access to case screws.
- Cable access point – through the top, bottom or rear of the unit- the bottom panel is removable to give better access when wiring.

Voltage Optimisers

If there is a voltage optimiser installed at the property, care will need to be taken when positioning and wiring the immerSUN. The Sensor Clamp and the immerSUN will need to 'see' the same voltage, whether this is the optimised voltage or the non-optimised voltage.

Check the manufacturers instructions before connecting the immerSUN to an optimised circuit – some optimisers should not be connected to heaters.

Three-Phase Systems

The immerSUN and the Sensor Clamp must be on the SAME PHASE.

If the generation is 3-phase, an immerSUN can be used on each phase, if only one or two immerSUN's are used, only one-third or two-thirds of the surplus power will be able to be utilised. The loads will need to be single phase.

System Overview

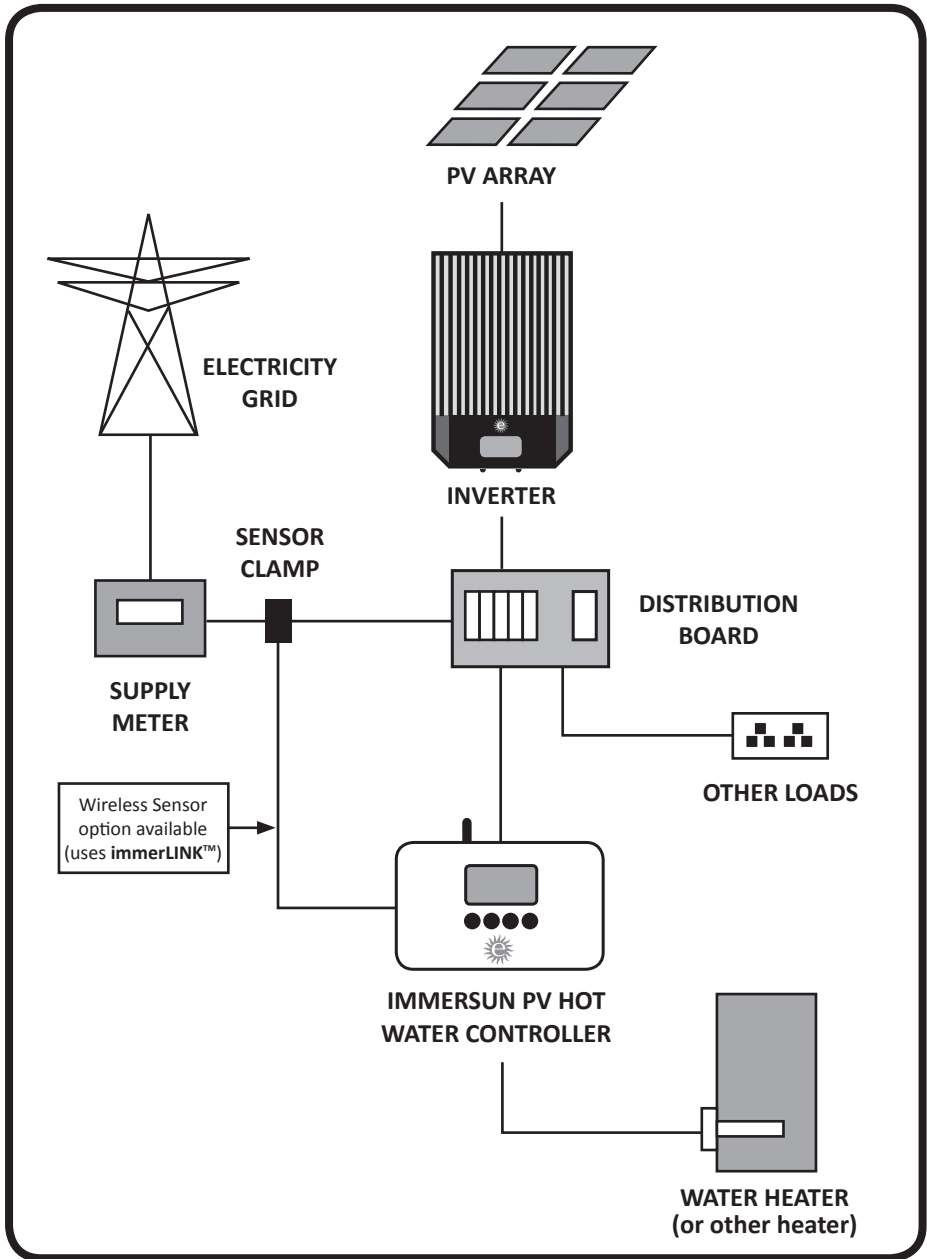

immerLINK™ (Linking Units)

immerLINK™ is a wireless network used by immerSUN devices.

Up to 5 immerSUN units can be 'linked' together by using immerLINK™.

Linking several units enables more export power to be consumed, with each device being able to control a 3kW load, up to 15kW of would-be exported power can be utilised. Use the immerLINK Search option in the **Advanced Menu** to link devices.

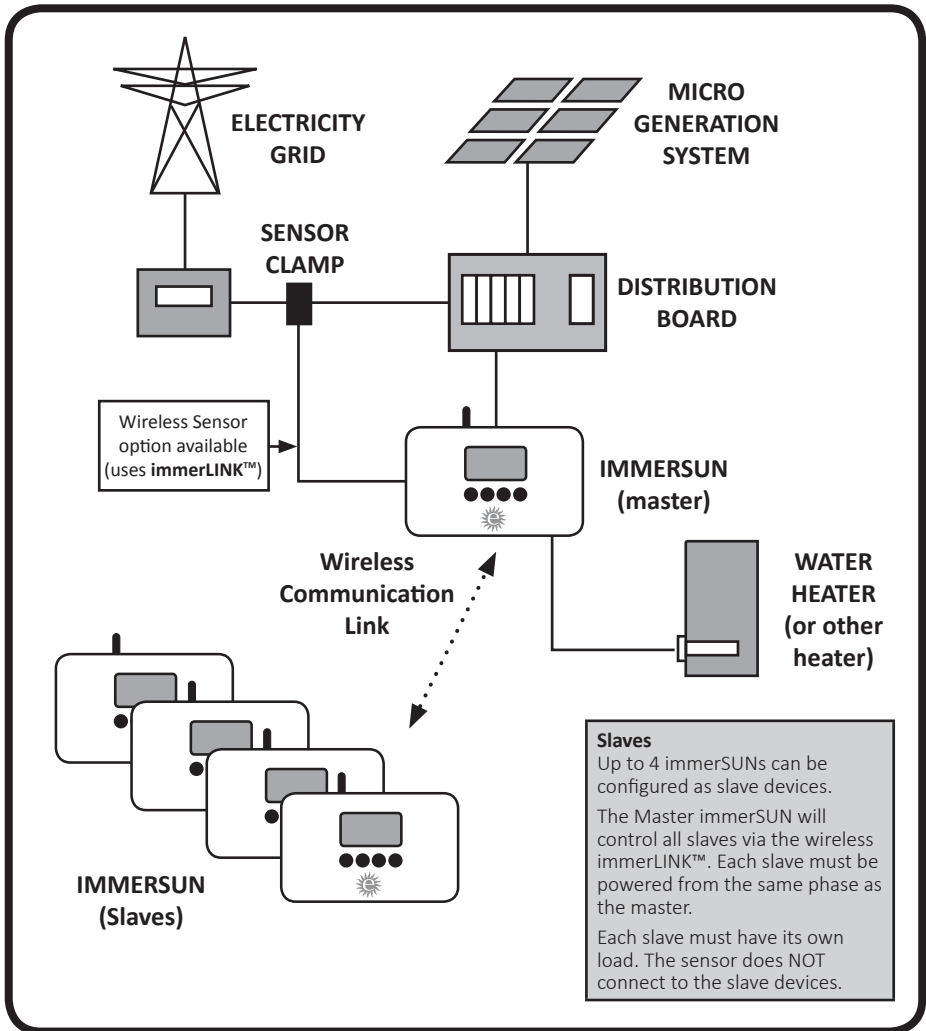

immerSUN™ at a Glance

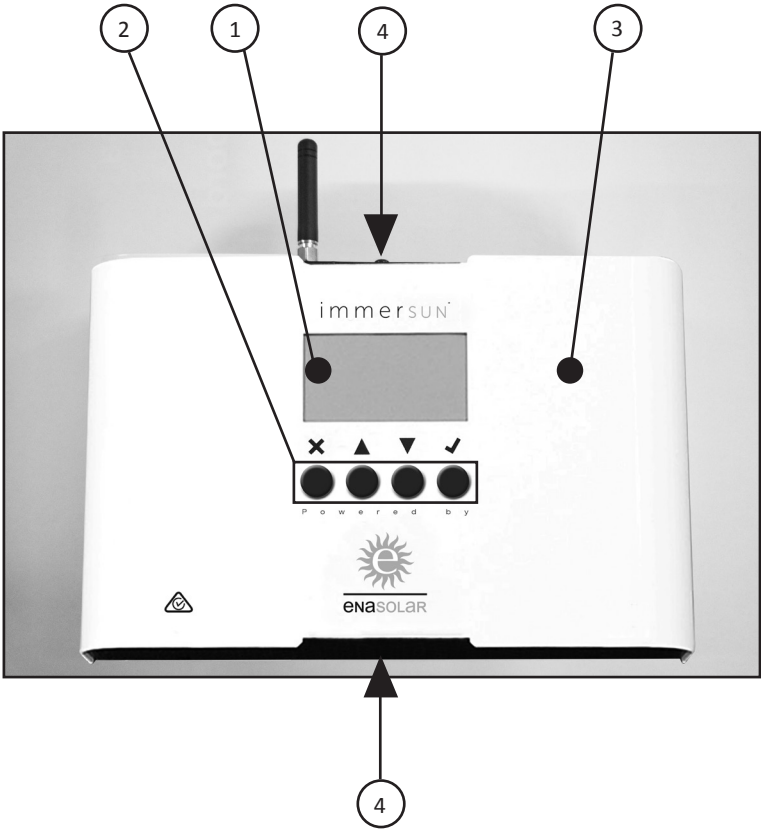

External overview

- 1) LCD display
- 2) Control buttons
- 3) Cover (removable)
- 4) Cover screws

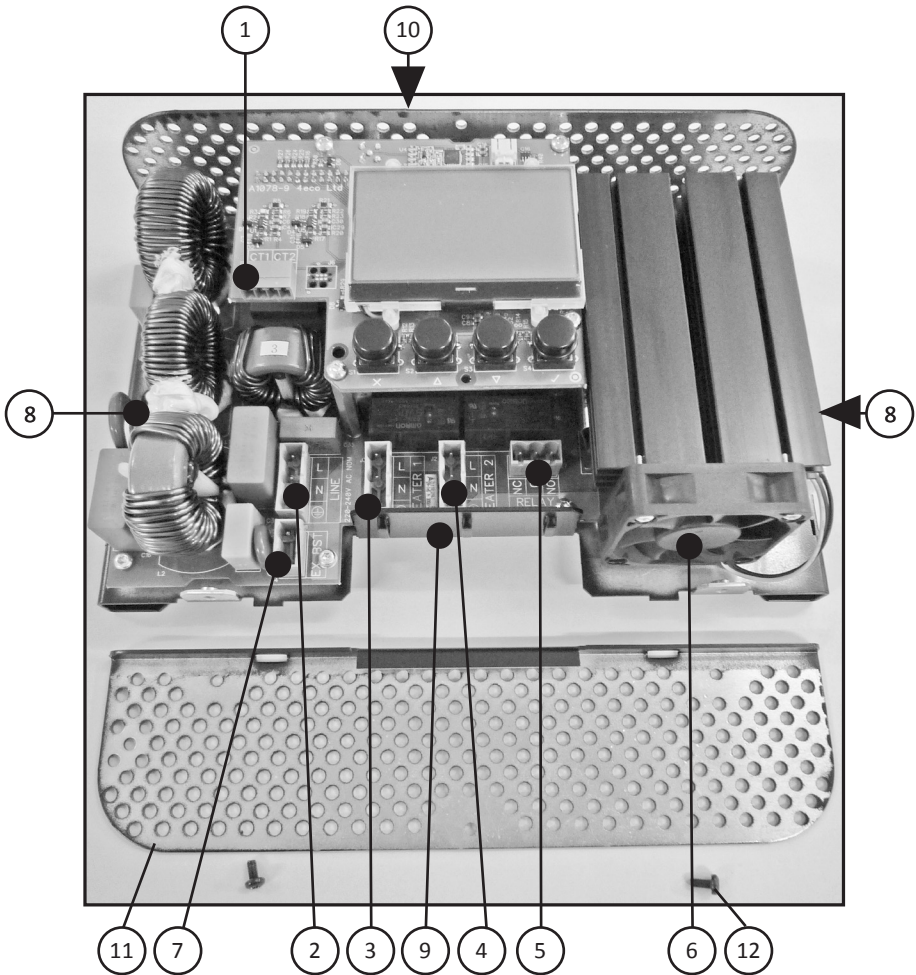

Cover and Bottom Panel Removed

- | | |
|--------------------------------|----------------------------------|
| 1) Sensor Clamp | 7) EX BST – External Boost input |
| 2) LINE – mains supply input | 8) Mounting holes |
| 3) HEATER 1 | 9) Cable anchor points |
| 4) HEATER 2 | 10) Antenna connector |
| 5) RELAY – Multifunction Relay | 11) Bottom panel (removable) |
| 6) Cooling fan | 12) Bottom panel screws |

Electrical Connections

The electrical connections are made by the pluggable screw terminals.

See **Wiring Diagrams** section and choose the most appropriate wiring scheme for the installation.



Important!

Ensure that the heater element is 3kW or less. If unsure check the element resistance with a multi-meter (with power disconnected). The element resistance must be 16Ω or more.

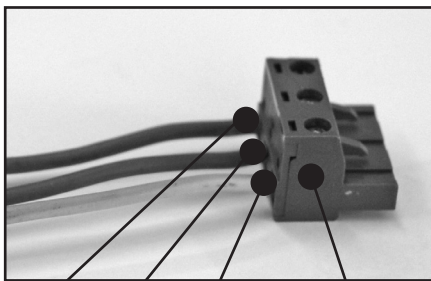
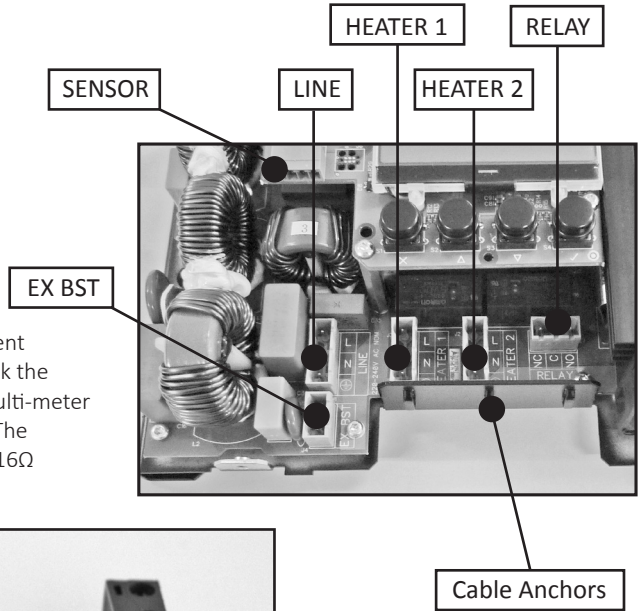

L N E

Plug-in
Screw Terminals



Important!

- Earth MUST be connected
- Ensure wires are secure in screw terminals
- Check plugs are fully inserted
- Secure cables to the cable anchor points with the cable-ties provided

Sensor Installation

The sensor should be located at the incoming grid supply to the building. This will be the supply from the electric supply meter (NOT the PV generation meter). Clamp the sensor around the LIVE from the meter. Ensure the clamp is securely closed around the cable.

It does not matter which way round the sensor is clamped around the cable, the immerSUN will work out the import/export direction automatically.

Normally, the sensor will be located inside the switchboard since this is the most practical place to install it and route the cable to the immerSUN.

PV connected via Henley Block

If the PV system is connected via a terminal then the clamp should be installed on the grid side of the block, i.e. between the meter and terminal block.

More than one consumer unit

Where there is more than one consumer unit, the clamp should be installed at the primary incoming supply (i.e. before it splits).

Using the Wireless Sensor (Optional)

There is an option to use a wireless sensor. The wireless sensor is available to purchase as an optional extra. When using the wireless sensor option, the sensor clamp should NOT be connected directly to the immerSUN. See the installation instructions for the Wireless Sensor.

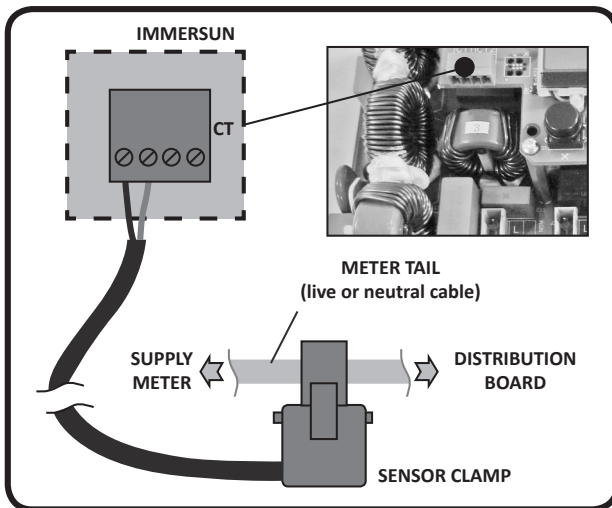

Ensure that the CT plug is wired to the correct polarity, and inserted into position CT1.

Note: The sensor has a fixed, non-removable cable of approximately 4mm diameter and 5m long that will need to be routed from the clamp location to the immerSUN.

Note: The CT cable can be extended up to 100m using a twisted pair cable (e.g. 1 pair of Cat 6)..

Setup

The immerSUN requires an initial set-up to ensure that the direction of grid power (import and export) is correctly registered by the unit. To achieve this, a resistive load must be connected to Heater 1 on the immerSUN and must be turned on for the 2-5 minutes that it takes to complete the configuration.

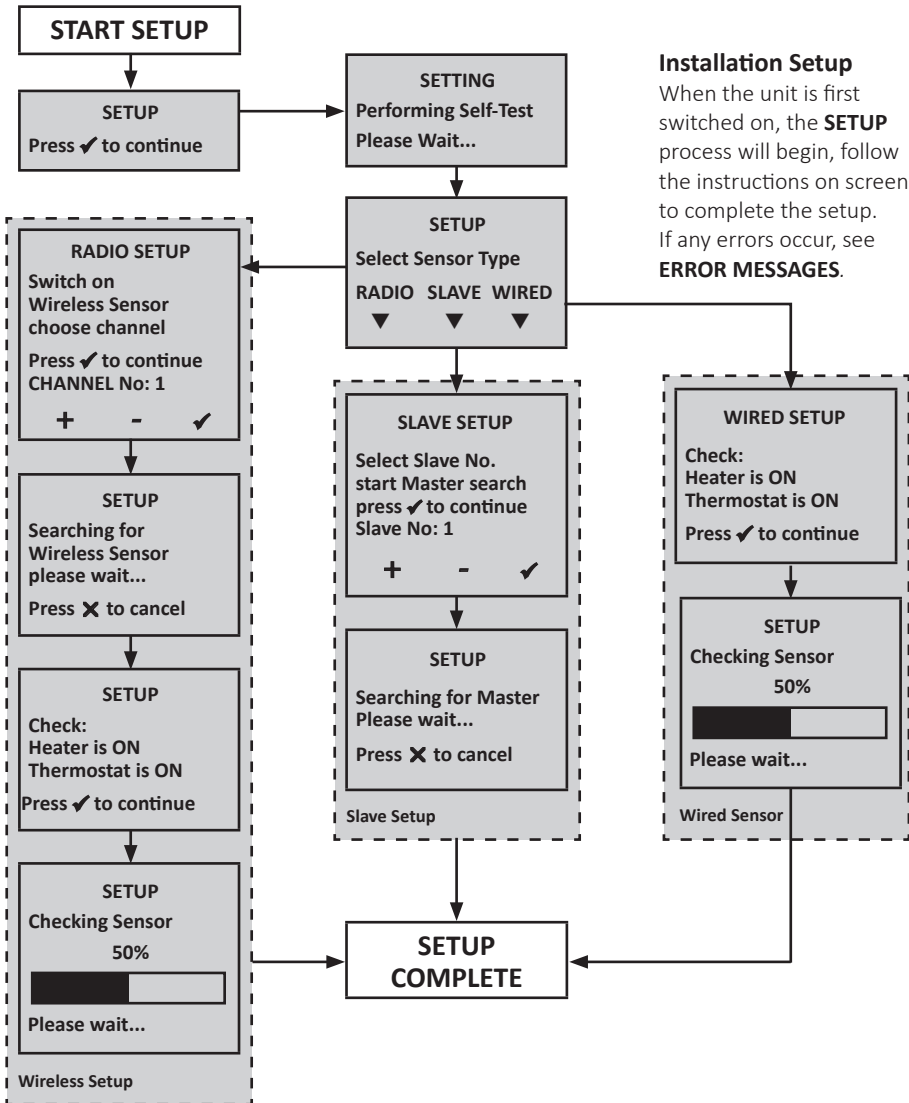

Installation Setup

When the unit is first switched on, the **SETUP** process will begin, follow the instructions on screen to complete the setup. If any errors occur, see **ERROR MESSAGES**.

Setting up an ImmerSUN when not using heater outputs

When there is a requirement to use only the multi-function relay, the immerSUN still requires initial configuration so that the grid power direction (import and export) is correctly registered by the unit.

With no resistive element permanently present under this circumstance, a temporary load needs to be provided during the set-up process only.

This can be achieved by temporarily wiring a resistive-only load (of less than 3.0kW >150W) to the Heater 1 terminal plug, conducting the set-up process, and then removing it.

Once the set-up is complete, and providing the sensor clamp is not relocated, the immerSUN will continue to correctly monitor and measure the grid power, even after a power outage situation.

1. Manufacture a suitable temporary, resistive-only load. An electric jug or radiant heater (without electronic controls or fans) is suitable.
2. Connect this temporary load to the Heater 1 terminal plug and follow the standard set-up process on page 24.
3. Disconnect the temporary load and confirm correct operation of the immerSUN.

EnaSolar Monitoring and Reporting

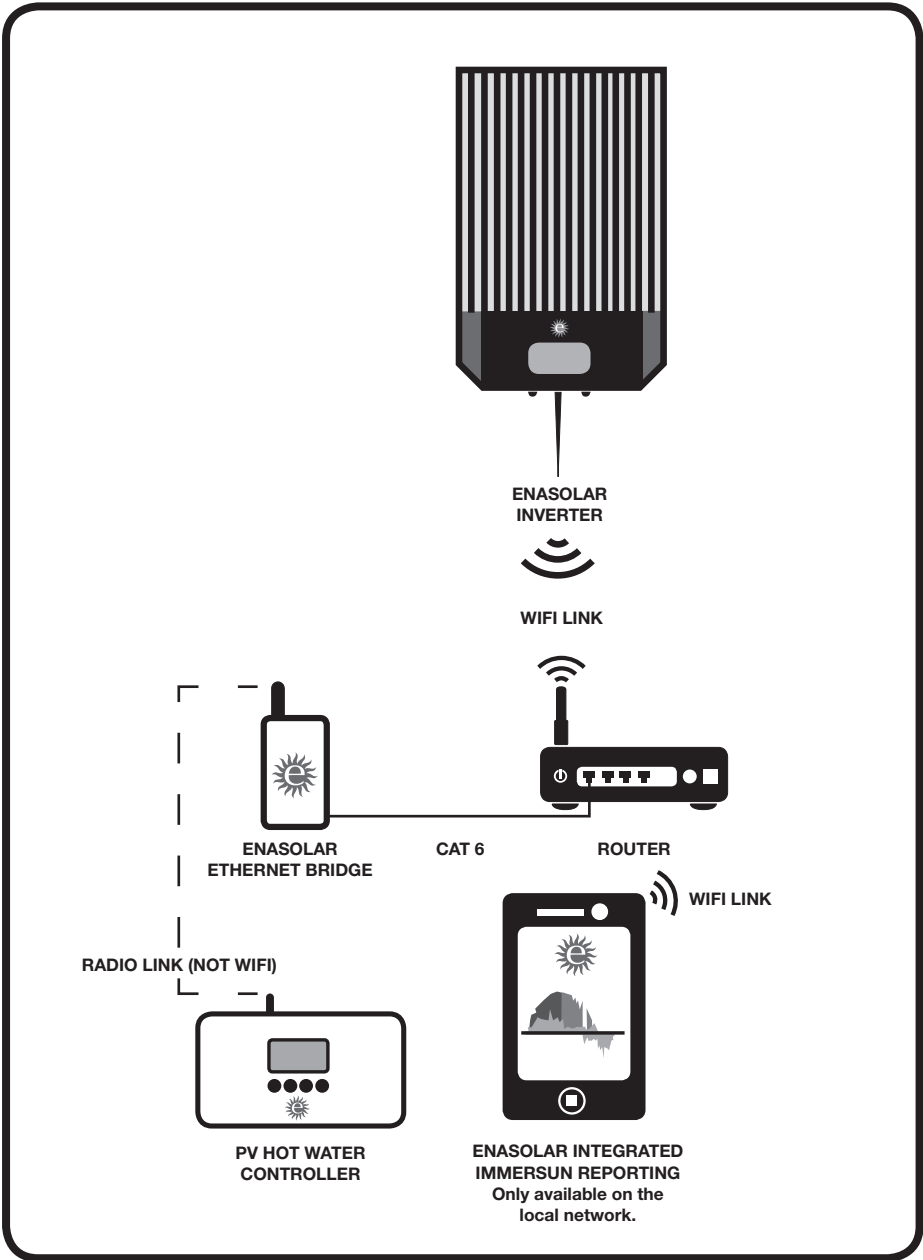

Configuring an EnaSolar Site

You will Need:

For an existing EnaSolar inverter installation: An ImmerSUN Controller, EnaSolar Ethernet Bridge, a new display PCB, mini B USB cable, and a laptop with the EnaSolar Solar Installation Utility (V3.21 or greater).

For a new EnaSolar inverter installation: An ImmerSUN Controller, EnaSolar Ethernet Bridge, mini B USB cable, and a laptop with the EnaSolar Solar Installation Utility (V3.21 or greater).

1. Install and configure the ImmerSUN Controller as per **Page 16** of the **Installation and User Guide**, power up and configure as per the screen instructions.
2. Using the EnaSolar Solar Installation Utility (V3.21 or greater) on a laptop, connect to the existing front panel of the inverter with a mini B USB cable.



For an existing site please continue to Step 3, for a new installation please go Step 6.

3. Go to **Advanced Settings, Other, Read**.
Then **Other, Stop LED**.
4. Change the display PCB on the inverter to the new one, and plug back into the inverter (don't screw the front panel to the inverter yet).
5. Connect the mini B USB cable to the new front panel and select **Write** on the Solar Installation Utility to copy all the existing data to the new display board.
6. Go to **Setup, Click to Set Time** and go to **Wireless Setup** and set up wifi. Disconnect the USB cable and screw the front panel back on the inverter.
7. Connect the EnaSolar Ethernet Bridge (RJ45/CAT6) to the home network/router and to the power.
8. Set up in the immerSUN Controller - **Tariff - Set Currency** to **\$**. Set tariff to the cost of your power.
9. Set up in the immerSUN Controller - **Advanced Settings**
immerLINK
immerLINK search
Channel No. (Set to a number between 1-8).
10. Press the button on the EnaSolar Ethernet Bridge until the LED starts flashing red, then orange, then, eventually turns green. The immerLINK search screen should now show **Bridge Found**. Exit (x). If Bridge Found is not displayed the bridge may need to be positioned closer to the immerSUN Controller, also check that the antennas are firmly secured on both units.
11. Repower the inverter.
12. Tap the front screen of the inverter until the water heater screen is displayed. It should display **Connected**. If Connected is not displayed please see PV Hot Water Error Messages on page 28. These issues need to be fixed before moving to the next step.
13. Display the web page on the inverter, it should be displaying the PV hot water, inverter generation, total consumption, grid export, inverter input 1 and inverter input 2 data.
14. Set up boost times and relay functions on the ImmerSUN Controller if required by the customer.

PV Hot Water Messages, as displayed on the inverter LCD

- **DISABLED** - After 10 minutes of not FINDING, the inverter will display **DISABLED** if an Ethernet Bridge has never been connected. To fix, turn the power to the inverter off (display goes blank) then on, the inverter should now search for the PV hot water again.
- **INVERTER NETWORK DISCONNECTED** - The wifi or ethernet connection between the inverter and router is disconnected. Fix this first.
- **FINDING** - The inverter is trying to connect to the Ethernet Bridge.
 - **CANNOT FIND** - The inverter cannot find the Ethernet Bridge, check the Ethernet Bridge is powered on and the ethernet cable connected. Also check the inverters network settings. Check that the LEDs on the Bridge Ethernet connector are flashing yellow and steady green. This indicates connection to the router.
- **FOUND** - The inverter has connected to the bridge.
 - **FINDING/CONNECTION ISSUE** - The inverter is able to talk to the Ethernet Bridge but the bridge is unable to talk to the immerSUN Controller. Retry Step 9 and 10. If the Bridge has previously been connected, then the “immerLINK Search” feature may now show Bridge: FOUND, with no option to re-search. In this case, it will be necessary to reset the immerLINK functionality. Go to Advanced Settings- Factory Reset and select “reset immerLINK” (only) and execute the reset.
- **FOUND/CONNECTION ISSUE** - The inverter has connected to the Ethernet Bridge but cannot connect to immerSUN Controller. Retry Step 9 and 10 and check the aerial connections and that there is a good signal path.
- **CONNECTED** - Success.
- **COMMS ERROR** - There is an issue with the internal communications of the inverter’s display. If this stays displayed check the cable between the display module and the inverter is well plugged in.

LED indications on Ethernet Bridge

- LAN**  **Red** - No Ethernet connection. Check connection to router.
Red Flashing - Trying to get a network connection.
Green - O.K. Connected to router and internet.
- Radio**  **Red** - No signal being received from immerSUN. Check aerials are connected and that there is a good signal path.
Red, flashing - In process of connecting to immerSUN.
Orange - Connected to immerSUN immerSUN will display **BRIDGE FOUND**
Orange/Flashing Green - Data is being sent to and from the immerSUN and the inverter.

Normal operational indications:

- EnaSolar** - PV Hot Water
Inverter - Connected
LAN LED - Orange or Green
Radio LED - Orange/Flashing Green

Wiring Diagrams...

DISCLAIMER: These wiring diagrams show typical examples. It is up to the installer to ensure the installation conforms to the appropriate wiring regulations and network connection standards.

Wiring: Single Heater

1

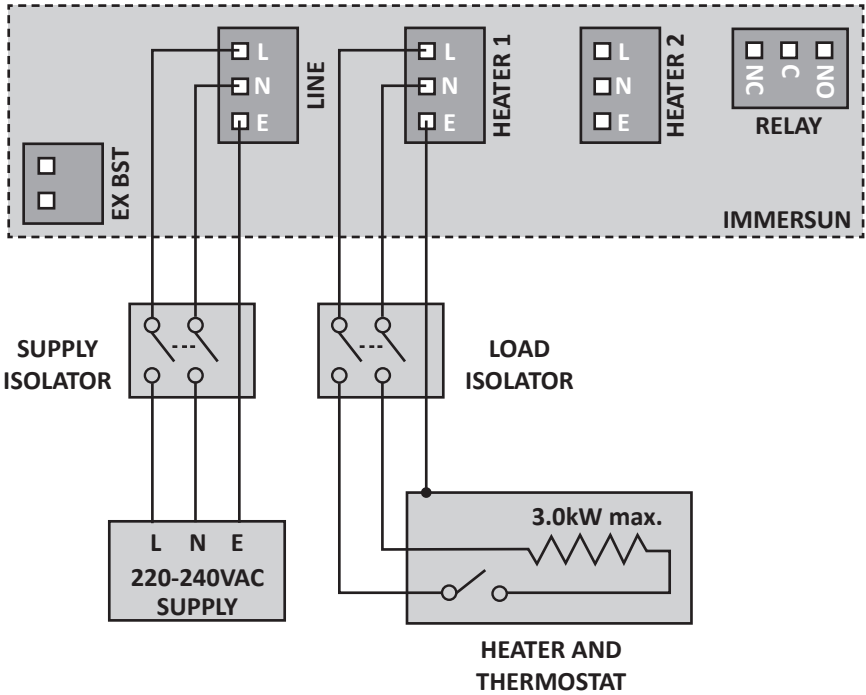



Single Heater Wiring

This is the most simple installation and the most common. One heater is wired to the Heater 1 output.

The heater is heated with surplus power until the thermostat opens, the immerSUN will then display HOT. The surplus power will then be exported until the thermostat closes and heating will resume.

Isolators

The isolators shown may not be required but there should always be a way of isolating the supply, e.g. the MCB can be used for isolation, if the immerSUN is located next to the consumer unit. Likewise, the load isolator can be eliminated if the immerSUN and the supply isolation switch are located near the heater.



Important!

- Maximum load: 3.0kW
- Minimum load: 150W
- Recommended cable size: 2.5mm²
- Must be a simple resistive load without electronic controls



Settings

Heater 1 Type: Set to match the load

Heater 2 Type: None

Heater 3 Type: None

Relay Function: Not used

External Boost: Not used



Tips and Ideas

- Smaller loads can be connected in parallel as long as the maximum load is not exceeded.
- The immerSUN has built-in timers that can replace any timers that have been removed.
- The Multifunction Relay is free to use to control other devices.
- The External Boost input is free to use if an auxiliary device needs to have some control over the immerSUN.

Wiring: Two Heater

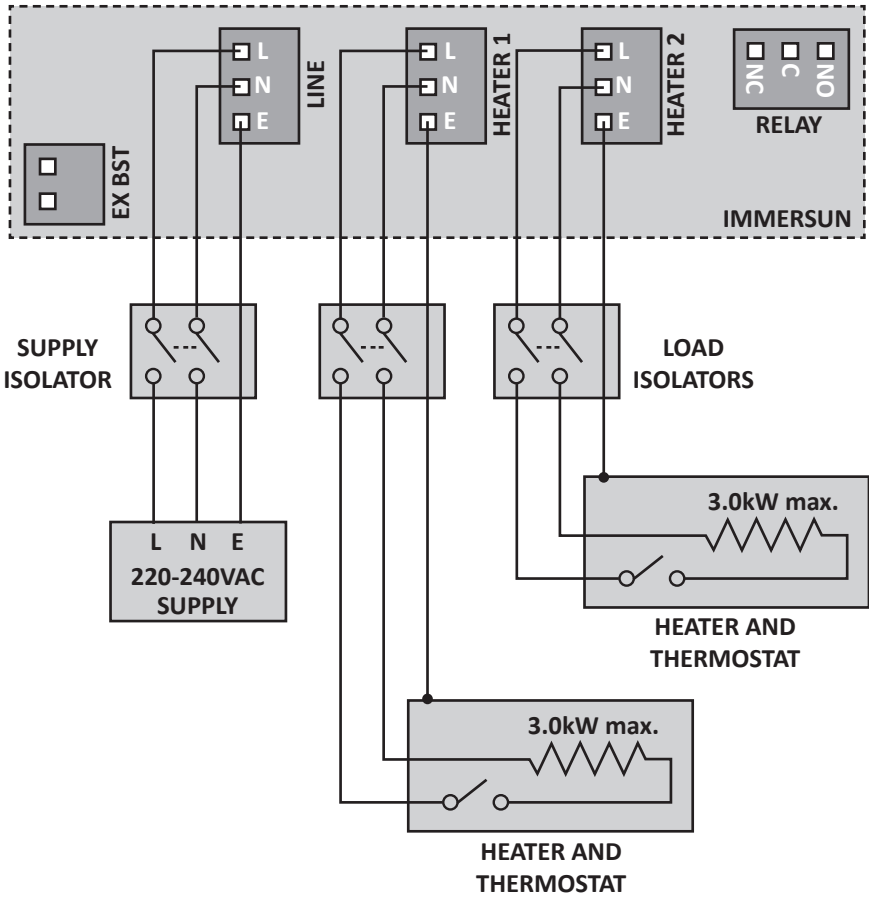



Two Heater Wiring

This is the same as the Single Heater wiring, only with a second heater connected. One heater is wired to the Heater 1 output, a second heater is wired to the Heater 2 output.

The heaters are heated sequentially, i.e. Heater 1 is heated with surplus power until the thermostat opens, the immerSUN will then display HOT. After a few seconds, (providing export power is still available), Heater 2 will start to be heated. If Heater 2 reaches maximum temperature, the display will show HOT and the immerSUN will switch back to Heater 1.

During heating of the lower priority heater, the immerSUN will switch to the higher priority heater periodically to check if it can take more heat. The heating priority can be set in the Main Menu (Set Priority). Also the period of time between heater 'checks' can be set in the Advanced Settings Menu (Priority Check).

When both heaters are HOT any surplus power will be exported.



Important!

- Maximum load: 3.0kW (each heater)
- Minimum load: 150W (each heater)
- Recommended cable size: 2.5mm²
- Must be a simple resistive load without electronic controls



Settings

Heater 1 Type: Set to match the load

Heater 2 Type: Set to match the load

Heater 3 Type: Disabled

Relay Function: Not used

External Boost: Not used



Tips and Ideas

- Smaller loads can be connected in parallel as long as the maximum load is not exceeded.
- The immerSUN has built-in timers that can replace any timers that have been removed.
- The Multifunction Relay is free to use to control other devices.
- The External Boost input is free to use if an auxiliary device needs to have some control over the immerSUN.

Wiring: Three Heater

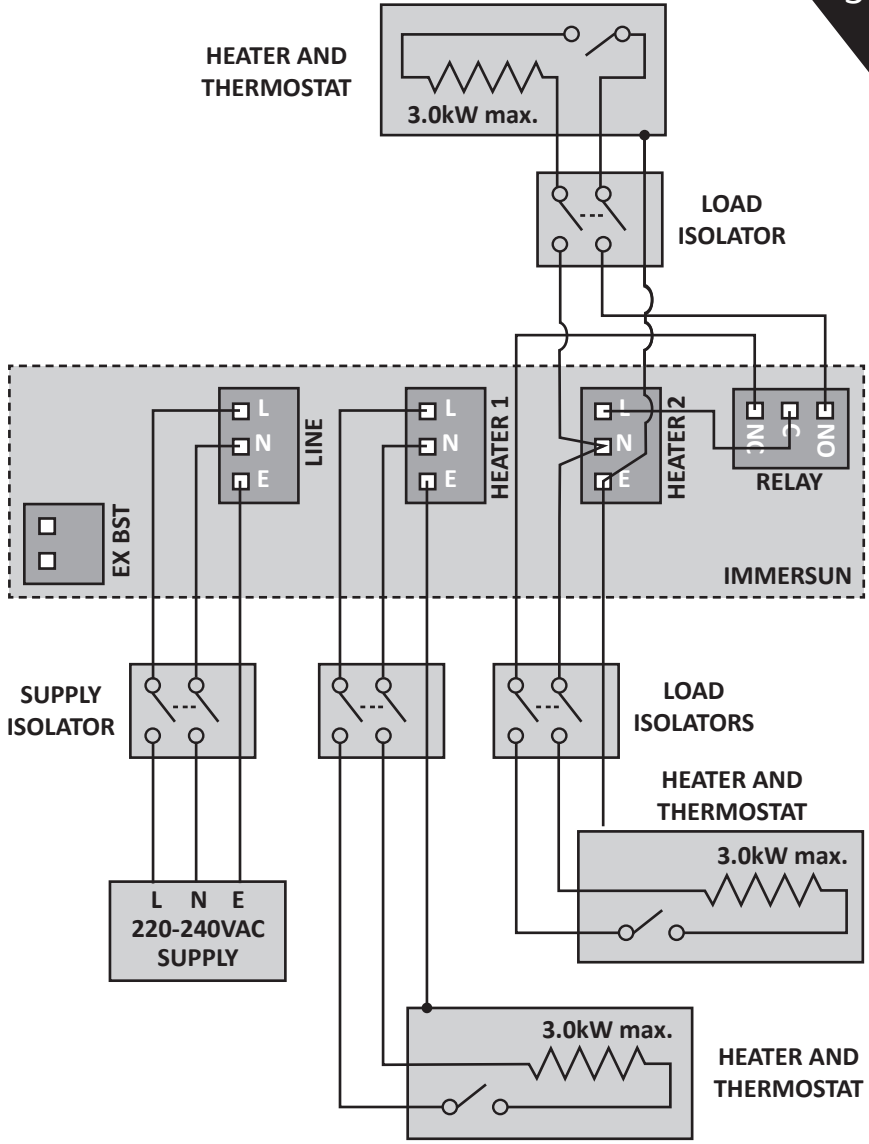



Three Heater Wiring

By making use of the Multifunction Relay it is possible to connect 3 heaters. One heater is wired to the Heater 1 output, the Heater 2 output is wired to the Common of the relay, the other two heaters are then connected to the Normally Open and Normally Closed contacts.

The heaters are heated sequential, i.e. Heater 1 is heated with surplus power until the thermostat opens, the immerSUN will then display HOT. After a few seconds, (provided export power is still available), Heater 2 will start to be heated. If Heater 2 reaches maximum temperature, the display will show HOT and the immerSUN will switch the relay over so that Heater 3 can be heated.

During heating of a lower priority heater, the immerSUN will switch to the higher priority heater periodically to check if it can take more heat. The heating priority can be set in the Main Menu (Set Priority). Also the period of time between heater 'checks' can be set in the Advanced Settings Menu (Priority Check).



Important!

- Maximum load: 3.0kW (each heater)
- Minimum load: 150W (each heater)
- Recommended cable size: 2.5mm²
- Must be a simple resistive load without electronic controls



Settings

Heater 1 Type: Set to match the load

Heater 2 Type: Set to match the load

Heater 3 Type: Set to match the load

Relay Function: Third Heater

External Boost: Not used



Tips and Ideas

- Smaller loads can be connected in parallel as long the maximum load is not exceeded.
- The immerSUN has built-in timers that can replace any timers that have been removed.
- The External Boost input is free to use if an auxiliary device needs to have some control over the immerSUN.

Wiring: Underfloor Heating (Opt. 1)

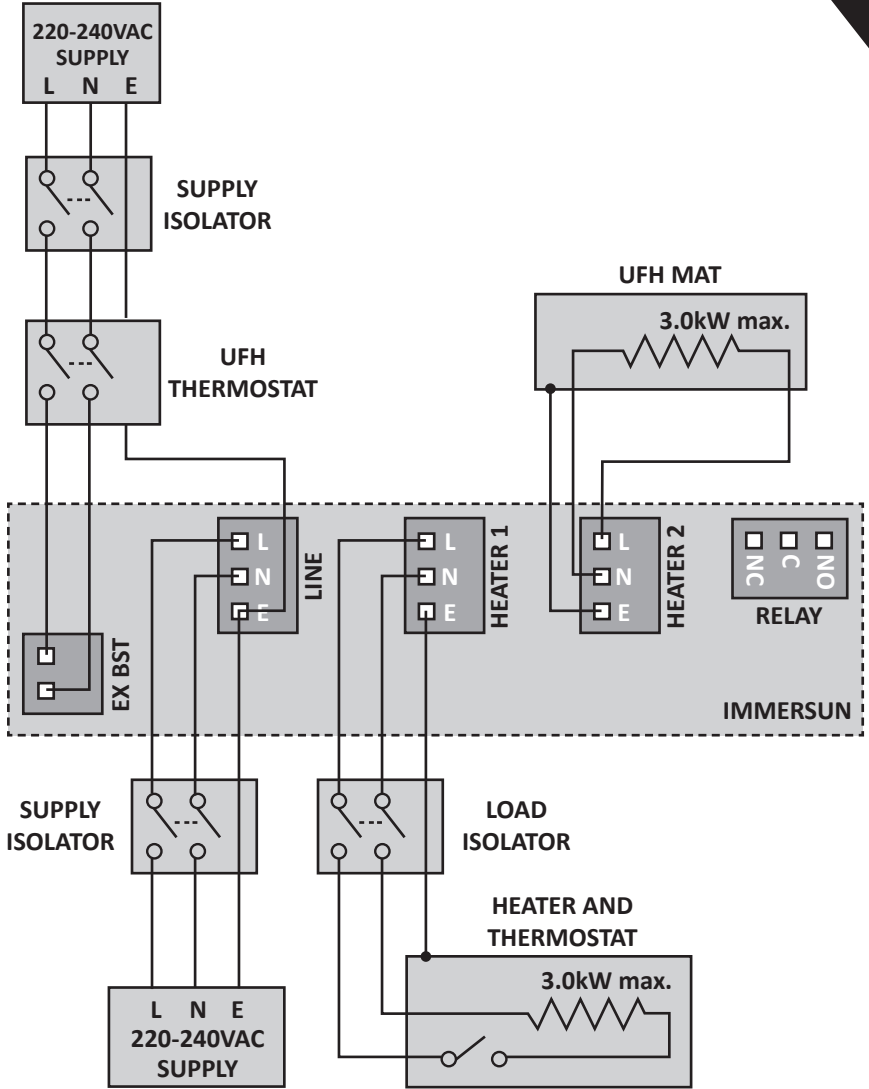



Underfloor Heating – Option 1

Electric underfloor heating (UFH) can usually be used with the immerSUN. This wiring diagram assumes that the UFH is to be used alongside another heater (most likely an immersion heater). However the UFH system can be used as the only heater by wiring to the Heater 1 output.

The UFH thermostat is wired so that the External Boost sees a voltage when the thermostat is closed. The UFH mat is connected directly to Heater 2 output.

The External Boost input is used in ‘thermostat’ mode so that the Heater 2 output is active only when the UFH thermostat is calling for heat.

By utilising this wiring and configuration, the thermostat could be of any type, since it is only providing a signal input to the immerSUN, and does not form any part of the immerSUN variable voltage output circuitry.



Important!

- Maximum load: 3.0kW (each heater)
- Minimum load: 150W (each heater)
- Recommended cable size: 2.5mm²
- Must be a simple resistive load without electronic controls



Settings

Heater 1 Type: Set to match the load

Heater 2 Type: Underfloor Heating (resistive load only)

Heater 3 Type: Disabled

Relay Function: Not used

External Boost: Heater Thermostat: Heater 2



Tips and Ideas

- Smaller loads can be connected in parallel as long as the maximum load is not exceeded.
- The immerSUN has built-in timers that can replace any timers that have been removed.
- The Multifunction Relay is free to use to control other devices.

Wiring: Underfloor Heating (Opt. 2)

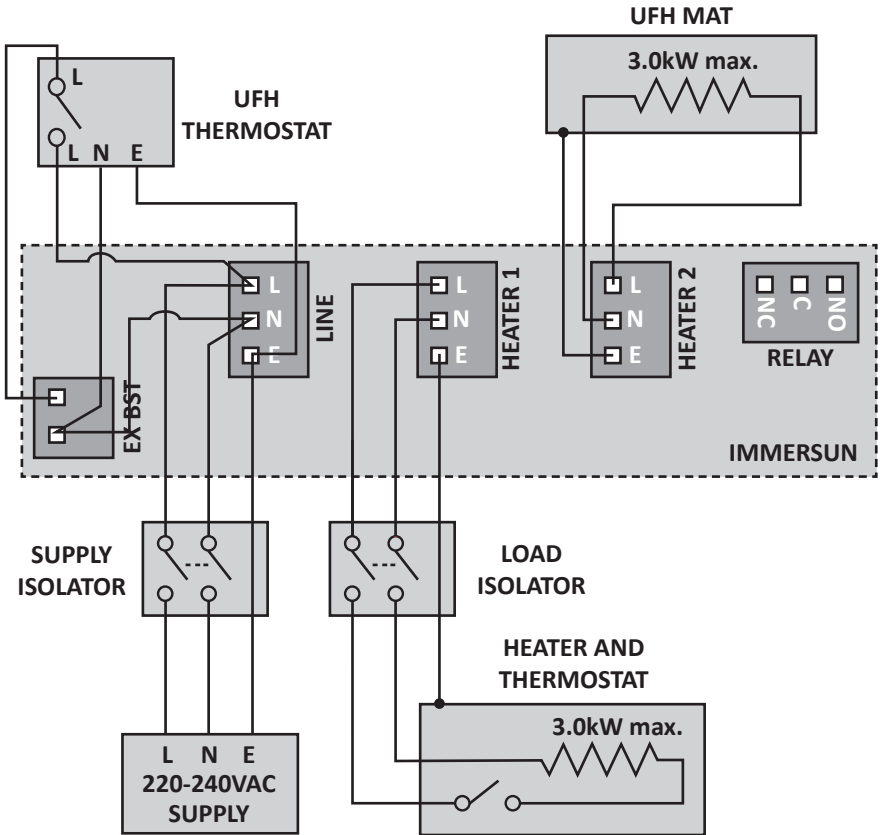



Underfloor Heating – Option 2

Electric underfloor heating (UFH) can usually be used with the immerSUN. This wiring diagram assumes that the UFH is to be used alongside another heater (most likely an immersion heater). However the UFH system can be used as the only heater by wiring to the Heater 1 output.

The UFH thermostat is wired solely to the immerSUN, power is taken from the immerSUN supply and External Boost input is used to sense the UFH thermostat state. The UFH mat is connected directly to Heater 2 output.

The External Boost input is used in 'thermostat' mode so that the Heater 2 output is active only when the UFH thermostat is calling for heat.

By utilising this wiring and configuration, the thermostat could be of any type, since it is only providing a signal input to the immerSUN, and does not form any part of the immerSUN variable voltage output circuitry.



Important!

- Maximum load: 3.0kW (each heater)
- Minimum load: 150W (each heater)
- Recommended cable size: 2.5mm²
- Must be a simple resistive load without electronic controls



Settings

Heater 1 Type: Set to match the load

Heater 2 Type: Underfloor Heating (resistive load only)

Heater 3 Type: Disabled

Relay Function: Not used

External Boost: Heater Thermostat: Heater 2



Tips and Ideas

- Smaller loads can be connected in parallel as long as the maximum load is not exceeded.
- The immerSUN has built-in timers that can replace any timers that have been removed.
- The Multifunction Relay is free to use to control other devices.

Wiring: Dual Tariff (Single Meter)

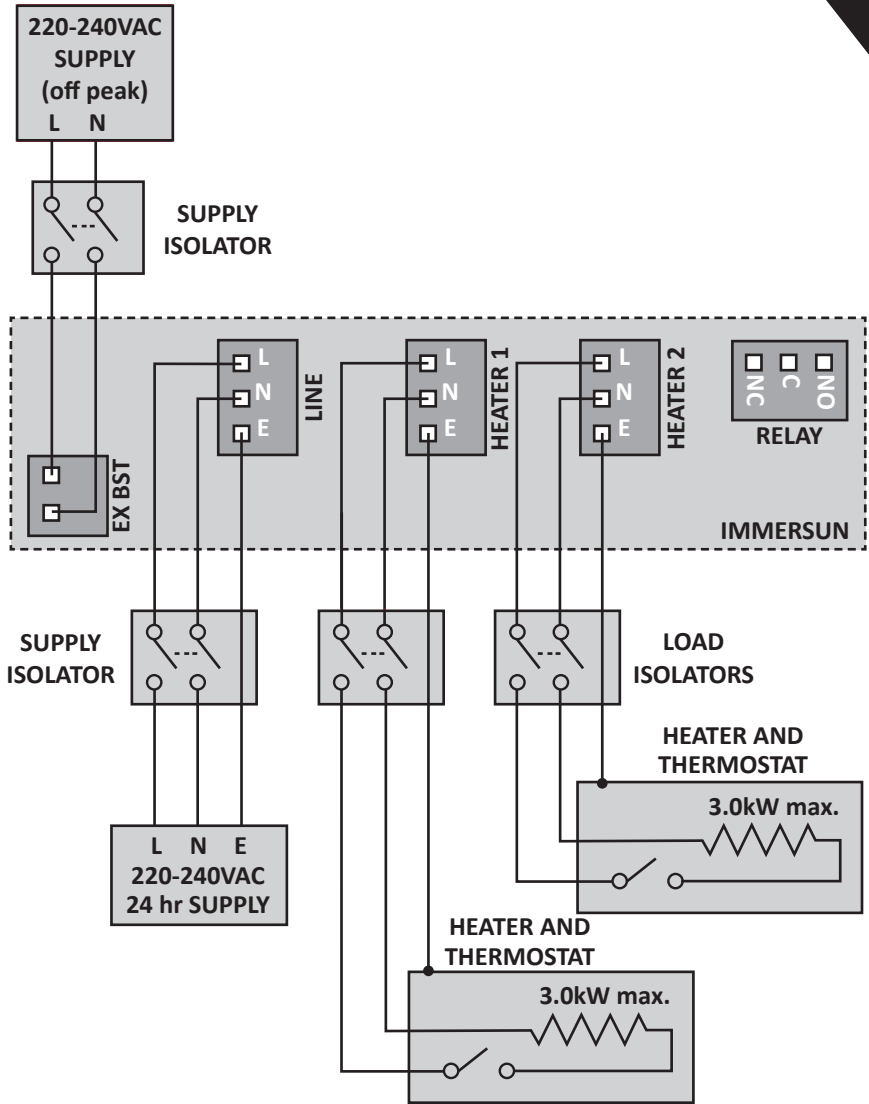



Dual Tariff Wiring – Single Meter

It is simple to wire the immerSUN to handle dual rate tariffs when there is only one supply meter. The External Boost input can be used to detect when the economy rate electricity is available and automatically boost the heater output.

Note that: the heater will **always** be boosted while there is voltage present on the EXT BST connector.

The Heaters are connected to the Heater 1 and 2 outputs as normal. The External Boost input is connected to the economy rate supply.



Important!

- Maximum load: 3.0kW (each heater)
- Minimum load: 150W (each heater)
- Recommended cable size: 2.5mm²
- Must be a simple resistive load without electronic controls



Settings

Heater 1 Type: Set to match the load

Heater 2 Type: Set to match the load

Heater 3 Type: Disabled

Relay Function: Not used

External Boost: Boost Heater: Heater 1 & 2



Tips and Ideas

- By changing the External Boost heater number, the user can select Heater 1, Heater 2 or both to be automatically boosted whenever the economy rate tariff is available.
- Rather than connecting the External Boost, it is possible to simply program the boost times to coincide with the economy rate times.
- Smaller loads can be connected in parallel as long as the maximum load is not exceeded.
- The immerSUN has built-in timers that can replace any timers that have been removed.
- The Multifunction Relay is free to use to control other devices.

Wiring: Dual Tariff (Two Meter)

E.G. Ripple Controlled Circuit

7

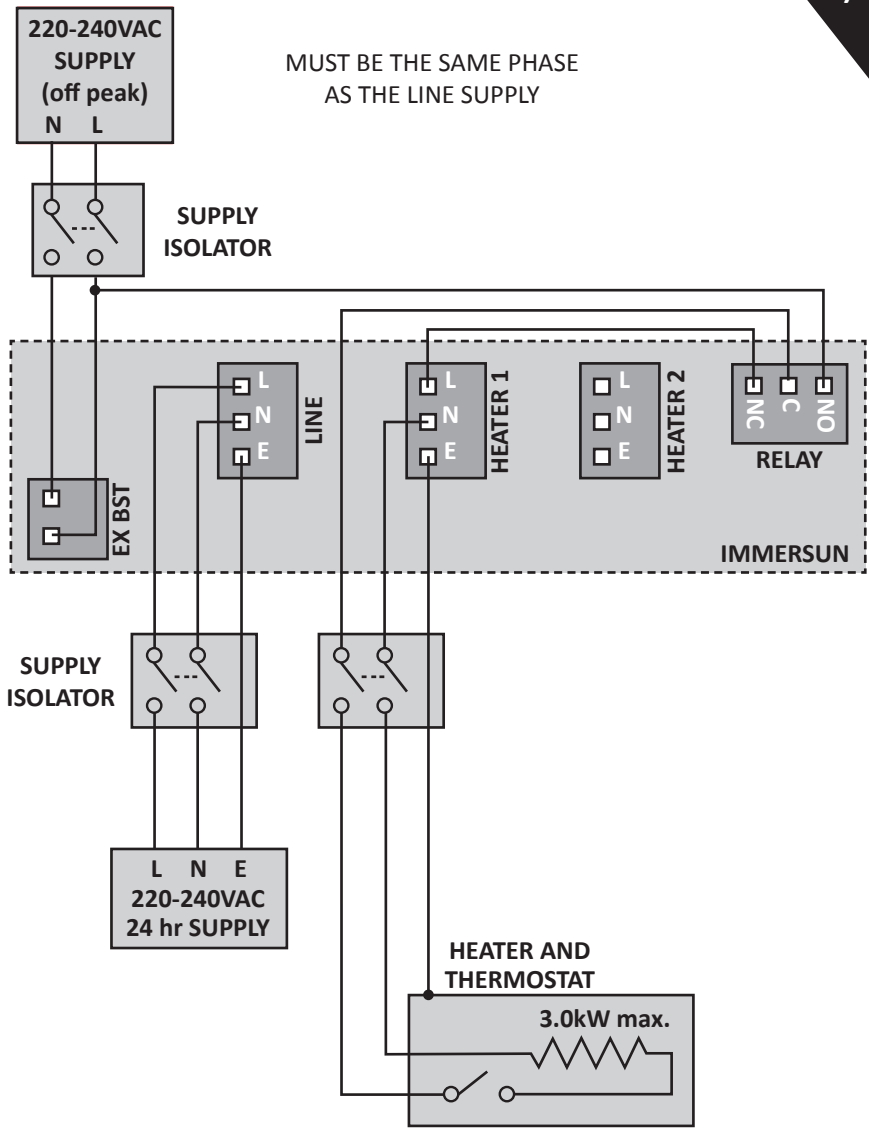



Dual Tariff Wiring – Two Meter

If there are two meters at the property, for dual tariff metering, it is necessary to make sure that power is drawn from the correct meter.

The immerSUN must be powered from a 24-hour supply and the heater must be connected directly to the immerSUN, however, during the economy tariff times, the heater needs to draw power from the economy tariff meter.

This can be achieved by switching the heater from the immerSUN output to the economy supply during the times when the economy supply is available. The multifunction relay can be used to achieve this but only where there is no RCD fitted to the water heater.

With this configuration, only Heater 1 will be able to be billed at the economy rate.



Important!

- Maximum load: 3.0kW (each heater).
- Minimum load: 150W (each heater).
- Recommended cable size: 2.5mm².
- Must be a simple resistive load without electronic controls.
- Ensure there is no RCD fitted to the water heater circuit.
- The offpeak supply MUST be the same phase as the Line Supply.



Settings

Heater 1 Type: Set to match the load. This is the heater that is heated by PV or the economy tariff.

Heater 2 Type: Set to match the load

Relay Function: Set to: When boosting, Heater 1

External Boost: Set to: Boost Interlock, Heater 1

Boost Times: Set boost times to match household use.



Tips and Ideas

- Smaller loads can be connected in parallel as long as the maximum load is not exceeded.
- The immerSUN has built-in timers that can replace any timers that have been removed.
- If this configuration is being used with a dual-element cylinder, then connect Heater 2 to the top element and set priority 2-1. This ensures that the power available from the PV is used to maximise heating of the cylinder top first.

Please note: The LCD heater icon will display HOT when boosting from the economy supply.

Wiring: Pool or Heatpump

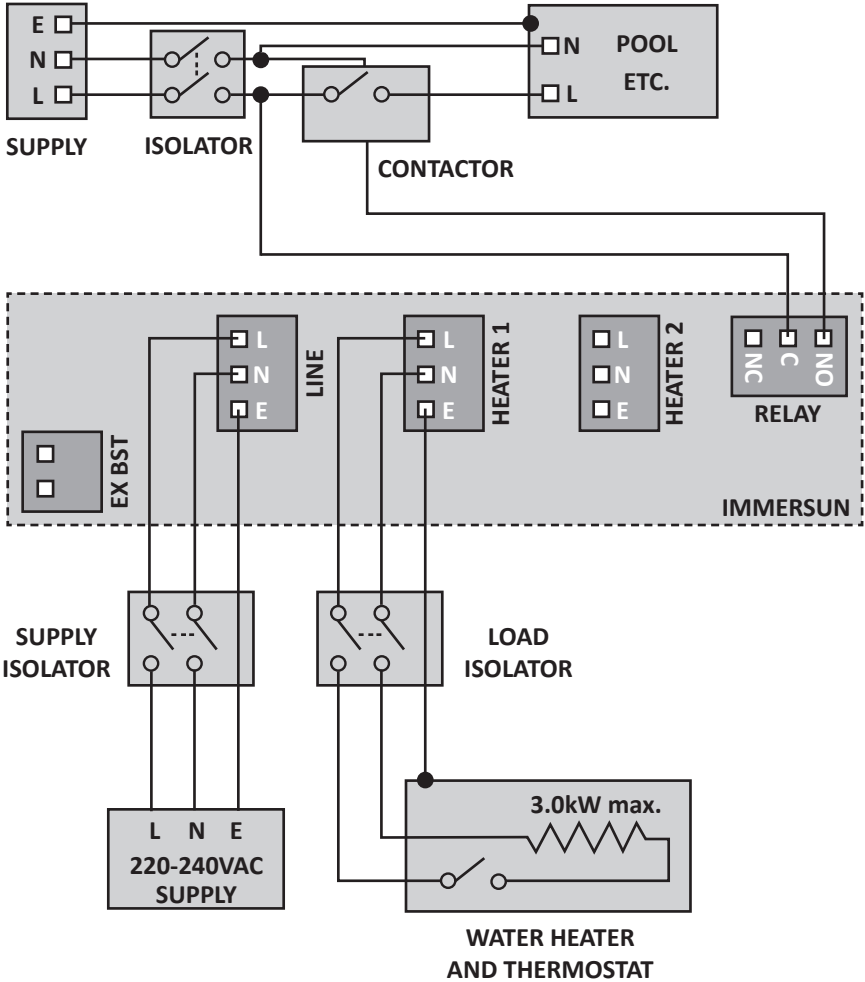



Pool, spa pool, heatpump or other non-resistive load wiring

The heater is heated with surplus PV power until the thermostat opens, the immerSUN will then display HOT. The surplus PV power can then be used for a pool or heatpump or other non-resistive load by using the multifunctional relay.



Important!

- Maximum load: Heater 1, 3.0kW
- Minimum load: Heater 1, 150W
- Recommended cable size: 2.5mm²
- Maximum load, Relay: 16A (non-inductive)



Settings

Heater 1 Type: Set to match the load

Heater 2 Type: None

Heater 3 Type: None

Relay Function: Set to: Export Threshold

External Boost: Not used

Boost Times: Set as required to boost the relay controlled load.
Select "T" in the menu.



Tips and Ideas

- Smaller loads can be connected in parallel as long as the maximum load is not exceeded.
- The immerSUN has built-in timers that can replace any timers that have been removed.
- The External Boost input is free to use if an auxiliary device needs to have some control over the immerSUN.
- If a load greater than 16A needs to be controlled by the relay, then an external contactor must be employed.
- If you are controlling a motor, pump or other inductive load, then an external contactor must be employed.

In this wiring configuration, the **POOL SUPPLY** could be supplied via an RCD, since the circuit is isolated from the immerSUN by way of a contactor.

- To turn the pool or heatpump on when not under a TIMED BOOST, activate a MANUAL BOOST from the front panel.

Error Messages

1

ERROR 1
VOLTAGE BACK-FEED 1
Check:
Heater 1 wiring

VOLTAGE BACK-FEED
During self-test, the unit has detected unexpected voltage at the Heater 1 output, this could damage the unit.
THE UNIT SHOULD NEVER BE BACK-FED
Check: The wiring must be incorrect, check wiring.

2

ERROR 2
VOLTAGE BACK-FEED 2
Check:
Heater 2 wiring

VOLTAGE BACK-FEED
During self-test, the unit has detected unexpected voltage at the Heater 2 output, this could damage the unit.
THE UNIT SHOULD NEVER BE BACK-FED
Check: The wiring must be incorrect, check wiring.

3

ERROR 3
HEATER NOT DETECTED
Check:
Heater is ON
Thermostat is ON

HEATER NOT DETECTED
During setup, the unit did not detect any current being drawn from Heater 1. To get through setup, Heater 1 MUST be connected and functional.
Check: The heater is not isolated, the thermostat is closed (e.g. the water is not already hot), the heater is not faulty.
Test: The heater can be tested by measuring the L – N resistance, it should be between 16Ω and 350Ω.
Note: The immerSUN MUST BE OFF for this test.

4

ERROR 4
SENSOR ERROR
Check:
Sensor wiring
Sensor location

SENSOR ERROR
The sensor is giving unusual readings.
Check: The sensor is properly located and clamped around the correct cable, the sensor is wired to the CT terminals.
Test: The sensor can be checked by measuring the resistance across the CT terminals, it should be about 200Ω when not plugged in. When connected to the unit, it should be approximately 38Ω.
Note: The sensor may need to be unclipped from the cable before testing.

5

ERROR 5
INTERNAL FAULT
Contact installer

INTERNAL FAULT
There is a problem with the unit. Contact technical support or the installer.
Check: None possible
Test: None possible.

6

ERROR 6
UNIT OVERHEAT

Check:
Ventilation

UNIT OVERHEAT
The unit is overheating.
Check: There is adequate ventilation and that the vents are not blocked.

7

ERROR 7
OUTPUT OVERLOAD

Check:
Heater rating

OUTPUT OVERLOAD
The output current is too high. The heater connected is too large.
Check: The heater KW rating, it should be less than 3.0kW and more than 150W.

8

ERROR 8
LOAD SHORT-CIRCUIT

Check:
Heater

LOAD SHORT-CIRCUIT
One of the heater outputs is shorted. The heater is faulty.
Check: The heater for faults.
Test: The heater can be tested by measuring the L – N resistance, it should be between 16Ω and 350Ω
Note: The unit MUST BE OFF for this test.

9

ERROR 9
UNDER VOLTAGE

UNDER VOLTAGE
The supply voltage is too low.
Test: The supply should be between 215V and 259V.

10

ERROR 10
OVER VOLTAGE

OVER VOLTAGE
The supply voltage is too high.
Test: The supply should be between 215V and 259V.

13

ERROR 13
FAN FAULT

FAN FAULT
The fan is faulty.
Note: Please contact your installer.

Technical Specifications

Model Number: T1060
Supply Voltage: 220 - 240V AC @ 50Hz
MCB/Fuse Rating: 16A / 13A
Input Current (max): 13A

Load Capacity: 150W - 3000W
Output Voltage: 0V - Supply Voltage

Relay Contact Rating: 16A 250V AC
External Boost Input: 24 - 275V AC (<1W)
Sensor Current (max): 100A

Ambient Temperature: -20 to +35°C

Standby Consumption: 3.5W
Efficiency: 98%
Power Factor: 1.0

Power Control Method: PWM
Control Resolution: 0.33%
1% Response Time: 1 second
Measurement Accuracy: +/- 1%

Dimensions: 235 x 152 x 72mm
Unit Weight: 1.7 kg
Package Weight: 2.4 kg
IP Classification: IP20

immerLINK radio linking frequency: 868MHz

Compliance:
60335:1 Safety of household electrical appliances.
EN 61000-6-3:2007+A1:2011 Electromagnetic compatibility (EMC)- Generic standards.
EN 61000-3-2:2006+A1:2009+A2:2009 Limits for harmonic current emissions.
EN 61000-3-3:2008 Limitation of voltage changes, voltage fluctuations and flicker.

Country of Manufacture: UK

Site Installation Details

Installed By:

Installation Date:

PV Panel Type and Size:

PV Panel Quantity, String 1:

PV Panel Quantity, String 2:

Inverter Type/Model No.:

Inverter Size:

Inverter Serial No:

ImmerSUN Controller Details

Serial No:

Heater 1:

Heater 2:

Multifunction Relay:

Notes

immerSUN[®]
P o w e r e d b y



enaSOLAR

Version 4.0
30 March 2015

EnaSolar Limited

66 Treffers Road Christchurch 8042 New Zealand
Telephone 64 3 366 4550 Facsimile 64 3 366 0884