



FOBO Xtra

User Manual

Version 1.0

(for iOS7.1 and Android 4.30 & above)



Contents

- 1 Introduction**
- 2 About FOBO Xtra**
- 3 Importance of tire care**
- 4 Product Description of FOBO Xtra**
 - 4.1 Tire Sensor unit**
 - 4.2 Sensor lock nuts**
- 5 Using FOBO Xtra**
 - 5.1 Installing FOBO Tire App**
 - 5.2 Editing Tire Setting**
 - 5.3 Enable Gauge Pressure**
 - 5.4 Disable Alert**
 - 5.5 Disable Sensor and Replace New Sensor**
 - 5.6 Release Sensor**
 - 5.7 Transfer FOBO Xtra to another user**
 - 5.8 Clear Memory and Grey out Reading Box**
- 6 FOBO Xtra Alert Messages**
- 7 Replacing Battery**
- 8 Trouble Shooting Guide**
- 9 FOBO Xtra Specifications**
- 10 Warning**
- 11 Regulatory Information**
- 12 Intellectual Properties**
- 13 Limited Warranty and Disclaimer**



1 Introduction

FOBO Xtra serves as additional sensor that can be added to the default 4-sensors system of both FOBO Tire and FOBO Tire Plus, which many of you are currently using. These additional sensors can be used for monitoring of spare tires, air suspensions for certain vehicles, trailers, caravan and the likes, which require more than the usual 4 tires pressure monitoring. Any alert from the Xtra sensors will go directly to the paired phone, within the Bluetooth zone. Bluetooth Smart is a very low power wireless technology that could operate on a single coin cell battery for up to two years (**NOTE: Battery life may vary according to usage and climatic temperature. Operating under extreme cold may drastically reduce battery life.**)

Please ensure that your smartphone has Bluetooth Smart Ready (Bluetooth 4.0) capability in order to use FOBO Xtra. FOBO Xtra has been integrated into existing FOBO Tire App. Currently FOBO Tire App works best with iOS7.1 and Android 4.30 and above.

Before starting to use FOBO Xtra, please download the latest free FOBO Tire App to your smartphone from Google PlayStore or Apple AppStore.

FOBO Xtra is a product designed and produced by Salutica Allied Solutions Sdn. Bhd. ("Salutica"), a Malaysian company with its address at No. 3, Jalan Zarib 6, Kawasan Perindustrian Zarib, 31500 Lahat, Ipoh, Perak, Malaysia.

2 About FOBO Xtra

Some drivers have encountered situations where they need to change a flat tire only to realize that the spare tire in their vehicle is flat as well. FOBO Xtra serves as additional sensor that can be added to the default 4-sensors system of both FOBO Tire and FOBO Tire Plus. Users must have either FOBO Tire or FOBO Tire Plus installed in their vehicles before they can use FOBO Xtra. Users can add a maximum of 12 FOBO Xtra sensors to the FOBO Tire App. These additional sensors can be used for non-stop around the clock monitoring of spare tires, air suspensions for certain vehicles, trailers, caravan and the likes, which require more than the usual 4 tires pressure monitoring. FOBO Xtra reads up to a max pressure of 600kPa or 87 psi. FOBO Xtra will appear in an 'Xtra Tire' page to show the additional paired sensors, with conspicuous display and individually editable, to suit the various needs of demanding users. The Xtra sensor will not be linked to the InCar unit, and can monitor pressure from 5-87 psi. This gives users full flexibility in deciding how they want to use the Xtras without jeopardizing the default InCar system that will continue to monitor the main vehicle. Any alert from the Xtras will go directly to the paired phone, within the Bluetooth zone.

With FOBO Xtra, you will get an alert as soon as the tire pressure drops below a certain pre-set level and as long as your smartphone is within the Bluetooth range (~30m). This alert gives you time to get the deflated tire fixed before you need to use your vehicle.



The FOBO Xtra system consists of Xtra tire sensors, and the FOBO Tire App. It requires pre-installed either FOBO Tire or FOBO Tire Plus system in the vehicle, a smartphone and the FOBO Tire App for installation.

Replace your tire valve caps with the FOBO Xtra tire sensors and pair them according to the App's simple on-screen instruction. **NOTE: Under certain conditions the signals from FOBO Xtra sensors may be blocked by surrounding objects or structures. If this occurs, please move around the vehicle in order to capture signals from the Xtra tire sensors.**

The sensors will measure tire pressure of each tire and transmit via Bluetooth to your smartphone. In the event of a problem with your tire pressure or temperature, the FOBO Tire App on your smartphone will alert you.

DISCLAIMER: FOBO XTRA IS NOT A DEVICE THAT PREVENTS ACCIDENTS. IT IS ALSO NOT A DEVICE THAT PREVENTS TIRES FROM BECOMING DEFLATED OR OVERINFLATED. FOBO XTRA IS NOT A SUBSTITUTE FOR SAFE TIRE MAINTENANCE PRACTICES. PLEASE CONTINUE TO TAKE PRECAUTIONARY MEASURES WHILE DRIVING AND TAKE FULL RESPONSIBILITY OF YOUR VEHICLE'S TIRE CONDITION TO ENSURE SAFETY WHILE DRIVING. YOU SHOULD CONTINUE TO PRACTICE PROPER TIRE CARE AND SCHEDULED TIRE MAINTENANCE.

3 Importance of Tire Care

It is extremely important to ensure vehicle tires are properly inflated for safety while driving. However, many drivers tend to neglect proper tire care and maintenance. The vehicle tires are the only contact points between the vehicle and the road. The weight of the vehicle and passengers are supported by the air pressure inside the tires. Improperly inflated vehicle tires may cause serious accidents on the road.

When tires are underinflated, the additional rolling resistance may cause build-up of heat which may lead to the de-lamination of the tire materials as well as damage to the tire's sidewall thus increasing the chances of a tire blow-out. Underinflated tires will also cause accelerated wear on the tire shoulders thereby causing uneven tire wear. Gas mileage will also be affected due to additional rolling resistance when driving with underinflated tires. You would also experience a significant loss of steering precision and cornering stability. Significantly under-inflated tires will also be less effective in resisting hydroplaning.

On the other hand, an overinflated tire will cause accelerated wear on the center portion of the tire resulting in uneven tire wear. It would also result in a harsher ride and makes the tire more susceptible to damage when going over potholes or debris on the road.

What is the optimum tire pressure? There are a lot of information about this subject in internet forums and web articles. A quick guide for better understanding of tire pressure below:-

- 1) Vehicle manufacturers recommend the optimum tire pressure for their vehicle models. The information is usually available on a sticker at the door jamb (side of the driver's door) or in the owner's manual. For some vehicle models, the information sticker may be on the trunk lid or on the fuel door. Vehicle manufacturers usually recommend different tire pressure for front and rear tires. This pressure is usually recommended for comfort driving and optimum performance of the vehicle. It is not advisable to go below this recommended pressure level.
- 2) The vehicle manufacturer recommended tire pressure is "cold pressure". When you drive your vehicle to the gas station, the friction on the road will heat up your vehicle tires within a few minutes. Typically there will be 1psi (7kPa) increase in air pressure for every 10°C (50 °F) increase in tire temperature. It is advisable to inflate the tire pressure with this compensated pressure above the recommended pressure.
- 3) Air pressure in tires is affected by changes in temperature. Check and adjust your tire pressure whenever there is a drastic change in environment temperature, eg. change of season.
- 4) A tire will normally lose its pressure through natural causes unless accelerated by a puncture, faulty valve or damaged wheels. It is advisable to change the tire valves or at least check the valves condition every time you change a new set of tires. Under normal condition, a set of tires could deflate at a rate of up to 2psi per month. It is good practice to check your tire pressure regularly and top up to the optimum pressure.
- 5) Every vehicle tire has a maximum inflation pressure. It is not advisable to inflate to the maximum inflation pressure of the tire. Follow the vehicle manufacturer's recommended tire pressure instead.

4 Product Description of FOBO Xtra

4.1 Tire Sensor Unit

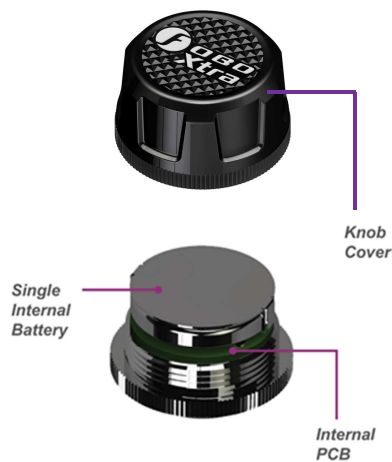

- Knob cover** - waterproof cover. Please ensure the red silicon ring is intact to prevent water from getting into electronics compartment.
- Single internal battery** - CR2032 coin cell battery. When replacing battery, please ensure the “+” sign of the battery is facing up, away from PCB.
- Internal PCB** - internal electronics circuit

FOBO Xtra sensor units are designed to be robust and operate reliably 24x7 to provide tire information around the clock. It is designed to be water proof (IP57) and by our special use of custom engineering plastics, it will be able to withstand road salts or other common automotive chemicals (petrol, engine oil, vehicle wash shampoo, etc).

Our designers have designed the sensors to ensure that there is no air leakage as it replaces the tire’s original valve cap. There is no need to screw on the sensor extremely tight. Apply a reasonable hand twist force to ensure the sensor is securely installed and should be able to be removed by hand with ease.



Note that the sensor position is fixed during installation. When installing the sensors, please follow the on-screen prompt of the FOBO Tire App. Do not screw on the tire sensors until instructed by the FOBO Tire App.

A missing or damaged tire sensor can be replaced easily through the FOBO Tire App. You will need to purchase a replacement sensor which you can do so online at www.my-fobo.com. To replace the sensor, first select 'Disable/Install Sensor' on the FOBO Tire App on your vehicle status settings and the App will prompt you to tap on the tire position that you want to replace for 5 seconds. The box will then show "Disabled". Then, select 'Disable/Install Sensor' again and tap on the same box and the App will prompt you to install the replacement sensor. Follow the on-screen instruction and the replacement sensor will be paired and ready to use.

4.2 Sensor Lock nuts

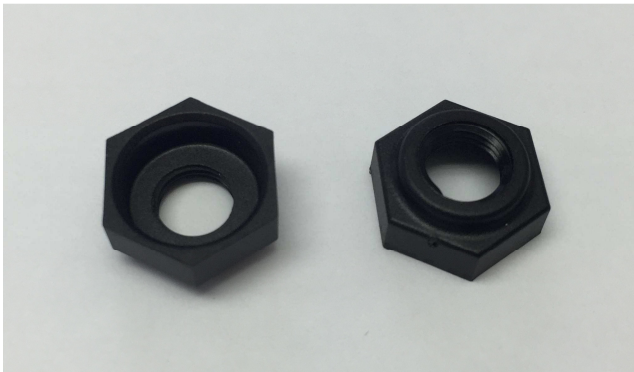

FOBO Xtra sensors are tied to a FOBO account after installation. They are not reusable or transferable without the owner releasing them from his/her FOBO account. This is a theft deterrent feature to discourage theft.

As an additional anti-theft feature, all FOBO Xtra package comes with lock-nuts. FOBO Xtra's functionality is not affected if you do not use the lock-nuts.

The lock nuts are made of custom engineering plastics that can withstand road salts and common automotive chemicals (gasoline, engine oil, vehicle wash shampoo, etc).

In order to use the lock nuts, you must first install the lock nut to the tire valve (with the bump facing tire rim). Screw in the lock nut all the way down and ensure that there is still a **minimum of 5 thread count** on the tire valve for the sensor unit to be screwed on. If there is insufficient thread for the tire sensor, it may lead to air leakage. A solution for this would be to change the tire valve to one with a longer



thread. Next, screw in the tire sensor unit until it is reasonably tight. Then use your finger to unscrew the lock nut outwards (i.e. anti-clockwise) until it pushes against the bottom of the sensor unit. Use the wrench to tighten the lock nut. The resultant friction force will make it difficult to remove the sensor unit without loosening the lock nut. For rubber valves, hold the valve stem with one hand and tighten the lock nut with the wrench on another hand. This is to avoid the rubber valve from twisting making it unable to tighten the lock nut.

WARNING: Do not apply too much force to tighten the lock-nut. You may face difficulty to loosen the lock nut later on especially for rubber valves that typically doesn't stay firm on the tire rims.

NOTE: If your tire valve is too short, you shouldn't use the lock nut as this will block the sensors from being completely screwed on the tire valve and causes air leak. Our sensors are designed to work on a tire valve with a minimum of 5 thread counts.

Step by step diagram to use FOBO Xtra Lock Nut and wrench

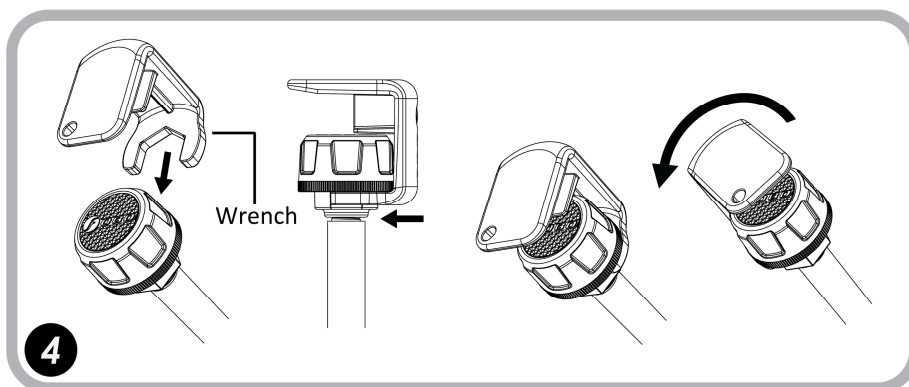
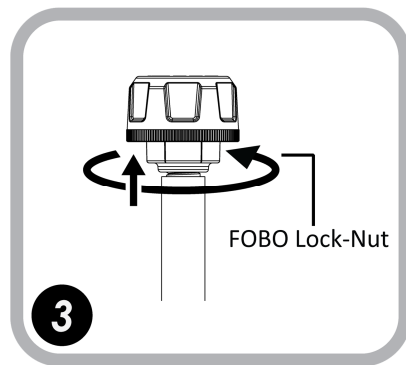
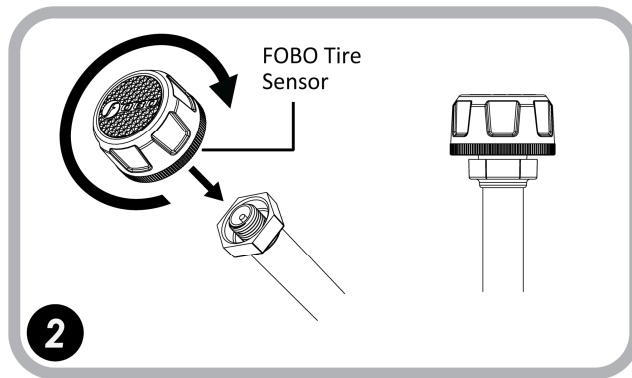
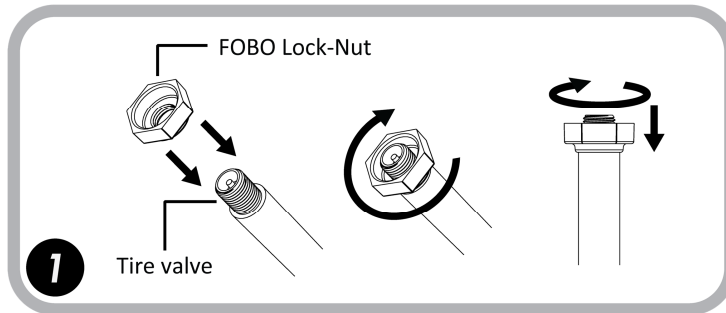



5 Using FOBO Xtra

5.1 Installing FOBO Xtra

You must have either FOBO Tire or FOBO Tire Plus installed in your vehicle before you can use FOBO Xtra. Make sure your FOBO Tire App is the latest version with FOBO Xtra feature incorporated in it. Otherwise, you need to download the latest FOBO Tire App from AppStore or GooglePlay onto your smartphone. Follow the steps below to install your FOBO Xtra:-

Step : Launch the FOBO Tire App

- Click on your vehicle icon
- Click on the “Xtra Tires” page
- Click on “Add Xtra” at the top right
- An installation box will emerge and prompt you to enter a name for the tire and its recommended tire pressure
- Click “OK”
- Enter the tire name and the recommended tire pressure and click “Done”
- Click “Done” at the top right.
- A “Sensor Install” box will emerge instructing you on the Xtra sensor installation process.
- Screw the Xtra sensor onto the valve stem of the tire, touch the sensor with your phone and click “OK”.
- Once paired the tire’s name and pressure/temperature readings will appear on the phone.

IMPORTANT: FOBO Xtra is locked to your FOBO account as an anti-theft deterrent. Stolen sensors cannot be used by anyone else other than the FOBO account owner.

Location service is required to be enabled for the FOBO Tire App (FOBO Xtra does not use the GPS function to track your location). The location service on the iOS/Android system has other functionality that the FOBO Tire App uses to operate properly. It will ensure FOBO Xtra functions as designed, mainly for alert functions, and also for the gauge pressure feature to work as required by users living at high altitudes. FOBO Xtra is designed to be a low energy system and does not drain your smartphone battery excessively.

By submitting your information to sign up a new user account, you acknowledge your acceptance to the terms and conditions of our Software Licensing Agreement and Privacy Policy.



NOTE:

Do not install the sensors to the vehicle tire valves until prompted by the FOBO Tire App's on screen instruction.

To minimize the risk of potential electrostatic discharge(ESD) attack, please hold the tire rim when screwing the sensors on to the tire valves. ESD may cause damage to the sensor or impair its function.

Installing FOBO Xtra sets on more than one vehicle which are closely parked may cause cross interference to the Bluetooth signals. Please install FOBO Xtra on one vehicle at a time.

The Min value cannot be set higher than the selected Recommended value while the Max value cannot be set lower than the selected Recommended value.

5.2 Edit Tire Setting

Follow the steps below to edit tire setting for tire name and pressure:-

- 1) Go to Xtra Tire page and click on the Xtra Tire box of the Xtra sensor to be edited
- 2) Select "Edit Tire Setting"
- 3) Key in the new name or new pressure setting
- 4) Click "Done" located at middle left of screen
- 5) A "Warning" box will appear advising on the need to sync to apply the new setting
- 6) Click "OK" on the "Warning" box
- 7) Click "Done" on the top right
- 8) A "Not Sync" box will appear
- 9) Click on the "Not Sync" box and a menu will appear
- 10) Select "Sensor Sync"
- 11) An instruction box will appear
- 12) Follow the instruction by removing the Xtra sensor and wait for 8 sec and then screw it back to the valve stem
- 13) Hold the phone close to the Xtra sensor and click "OK" on the instruction box
- 14) Click "OK" on the "Sync Completed" box

CAUTION: Do not change setting when you are away from your Xtra sensor.

5.3 Enable Gauge Pressure

Gauge pressure feature is required by users living at high altitudes. Click on “Enable Gauge Pressure” to enable this feature.

5.4 Disable Alert

If you want to disable the alert of a particular Xtra sensor just click on the “Xtra Tires” page, select the Xtra sensor to be disabled and select “Disable Alert”.

5.5 Disable Sensor and Replace New Sensor

You may want to disable a Xtra sensor in the App due to a physically missing sensor or damaged sensor and to install a replacement sensor. Disabling the missing or damaged sensor in the App will stop the alert for missing sensor alerts.

To disable a tire sensor:-

1. Select the Xtra sensor to be disabled and click “Disable Sensor”
2. “Disabled” will appear in the Xtra sensor box

To install a replacement Xtra sensor:-

1. Click on the “Disabled” box
2. Select “Install Sensor” from the menu
3. A “Sensor Install” box will appear
4. Follow the instruction and click “OK”
5. Click “OK” on the “Installation Completed” box

NOTE:

1. **You can only install a replacement sensor after the tire position has been “Disabled”. You can purchase replacement sensors online from www.my-fobo.com.**
2. **Disabled Xtra sensor cannot be reused as a Xtra sensor for another car even though this car is under the same account.**



5.6 Release Sensor

To release FOBO Xtra, do the following steps:-

1. Select the Xtra sensor to be released.
2. Select “Release Sensor” and follow the instruction on the screen.
3. Click “OK” once release is completed.

NOTE:

1. **Do not delete your Xtra profile before releasing the sensors. If you have accidentally done so, re-install the sensors to the same FOBO account and follow the release procedure above to properly release the sensors.**

5.7 Transfer FOBO Xtra to another user

Before passing on your FOBO Xtra unit to another user, you will have to release the FOBO Xtra sensor from your FOBO account. Follow the instructions at Section 5.6 above to release your FOBO Xtra sensor.

5.8 Clear Memory & Grey Out Reading Box

The most recent tire pressure reading will be displayed in the Xtra Tires page whenever the phone and FOBO Xtra are within Bluetooth connection range. These pressure readings will always be displayed as memory until the phone receives the next pressure reading update from FOBO Xtra sensors.

User can clear the memory of tire pressure readings by selecting Clear Memory option in the Xtra setting screen. The relevant Xtra box in the Xtra Tire page will be cleared and display “--” until the phone receives signal from FOBO Xtra sensors.

The background of the pressure reading box will turn grey when your phone and sensors are out of Bluetooth connectivity zone (10-20m). The readings shown are the last memory. The background of the reading box will return to white when the Bluetooth connectivity is restored. It takes 10-15 sec for each sensor to restore the signal, and depending on the timing, one may be grey and one may be white. Eventually all the boxes should be white before you start your journey.

This function is normally used for trouble shooting purposes. FOBO Xtra will always update the reading displayed on the App automatically with the latest reading. You do not need to select ‘Clear Memory’ to get the latest reading.



NOTE: If the grey boxes do not turn white when you are in the Bluetooth connectivity zone with the sensors, it may indicate a sensor problem. Please check if the sensor is missing, out of battery, or defective.

6 FOBO Xtra Alert Messages

You will get the following alert messages on your smartphone during the operation of FOBO Xtra under different breached conditions. When you receive an alert, please find a safe location to stop your bike and check the alert messages on the smartphone.

6.1 Pressure below preset limit

You will receive an alert when the tire pressure drops below 8%(first level alert – L1) or 15% (second level alert – L2) or 25%(third level alert – L3) of the recommended pressure that you have set or at and below 30kPa(0.3bar/4.35psi). You can change this lower limit as shown in Section 5.2. For fuel economy and optimum tire performance, it is recommended to maintain this 8% range so that you can keep your tires inflated optimally. If you find the reminder is too frequent, you may want to check your tire for any leakage. Note that drastic temperature drop may also cause tire pressure drop. Please check your tire pressure and re-inflate during change of seasons.

6.2 Pressure above preset limit

You will receive an alert when the tire pressure increases beyond 25%(first level alert – L1) or 35% (second level alert – L2) or 45%(third level alert – L3) of the recommended pressure that you have set or at and below 600kPa (6bar/87psi). You can change this upper limit as shown in Section 5.2. For optimum tire performance and grip, you should not overinflate your vehicle tires. Note that the tire pressure will naturally increase as the vehicle tires heat up due to friction while driving. However, you should check your tire in the event of an abnormal rise in the tire pressure.

6.3 Sensor battery level low

You will receive this alert when the sensor battery level drops to a certain level. Please change the battery immediately after you receive this alert. You will continue to receive this alert every time you start moving your bike until the battery is changed.

6.4 Pressure too low

You will receive this alert when the tire pressure drops below 25% of the recommended pressure that you have set or below 30kPa(0.3bar/4.35psi), whichever is higher. This is third level(L3) alert which indicates that the tire pressure is critically low.

NOTE: IT IS DANGEROUS TO DRIVE WITH LOW TIRE PRESSURE AND IT MAY LEAD TO A BLOW-OUT. PLEASE STOP THE VEHICLE AND HAVE THE TIRE CHECKED WHEN YOU RECEIVE THIS ALERT.

6.5 Pressure too high

You will receive this alert when the tire pressure is 45%(third level) above the recommended pressure that you have set or beyond 600kPa(6bar/87psi), whichever is lower. This is third level(L3) alert which indicates that the tire pressure is critically high.

NOTE: THIS IS AN ABNORMAL RISE IN THE TIRE PRESSURE. PLEASE STOP THE VEHICLE AND HAVE THE TIRE CHECKED WHEN YOU RECEIVE THIS ALERT.

6.6 Temperature too high

You will receive this alert when the temperature detected exceeds 65°C/149°F. Note that the temperature inside the tire may be higher than the temperature detected by FOBO Xtra sensors due to the air cooling effect on the tire valve when the vehicle is moving. It is extremely dangerous to ride when you get this alert message.

WARNING: WHEN YOU RECEIVE THIS ALERT, PLEASE STOP YOUR VEHICLE IMMEDIATELY AND CHECK THE TIRE!

Summary of Alerts:

Alarm Level	Trigger Point when threshold breached	Remarks	App Alerts
1 st Level (L1)	8% below 25% above	Soft alerts	App will alert once and stop. When the user goes away from vehicle for 15min and return, the alert will recur for once and stop, so on and so forth. The alert will be triggered even when the App is in the background.
2 nd Level	15% below	Emergency	App will alert every 90 seconds until



(L2)	35% above	alerts	the user navigates to the Status page. The alert will then stop but will recur at 90sec interval after the user has left the vehicle for 15 minutes and return, even when the App is in background
3rd Level (L3)	25% below or at 30kPa and below 45% above or touching 600kPa	Emergency alerts	App will alert every 90 seconds until the user navigates to the Status page. The alert will then stop , and will recur at 90sec interval after the user has left the vehicle for 15 minutes and return, even when the App is in background
	Missing Sensor	Same as L2	Same as L2
	High Temperature (above 65 ⁰ C)	Same as L2	Same as L2
	Battery Low	Same as L1	Same as L1

WARNING: FOBO XTRA IS A MONITORING DEVICE TO ALERTS THE USER WHEN IT DETECTS SIGNALS THAT IS OUT OF PRE-SET CONDITIONS BASED ON THE SETTING BY THE USER. THE USER OR DRIVER IS SOLELY RESPONSIBLE TO FIND OUT THE ACTUAL CONDITION OF THE TIRE AND TO ENSURE PROPER TIRE MAINTENANCE. FOBO TIRE IS NOT RESPONSIBLE FOR WRONG DIAGNOSTICS OR FALSE ALERTS THAT MAY CAUSE INCONVENIENCE.

7 Replacing Battery

The coin cell battery (CR2032) used in the FOBO Xtra sensors could last up to two years based on normal operating condition. Operating in extreme cold or hot temperatures may reduce battery operating life for the tire sensors.

You will receive an alert on the smartphone when the sensor battery levels are low. You will be alerted every time you start to drive your vehicle until the battery is replaced. It is advisable to change the battery once you receive this battery alert to ensure proper performance of FOBO Xtra. Do not wait until the battery is fully drained as it will cause FOBO Xtra to stop working properly.



To replace the battery of sensor unit, unscrew the top cover. Be careful not to damage the rubber gasket as it may affect water resistance of the sensor unit. Ensure the battery (CR2032) is inserted with the “+” sign facing up, away from the PCB.

WARNING: RE-USING OLD BATTERIES MAY DAMAGE THE ELECTRONICS.

8 Trouble Shooting Guide

- Could not sign up a new FOBO account (did not receive activation e-mail)
 - Check the e-mail address entry is typed correctly
 - Check the Spam mailbox, in case the e-mail was filtered by the e-mail server
 - Check the smartphone is connected to internet and able to receive e-mail

- Could not sign up a new FOBO account (received activation e-mail)
 - Make sure to click on the “Activation” link of the latest e-mail, in case there are multiple authentication e-mails
 - You should be directed to web page that clearly displayed “FOBO account is activated”.

- Unable to Login after signing up to FOBO App
 - Make sure your e-mail address is typed correctly
 - A verification mail will be sent to your e-mail address
 - Follow the instruction in the mail to activate your account before you can Login
 - Check if internet connection is available on your smartphone

- Unable to pair FOBO Xtra sensors
 - Make sure the sensor is screwed onto a tire valve with pressure above 100kPa
 - Try unscrew the sensor from tire valve, screw it back and try again
 - Make sure the battery is installed correctly with battery “+” on top.
 - Make sure your smartphone has Bluetooth 4.0 (Smart Ready) capability.
NOTE: BLUETOOTH 2.0 OR 3.0 WILL NOT WORK WITH THIS DEVICE.
 - Try to reset the Bluetooth manager of your smartphone (for iOS: Settings-> Bluetooth-> OFF->ON). At times the Bluetooth manager may be disrupted which may require manual reset.
 - Try to do a hard reset on the phone.

9 FOBO Xtra Specifications

- **Bluetooth:** v4.0
- **Supported profiles:** GAP, GATT attributes, Device Information Service, Proximity Reporter, Battery Service
- **Transmit Conducted Power:** +4.0dBm (sensor)
- **Receiver Sensitivity:** -93dBm@0.1%BER
- **Antenna Return Loss:** -12dB
- **Operating Frequency:** 2.4 GHz
- **Weight:** ~11.5g (sensor – with battery)
- **Sensor Dimension H x D:** 15mm x 26mm
- **Maximum Pressure:** 600kPa (87psi)
- **Battery Type:** CR2032 (sensor) Operating life up to two years. (**NOTE: The battery operating life varies according to usage and climate temperature**)
- **Operating Temperature:** -40°C to 85°C(sensor)
- **ESD:** 8kV air, 4kV direct contact
- **Operating Humidity:** up to 90% non condensing at 40°C
- **Dust and Water Proof:** IEC60529 compliant to IP57(sensor)
- **Sensor structural threshold:** 350N ball pressure intensity test
- **Mechanical & Environmental Reliability Testing Standards:** IEC 60068-2-2, IEC 60068-2-1, ISO 21750, IEC 60068-2-29, IEC 60068-2-5, IEC 60068-2-32, ISO 15184, ISO 2409

10 Warning

- Take note that FOBO Xtra is not meant to function as anti-accident or anti-injury device. FOBO Xtra is not a substitute for safe tire maintenance practices. Please take full responsibility of your own safety while driving. And continue to send your vehicle for regular tire check and maintenance.
- You shall not use the FOBO Xtra in any unlawful way that violates any laws.
- Avoid exposing the FOBO Xtra sensors to solvent, fire or extreme temperatures.
- FOBO Xtra may fail to function properly if the battery is below optimum level. Replace the battery immediately to continue enjoying full features of FOBO Xtra.



CAUTION

THERE MAY BE A RISK OF EXPLOSION IF BATTERY IS REPLACED BY AN INCORRECT TYPE. DISPOSE ALL USED BATTERIES PROPERLY.

11 Regulatory Information

Federal Communication Commission Interference Statement

This device complies with Part 15 of the FCC Rules. Operation is subject to the following two conditions: (1) This device may not cause harmful interference, and (2) this device must accept any interference received, including interference that may cause undesired operation.

This equipment has been tested and found to comply with the limits for a Class B digital device, pursuant to Part 15 of the FCC Rules. These limits are designed to provide reasonable protection against harmful interference in a residential installation. This equipment generates, uses and can radiate radio frequency energy and, if not installed and used in accordance with the instructions, may cause harmful interference to radio communications. However, there is no guarantee that interference will not occur in a particular installation. If this equipment does cause harmful interference to radio or television reception, which can be determined by turning the equipment off and on, the user is encouraged to try to correct the interference by one of the following measures:

- Reorient or relocate the receiving antenna.
- Increase the separation between the equipment and receiver.
- Connect the equipment into an outlet on a circuit different from that to which the receiver is connected.
- Consult the dealer or an experienced radio/TV technician for help.

FCC Caution: Any changes or modifications not expressly Approved by the party responsible for compliance could void the user's authority to operate this equipment.

This transmitter must not be co-located or operating in conjunction with any other antenna or transmitter.

Radiation Exposure Statement:



This equipment complies with FCC radiation exposure limits set forth for an uncontrolled environment. This equipment should be installed and operated with minimum distance 20cm between the radiator & your body.

Industry Canada statement:

This device complies with RSS-210 of the Industry Canada Rules. Operation is subject to the following two conditions: (1) This device may not cause harmful interference, and (2) this device must accept any interference received, including interference that may cause undesired operation.

Ce dispositif est conforme à la norme CNR-210 d'Industrie Canada Applicable aux Appareils radio exempts de licence. Son fonctionnement est sujet aux deux conditions suivantes: (1) le dispositif ne doit pas produire de brouillage préjudiciable, et (2) ce dispositif doit accepter tout brouillage reçu, y compris un brouillage susceptible de provoquer un fonctionnement indésirable.

Radiation Exposure Statement:

This equipment complies with IC radiation exposure limits set forth for an uncontrolled environment. This equipment should be installed and operated with minimum distance 20cm between the radiator & your body.

Déclaration d'exposition aux radiations:

Cet équipement est conforme aux limites d'exposition aux rayonnements IC établies pour un environnement non contrôlé. Cet équipement doit être installé et utilisé avec un minimum de 20 cm de distance entre la source de rayonnement et votre corps.

European Union Regulatory Conformance

This equipment is CE marked according to the provisions of the R&TTE Directive (99/5/EC) and is in compliance with the essential requirements and other relevant provisions of the Directive 1999/5/EC. This equipment meets the following conformance standards:

EN 300 328, EN62479, EN 301 489-1&17, EN 60950-1

EU Declaration of Conformity

Hereby, Salutica Allied Solutions Sdn. Bhd. declares that this Bluetooth device is in compliance with the essential requirements and other relevant provision of Directive 1999/5/EC.

Caution: Changes or modifications to this **FOBO** device not expressly Approved by the party responsible for compliance could void the user's authority to operate it.

Bluetooth Wireless Compatibility:



This **FOBO** device supports the following Bluetooth wireless protocols and profiles:

- Bluetooth core technology v4.0
- Battery Profile (BAS)
- Proximity (PXP)
- Device Information Service (DIS)

Bluetooth Wireless Interoperability:

This **FOBO** device is designed to be interoperating with all Bluetooth wireless products that support compatible profiles and roles including:

- Bluetooth core technology v4.0
- Bluetooth master and slave roles

NCC Statement 低功率電波輻射性電機管理辦法

第十二條 經型式認證合格之低功率射頻電機，非經許可，公司、商號或使用者均不得擅自變更頻率、加大功率或變更原設計之特性及功能。

第十四條 低功率射頻電機之使用不得影響飛航安全及干擾合法通信；經發現有干擾現象時，應立即停用，並改善至無干擾時方得繼續使用。前項合法通信，指依電信法規定作業之無線電通信。低功率射頻電機須忍受合法通信或工業、科學及醫療用電波輻射性電機設備之干擾。

12 Intellectual Properties

- FOBO™ is a trademark of Salutica Allied Solutions Sdn Bhd. All rights reserved.
- FOBO™ Xtra incorporates a few patent pending technologies solely owned by Salutica Allied Solutions Sdn Bhd.
- Bluetooth® is a registered trademark owned by Bluetooth SIG Inc.
- iPhone® is a registered trademark of Apple Inc.

13 Limited Warranty & Disclaimer

13.1 Warranty



FOBO Xtra comes with a 12 months limited warranty. This Limited Warranty does not cover: 1) products purchased from an unauthorized reseller; 2) products purchased through online auctions; 3) products that are operated in combination with software, peripheral or ancillary equipment such as but not limited to batteries, chargers, adapters, headsets, connector cables, and power supplies ("Ancillary Equipment") not furnished or otherwise certified by Salutica for use with the FOBO products or any damage to the FOBO products or ancillary equipment as a result of such use; 4) damage caused by (a) accident, fire, misuse, neglect, unusual physical or electrical stress, or modification; (b) improper or unauthorized installation, wiring, repair, testing or (c) use of the product outside Salutica's published guidelines; 5) instances in which someone other than Salutica (or its authorized service centers) tests, alters, modifies or services the products in any way; 6) products that have (a) serial numbers or date tags that have been removed or altered, or (b) nonconforming or non-FOBO housings or parts; and 7) consumable spare parts and accessories (unless they are found to be non-functional or broken upon purchase of product).

In order to obtain any warranty service, you agree to bear all shipping charges of the FOBO Xtra device to Salutica's address.

13.2 Disclaimer

SALUTICA MAKES NO OTHER EXPRESS WARRANTY WHETHER WRITTEN OR ORAL AND SALUTICA EXPRESSLY DISCLAIMS ALL WARRANTIES AND CONDITIONS NOT STATED IN THIS LIMITED WARRANTY. TO THE EXTENT ALLOWED BY THE LOCAL LAW OF JURISDICTIONS OUTSIDE MALAYSIA, SALUTICA DISCLAIMS ALL IMPLIED WARRANTIES OR CONDITIONS, INCLUDING ANY IMPLIED WARRANTIES OF MERCHANTABILITY AND FITNESS FOR A PARTICULAR PURPOSE. FOR ALL TRANSACTIONS OCCURRING IN MALAYSIA, ANY IMPLIED WARRANTY OR CONDITION OF MERCHANTABILITY, SATISFACTORY QUALITY, OR FITNESS FOR A PARTICULAR PURPOSE IS LIMITED TO THE WARRANTY PERIOD AS PROVIDED BY SALUTICA IN THE MATERIALS RECEIVED AT THE TIME OF PURCHASE.

No warranty is made that the software provided by Salutica will meet your requirements or will work in combination with any hardware or Applications software products provided by third parties, that the operation of the software products will be uninterrupted or error free, or that all defects in the software products will be corrected.

13.3 Limitation of Liability

THE MAXIMUM LIABILITY OF SALUTICA UNDER THIS LIMITED WARRANTY IS EXPRESSLY LIMITED TO THE LESSER OF THE PRICE YOU HAVE PAID FOR THE PRODUCT OR THE COST OF REPAIR OR REPLACEMENT OF THAT PRODUCT OR ANY COMPONENT OR PART THAT MALFUNCTION IN CONDITIONS OF NORMAL USE. EXCEPT AS INDICATED ABOVE, IN NO EVENT WILL SALUTICA BE LIABLE FOR ANY DAMAGES CAUSED BY THE FOBO XTRA PRODUCT OR THE FAILURE OF THE PRODUCT TO PERFORM, INCLUDING ANY LOST PROFITS OR SAVINGS OR SPECIAL, INCIDENTAL, OR CONSEQUENTIAL DAMAGES. SALUTICA IS NOT LIABLE FOR ANY CLAIM MADE BY A THIRD PARTY OR MADE BY YOU FOR A THIRD PARTY. THIS LIMITATION OF LIABILITY APPLIES WHETHER DAMAGES ARE SOUGHT, OR A CLAIM MADE, UNDER THIS LIMITED WARRANTY OR AS A TORT CLAIM (INCLUDING NEGLIGENCE AND STRICT PRODUCT LIABILITY), A CONTRACT CLAIM, OR ANY OTHER CLAIM. THIS LIMITATION OF LIABILITY CANNOT BE WAIVED OR AMENDED BY ANY PERSON. THIS LIMITATION OF LIABILITY WILL BE EFFECTIVE EVEN IF YOU HAVE ADVISED SALUTICA OR AN AUTHORIZED REPRESENTATIVE OF SALUTICA OF THE POSSIBILITY OF ANY SUCH DAMAGES. THIS LIMITATION OF LIABILITY, HOWEVER, WILL NOT APPLY TO CLAIMS FOR PERSONAL INJURY.

13.4 What Law Governs This Warranty

THIS LIMITED WARRANTY IS GOVERNED BY AND CONSTRUED UNDER THE LAWS OF MALAYSIA.