

User Guide DT288

Portable telephone
for BusinessPhone 250 and BusinessPhone 50



Welcome to the User Guide for the Portable DT288 phone in the BusinessPhone 250 and BusinessPhone 50 system from Ericsson.

It is a state-of-the-art business communications system. Its alliance of features and facilities effectively improves communications for virtually any kind of organization.

To take full advantage of these advanced features and facilities there is a line of phones, designed for ease of use in every situation. During calls the opposite party's name or number is indicated in the display. Only a selected number of display images, however, are shown in the User Guide for your reference.

Note: *The features described in this user guide are related to version 5.0 of the BusinessPhone 250 and BusinessPhone 50 system. Some might not work in earlier versions of the system and/or might be protected by a hardware dongle that has to be bought separately.*

The DT288 portable telephone is a DECT (Digital Enhanced Cordless Telephony) business cordless telephone and it complies to the Generic Access Profiles (GAP), ensuring that it is compatible with and connectable to DECT products from different manufacturers.

To get the most from your DT288 telephone and this User Guide, we recommend to read the "Important", "Description", "Incoming/Outgoing calls" and "Installation" sections first. The User Guide describes the facilities of the BusinessPhone system and the portable telephone with a factory defaults programming. There may be some differences in the way your phone is programmed. Please consult your system administrator if you need further information.

ERICSSON MAKES NO WARRANTY OF ANY KIND WITH REGARD TO THIS MATERIAL, INCLUDING, BUT NOT LIMITED TO, THE IMPLIED WARRANTIES OF MERCHANTABILITY AND FITNESS FOR A PARTICULAR PURPOSE. Ericsson shall not be liable for errors contained herein nor for incidental or consequential damages in connection with the furnishing, performance or use of this material.

CE 0344 X

This Portable Telephone complies with the requirements of the following European Council Directives:

91/263/EEC concerning telecommunications terminal equipment

73/ 23/EEC concerning electrical safety

89/336/EEC concerning electromagnetic compatibility

Quick Reference Guide and Quick Reference Card

DT288

Portable telephone for BusinessPhone 250 and BusinessPhone 50

Answer calls

Answer: 

Suppress ringing: 

Make calls

Internal calls: *Extension No.* **or**
External No. 

Common abbreviated number: *Abbreviated No.* 

Individual abbreviated number: *** * *** *Abbreviated no. 0-9*

Last external number redial: *** * *** 

You get busy tone or no answer

Automatic call-back: **5** 
Go "off hook" when called back

Camp on: **4** *Stay off hook*

Intrusion: **8**

Inquiry

Ongoing conversation:  Call 3rd party

Conference

Ongoing conversation:  Call 3rd party

 **3** (To establish)

 (To leave)

Transfer

Transfer a call:  Call 3rd party

(Before or after answer)

Tandem configuration

Activate: *** 2 8 #**

Deactivate: **# 2 8 #**

Transfer a call between members:  *Own directory No.*
Go "on hook" to transfer the call

Reminder

Reminder (24 hours): *** 3 2 ***
Reminder time #

Cancel reminder: **# 3 2 #**

DISA and Message check:

Company number

DISA Number

Message system

Password

Account number

Cost on a selected account number: *** 9 *** *Account No. #*

Volume control

Earpiece volume (during call): **▲ or ▼**

Call forwarding

Fixed diversion: *** 2 1 #**
 Internal diversion: *** 2 1 *** *New No. #*

Cancel internal diversion: **# 2 1 #**

Follow me, re-direct from answering extension: *** 2 1 *** *Own No. **
New No. #

Cancel from answering extension: **# 2 1 *** *Own No. #*

Bypass call forwarding: *** 6 0 *** *Ext. No. #*

External diversion: *** 2 2 ***
Program: *** 2 2 ***
Line access code
External No. #

Cancel: **# 2 2 #**

Re-activate: *** 2 2 * #**

Messages

"Call me": **9 #**
 Voice: **9 9** *Speak*
 Play-back: *****
 Re-record: **9** *Speak*
 Send: **#**
 Receive messages: *** 5 9 #**

Information

Enter information (pre-text): *** 2 3 *** *Enter "Info code" and "Completing info" (see below) #*

	Info code	Completing info
Time of return	1.	hour (00-23) minute (00-59)
Date of return	2.	month (01-12) day (01-31)
Lunch	3.	back at, hour minute
Meeting	4.	back at, hour minute
Vacation	5.	back, month day
Illness	6.	back, month day

Individual abbreviated numbers

*** * 0**
*** * 1**
*** * 2**
*** * 3**
*** * 4**
*** * 5**
*** * 6**
*** * 7**
*** * 8**
*** * 9**

Special account numbers for business calls:

Project name Account number

1	<input type="text"/>	→	<input type="text"/>
2	<input type="text"/>	→	<input type="text"/>
3	<input type="text"/>	→	<input type="text"/>
4	<input type="text"/>	→	<input type="text"/>

Table of Contents

	page
Important	6
Description	10
Incoming Calls	15
Outgoing Calls	17
During Calls	20
Call Forwarding	24
Information	30
Internal Messages	33
Mailbox System	36
Abbreviated Numbers	39
Group Facilities	42
Other Useful Facilities	45
Security	50
Least Cost Routing	53
Phone Book	54
Adjustments	62
Glossary	65
Installation	67
Troubleshooting	70
Useful Hints	73
Index	74
Voice Guide	77

EN/LZTBS 102 142 R2B

© Ericsson Austria AG 2001

All rights reserved. No parts of this publication may be reproduced, stored in retrieval system, or transmitted in any form or by any means, electronic, mechanical, photocopying, recording or otherwise, without prior written permission of the publisher.

Important

This sections describes the information that is important to know before you use the portable DT288 and the functions described.

Note: *This User guide describes the supported BusinessPhone 250 and BusinessPhone 50 functions together with the most commonly used telephone specific functions. All telephone specific functions are listed in the menu structure. To find out whether or not a function is described in this guide, see section "Description/Menu structure".*

Coverage area

Your organisations premises is covered by a number of cells which forms the coverage area. You can make and answer calls anywhere within this area, outside the area you will lose contact with the system.

Company coverage:

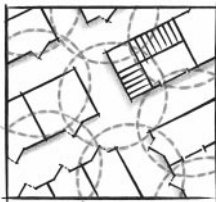

Preparing for use

Before using the DT288 the first time you have to charge and connect the battery, see section "Installation".

Note: *Place the DT288 in the charger and charge it for at least 3 hours before using it the first time.*

PIN code

Your portable is initially provided with a pre-set PIN code, you should change this code to prevent misuse.

Note: *The pre-set PIN code is "0000".*



Access Handset



Access PhoneLock



Select ChangePIN

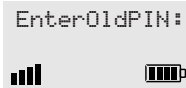

Enter the current 4-digit PIN code and press

You are asked to verify the PIN code.



Repeat the PIN code and press

The new PIN code is now set as the default code.

Note: *If you enter an incorrect PIN code three times in a row, the portable is blocked, see section "IPEI code" to un-block it.*

IPEI code

If your portable is blocked because of an incorrect PIN code, you can un-block it with the IPEI code. The IPEI code is also used by the system administrator to enable network subscription.

Show IPEI code



Access Information



Access ShowIPEI



Enter the current PIN code and press

The 13-digit IPEI code is displayed.

Note: You should write down the IPEI code and store it for future use.



Press to confirm

Un-block the DT288

If the following display message appears, your phone must be un-blocked before you can use it again.

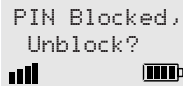

Press



Enter the IPEI code and press



Enter a new PIN code and press

You are asked to verify the PIN code.



Repeat the PIN code and press

The new PIN code is now set as the default code and your phone is un-blocked.

Guidelines

Consider these suggestions and guidelines to keep your telephone in good shape and working properly.

Intrinsic safety

The portable is not specified as intrinsically safe, so do not use it in hazardous areas.

Battery handling

The battery contains environmental polluting material. If damaged, return it to a collecting point.

Note: *Only use the charger that is delivered with your portable to charge the battery.*

Cleaning

Clean the portable only with a soft, water dampened cloth. Using soap or any other cleaning materials may discolour or damage the portable.

Treatment

Do not expose the portable to direct sunlight for long periods. Keep the portable away from excessive heat and moisture.

Network (menu option)

The menu option "Network" should only to be used for administration purposes by Ericsson service staff. Using this menu option may cause a logout from the DECT/GAP network, and no further calls will be possible.

Note: *In case of a logout, the telephone must be logged on again by a service technician.*

Description

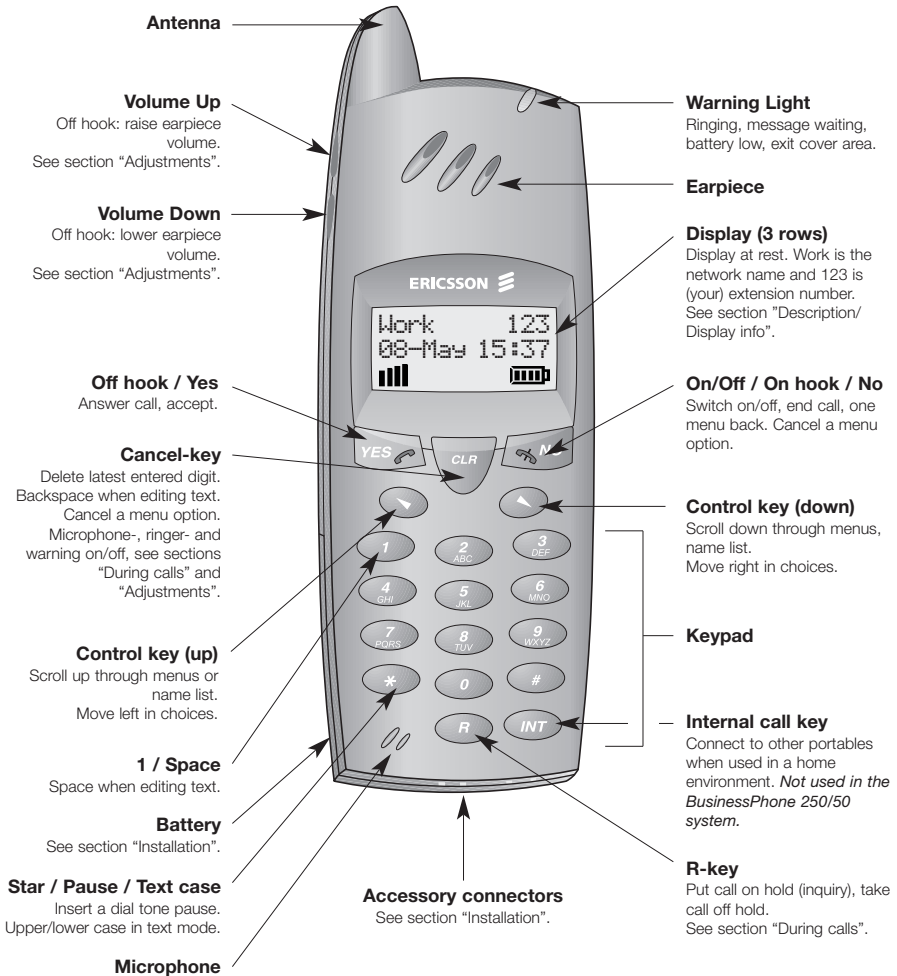

Display info

The display gives you visual feedback on all actions that you perform, and also textual warnings. The upper two rows are text rows (12 possible characters in each row), showing menus that you can access, names and numbers that you edit or dial, your phone id etc. The lower row displays different statuses, visualised by icons.

The DT288 display

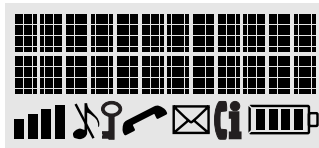

Signs in the text rows



Menu pointer

Shows the menu that can be accessed by pressing yes.



Number to long for display

There are more digits to the left.



Dash

Indicates that a pause is programmed in the telephone number.



Called

Marks a phone number as already called.



Exclamation Mark

Marks an unread entry in an entry list.

Display icons



Signal strength

On when your portable is locked to the system. The bars indicate reception quality. Four bars indicate optimal reception.



Ringer off

Ringling signal muted or microphone off.



Key lock

Keys are locked.



Call

On when your portable is off hook and flashes during ringing.



Message

Message received.



Call info

New unanswered entry in the "WhoCalled" list.



Battery gauge

The battery cells are flashing sequentially when the battery is being charged and is on when charging is completed. Indicates the amount of talk and standby time left.

Note: *An alarm sounds when there is less than 15 minutes calling time left in the battery.*

Additional display features

Depending on which network you are connected to, additional display features are available. For example displaying of date and time. Ask your system administrator if you require additional display features.

Menu structure

The available portable specific telephone and network functions can be accessed via the DT288 menus.

Notes:

- *Since the DT288 telephone can be used in several networks, some functions might not be supported in your network.*
- *Only main functions are included in the list below.*
- *Functions marked with (N) are not described in this guide.*
- * *Applicable only if entries are available.*
- ** *The "Network" menu must only be used by Ericsson service staff, because this option may cause a logout from the DECT/GAP network.*

Functions available on hook

PhoneBook

Find&Call
Store
Find&Edit
DeleteAll

Handset

AutoKeyLock (N)
Babyphone (N)
Alerts
PhoneLock (N)
DirectCall (N)
MasterReset
Language (N)
Display (N)
AutoAnswer (N)

Networks (N) **

SelectNet*
Priority*
Rename*
Delete*
Resubscribe*
Subscribe

Information

WhoCalled*
LastDialled*
LastCall (N)
TotalCalls (N)
ShowIPEI

Functions available off hook

NewCall

Find&Call
WhoCalled*
LastDialled*

DialMode

GoToDTMF
SendPause
DTMF-Long

Switching on/off the portable

Switch on the DT288



Press until the display lights up

If the portable does not switch on or the battery icon starts flashing, the battery is low. Charge the battery.

Note: *If the signal strength icon is off and the message "No network" is displayed you cannot make or answer calls.*

Switch off the DT288

Note: *During calls, you cannot switch off your telephone.*



Press until the display turns blank

Your portable is switched off.

Incoming Calls

A ringing signal indicates an incoming internal- or external call. You can also see who has called you in the who called list.

Answer calls

The ringing type tells you whether the call is an internal, external or call back call and the display indicates an incoming call.

Display example:



Press to answer

If the number is in the phone book, the name is shown instead.

If the portable rings at an inconvenient moment:



Press to suppress the ringing for the moment

Note: Calls can be answered at any time, no matter if you are programming, or keying in a number etc.

End the call



Press

The duration time of the call is shown.

Who called list

Your phone keeps a list of the people who has called you (if supported by the network), the who called list can contain up to ten calls. Whenever there are entries in the who called list, you can view or call back the numbers with the "WhoCalled" option. Each entry in the list is displayed with a number in the upper left corner of the display.

Note: An exclamation mark (!) after an entry number means that you have not read that entry yet. The letter A icon (A) means that you have already called that caller, irrespective of whether you have had contact or not.

The who called list can be permanently stored in the phone book, see section "Phone book".

Note: The who called list will be cleared if the power of your portable is lost.

Call back callers

When your phone is off hook and there are new unanswered calls in the list, you can see the following display message.

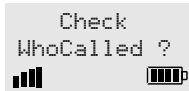

Access WhoCalled



A list of numbers is displayed. If the number is in the phone book, the name is shown instead.



Scroll up or down the name list until you find the number you want to call back



Press to dial the number

The number is removed from the who called memory and stored in the last dialled memory.

Note: You can press the "Cancel-key" instead of "YES" if you want to edit the number before dialling.

Outgoing Calls

Sometimes you make a call but the person is not available. These functions will help you in your attempts to establish contact with the called party.

You can also make a call via the phone book, see section "Phone book".

Make calls

How to make internal and external calls.



Enter the telephone number and press

Your portable will go off hook and dial the number. On the display the duration time of the call is shown.



Press to end the call

Note:

- Correct a wrong entry by pressing the "Cancel key".
- If you decide not to make the call while keying in the number, press "NO" to stop.
- If you receive a call while keying in the number, simply press "YES" to answer.
- You can make your calls faster by using abbreviated numbers or dial-by-name.

Off hook

If you prefer to dial a number off hook:



Press

Dial tone.



Key your number on-line

Last external number redial

When you initiate an external call the system automatically stores all the dialled digits, irrespective of whether the call was successful or not.



Press to redial the last dialled external number

The display will show the dialled number.

Redial number from Last Dialled list

The last ten dialled numbers are memorised by your portable. You can redial one of these numbers by selecting the number from the Last dialled list.



Press and wait until number or name is displayed



Scroll, select number and press to confirm

A number marked with "!" means new number. You can store numbers permanently by adding them to your phone book, see section "Phonebook".

Note: *The Last dialled list will be cleared if the power of your portable is lost.*

Automatic call-back

You call an extension and receive busy tone or get no answer. This can also be used if no external line is free:

5

Press

Verification tone.



Press

You are called back if the extension finishes the ongoing call or the next time the extension finishes a new call. You have to answer within eight seconds otherwise the call-back service is cancelled.

Busy extension

You call an extension and receive busy tone.

Camp-on

You can notify a busy extension of your call by a muted ringing call (if this function is allowed).

4 Press to camp on

Stay off hook. When the called extension replaces the handset it will be called automatically.

***Note:** If you receive the busy tone again, the desired extension does not allow camp-on.*

Intrusion

You can intrude on an ongoing call on a busy extension (if this function is allowed).

8 Press to intrude

Intrusion tone is heard and a three-party call is established. When the called extension replaces the handset and you keep off hook, the called extension will be recalled automatically.

***Note:** If you still hear the busy tone, then your extension does not have the authority to intrude or the desired extension is protected against intrusion.*

During Calls

The BusinessPhone 250 and BusinessPhone 50 system allows you to handle calls in many different ways. You can for instance make an inquiry, transfer the call or create a conference, mute the microphone and ringer, change the dial mode or put the call on hold to perform other tasks.

Transfer and inquiry

You have an ongoing internal or external conversation and you want to transfer the ongoing call.



Press to put the current call on hold

Dial tone.



Call the third party

You can transfer the call before answer or wait for answer.

Note: *Make sure, that you are connected to the desired party. Please read the notes and warnings in section "Useful hints".*



Press to return to your caller

Note: *Sometimes the "R"-key must be pressed twice. Whether you can put internal calls on hold or transfer calls to external lines depends on your PBX. Consult your system administrator.*

or



Press to transfer the call

Transfer to a busy extension

You can even transfer calls to busy extensions. The other party will hear a muted signal (camp-on), and the call will be extended, as soon as the ongoing call is terminated (if camp-on is allowed).

Call-back

You are called back, if you have transferred an external call and the other extension has not answered the call within a certain time. Your telephone will ring again.

Conference

You have an ongoing conversation and you want to establish a telephone conference.



Press

Dial tone.



Call the third party



Press to establish a three party conference

Now you have established a three party conference. To mark the conference, all conference members will hear a periodical conference tone.

Repeat the procedure to include other persons to the conference

In this way, you can include up to six parties in a conversation. How many of them can be external callers depends on the programming of the system.



Press to leave the conference

Dial mode

When calling interactive tele services or controlling telephone answering machines remotely, you must press certain keys (post dial) to give your response. If your portable uses tone dialling (DTMF) to make the call, just press the keys requested by the tele service. If your portable uses pulse dialling, you must manually change to tones, after the call is established:

Note: After you end the call, dialling is always reset to the default method.

Change to tones

When the call is established.



Access DialMode

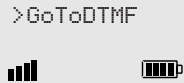

Select GoToDTMF to confirm the change to tones



Press any key to respond

Some services do not work on standard DTMF tones. They require long DTMF tones. If so:



Access DTMF-Longs

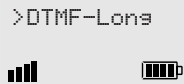

Send a dial tone pause

If you want to send a dial tone pause when the phone is off hook, you can use "DialMode - SendPause".



Select SendPause and press to confirm

A "-" is displayed and the dial tone pause is sent.

Mute microphone

To mute the microphone, during an ongoing conversation:



Press and hold

The caller will not hear the conversation in your room.

or



Press shortly, to turn the microphone off

Short pulse sounds confirm that the microphone is off.



Press again, to turn the microphone on

Note: *It is advised to use this feature instead of putting a call on hold. A call on hold may be diverted to your operator, directly or after some time.*

Mute ringer or warning

If the portable rings or a warning sounds at an inconvenient moment you can temporarily suppress the sound, e.g. when the battery runs low you will be warned by a battery low sound (4 short beeps).



Press shortly to mute the ringing or warning for the moment

The Ringer off icon turns on to indicate that ringing is suppressed.

Note: *When a warning occurs during a call and you want to mute the microphone, the first press always mutes the warning sound. The second press mutes the microphone.*

Call Forwarding

When you are not available to take calls or decide to answer your calls on another extension, it is useful to forward your calls to an alternate answering position.

If you urgently need to talk to someone who has forwarded his calls, the system is also equipped with a bypass function.

Depending on the type of diversion you are also able to record your personal greeting, see section "Personal greeting".

Note: *You can still make calls as usual.*

Diversion on no reply

If you are not available to answer incoming calls (internal or external), your system administrator can program your extension to automatically divert calls to a programmed diversion address (default time: 15 seconds).

Diversion on busy

If your extension is busy and you receive an incoming call (internal or external), your system administrator can program your extension to automatically divert the call to a programmed diversion address.

Fixed diversion

This function directs your calls to a pre-programmed answering position (e.g. secretary).

Activate fixed diversion

*** 2 1 #**

Dial to activate diversion

All calls to your extension are directed to a pre-programmed address. The display shows the actual diversion state.

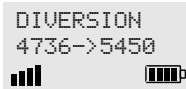

Cancel diversion

2 1

Dial to cancel diversion

Individual diversion

This feature gives you the possibility to divert your calls to internal and external positions, e.g. to any directory number, a colleague's extension, an external number or a common abbreviated number (e.g. your car telephone).

Note: *In order to prevent misuse, individual external diversion can be blocked for your extension, see section "Security".*

Program and activate internal diversion

Divert your calls to an internal position.

*** 2 1 ***

Dial

0000
0000
0000

Enter the new diversion address

#

Press to activate the individual diversion

Verification tone. You can make outgoing calls as usual. A special dial tone reminds you that "Call forwarding" is active. The display shows the actual follow me state.

Note: *An individual internal diversion cannot be activated if an individual external diversion is already activated.*

Cancel internal diversion

2 1

Dial

Individual diversion is cancelled.

Program and activate a new external diversion address

To set a new individual external diversion address:

*** 2 2 ***

Dial

0

Dial the digit(s) for external call access and enter the new external diversion address

A maximum of 24 digits.

#

Press to activate the individual diversion

Verification tone.

Note: *Individual external diversion can also be used via the DISA function, see section "Other useful facilities".*

Cancel external diversion

2 2

Dial

Note: *The programmed diversion address is not removed from the memory, the diversion is just inactive.*

Re-activate external diversion

Divert your calls to an external position.

*** 2 2 * #**

Dial to activate the programmed external diversion

You can make outgoing calls as usual. A special dial tone reminds you that "Call forwarding" is active. The display shows that you have activated an external diversion.

Follow me

To activate Follow me, "Individual Diversion" must be active on your telephone.

Activate follow me

Note: *This procedure has to be executed from the telephone the calls are diverted to.*

*** 2 1 ***

Dial

0000 *
0000
0000

Dial your number and press

0000
0000
0000

Dial the new number to where incoming calls should be diverted

#

Press to activate follow me

Special dial tone.

Cancel follow me

Follow me and individual diversion can also be cancelled from the answering position.

2 1 *

Dial

0000
0000
0000

Dial your number

#

Press to cancel follow me

Dial tone.

Bypass call forwarding

Bypass call forwarding makes it possible to call a specific extension, even if call forwarding is activated on this extension.

*** 6 0 ***

0000
0000
0000

Dial

Enter extension number

#

Press

You will be connected to the specified extension, regardless of which type of call forwarding the called extension has activated.

Information

If you are not in the office for a certain period of time (e.g. meeting, vacation, lunch, illness), this feature allows you to inform your callers why you are absent. External callers will be routed to the operator who also has access to your absent info.

Note: *When you have activated a diversion with a personal greeting, callers will receive this greeting instead of your activated absence information.*

You can inform your callers with:

1) Pre-defined texts

Enter the reason for your absence and the date and time of your return.

2) Voice information

Record a voice message and name your absent information.

Enter information

To store text or voice information.

✖ 2 3 ✖

Dial to enter the information mode

Select "Pre-defined text" or "Voice information"

Pre-defined texts**Enter "Code" and****Enter "Completing info" from the table below**

If you do not know the time of return, just press #.

	Code	Completing info
Time of return	1	hour (00-23) minute (00-59)
Date of return	2	month (01-12) day (01-31)
Lunch	3	back at, hour minute
Meeting	4	back at, hour minute
Vacation	5	back, month day
Illness	6	back, month day

#

Press to enter the information

Internal callers receive the information on the display (or as spoken information to callers without display phone). External callers will be routed to the operator who also has access to your absent info.

*Pre-defined texts example:**Vacation, back June 27*

* 2 3 *

Press

5

Enter code

0 6 2 7

Enter month and day

#

Press

Information active.

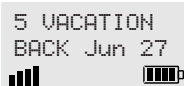

Voice information

- * 2 3 *** **Press to enter information mode**
- 9** **Press and speak**
- *** **Press to play-back and listen to your recording**
- 9** **Press and speak to re-record**
- #** **Press to activate**

Internal callers will hear the information via the handset or the loudspeaker. External callers will be routed to the operator who also has access to your absent info.

Note: *You can dial your own extension number if you want to check your information.*

Erase information, Save information

- # 2 3 #** **Dial to erase info**
- or**
- * 2 3 * #** **Dial to deactivate and save for later use**
Information is passive.

Use saved information

When the information is switched off:

- * 2 3 * #** **Dial to activate saved info**
Information is active.

Internal Messages

You can send a call-back or a voice message when you call an extension and receive busy tone or get no answer. The BusinessPhone 250 and BusinessPhone 50 system is also equipped with a dictaphone function.

Send message

To send a message to an extension when you receive busy tone or get no answer.

Call-back

To send a "call me" message.

9 # **Press to send**

Voice

To send a voice message.

9 9 **Press and speak**

✖ **Press to play-back and listen to your recording**

9 **Press and speak to re-record**

**Press to send**

Check and store received messages

A received message is indicated with a message icon (envelope) in the display (a special dial tone can also be used to indicate a waiting message, if programmed). In addition you can see the number of queued messages in the display.

Received messages are divided into following three categories:

- New messages (not heard or read)
- Heard/Read messages
- Stored messages

Note: *Messages are deleted from the system after a certain time. The time depends on which category the message belongs to. Please ask your system administrator regarding this.*

✖ 5 9

Dial

You can check and store your received messages. Up to 20 messages can be stored.

Voice messages will be heard. "Call me" messages will call the sender automatically (these messages cannot be stored).

Note: *Depending on the configuration, you might be asked for your password before you can retrieve your messages. See section "Security".*

Dictaphone function

If you want to record and retrieve personal voice messages you can use the dictaphone function. A dictaphone message is treated as a normal message. How to retrieve dictaphone messages, see section “Check and store received messages”.

Record message

To start the recording:

*** 5 8 #**

Dial and record your message

The maximum recording time is four minutes and 15 seconds.



RECORDING

Select options below:

Press to play-back

9

Press and speak to re-record

Go “on hook” to stop the recording and save the message

Mailbox System

While you are away from the office, callers can leave messages in your individual mailbox. You are also able to record your personal greeting, see section “Personal greeting”.

Individual mailbox system

If you are not in the office, you can give the service to the caller to leave a message in your mailbox.

Activate

Divert your extension to the mailbox system.

*** 2 1 ***

Dial



Dial the number to the mailbox system

Please ask the system administrator for your defined mailbox number.

#

Press

Deactivate

2 1

Dial

Retrieve messages internally

When the message icon appears in the display.

*** 5 9 #**

Dial

See section "Check and store received messages".

Retrieve messages - externally

To retrieve your messages from an external position:

Go "off hook"



Dial your company's telephone number



Dial the number to the mailbox system

During the procedure you will be asked for your extension number and your password.

Personal greeting

Depending on the type of diversion you want to activate, you can leave three different personal greetings to the caller. The diversion state can be on no reply, on busy or an activated individual diversion.

✖ 5 9 #

Dial



Press

During the procedure you will be asked for your extension number and your password.

2

Press to configure your personal greeting



Enter diversion code

Select an option below and follow the voice announcements.

<i>Type of diversion</i>	<i>Code</i>
Diversion greeting on busy	1
Diversion greeting on no reply	2
Individual diversion greeting	3

#

Press to store the recorded greeting

When you activate the diversion, the recorded greeting is played to the next caller.



Press to end

Note: *When you have activated a diversion with a personal greeting, callers will receive this greeting instead of your activated absence information.*

Abbreviated Numbers

By using abbreviated numbers, you can make calls simply by pressing a few keys. Frequently used external numbers are stored as "common abbreviated numbers" in the exchange.

Up to 10 "individual abbreviated numbers" (your personal most frequently used external numbers) can be stored and used on the keys "✳ ✳ 0" to "✳ ✳ 9".

Common abbreviated numbers

External numbers are stored centrally in your BusinessPhone system. Common abbreviated numbers can be dialed from every extension that has the authority to do so.



Dial the common abbreviated number

Please refer to your telephone directory.



Press to make the call

Individual abbreviated numbers

You can program and activate your most frequently used external numbers on the keys "× × 0" to "× × 9".

× ×

Press



Dial the abbreviated number

A number between 0 and 9.



Press to make the call

Program individual abbreviated number

How to program external numbers on the keys 0 to 9.

× 5 1 ×

Enter programming mode



Select an abbreviated number between 0 and 9 and press



Dial the number and press

The number can consist of up to 24 digits.

Cancel one specific individual abbreviated number

5 1 ×

Press



Enter an abbreviated number between 0 and 9 and press

Cancel all individual abbreviated numbers

5 1

Press

Confirmation tone.

Dial-by-name

You can call someone by pressing the first character(s) of a name and then scroll through the name list to search for the name and number.

Example:

Call "Kim" (ext. no. 123):

5 Press and hold until the display shows the first name beginning with K



Kate 432



Scroll up or down the name list until you find Kim

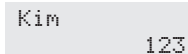

Kim 123



Confirm and Kim's number will be dialed

Note: You can press the "Cancel-key" instead of "YES" if you want to edit the number before dialling.

Group Facilities

When you are working together in a team the following group facilities can be very useful.

Group hunting

Your telephone can be included in one or several hunt groups. In a hunt group all members are represented with one common directory number. 16 hunt groups can be programmed, each containing 1 to 20 members. A member can be either an extension number, an operator console or a fictive number. Please ask your system administrator if you require this function.

Note: *The number of cordless extensions in a hunt group are limited to eight (including tandem configurations).*

Incoming calls to the hunt group are directed to free extensions in the group. The hunt order within the group can be changed to suit your needs. If no one answers this call before the programmed time, the call is forwarded to the programmed answering position (e.g. operator).

Note: *If all members in a hunt group are busy, the call-back or intrusion functions are not available, however the camp-on function can still be used.*

Log in

Before you can answer group hunting calls, you must log in.

To log in to one hunt group:

*** 2 8 ***



Dial

Dial the hunt group code

Please ask your system administrator for the configured number.

#

Press

To log in to all hunt groups:

*** 2 8 * * #**

Dial

Answer calls

Answer group hunting calls in the normal way.

Log out

To log out from one hunt group:

2 8 *



Dial

Dial the hunt group code

Please ask your system administrator for the configured number.

#

Press

Note: If you are logged in to more than one huntgroup and log out from one of them, the display will show the following text:

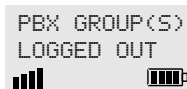

To log out from all hunt groups:

2 8 * *

Dial

Group call pick up

In a Pick up group, any member can answer any individual call to group members. You answer a call to the group by dialling a special answering number. Please ask your system administrator for the configured number.



Dial the group call pick up code

Common bell

The common bell facility allows all extensions of the system (operator included) to pick up the call from an extension that has been predefined as a common bell extension.



Dial the common bell pick up code

Please ask your system administrator for the common bell pick up code.

If two or more extensions simultaneously attempt to answer a call from the common bell extension, only the first extension will pick it up. The other extensions will receive the "number unobtainable" tone. This will also happen if you dial the common bell pick up code and there are no calls waiting at the common bell extension.

Other Useful Facilities

By using these facilities your productivity will be increased, e.g. you can set reminders for important meetings, place the costs for external calls on separate accounts and much more...

Reminder

The phone can be set to remind you at any time within the next 24 hours (multiple settings are allowed).

*** 3 2 ***

Dial

0000
0000
0000 #

Dial reminder time and press

(00-23) hour + (00-59) minute. When the time is reached your phone rings with recall signal.

***Note:** If you receive busy tone, your extension does not have the authority to set a reminder.*

Cancel reminder

3 2

Dial to cancel all settings

Automated attendant

The Automated Attendant facility sends voice instructions to external and internal callers, informing them of all possible options they can choose. Voice instructions lead the callers step by step to the desired destination.



Dial the Automated Attendant directory number

Please ask your system administrator for the Automated Attendant directory number.

Doorphone

The doorphone is used to monitor the admission to your company, i.e you can open the doorlock from your phone.

Answering doorphone calls



Press

You will be in speech connection with the calling party.

Opening of the doorlock

After you have answered the doorphone, you can open the door making an inquiry to the door-opener's directory number.



Press



Dial the door-opener's directory number

Please ask your system administrator for the number.

Account number

You can place costs for external calls on a selected account number (up to 15 digits).

✳ 9 ✳
 0000
 0000
 0000 #

Dial

Enter account number and press

Internal dial tone. Make the external call.

Direct Inward System Access (DISA)

If you are working externally and you have the need to make business calls, call your company and use the company PBX to make an external call to the desired party. You just pay the costs for the phone call to your company. The other costs will automatically be placed on your extension number or on a special project.

Note: To activate this function, you have to change the default password from "0000" to a personal one. Which code to use and how to change it, see section "Select password".

You can also divert calls from your office extension to your external position, see section "Call forwarding". During the procedure you will be prompted for your password. Use the quick reference card at the beginning of the guide to remember these specific numbers.

Go "off hook" and dial the public number of your company



followed by the DISA number

Ask the system administrator for the defined DISA number.

or

Use the external diversion function

Procedure, see section "Call forwarding".

Note: If you program a new diversion address, remember to reset it when you return to your office.

Tandem configuration

The tandem configuration is a unit, consisting of two telephones using the same directory number. One of the telephones is defined as the "Primary" and the other one as the "Secondary".

This function enhances the communication for users that, for example, have a wired phone on their desk (the "primary telephone") and need to be mobile within their company's building with their own portable (the "secondary telephone"). Basically the tandem configuration works as follows:

To activate the tandem configuration

*** 2 8 #**

Dial to log on the secondary telephone

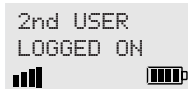

For incoming calls:

- Both telephones are treated as 1 single extension.

For outgoing calls:

- Both telephones are treated as 2 separate extensions.

To deactivate the tandem configuration

2 8

Dial to log off the secondary telephone

For incoming calls:

- The "secondary" telephone cannot be called and the "primary" telephone works as a normal "stand-alone" telephone.

For outgoing calls:

- Both telephones are treated as 2 separate extensions.

Transferring a call between members of a tandem unit



Press and dial own directory number

Go "on hook" to transfer the call

Networking

Networking is the connection of several premises within a company. The connection can be set up via leased lines, public lines, Local Area Network (LAN) or Wide Area Network (WAN). Ask your system administrator about details regarding networking.

IP calls

IP calls are internal calls sent via an internal data network (LAN or WAN) and the transfer of data and voice is made on the same line. If you are connected to an internal data network the IP connection is made automatically. To minimise the traffic on the network the speech quality is decreased.

If the speech quality is not acceptable you can disconnect the IP call and switch to a non-IP call (alternative network). The switch from the IP net to the non-IP net is made during the call, so the call does not have to be disconnected.

If you want to switch to a non-IP net during the call:



✳ 6 1 ✳

Press

Dial

During the procedure the other party is put on hold. When the procedure is ready you will receive a special ringing tone and the call is resumed in the non-IP net.

Note: A switch to a non-IP call can only be performed if the original call is an IP call, otherwise you will receive a blocking tone.

Security

You can block your extension in order to prevent unauthorized use of your telephone, e.g if your external calls are placed on a specific account number.

Block extension

*** 7 2 #**

Dial to block your extension

Verification tone.

Un-block extension

7 2 *

Dial



Dial your password

#

Press to re-open

Verification tone. Your extension is open for use.

Select password

You can use your four-digit password for blocking your phone from unauthorized use, or for making external calls from any blocked extension.

* 7 2

Dial to select a new password



Dial your present password

The default password is "0000".

*

Press



Dial your new password

#

Press

Verification tone.

Bypass blocked extension

In order to make a call, you can temporarily bypass a blocked extension.

Bypass own extension

✳ 7 2 ✳



Dial

Dial your password

#

Press

Dial tone. You can make one call from your extension.

Bypass another extension

This makes it possible to make a call on another, blocked extension, by using your password.

✳ 7 2 ✳



Dial

Dial your password

✳

Press



Dial your extension number

#

Press

Dial tone. You can make one call from the blocked extension.

Least Cost Routing

Least Cost Routing (LCR) automatically selects the cheapest way to establish the connection to the desired external number. Please ask your system administrator if this function is installed in your system. If the extension has been configured to use LCR, each external call will be analysed and the cheapest way will be selected.

Use least cost routing

0 0000
0000
0000

Dial the digit(s) for external call access and the external number

The usual way of making an outgoing external call.

Calling least cost routing

If LCR has been installed in your system, but your extension is not configured to use it automatically, you also have the opportunity to get the cheapest connection by dialling the LCR code before you dial an external number.

○ ○ ○ ○

Dial the LCR code

Please ask your system administrator for the LCR code.

0 0000
0000
0000

Dial the digit(s) for external call access and the external number

Phone Book

Your portable is equipped with a personal phone book where you can make up to 100 entries (names and numbers).

Notes:

- *It is not possible to download a pre-programmed phone book to the DT288.*
 - *Phone book numbers have a maximum of 24 digits.*
 - *Phone book names have a maximum of 12 characters.*
 - *An indication that the phone book is full, means that you have to delete an entry before you can add a new one.*
-

Use the phone book

Access the names and numbers of the phone book.



Access PhoneBook



Use the arrow keys to select the required option

Make a call via the phone book

When you have accessed the phone book:



Access Find&Call



Press the key which has the first letter of the name you are looking for

How to write text, see section "Write text".



Press to confirm

The first name beginning with that letter is displayed.



Scroll up or down until you find the name and press

The number is dialed.

Note: How to make calls via the who called- and last dialled lists, see sections "Incoming calls" and "Outgoing calls".

Add a name or a number to the phone book

When you have accessed the phone book:



Access Store



Access AddNew

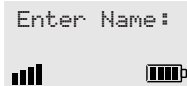

Enter a name and press

How to write text, see section "Write text".



Enter the telephone number and press

The name and number are stored in the phone book.

Change a name or a number in the phone book

When you have accessed the phone book:

Note: If you only want to change a name or a number press "YES" instead of "NO" to proceed, otherwise all changes will be cancelled.



Access Find&Edit



Access Edit



Enter the first letter of the name and press



Scroll up or down until you find the name



Press once to change a name

Note: Press "YES" twice to change a number.



Correct the name or number



Press to confirm

Note: Only press "YES" once if you have changed a number.

Delete a name or a number from the phone book

When you have accessed the phone book:



Access Find&Edit



Access Delete



Enter the first letter of the name and press



Scroll up or down until you find the name



Press to delete the name and number

Delete all names and numbers



Access DeleteAll

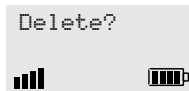

Press to delete all names and numbers

Note: When `Delete?` is selected the entire phone book is deleted and cannot be restored.

Add a last dialled number to the phone book

When you have accessed the phone book:

Note: You can only add names or numbers if they are available for redial.



Access Store



Access AddLastDial

The list of last dialled numbers is displayed.



Scroll up or down until you find the number to add



Select the number and press

You can edit the displayed number.

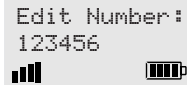

Press



Enter a name and press

The name and number are stored in the phone book.

Add a who called number to the phone book

When you have accessed the phone book:

Note: You can only add names or numbers if they are available for returning a call.



Access Store



Access AddWhoCall

The list of who called numbers is displayed.



Scroll up or down until you find the number to add



Select the number and press

You can edit the displayed number.



Press



Enter a name and press

The name and number are stored in the phone book.

Write text

The characters that you can enter, are written above each key. Use the keypad to write text. Below is explained how to write text when you add a new name in the phone book menu.



Access Store

The portable changes to text entry mode automatically.



Example:

5

Press a digit

1 time result J
2 times result K
3 times result L
4 times result 5



Press to confirm your edit and exit the menu

Control keys

While entering a name or a number you can use the following keys for control and navigation:



Press to move left



Press to move right



Press to switch between upper and lower case

Note: Pressed for more than one second will add a dial tone pause.

1

Press to enter a space



Press to correct a wrong entry

Special characters

See the table below how to find a special character.

Number of keypresses

Key	1	2	3	4	5	6	7	8	9	10	11	12	13
1		-	?	!	,	.	:	"	'	()	1	
2	A	B	C	Å	Ä	Æ	À	Á	Â	Ã	Ç	2	Γ
3	D	E	F	È	É	Ê	Ë	3	Δ	Φ			
4	G	H	I	Ì	Í	Î	Ï	4					
5	J	K	L	5	Λ								
6	M	N	O	Ñ	Ö	Ø	Ò	Ó	Ô	Õ	Œ	6	
7	P	Q	R	S	ß	7	Π	Σ					
8	T	U	V	Ü	Ù	Ú	Û	8					
9	W	X	Y	Z	ÿ	9							
0	0	+	&	@	/	\$	%	£	Θ	Ξ	Ψ	Ω	
#	#	*											

Note: Depending on the selected menu language, other characters might be available, which means that the character order differ from the table above.

Example special characters:

8 To enter Ü press 8 (four times)

1 time	result	T
2 times	result	U
3 times	result	V
4 times	result	Ü



Press to confirm your edit and exit the menu

Adjustments

This section describes how to set and adjust a personal volume and how to revert all DT288 settings to default.

Volume control

Use the volume keys to adjust the volume in the earpiece. The volume keys have an auto repeat function. See section "Description" for the location of volume controls. To turn the microphone, ringer and warning sound on or off during a call, see section "During calls".

Earpiece volume

When you are making a call, the volume keys affect the earpiece volume. This is useful when e.g. you enter a machinery or a computer room. The earpiece volume can also be adjusted in idle state (on hook). The earpiece volume can be set to 10 different levels.



Press to adjust the earpiece volume during a call

Ringer volume

There are 7 ringer levels. At the lowest level, the ringer is shut off.



Access Handset



Access Alerts

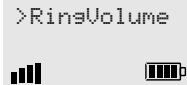

Press

A volume level bar is displayed.



Use the arrow keys to set the suitable level



Press to confirm

Turn off ringer permanently

You can also turn the ringer off permanently.

When the phone is on hook:



Press

The ringer off icon is displayed.



Press and hold to turn the ringer on again

The ringer off icon disappears.

Reset the DT288 settings

You can simultaneously reset (clear) the last dialled numbers, the who called numbers and the last call information.

Note: *The phone book, the PIN code, the subscriptions and the total calls information are not reset.*



Access Handset



Access MasterReset



Enter PIN code and press (if required)

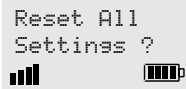

Press to confirm

All DT288 settings revert to default.

Glossary

Abbreviated Number Dialling

Initiating a call to a pre-programmed number by dialling a code or pressing a key.

Short numbers can be:

1. *Common, which means that all extensions can use them.*

2. *Individual, which means that they are programmed and used by each extension separately (10 numbers).*

See section "Abbreviated numbers".

Account Number

To place costs for external calls on a selected account number (up to 15 digits).

See section "Other useful facilities".

Automated attendant

A facility which sends voice instructions to internal and external callers, providing all options which can be chosen. Voice instructions lead the caller to the desired destination.

See section "Other useful facilities".

Call-back

An indication to a busy extension, to inform the person that you want to speak to him/her.

See sections "Internal messages" and "Outgoing calls".

Camp on

To place (queue) a call to a busy extension.

See section "Outgoing calls".

Dial-by-name

Initiation of a call by operating a single key. Internal numbers (or common abbreviated numbers) can be stored on each extension. See section "Abbreviated numbers".

Directory number

Numbers with 1-8 digits which are assigned to extensions or external lines or as common abbreviated numbers.

Direct Inward System Access (DISA)

If you are working externally, the DISA function enables you to make external calls (long distance) via the company PBX. You only pay for the call to your company. See section "Other useful facilities".

Diversion

Incoming calls to an extension are diverted to another directory number (extension, common abbreviated number or the operator).

There are three possibilities:

1. *Direct, which means that all calls to an extension are forwarded directly.*

2. *On no reply, which means that a call is forwarded if it is not answered within a certain time.*

3. *On busy, which means that a call is forwarded if the extension is busy.*

See section "Call forwarding".

Diversion Bypass

This is useful for letting urgent calls through to an extension where diversion is active.

See section "Call forwarding".

Extension

All telephones connected to the PBX have a unique internal number (up to 8 digits). If your telephone is equipped with a display, you can see your number.

Information

Internal callers are informed about absence and time of return. External callers are diverted to the operator, where the same information is available. Information can be of two kinds:

1. *Pre-programmed text information.*
2. *Voice information.*

Intrusion

To intrude on an ongoing call when a requested extension is busy. See section "Outgoing calls".

IP call

Internal call sent via an internal data network (LAN or WAN).

ISDN

Integrated Services Digital Network. Provides your system with supplementary services from the public net.

Least cost routing

A function that automatically selects the cheapest way to connect your external call (not necessarily the shortest distance). See section "Least cost routing".

Mailbox

The mailbox system controls the messages that are left for or sent by you when you are absent. See section "Mailbox system".

Message

A message can be sent to any extension. This is useful when you receive the busy tone or get no answer. There are two kinds of message:

1. *"Call me" message.*
2. *Voice message.*

See section "Internal messages".

Mute microphone

To switch the microphone temporarily off. See section "During calls".

Password

A four-digit code needed to e.g. block your extension and retrieve messages from the mailbox system. You can set your own password. See section "Security".

PBX

Private Branch Exchange. Your telephone switching system (e.g. BusinessPhone 250).

Pre-defined text

Pre-programmed absent information. See section "Information".

Third party

A third connection (person), which can be included in an ongoing two person conversation. The connection can be internal or external. See section "During calls".

Tie line

An external line from the private network.

Transfer

During an internal or external ongoing call you can make an inquiry and then transfer the call to another party (internal or external). See section "During calls" and "Useful hints".

Trunk line

A trunk line is the same as an external line. Can be either digital or analog.

Installation

This chapter describes the battery (how to connect and charge) and how to connect the clip to the back of your portable.

Connecting the battery

Your portable is supplied with a high capacity nickel metal hydride (NiMH) battery.

Notes:

- An alarm sounds when there is less than 15 minutes calling time left in the battery.
- Because the status of a newly received battery is uncertain, always charge it to ensure that you have sufficient talk and standby time.

Attach the battery to the portable as shown in the figure below

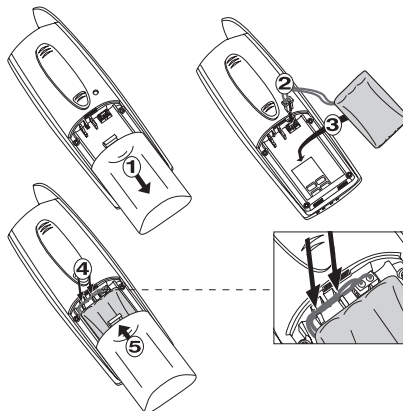

Battery performance

The table below indicates the performance:

	<i>Talk time (hours)</i>	<i>Standby time (hours)</i>	<i>Charge time (minutes)</i>
High capacity battery:	15	100	180

Connecting the clip

Connect/disconnect the clip to the back of the portable as shown in the figures below

Clip connection

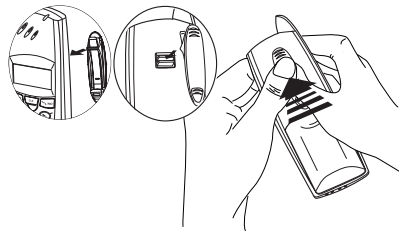

Clip disconnection

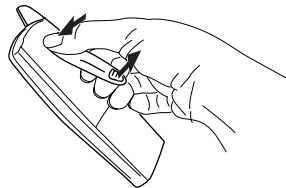

Note: Do not put your fingers on the display when you press. You can remove the clip, but do not do this too often, because this may wear out the fastening.

Connecting the charger

Connect the adapter to the charger and connect it to the mains outlet as shown in the figure below

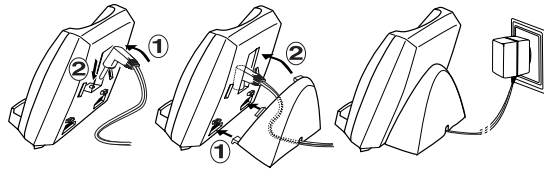

Charging the battery

When the battery requires charging, you will hear a warning sound and the display will indicate it. Regarding charge time, see section "Battery performance".

Connect the portable to the charger as shown in the figure below

The charging process will start automatically, indicated by a fast flashing battery icon and a green light on the charger. When charging is complete, the icon stops flashing and the green light is turned off.

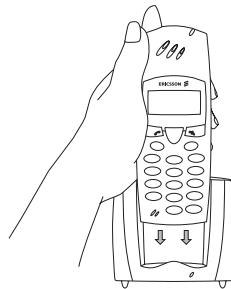

Notes:

- Do not connect the portable to charger without a battery.
- If the battery is completely flat it can take a few minutes before the green light on the charger is lit.
- If the standby time for your DT288 becomes too low, you should replace the battery.
- Only use the charger that is delivered with your portable to charge the battery.

Troubleshooting

This section contains information on how to solve common operational problems. Go through the following steps if you encounter any problems. If this does not solve the problem, contact your system administrator. If others have similar problems, there may be a system error.

Fault check list

Fault	Probable cause	Action or comment
No display	Battery low or portable defect	Charge battery
Display shows Connect battery	Battery not properly fit or defect	Check battery or contact system administrator
No ringing	Ringer off icon on or portable defect	Off icon on= Adjust volume
Signal strength icon off	Out of coverage area, system or portable defect	Enter coverage area or contact system administrator
Battery icon flashes slowly	Battery low	Charge battery
Call icon on for 2 seconds	Portable defect	Contact system administrator

Fault	Probable cause	Action or comment
Battery icon on	Charging complete, charger still connected	Disconnect the charger
Phone Book Empty	No names or numbers stored in the phone book	Add names or numbers
Phone Book Full	Phone book full, you cannot add names or numbers	Delete a name or number
Subscr. List Full	Already eight subscriptions	Delete a subscription
Subscription Failed	Entered AC number does not match network AC or network cannot add another subscription	Try to subscribe again
Enter XXX (where XXX=IPEI, PIN or AC)	IPEI code, PIN code or AC number missing	Enter required IPEI, PIN or AC
No Access	Network in range, but no access rights	Select another network or resubscribe
No Network	Cannot connect to selected network or out of range	Select another network, subscribe, get back within range or contact system administrator
PIN Blocked Unblock?	Phone blocked, wrong PIN code entered three times	See section "Important/ IPEI code"

Contact your system administrator if one of these error messages is displayed:

System List Error
Buzzer Data Error
User Data Error
User Phone Book Error
Error :xx (where xx=any number)

Useful Hints

Connections between external lines

With your BusinessPhone PBX, you can establish an external call diversion or a conference with more than one external party or transfer an external call to another external destination (e.g. a mobile phone). These features are very useful for everyday business life.

Note: *When these features are used, your BusinessPhone will occupy at least two external lines.*

However, there may be disadvantages in connecting to several external lines. We would therefore like to draw your attention to the following:

- **Please do not transfer external calls to an external mailbox, to information systems or to external parties before they have answered**
- **Try to avoid diverting calls to third parties before they have answered**
- **If you are connected to two external lines, cancel one call by pressing "R" and "1"**

If the external parties are not persons (mailbox, automated information or attendant systems, etc.), connections on external lines can last a long time, which can be costly. Moreover, such calls may occupy two of your system's external lines. You can restrict connections between the external lines by re-programming your system.

Please ask your system administrator or contact our service center for more information.

Index

- Abbreviated numbers 39
 - Common 39
 - Individual 40
- Account number 47
- Adjustments 62
- Answer calls 15
- Automated attendant 46
- Automatic call-back 18
- Battery 67
- Block extension 50
- Busy extension 19
- Bypass blocked extension 52
- Bypass call forwarding 29
- Call forwarding 24
 - Bypass 29
 - Fixed diversion 25
 - Follow me 28
 - Individual 26
- Call me-message 33
- Camp-on 19
- Charging 69
- Check and store received messages 34
- Common abbreviated numbers 39
- Common bell 44
- Conference 21
- Coverage area 6
- Description 10
- Dial mode 22
- Dial-by-name 41
- Dictaphone function 35
- Direct Inward System Access (DISA) 47

- Display info 11
- Diversion on busy 24
- Diversion on no reply 24
- Doorlock 46
- Doorphone 46
- During calls 20
 - Conference 21
 - Dial mode 22
 - Inquiry 20
 - Mute 23
 - Transfer 20
- Enter information 30
- Erase information 32
- External calls 17
- External diversion 27
- Fault check list 70
- Fixed diversion 25
- Follow me 28
- Glossary 65
- Group call pick up 44
- Group facilities 42
 - Common bell 44
 - Hunt group 42
 - Pick up group 44
- Group hunting 42
- Guidelines 9
- Important 6
- Incoming calls 15
- Individual abbreviated numbers 40
- Individual diversion 26
- Individual mailbox system 36

- Information 30
 - Code 31
 - Completing info 31
 - Enter 30
 - Erase 32
 - Save 32
 - Text 31
 - Voice 32
- Inquiry 20
- Installation 67
 - Battery 67
 - Battery performance 68
 - Charger 69
 - Charging 69
 - Clip 68
- Internal calls 17
- Internal diversion 26
- Internal messages 33
- Intrusion 19
- IP calls 49
- IPEI code 8
- Last external number redial 18
- Least cost routing 53
- Mailbox system 36
 - Individual 36
 - Personal greeting 38
- Make calls 17
- Menu structure 13
- Messages 33
 - Call-back 33
 - Check and store 34
 - Dictaphone 35
 - Record 35
 - Send 33
 - Voice 33
- Mute microphone 23
- Mute ringer or warning 23
- Network (menu option) 9
- Networking 49
- Other useful facilities 45
- Outgoing calls 17
 - Busy extension 19
 - Call-back 18
 - Camp on 19
 - Intrusion 19
 - Make 17
 - Off hook 17
 - Redial 18
- Password 51
- Personal greeting 38
- Phone book 54
 - Add a last dialled number 58
 - Add a name or a number 55
 - Add a who called number 59
 - Change a name or a number 56
 - Delete a name or a number 57
 - Make a call 55
 - Special characters 61
 - Use 54
 - Write text 60
- PIN code 7
- Pre-defined texts 31
- Preparing for use 6
- Record message 35
- Redial number from Last Dialed list 18
- Reminder 45
- Reset the DT288 settings 64
- Save information 32
- Second telephone 48
- Security 50
- Select password 51
- Send message 33
- Short numbers 39
- Switching on/off the portable 14
- Tandem configuration 48
- Transfer 20
- Troubleshooting 70
- Two telephones 48
- Un-block extension 50
- Un-block the DT288 8
- Useful hints 73
- Voice information 32
- Voice message 33
- Volume 62
- Who called list 16
- Write text 60

Voice guide for the integrated mailbox system

A pocket-size voice guide, that will help you with the integrated mailbox system, for example useful when you are on the move.

Answer calls

Answer: 

Suppress ringing: 

Make calls

Internal calls: *Extension No.* **or**
External No. 

Common abbreviated number: *Abbreviated No.* 

Individual abbreviated number: *** * *** *Abbreviated no. 0-9*

Last external number redial: *** * *** 

You get busy tone or no answer

Automatic call-back: **5** 
Go "off hook" when called back



Camp on: **4** *Stay off hook*

Intrusion: **8**



Inquiry

Ongoing conversation:  Call 3rd party

Conference

Ongoing conversation:  Call 3rd party
 **3** (To establish)
 (To leave)

Transfer

Transfer a call:  Call 3rd party

(Before or after answer)

Tandem configuration

Activate: *** 2 8 #**

Deactivate: **# 2 8 #**

Transfer a call between members:  *Own directory No.*
Go "on hook" to transfer the call

Messages

"Call me": **9 #**

Voice: **9 9** *Speak*

Play-back: *****

Re-record: **9** *Speak*

Send: **#**

Receive messages: *** 5 9 #**

Call forwarding

Fixed diversion: *** 2 1 #**

Internal diversion: *** 2 1 *** *New No. #*

Cancel internal diversion: **# 2 1 #**

Follow me, re-direct from answering extension: *** 2 1 *** *Own No. **
New No. #

Cancel from answering extension: **# 2 1 *** *Own No. #*

Bypass call forwarding: *** 6 0 *** *Ext. No. #*

External diversion: *Program:* *** 2 2 ***
Line access code
External No. #

Cancel: **# 2 2 #**

Re-activate: *** 2 2 * #**

Ericsson communications solutions for enterprise networks combine and improve advanced ways of exchanging information via voice, data, video and evolving future media.

This requires a true understanding of how businesses and professionals interact – an understanding that goes far beyond meeting just the technological requirements.

Our customers include owners of small to large enterprise networks, local as well as multinational. We also offer solutions for Internet service providers.

We deliver quality of service over converged networks. We provide staff with full onsite and offsite mobility.

We integrate computer and telephony applications on the desktop. We enable coordination of all business interactions over the media of choice. In essence, we help businesses forge enduring relationships with customers.

Ericsson is the leading provider in the new telecoms world, with communications solutions that combine telecom and datacom technologies with the freedom of mobility for the user. With more than 100,000 employees in 140 countries, Ericsson simplifies communications for its customers - network operators, service providers, enterprises and consumers - the world over.

