

Intelligent Hybrid System



**Multiline Telephone
Quick Reference Guide**

Before using Your Telephone...

Thank you for purchasing the NEC "Xen Topaz" system.

Due to the flexibility built into the system, your **Dialling Codes and Feature Capacities** may differ from those in this guide. Check with your Supplier / System Administrator and make a note of any differences.

Using Your Telephone < Multiline Telephone >

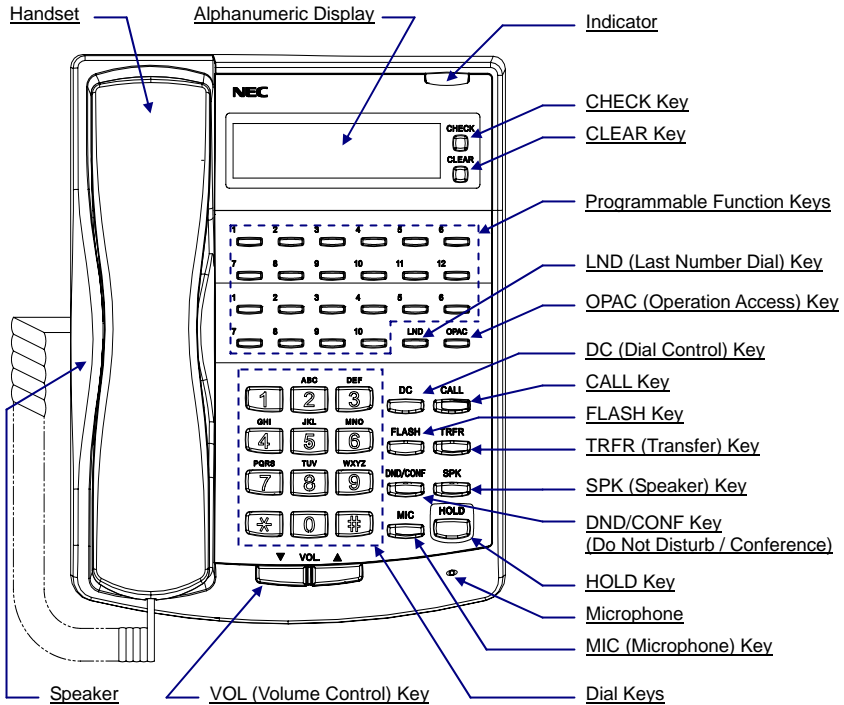

Functions	12TXD	12TD	6TXD	6TD
Programmable Keys	12	12	6	6
Additional Prg. Keys	10	10	10	10
Display	Yes	No	Yes	No
CHECK/CLEAR Keys	Yes	No	Yes	No
Handsfree	Yes	No (Talkback)	Yes	No (Talkback)
Accept DLS Console	Yes	No	Yes	No
Wall Mount Kit	Yes (Built-in)	Yes (Built-in)	Yes (Built-in)	Yes (Built-in)

Handsfree Options

- Handsfree lets you place and answer calls by pressing "SPK" instead of using the handset.
- With Automatic Handsfree, you can press a CALL Key without lifting the handset. Normally, you have Automatic Handsfree.
- Use Handsfree Answerback to answer a voice-announced Intercom call by speaking toward your phone without lifting the handset.

For Your Convenience

Program Function Keys

Programmable Function Keys can be assigned as "Trunk" Key and/or other Function Keys. You can just press the function key to activate the assigned function without dialling the Service Code.

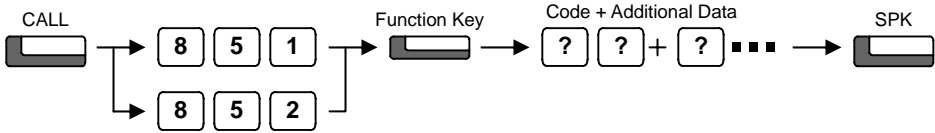

- ◆ There are 2 levels of Function Keys. (General Keys : assigned by 851, Appearance Keys : assigned by 852)
- ◆ Appearance Keys have priority. You can overwrite the Appearance Key at the General Key.
- ◆ If you want to overwrite the General Key at the Appearance Key, you have to erase the Appearance Key by dialling "852 + 000" before General Key assignment.
- ◆ In the default setting, Programmable Function Key No. 1 to 12 is assigned as "Trunk" Key. If you want to assign Function Keys (General) at the unused Trunk Keys, these unused keys should be erased by "852 + 000" operation.
- ◆ Programmable Function Keys can be erased by dialling "852 + 000" or "851 + 00".

Program DSS/One-Touch Keys

Programmable Function Keys can be assigned as DSS (Direct Station Selection) or One-Touch Keys. You can place an Outside / Intercom Call just pressing this key without dialling the number.

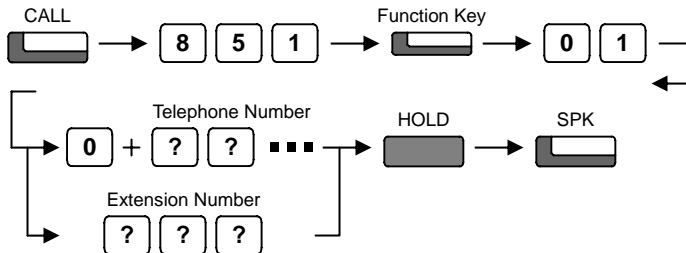

- ◆ In the default setting, Programmable Function Key No. 1 to 12 is assigned as "Trunk" Key. If you want to assign DSS Keys at the unused Trunk Keys, these unused keys should be erased by "852 + 000" operation before the above operation.
- ◆ In case of DSS Key, the extension status can be indicated on the BLF. (idle : extinguished, Busy : lit)
- ◆ When you register a telephone number, "9" (Trunk Access Code) should be added on top of number.
- ◆ Up to 24 digits dialling can be registered, but the name can not be registered.
- ◆ If you want to continue the operation, press Programmable Function Key instead of SPK to finish.

For Your Convenience

Register Abbreviated Dialling <Display Key Telephone>

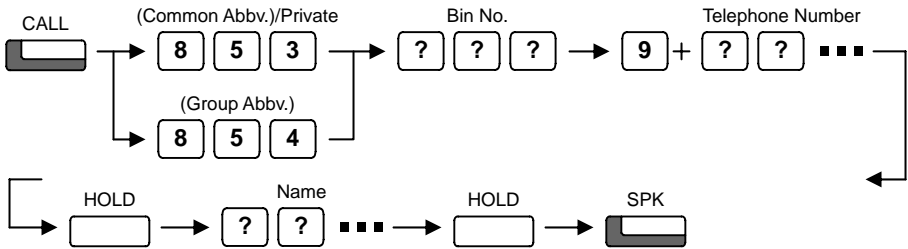

- ◆ The digit of Bin No. depends on the system setting. (0-9 / 00-99 / 000-999)
- ◆ System setting is necessary for Group Abbv. function. Ask your Supplier for more details.
- ◆ Name can be entered by Dial Pad Keys. (See below)
- ◆ Up to 24 digits dialling can be registered, and up to 12 characters can be registered as name.
- ◆ If you want to continue the operation, dial Bin No. instead of SPK Key to finish.
- ◆ You can skip to enter the name. (No enter any character, then press "HOLD" Key).
- ◆ You can erase the registered number & name by pressing "CLEAR" Key after dialling Bin No..

Entering Alphanumeric Characters

When you enter a name, use Dial Pad Keys to enter letters as below. For example, press "2" key once for "A", twice for "B", etc...

	Number of Key Presses												
	1	2	3	4	5	6	7	8	9	10	11	12	13
1	1	@	[¥]	^	_	'	{	}	→	←	
2	A	B	C	a	b	c	2						
3	D	E	F	d	e	f	3						
4	G	H	I	g	h	i	4						
5	J	K	L	j	k	l	5						
6	M	N	O	m	n	o	6						
7	P	Q	R	S	p	q	r	s	7				
8	T	U	V	t	u	v	8						
9	W	X	Y	Z	w	x	y	z	9				
0	0	!	"	#	\$	%	&	'	()			
*	*	+	,	-	.	/	:	;	<	=	>	?	

Accepts a character and moves the cursor one place to the right. Press twice to insert a "space".

DND/CONF Clear the character entry to the left, one character at a time. (Backspace Key)

Placing Calls

Place an Outside Call <Quick Access>

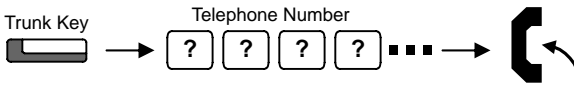

- ◆ Listen for Dial Tone before dialling a Telephone Number.
- ◆ You can have function keys for Trunks or Trunk Groups. Ask your Supplier.

Place an Outside Call <Access by Code>

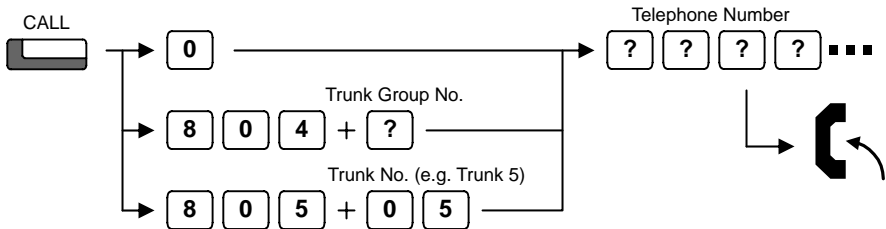

- ◆ Listen for Dial Tone before dialling a Telephone Number.
- ◆ In case the number of Trunk Group is more than 10, you should enter 3 digits (e.g. 011 : Group 11) after dialling "804". Ask your Supplier more details.

Place an Intercom Call <Dial Access>

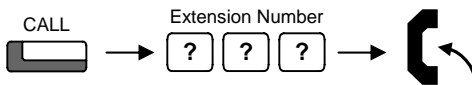

- ◆ Pressing CALL key after dialling an extension number is also possible.
- ◆ Your call will ring or voice-announce. If you hear ringing, wait for an answer. If you hear a beep, begin speaking. Dialling "1" changes voice/ring mode. (in case the destination is Key Telephone)

Placing Calls Quickly

Abbreviated Dialling <for Outside>

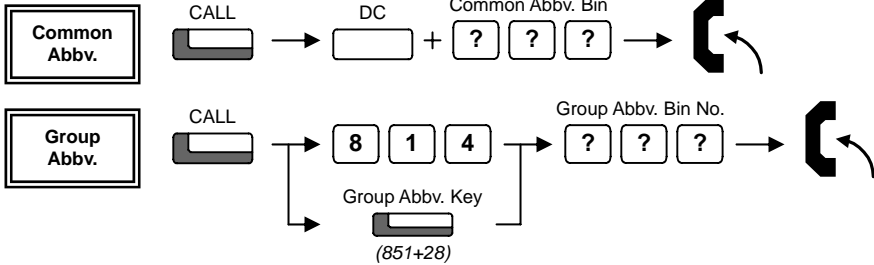

- ◆ The digit of Bin No. depends on the system setting. (0-9 / 00-99 / 000-999)
- ◆ Telephone Numbers shall be pre-registered to the system.
- ◆ System setting is necessary for Group Abbv. function. Ask your Supplier for more details.

One-Touch Call <for Outside / Intercom>

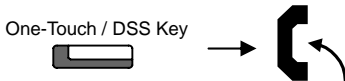

- ◆ The Telephone / Extension Number shall be pre-registered to a One-Touch / DSS Key. (Refer to P.2)
- ◆ Trunk Access Code (Dial "0") should be added on top of Telephone Number.

Last Number Dialling <for Outside / Intercom>

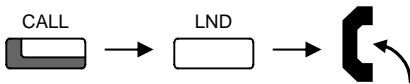

Redial List

The system retains the last 10 numbers dialled which can be viewed and dialled.
(For Display Key Telephone)

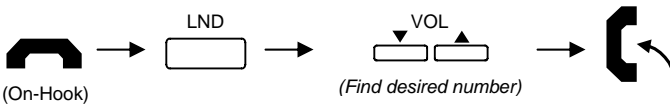

- ◆ Intercom Number can also be stored to LND. (System setting is necessary. Ask your Supplier.)

If your call doesn't go through...

Set Camp On / Callback

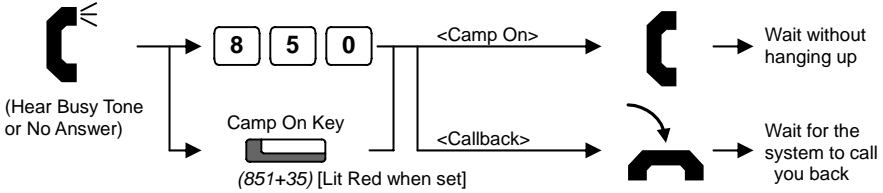

- ◆ <Camp On> In case of Intercom Call, when you hear ringing, wait for the called party to answer.
In case of Outside Call, when you hear Dial Tone, begin telephone number dialling.
- ◆ <Callback> In case of Intercom Call, when your phone starts the ringing, lift handset and wait for the called party to answer.
In case of Outside Call, when your phone starts the ringing, lift handset, hear Dial Tone, and begin telephone number dialling.
- ◆ This function is applicable in case all trunks are busy condition. (not applicable for dialled outside party busy)

Cancel Camp On / Callback

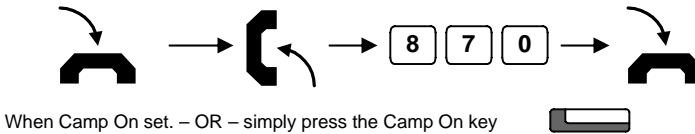

Set / Answer a Message Waiting

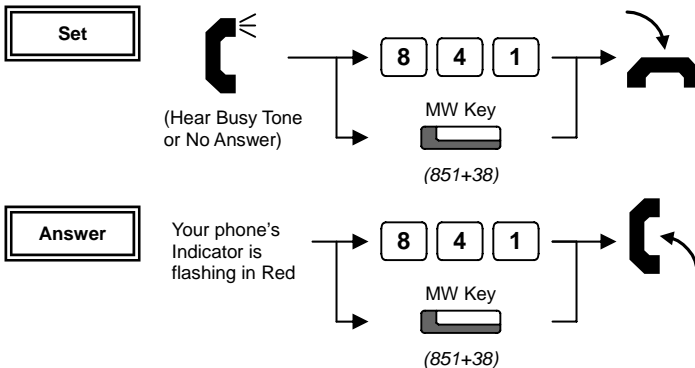

- ◆ When you set a MW, the called party's Indicator starts to flash, and your Indicator is lit in Red.
- ◆ When you answer a MW, the Indicator shall automatically be off when the called party answers.

If your call doesn't go through...

Check & Answer a Message Waiting <Display Key Telephone>

You can check who left a message to you, and then answer.

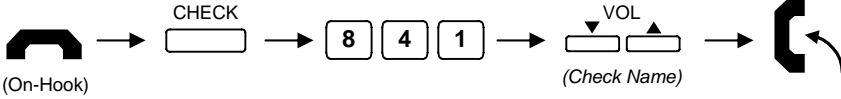

Cancel Message Waiting (Cancel Individually - at originated extension)

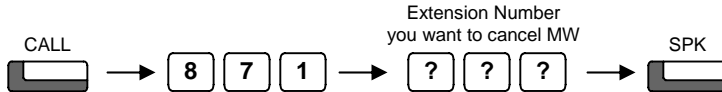

Clear all Message Waiting (at any extension)



◆ Clear all messages (you have left for other extensions and messages other extension have left for you).

Repeat Dialling <Outside Call>

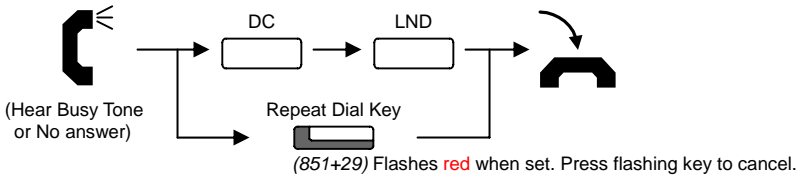

- ◆ The system periodically redials the call. Repeat duration is programmable. Ask your Supplier.
- ◆ You should lift the handset when the called party answered.
- ◆ You can cancel this function by pressing "DC" and "LND" during idle condition.
- ◆ Does not reserve line. Will select other available line when original line is in use.

Answering Calls

Answering an Outside Call

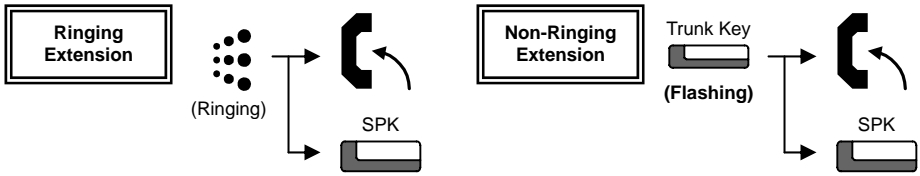

- ◆ Confirm the status of MIC Key if you want to answer by Handsfree. (MIC On : Light off, MIC Off : Light On)

Answering an Intercom Call

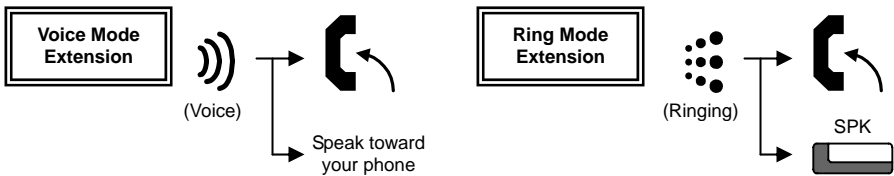

- ◆ Intercom Call Mode can be set at your phone by : "Ring" : CALL + 823 "Voice" : CALL + 821
- ◆ Confirm the status of MIC Key if you want to answer by Handsfree. (MIC On : Light off, MIC Off : Light On)

Picking up a call for other Extensions

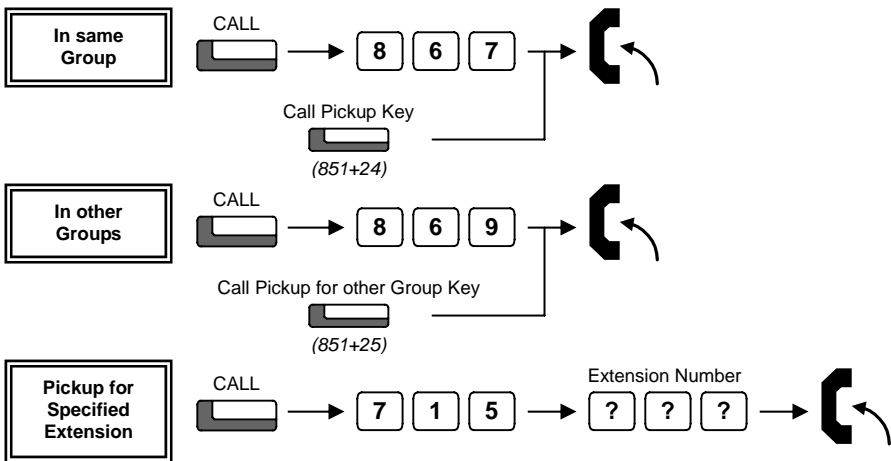

- ◆ System setting is necessary to make Call Pickup Group. Ask your Supplier.

Hold / Transferring Calls

Holding a Call / Retrieving a Held Call

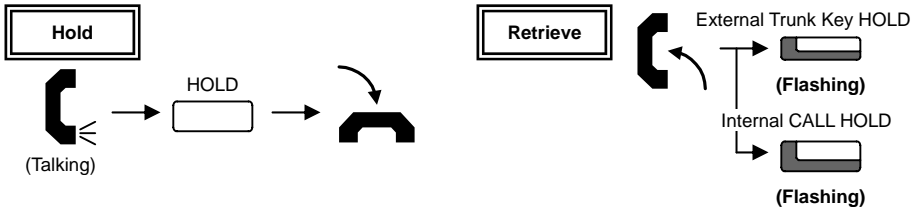

- ◆ In case of Intercom, the call shall be held as "Exclusive Hold" on your phone.
- ◆ This operation puts your outside call on System Hold. Other extension user can take the call off Hold.

Holding a Call Exclusively

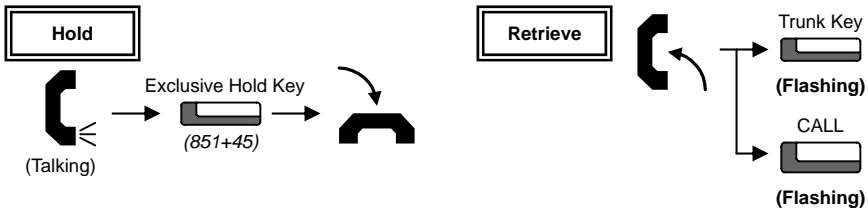

- ◆ System setting is necessary to use Exclusive Hold. Ask your Supplier.
- ◆ This operation puts your outside call on Exclusive Hold. Other extension user can not take the call off Hold.

Retrieve a held outside call (if your extension doesn't have Trunk Keys)

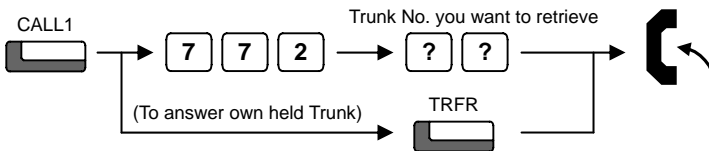

Transferring a Call to another Extension

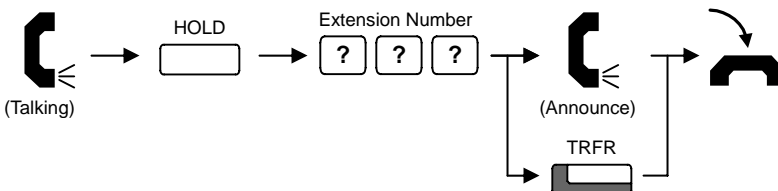

- ◆ If your phone has DSS or One-Touch key, just press it instead of "HOLD and Extension Number" operation.

For more convenient use...

Do Not Disturb (DND)

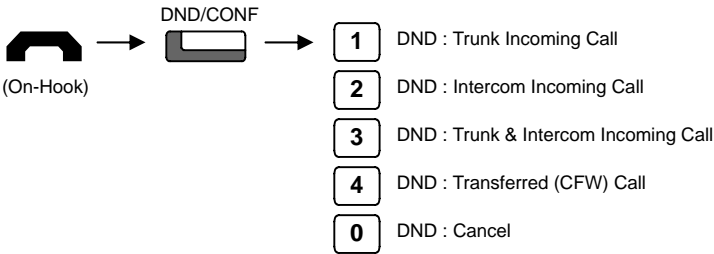

◆ When you set DND function, DND/CONF Key's lamp is lit and the Internal Dial Tone pattern is changed.

Call Forwarding / Follow Me

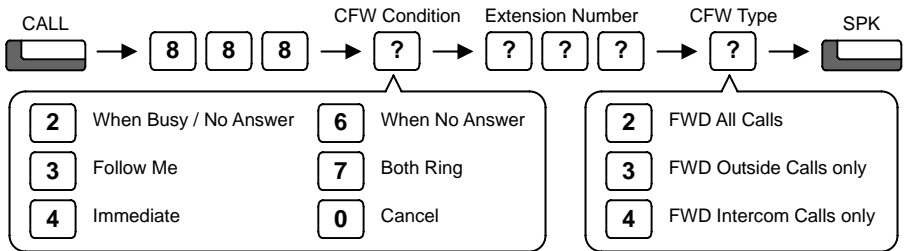

◆ When you set Call Forwarding function, DND/CONF Key's lamp flashes and Internal Dial Tone pattern is changed.

Conference

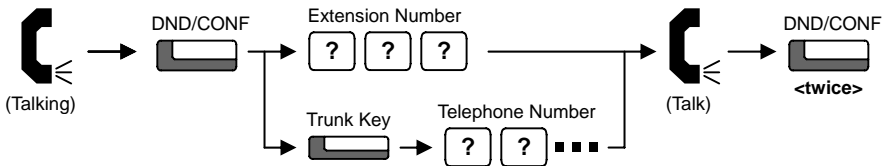

◆ You can repeat this operation to add more parties.
 ◆ You may be able to have up to 8 parties. (include your extension)

Nothing contained in this manual shall be deemed to be, and this manual does not constitute, a warranty of, or representation with respect to, any of the equipment covered. This manual is subject to change without notice and NEC Business Solutions Ltd has no obligation to provide any updates or corrections to this manual. Further, NEC Business Solutions Ltd also reserves the right, without prior notice, to make changes in equipment design or components as it deems appropriate. No representation is made that this manual is complete or accurate in all respects and NEC Business Solutions Ltd shall not be liable for any errors or omissions. In no event shall NEC Business Solutions Ltd be liable for any incidental or consequential damages in connection with the use of this manual. This document contains proprietary information that is protected by copyright. All rights are reserved. No part of this document may be photocopied or reproduced without prior written consent of NEC Business Solutions Ltd.

Copyright © 2004 by NEC Business Solutions Ltd
All Rights Reserved.