Litecraft[®]

ColorLED 12FC Zoom

ILED-CM-200Z



USER GUIDE

PLEASE READ THESE INSTRUCTIONS CAREFULLY BEFORE USE

CONTENTS

1. Safety Instructions	2
2. Technical Specifications	4
3. How To Set The Unit	4
3.1 Control panel.....	4
3.2 Main Function.....	6
4. Control By Universal DMX Controller	11
4.1 DMX 512 Connection	11
4.2 Address Setting.....	12
4.3 DMX 512 Configuration.....	13
5. Troubleshooting.....	15
6. Fixture Cleaning.....	16

1. Safety Instructions



WARNING

Please read carefully the instruction, which includes important information about the installation, usage and maintenance.



DANGER!
Safety hazard.
Risk of severe injury or death.



DANGER!
Hazardous voltage. Risk of lethal or severe electric shock.



WARNING!
Fire hazard.



WARNING!
LED light emission. Risk of eye injury.



WARNING!
Burn hazard. Hot surface. Do not touch.



WARNING! Refer to user manual.

- Please keep this User Guide for future consultation. If you sell the unit to another user, be sure that they also receive this instruction booklet.
- Please unpack and check carefully there is no transportation damage before using the unit.
- Before operating, ensure that the voltage and frequency of power supply match the power requirements of the unit.
- It's important to ground the yellow/green conductor to earth in order to avoid electric shock.
- The unit is for indoor use only. Use only in a dry location.
- The unit must be installed in a location with adequate ventilation, at least 50cm from adjacent surfaces. Be sure that no ventilation slots are blocked.
- Please disconnect main power before replacement or servicing.
- Please make sure there are no flammable materials close to the unit while operating as it is fire hazard.
- Please use safety cable when fixes this unit. DO NOT handle the unit by taking its head only, but always by taking its base.
- Maximum ambient temperature is T_a : 40°C. DO NOT operate it where the temperature is higher than this.
- Unit surface temperature may reach up to 85°C. DO NOT touch the housing bare-hand during its operation. Turn off the power and allow about 15 minutes for the unit to cool down before replacing or serving.
- In the event of serious operating problem, stop using the unit immediately. Never try to

repair the unit by yourself. Repairs carried out by unskilled people can lead to damage or malfunction. Please contact the nearest authorized technical assistance center. Always use the same type spare parts.

- DO NOT touch any wire during operation as high voltage might be causing electric shock.

Warning:

- To prevent or reduce the risk of electrical shock or fire, do not expose the unit to rain or moisture.
- DO NOT open the unit within five minutes after switching off.
- The housing, the lenses, or the ultraviolet filter must be replaced if they are visibly damaged.

For 230V 50Hz power supply, maximum fixtures that can be connected on one power cable is 8;

For 120V 60Hz power supply, maximum fixtures that can be connected on one power cable is 4;

Caution:

There are no user serviceable parts inside the unit. DO NOT open the housing or attempt any repairs yourself. In the unlikely event your unit may require service, please contact your nearest dealer.

Installation:

The unit should be mounted via its screw holes on the bracket. Always ensure that the unit is firmly fixed to avoid vibration and slipping while operating. And make sure that the structure to which you are attaching the unit is secure and is able to support a weight of 10 times of the unit's weight. Also always use a safety cable that can hold 12 times of the weight of the unit when installing the fixture.

The equipment must be fixed by professionals. And it must be fixed at a place where is out of the touch of people and has no one pass by or under it.

2. Technical Specifications

- ◇ Compact design, fast and powerful LED moving beam wash
- ◇ DMX512 Control with 14 channels mode
- ◇ Perfect strobe with smooth dimming 0~100%
- ◇ Outstanding color macro effect
- ◇ Blue LCD display for easy navigation
- ◇ Low heat with long life span for fixture and LEDs
- ◇ Ideal for stage, theatre, TV studio, rental and discotheques

Input Voltage:	AC 100V~240V, 50/60Hz
Power Consumption:	198W
LED Sources:	OSRAM OSTAR RGBW 12 × 10W LED
Beam Angel:	10°~60°
Dimension:	263.3×183×340.4mm
Weight:	7.5Kgs

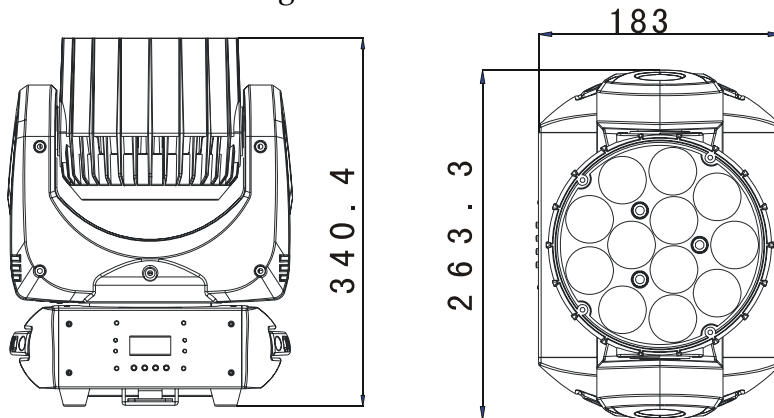

3. How To Set The Unit

3.1 Control panel

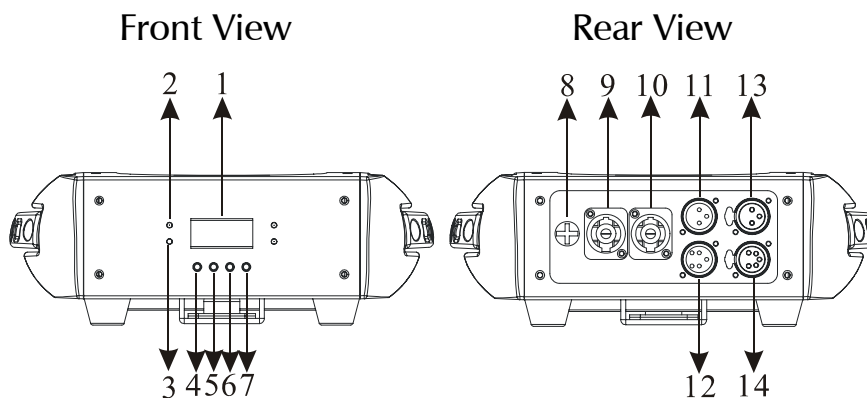

1. Display:

To show the various menus and the selected functions

LED:

2. POWER	On	Power On
3. DMX	On	DMX input present

Button:

4.MENU	To select the programming functions
5.DOWN	To go backward in the selected functions
6. UP	To go forward in the selected functions
7. ENTER	To confirm the selected functions

8. Fuse(T 6.3A):

Protect the unit from damage of the over-current.

9. POWERCON IN:

Connect to a socket (AC 100~240V, 50/60Hz) via the supplied mains cable.

10. POWERCON OUT:

Connect to supply power to the next unit.

11 DMX IN (3-pin XLR):

For DMX512 link, use 3-pin XLR cable to link the unit together.

12 DMX IN (5-pin XLR):

For DMX512 link, use 5-pin XLR cable to link the unit together.

13. DMX OUT (3-pin XLR):

For DMX512 link, use 3-pin XLR cable to link the next unit.

14. DMX OUT (5-pin XLR):

For DMX512 link, use 5-pin XLR cable to link the next unit.

3.2 Main Function

To select any of the given functions, press the **MENU** button up to when the required one is showing on the display. Select the function by the **ENTER** button and the display will blink. Use the **DOWN** and **UP** button to change the mode. Once the required mode has been selected, press the **ENTER** button to setup, to go back to the functions without any change press the **MENU** button again. Hold and press the **MENU** button about one second or wait for one minute to exit the menu mode.

The main functions are showing below:

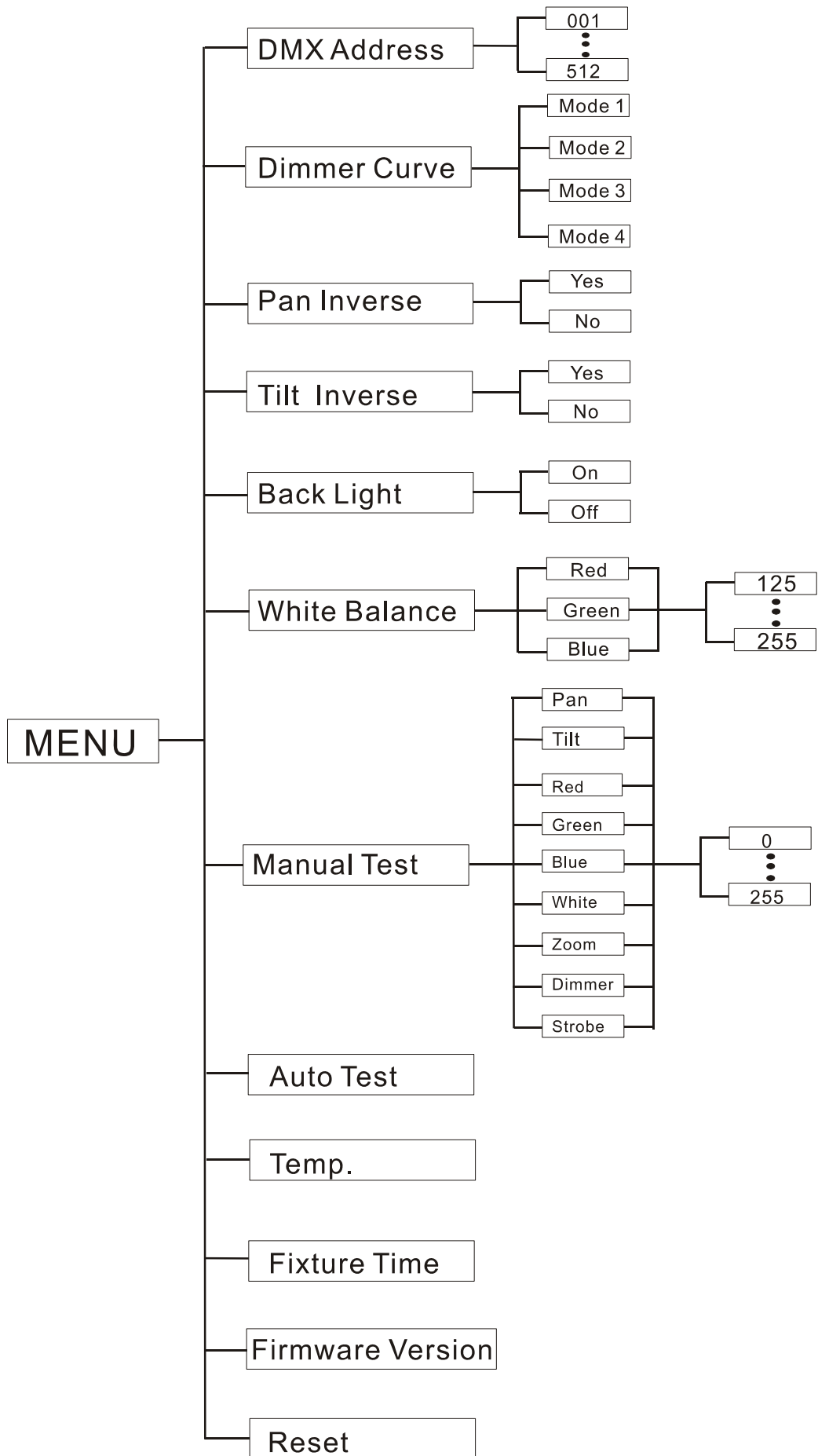

DMX Address

Select **DMX Address**, press the **ENTER** button to confirm, the present address will blink on the display. Use the **UP** and **DOWN** button to adjust the address from **1** to **512**. Once the address has been selected, press the **ENTER** button to setup, to go back to the functions without any change press the **MENU** button again. Hold and press the **MENU** button about one second or wait for one minute to exit the menu mode.

Dimmer curve

Select **Dimmer curve**, press the **ENTER** button to confirm, present mode will blink on the display. Use the **DOWN** and **UP** button to select the **Mode1**, **Mode 2**, **Mode 3** or **Mode 4** mode. Once the mode has been selected, press the **ENTER** button to setup, to go back to the functions without any change press the **MENU** button again. Hold and press the **MENU** button about one second or wait for one minute to exit the menu mode.

Dimmer Modes

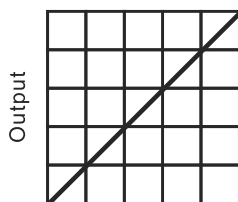

DMX %

Optically Linear

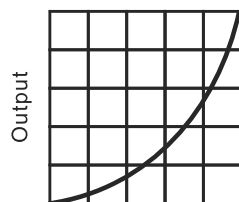

DMX %

Square Law

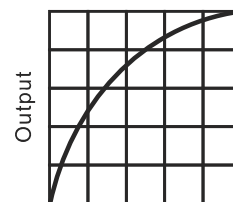

DMX %

Inverse Square Law

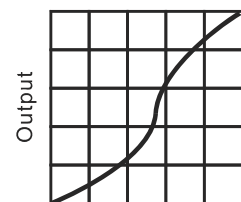

DMX %

S-curve

Mode 1 (Optically Linear): The increase in light intensity appears to be linear as DMX value is increased.

Mode 2 (Square Law): Light intensity control is finer at low levels and coarser at high levels.

Mode 3 (Inverse Square Law): Light intensity control is coarser at low levels and finer at high levels.

Mode 4 (S-curve): Light intensity control is finer at low levels and high levels and coarser at medium levels.

Pan Inverse

Select **Pan Inverse**, press the **ENTER** button to confirm, present mode will blink on the display. Use the **DOWN** and **UP** button to select the **Yes** (pan inversion) or **No** (normal) mode. Once the mode has been selected, press the **ENTER** button to setup, to go back to the functions without any change press the **MENU** button again. Hold and press the **MENU** button about one second or wait for one minute to exit the menu mode.

Tilt Inverse

Select **Tilt Inverse**, press the **ENTER** button to confirm, present mode will blink on the display. Use the **DOWN** and **UP** button to select the **Yes** (tilt inversion) or **No** (normal) mode. Once the mode has been selected, press the **ENTER** button to setup, to go back to the functions without any change press the **MENU** button again. Hold and press the **MENU** button about one second or wait for one minute to exit the menu mode.

Back Light

Select **Back Light**, press the **ENTER** button to confirm, present mode will blink on the display. Use the **DOWN** and **UP** button to select the **On** (LED on) or **Off** (LED off) mode. Once the mode has been selected, press the **ENTER** button to setup, to go back to the functions without any change press the **MENU** button again. Hold and press the **MENU** button about one second or wait for one minute to exit the menu mode.

White Balance

Select **White Balance**, press the **ENTER** button to confirm, present mode will blink on the display. Use the **DOWN** and **UP** button to select the **Red** or **Green, Blue**. Once the mode has been selected, press the **ENTER** button to setup, use the **DOWN** and **UP** button to adjust the value (125~255). Once selected, press the **ENTER** button to setup, go back to the functions without any change press the **MENU** button again. Hold and press the **MENU** button about one second or wait for one minute to exit the menu mode.

Manual Test

Select **Manual Test**, press the **ENTER** button to confirm, present mode will blink on the display. Use the **DOWN** and **UP** button to select the **Pan / Tilt / Red / Green / Blue / White / Zoom / Dimmer** or **Strobe**. Once you find a function or a color you wish to test, press the **ENTER** button, use the **DOWN** and **UP** button to adjust the values (0~255). Once finished the test, press the **ENTER** button to save, go back to the functions without any change press the **MENU** button again. Hold and press the **MENU** button about one second or wait for one minute to exit the menu mode.

Auto Test

Select **Auto Test**, press the **ENTER** button and the unit will run self-test by built-in program. To go back to the functions press the **MENU** button again. Hold and press the **MENU** button about one second or wait for one minute to exit the menu mode.

Temp.

Select **Temp.**, press the **ENTER** button and the display will show the temperature of the unit. To go back to the functions press the **MENU** button again. Hold and press the **MENU** button about one second or wait for one minute to exit the menu mode.

Fixture Time

Select **Fixture Time**, press the **ENTER** button and the display will show the number of working hours of the unit. To go back to the functions press the **MENU** button again. Hold and press the **MENU** button about one second or wait for one minute to exit the menu mode.

Firmware Version

Select **Firmware version**, press the **ENTER** button and the display will show the version of software of the unit. To go back to the functions press the **MENU** button again. Hold and press the **MENU** button about one second or wait for one minute to exit the menu mode.

Reset

Select **Reset**, press the **ENTER** button and all channels of the unit will return to their standard position.,

4. Control By Universal DMX Controller

4.1 DMX 512 Connection

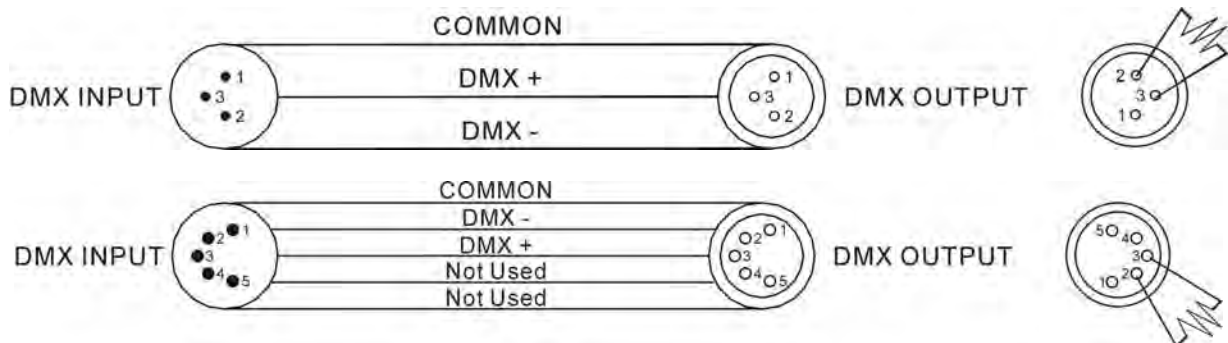
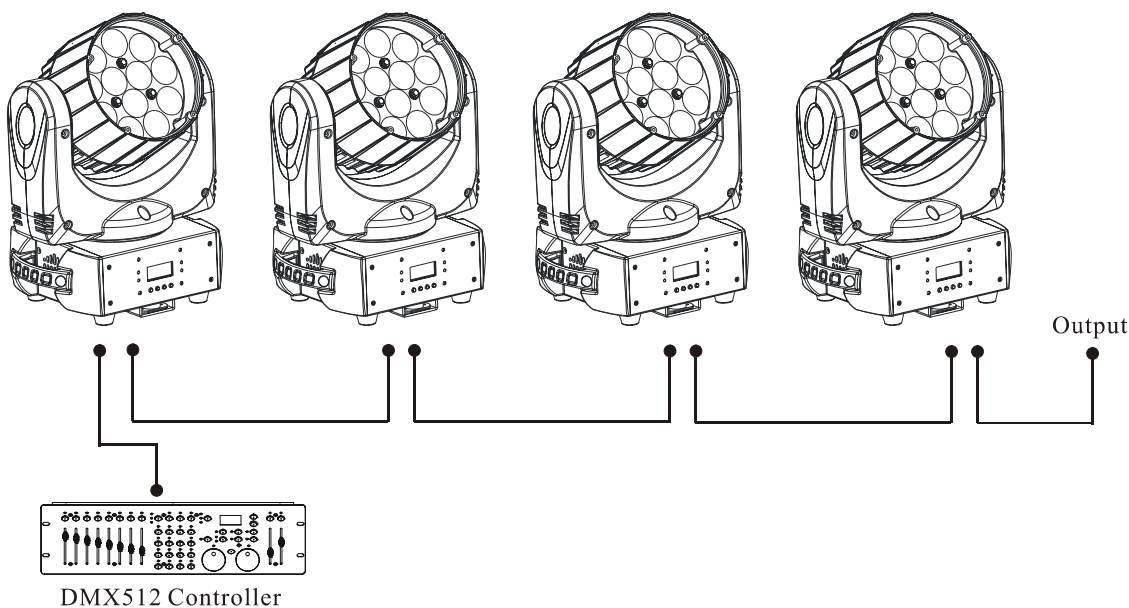

1. If you using a controller with 5 pins DMX output, you need to use a 5 to 3 pin adapter-cable.
2. At last unit, the DMX cable has to be terminated with a terminator. Solder a 120 ohm 1/4W resistor between pin 2(DMX-) and pin 3(DMX+) into a 3-pin XLR-plug and plug it in the DMX-output of the last unit.
3. Connect the unit together in a `daisy chain` by XLR plug from the output of the unit to the

input of the next unit. The cable can not be branched or split to a 'Y' cable. DMX 512 is a very high-speed signal. Inadequate or damaged cables, soldered joints or corroded connectors can easily distort the signal and shut down the system.

4. The DMX output and input connectors are pass-through to maintain the DMX circuit, when one of the units' power is disconnected.
5. Each lighting unit needs to have an address set to receive the data sent by the controller. The address number is between 0-511 (usually 0 & 1 are equal to 1).
6. The end of the DMX 512 system should be terminated to reduce signal errors.
7. 3 pin XLR connectors are more popular than 5 pin XLR.
 - 3 pin XLR: Pin 1: GND, Pin 2: Negative signal (-), Pin 3: Positive signal (+)
 - 5 pin XLR: Pin 1: GND, Pin 2: Negative signal (-), Pin 3: Positive signal (+)
 - Pin 4/Pin 5: Not used.

4.2 Address Setting

If you use a universal DMX controller to control the units, you have to set DMX address from 1 to 512 so that the units can receive DMX signal.

Press **MENU** button to enter menu mode, select the **DMX Address**, press **ENTER** button to confirm, the present address will blink on the display, use **UP** and **DOWN** button to adjust the address from 001 to 512, press the **ENTER** button to save. Press the **MENU** button back to the last menu or let the unit idle 7 seconds to exit menu mode.

Please refer to the following diagram to address your DMX512 channel for the first 4 units:

Channel mode	Unit 1 Address	Unit 2 Address	Unit 3 Address	Unit 4 Address
14 channels	1	15	29	43

4.3 DMX 512 Configuration

14 Channels Mode:

14 Channels						
Ch1	Ch2	Ch3	Ch4	Ch5	Ch6	Ch7
Pan	Pan Fine	Tilt	Tilt Fine	P/T Speed	Reset	Dimmer
<p>0 0° 255 540°</p>	<p>0 255</p>	<p>0 0° 255 220°</p>	<p>0 255</p>	<p>0 Fast 255 Slow</p>	<p>015-255 No function</p> <p>010-014 Reset all</p> <p>000-009 No function</p>	<p>0 0% 255 100%</p>
Ch8	Ch9	Ch10	Ch11	Ch12		
Shutter	Beam Red	Beam Green	Beam Blue	Beam White		
245-255 open 230-244 burst 225-229 open 210-224 sine wave 205-209 open 190-204 random burst pulse 185-189 open 170-184 burst pulse 165-169 open 150-164 random closing pulse 145-149 open 130-144 random opening pulse 125-129 open 110-124 random strobe 105-109 open 090-104 closing pulse 085-089 open 070-084 opening pulse 065-069 open 025-064 strobe 020-024 open 000-019 closed	<p>0 0% 255 100%</p>	<p>0 0% 255 100%</p>	<p>0 0% 255 100%</p>	<p>0 0% 255 100%</p>		

		Color wheel effect	
Ch 13	000-009	Open	
	010-014	LEE 790 - Moroccan pink	
	015-019	LEE 157 - pink	
	020-024	LEE 332 - Special rose pink	
	025-029	LEE 328 - Follies pink	
	030-034	LEE 345 - Fuchsia pink	
	035-039	LEE 194 - Surprise pink	
	040-044	LEE 181 - Congo blue	
	045-049	LEE 071 - Tokyo blue	
	050-054	LEE 120 - Deep blue	
	055-059	LEE 079 - Just blue	
	060-064	LEE 132 - Medium blue	
	065-069	LEE 200 - Double CT blue	
	070-074	LEE 161 - State blue	
	075-079	LEE 201 - Full CT blue	
	080-084	LEE 202 - Half CT blue	
	085-089	LEE 117 - Steel blue	
	090-094	LEE 353 - Lighter blue	
	095-099	LEE 118 - Light blue	
	100-104	LEE 116 - Medium blue green	
	105-109	LEE 124 - Dark green	
	110-114	LEE 139 - Primary green	
	115-119	LEE 089 - Moss green	
	120-124	LEE 122 - Fern green	
	125-129	LEE 738 - JAS green	
	130-134	LEE 088 - Lime green	
	135-139	LEE 100 - Spring yellow	
	140-144	LEE 104 - Deep amber	
	145-149	LEE 179 - Chrome orange	
	150-154	LEE 105 - Orange	
	155-159	LEE 021 - Gold amber	
	160-164	LEE 778 - Millennium gold	
	165-169	LEE 135 - Deep gold amber	
	170-174	LEE 164 - Flame red	
	175-179	Open	
		Color wheel rotation effect	
180-201	Clockwise, fast to slow		
202-207	Stop(this will stop wherever the color is at the time)		
208-229	Counter-clockwise, slow to fast		
230-234	Open		
		Random color	
235-239	Fast		
240-244	Medium		
245-249	Slow		
250-255	Open		
		Zoom	
Ch 14	000-255	 →  → 	

5. Troubleshooting

Following are a few common problems that may occur during operation. Here are some suggestions for easy troubleshooting:

A. The unit does not work, no light and the fan does not work

1. Check the connection of power and main fuse.
2. Measure the mains voltage on the main connector.
3. Check the power on LED.

B. Not responding to DMX controller

1. DMX LED should be on. If not, check DMX connectors, cables to see if link properly.
2. If the DMX LED is on and no response to the channel, check the address settings and DMX polarity.
3. If you have intermittent DMX signal problems, check the pins on connectors or on PCB of the unit or the previous one.
4. Try to use another DMX controller.
5. Check if the DMX cables run near or run alongside to high voltage cables that may cause damage or interference to DMX interface circuit.

C. Some units don't respond to the easy controller

1. You may have a break in the DMX cabling. Check the LED for the response of the master/slave mode signal.
2. Wrong DMX address in the unit. Set the proper address.

6. Fixture Cleaning

The cleaning of internal and external optical lenses and/or mirrors must be carried out periodically to optimize light output. Cleaning frequency depends on the environment in which the fixture operates: damp, smoky or particularly dirty surrounding can cause greater accumulation of dirt on the unit's optics.

- Clean with soft cloth using normal glass cleaning fluid.
- Always dry the parts carefully.
- Clean the external optics at least every 20 days. Clean the internal optics at least every 30/60 days.

Declaration of Conformity

We declare that our products (lighting equipments) comply with the following specification and bears CE mark in accordance with the provision of the Electromagnetic Compatibility (EMC) Directive 89/336/EEC.

EN55103-1: 2009 ; EN55103-2: 2009; EN62471: 2008;
EN61000-3-2: 2006 + A1:2009 + A2:2009; EN61000-3-3: 2008.

&

Harmonized Standard

EN 60598-1:2008 + All:2009; EN 60598-2-17:1989 + A2:1991; EN
62471:2008; EN 62493: 2010
Safety of household and similar electrical appliances
Part 1: General requirements



Litecraft[®]

PROFESSIONAL LIGHTING TECHNOLOGY

Litecraft is continuously developing and improving all its products. We reserve the right to change specifications without prior notification. Images are representing but not necessarily a precise product reference. Litecraft shall be under no liability for any loss, damage or injury for direct or indirect dependence on the information contained in this guide.

