

Gason Mowers & Slashers

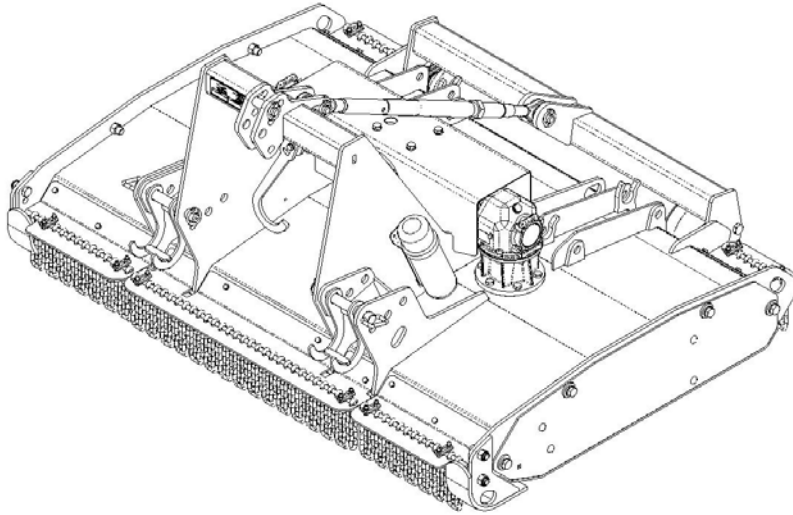

Operators Manual General

To be read in conjunction with model specific manual supplied

GPN 228903 REVISION A 06/12

COPYRIGHT

Neither this manual or part thereof may be reproduced or published
without the prior permission of A.F. Gason Pty. Ltd.

G
A
S
O
N



OH&S Compliance Certification

Company Name A.F. GASON PTY. LTD.

A hazard identification, risk assessment and risk control procedure has been carried out on a representative example of the under mentioned product(s) in accordance with the Occupational Health and Safety requirements of all states and territories of Australia and where found necessary the appropriate risk control measures have been incorporated in the product specifications.

The operator's manual contains the necessary health and safety information and safety warnings are applied to the product where necessary.

Product Description	Orchard/Vine Minder VHD Delta	VHD	Cropper/Proper
Topper			
Models No. or No.'s	OM3R & RP2R	15 & 20	VHD1R, 2R
	WL, PT2R		CT4R-WL, CT6R –

Signed on behalf of the above named company

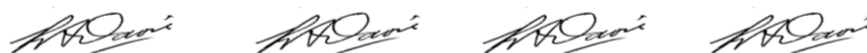

Name (printed)	Richard Davis	Richard Davis	Richard Davis	Richard Davis
Position	Quality Manager	Quality Manager	Quality Manager	Quality Manager
Date	17/11/2011	11/08/2010	16/08/2010	19/01/2011

Details of the Unit Assessed for the Purpose of Compliance

Model No.	OM3R2900-WD-SB	DELTA4600	VHD2R2910-3PL	CT6R10675-WL
Serial No.	225027-00002	223400-1013	224023-1010	224775-1010
Date of Inspection	17/11/2011	11/08/2010	16/08/2010	19/01/2011
Location of Inspection	ARARAT, VICTORIAARARAT, VICTORIAARARAT, VICTORIA ARARAT, VICTORIA			

VHD2R2400-SS
224378-1019
16/08/2010
ARARAT,VICTORIA



Contents

Contents

Introduction

Welcome	1
To The Dealer	1
About this Manual	1
To The Owner.....	2
Machine Record	2

Safety

Why is SAFETY so important?	4
Safety Alert Symbol.....	4
Signal Words	4
General Safety.....	5
Safety Rules & Accident Prevention	6

Assembly instructions

Unloading From Transport.....	8
Initial Assembly.....	8

Tractor Connection

3PL Connection	9
Trailed Connection.....	10
Attaching Driveline PTO Shaft.....	11
Clutch Set-Up	12
Set-up & Start-up	
Preparation Checklist.....	13
Start-Up Procedure	13
PTO Shutdown	13

Field Operation

Cutting Height Control	14
Setting the Skid Height.....	14
Operating Speed	14
Tractor Operating RPM	15
Turning with the Mower/Slasher.....	15
Rocks and Debris.....	15
Cutting Material and Conditions.....	15
Safety Chains & Covers	16
Rear Safety Guarding	16
PTO Cover Removal.....	16

Phasing Cylinders	16
Raising Wings	16
Wing Flotation	17
Cutting Angles.....	17
Blade Rotation	17
Rear Castor Wheel Kit.....	17
Single Castor Set-Up	18
Twin Castor Set Up.....	19
Rear Roller	19

Maintenance & Service

Before you Begin.....	20
8 Hours (Daily)	20
25 Hours (Weekly)	20
50 Hours.....	21
100 Hours.....	21
Annually	21
Safety Slip Clutch	22
Blades.....	22
Blade Hardware	22
Rotor Bars	22
Cleaning Machine	23
Torque Specifications.....	23
Maintenance Notes	23

Transportation

Road Travel	24
Machine storage	24

Troubleshooting

General Operation – Poor Cutting	26
Operation.....	27
Blades.....	28
Gearboxes	28
Driveline Clutches	29
Drivelines	29



Introduction

Welcome

A.F. Gason Pty Ltd (Gason) is an Australian owned family business operating from within rural Victoria. The Gason Company has been servicing the needs of rural Australians for more than 60 years. We operate through a local dealer support network that spans the country. Gason would like to thank you for purchasing your Australian made Mower/Slasher, and trust that you will have many years of trouble free service.

! Danger: Gason Mowers & Slashers are purpose built machines and have been specifically designed to suit their application. Any use of a machine outside of the intended purpose could result in Death or Serious injury to the operator or bystanders.

To The Dealer

Assembly and proper installation of this product is the responsibility of the Gason dealer.

The dealer and owner/operator must complete & sign the Installation and Warranty Registration Form included with this manual before releasing the mower to the new owner.

- Purchaser copy to be supplied to owner.
- Dealer copy to be retained by dealer
- Company copy to be returned to Gason.

In addition, the dealer must complete the Dealer Pre-Delivery & In-field Commissioning Check List included within this manual.

Gason ***strongly recommend a risk assessment*** be carried out prior to the machine being operated to ensure the operators fully understand the dangers involved in the operation of the Gason Mower or Slasher.

About this Manual

This manual endeavors to provide the owner with a complete understanding of the Mower/Slasher Safety, maintenance and operation including the processes required to obtain the highest level of performance possible.

! Caution: It is of the utmost importance that the owner/operator read this manual, and any other literature that has been supplied with your machine to ensure a safe and trouble free operation.

It should be noted that throughout this manual the Mower/Slasher may be shown without the guarding in place to provide a better view. The Mower/Slasher **must never** be operated without correctly fitted and adjusted guarding supplied with this machine.

References to the left and right hand sides of the Mowers/Slasher are from the rear of the machine looking forward in direction of travel as shown.



Introduction

To The Owner



Caution: Read & understand this manual before operating your Gason mower. The information presented will prepare you to operate your machine in a more efficient and safer manner.

This manual must stay with the Mower/Slasher in the 'waterproof holder' located on the headstock (3PL) or guarding (Trailed) of the unit. Replacement manuals are available upon request from Gason or online at www.gason.com.au. Replacement "holders" are available through your nearest dealer.

The manual includes an Installation and Warranty Registration Form which must be signed by the dealer & the owner/operator before releasing mower to owner.

- Purchaser copy of this form is to remain with the owner/operator.
- Dealer copy to be retained by dealer.
- Company copy to be returned to Gason.



Caution: Ensure you carry out, and keep up to date, a Risk Assessment. All operators must read the manual carefully and become acquainted with all the adjustments and operating procedures before attempting to operate.



Warning: Owner/Operator Acknowledgement sheet must be completed.

The Mower/Slasher you have purchased has been carefully engineered and manufactured to provide dependable and reliable use when operated and maintained in line with this manual. Like all mechanical products, it will require routine cleaning, upkeep and maintenance. Lubricate the mower as specified in this manual. Observe all safety information in this manual and obey all safety decals located on the machine.

Please be aware that in an effort to bring you the best products, Gason are always

implementing continuous improvements that may change the designs and specifications of the mowers & slashers. In doing this, Gason, together with its dealers and distributors, are under no obligation to implement such changes, free of charge, on any previously delivered mowers.

Machine Record

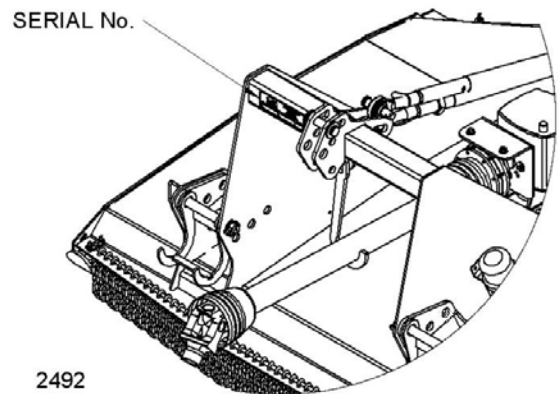

Serial No. Tag At Right Front Of Machine

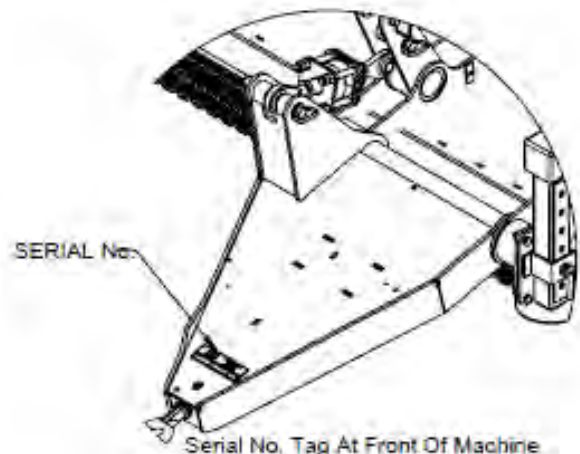

Serial Number: _____

Model: _____

Date Purchased: _____

Owner Name: _____

Owners Address: _____

PTO Speed 540 RPM 1000 RPM

Options Fitted: _____

Safety

Why is SAFETY so important?

The team at Gason rate operator Safety as one of the highest priorities when designing new features and machines. Every effort is taken to consider the end user and the risks they may face.

- Accidents can Disable & Kill
- Accidents are Costly
- Accidents Can be Avoided



The **Safety Alter Symbol** means:

**ATTENTION!
BECOME ALERT!
YOUR SAFETY IS INVOLVED!**

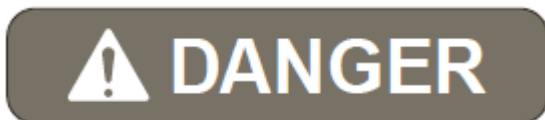

Safety Alert Symbol



The **Safety Alert Symbol** identifies important safety messages applied to the Mowers & Slashers in this manual. When you see this symbol, be alert to the possibility of **injury or death**. Follow the instructions provided on the safety messages.

Throughout this Manual the Safety Alert Symbol will be seen followed by one of the words.

Signal Words

DANGER: indicates an imminently hazardous situation that, if not avoided, **WILL** result in death or serious injury if proper precautions are not taken.

WARNING: Indicates a potentially hazardous situation that, if not avoided, **COULD** result in death or serious injury if proper precautions are not taken

CAUTION: Indicates a potentially hazardous situation that, if not avoided, **MAY** result in minor or moderate injury if proper precautions are not taken, or, serves as a reminder to follow appropriate safety practices.

Safety

General Safety

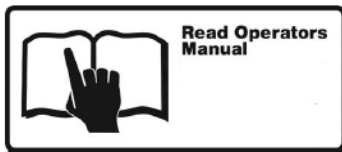

Whilst great care and every effort have been made by Gason to provide a machine to the highest possible safety standards, a Mower/Slasher by its nature is potentially dangerous.

In addition to the design and configuration of equipment, hazard control and accident prevention are dependent upon the awareness, concern, prudence and proper training of personnel involved in the operation, transport, maintenance and storage of equipment.

Be Prepared

In the event of an emergency it is best to be prepared. Gason recommend whilst operating the Mower/Slasher a fire extinguisher and first aid kit should be readily available in the event that they might be required.

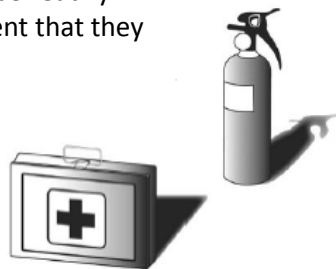

! Danger: Do not operate the tractor or Mower/Slasher until you have fully read and completely understand this operator's manual, your tractors operators manual, and all safety messages found within these manuals, on the products, or other included material.

! Caution: Mower/Slasher must always be operated in compliance with and applicable local council state and federal laws, regulations and codes of practice.

! Danger: Mower/Slasher should not be operated in close proximity to people of property. Objects ejected by mower may travel large distances and cause serious injury or death.

! Warning: When required to be operated in close proximity to people or property, the following must be addressed prior to operation of mower:

- All supplied guarding must be correctly adjusted.
- A risk assessment is conducted and appropriate control measures implemented to ensure all risks identified are eliminated or controlled
- Mower is fully inspected to ensure all functions are operating correctly

Personal Protective Equipment (PPE)

Gason recommends the following personal protective equipment be used when operating the mower/slasher.

- Safety glasses
- Hearing protection
- Gloves (when removing debris from rotors / decks)
- Breathing mask (dusty work environment)
- Sturdy Footwear.
- Figure hugging clothing.



Safe operation of the Gason Mowers & Slashers requires the full attention of the operator. Do not wear radio headphones, or talk on your mobile phone while operating these machines. Never operate while under the influence of alcohol or drugs or allow anyone under the influence to operate the tractor or Mower/Slasher.

Safety Decals

All Gason Mowers and Slashers are provided with a complete set of decals which include important safety information and are required to ensure the machine complies with the relevant work safe regulations. Every effort should be made to ensure the decals are legible at all times. Any decal which can be seen to be worn or can no longer be read should be replaced.

For a detailed list of Decals and their positions on the machines refer Parts Manual Supplied.

Safety

Safety Rules & Accident Prevention



• **Caution:** Customers **MUST** carry out their own Risk Assessment and/or "HazCheck" on every mower on their property.

• If you do not understand any part of this manual and need assistance please call either the dealer or Gason who will direct you to the appropriate training persons.



• **Warning:** Keep hands and body away from pressurized lines. Use paper or a rag to check for leaks, not hands or other body parts. Wear safety glasses to protect eyes. Hydraulic fluid (oil) under pressure can easily penetrate the skin and could cause serious injury or death.



• **Warning:** Ensure all operators and service personnel are aware that if hydraulic fluid (oil) penetrates the skin it will need to be surgically removed as soon as possible. Failure to do so may result in serious injury or death.

• Know your controls and how to stop the machine quickly in an emergency.

• Ensure all operators are properly instructed on the operation of the machine and position of controls. **Do not allow anyone to operate the machine without proper instruction.**



• **Caution:** Complete and sign owner/operator acknowledgement sheet.

• Do not allow children or untrained persons to operate equipment.

• Check that all hardware is tight and properly installed.

• Ensure Mower/Slasher is correctly attached, adjusted and in good working order before operating the machine.

• Ensure all spring activated locking pins or collars on the Power Take Off (PTO) shaft move freely, are well greased and properly seated in the tractor PTO splined angular groove.



• **Caution:** Prior to operating the machine check all equipment driveline guarding for damage and ensure it rotates freely. Replace

any damaged or non rotating guarding before any further operation.



• **Caution:** Check chains, shackles, deflectors and any other wearing part for damage daily. Replace any damaged parts before operation.

• Remove any debris that has accumulated on the Mower/Slasher, tractor to avoid fire hazard.



• **Caution:** Ensure all guards and shields are properly fitted and in good working order. Replace any damaged or worn guards, failure to do so may cause serious injury or death.

• Do not operate Mower/Slasher unless side skids are in good working condition. Replace if damaged.

• Watch for hidden hazards on the terrain and remove any hazards or objects that may cause injury or damage.



Danger: **NEVER** Discharge toward people, animals or property.

• Keep all people and animals away from the mower during start-up, operation, when stopping, maintaining or adjusting.

• Be aware that it may be necessary to Disconnect the PTO when raising the Slasher/Mower above working height.

• Operate only in daylight or good artificial light.



Caution: Keep hands, feet, hair and clothing away from moving parts when working on Mower/Slasher.

Safety

- Do Not carry persons or objects on the mower or tractor during work or while in transit.

- For transportation on public roads the operator must ensure that the tractor and Mower/Slasher complies with current state and federal laws and must strictly adhere to all road traffic regulations in force in his/her particular state.

- Operate tractor at the specified PTO speed. Always ensure the correct PTO setting on your tractor before start-up.

- Do Not operate tractor PTO during transport.

- Use Extreme care and reduce ground speed on slopes and rough terrain.



- **Warning:** Do Not stop, start or change direction suddenly on steep slopes. Working up and down slopes is recommended.



- **Caution:** Stop mower, then tractor, immediately upon striking an obstruction. Turn off engine, remove key, inspect and repair any damage before resuming operations. Always block or lower mower to the ground when inspecting.



- **Danger:** Before commencing any adjustment, maintenance, or cleaning, always disengage the PTO shaft, switch off the tractor engine, remove key and wait until all moving parts have come to a complete stop. Then ensure the machine is lowered onto flat

ground or supported in a secure elevated position.



- **Caution:** Before dismounting tractor or performing any service or maintenance, disengage Power to mower, lower the 3PL and any other raised components to the ground. Operate valve levers to release any hydraulic pressure, stop engine, set parking brake and remove key.



- **Danger:** Never place any part of the body underneath the mower or between moveable parts even when

engine has been turned off without first fitting safety stands. Hydraulic systems can “creep” (i.e. slowly lower). Any movement of the control levers can cause the mower to drop or move unexpectedly causing severe injury or death.

- For your own safety and that of others and to avoid forfeiting your warranty, use only original spare parts.

- Do Not Modify/Alter or permit anyone else to Modify/Alter the mower or any of its components.

- Do Not handle blades with bare hands. Careless or improper handling may result in serious injury.

- Gason accepts no responsibility or liability for any losses, injuries or damages that may result from failing to observe these safety rules and the safety decals on the Mower/Slasher.

Tractor Connection

Unloading From Transport

Lifting Machine

Machines can be lifted with approved overhead lift gear or forklift pick up. Use machine lift and tie down areas for safe manoeuvring as shown below. Locations of lifting points vary between models but all are equipped with similar lifting points to those shown below.

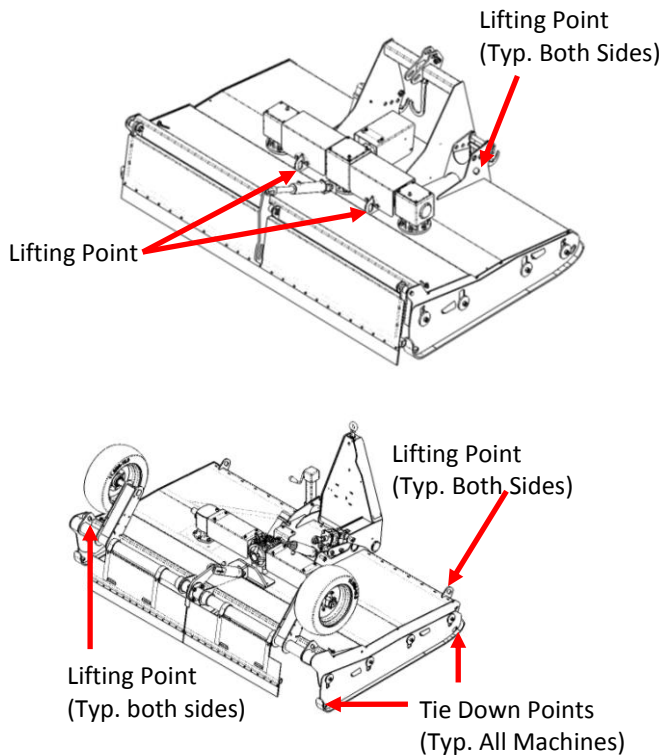

It is recommended to sit machine on rubber/timber non slip pads when transporting on steel trays. Use machine tie down points located on adjustable skids to secure machine to transport surface. Do not move transport vehicle until machine is secured to tray.



Caution: Do not over tighten at tie down points, to avoid permanently deforming skids.

Forklift Handling

Exercise care whilst moving machine by forklift or other means, machine may become unstable when carried by forklift.

Larger machines may require forklift tine extensions fitted for safe handling. Forklifts are best suited for handling machines, pick up from headstock/linkage side of machine. Be aware of blade rotors when positioning fork tines under body, to avoid damage to blades and or rotors.

Initial Assembly

Set up instructions detailed as follows are a guide only.

Most machines are dispatched from the factory with some components requiring attachment and/or assembly.

The Main items of assembly in most cases will be;

1. PTO shaft to be unattached from shipping position (cut cable ties), tube greased and fitted to fastened shaft.
2. Trailing wheels moved into correct working position. (Trailed unit only)
3. Rear castor wheels moved into correct working position or attached. (3PL unit only)

Gason suggest that you carry out all assembly processes on flat level ground.

Only personnel involved with the assembly of machine are to be present. Ensure the general public are kept clear at all times.

PTO Shaft Removal (when required)

The front PTO shaft shipped with new Mowers & Slashers may require cutting to length prior to fitment of full PTO shaft to tractor, refer to "Tractor Connection" section of this manual for details.

The PTO shaft on 3PL models will normally be fastened by nylon strap or cable ties to retaining hooks located on the lower 3PL pins. Use a sharp blade to cut nylon strap to allow removal of

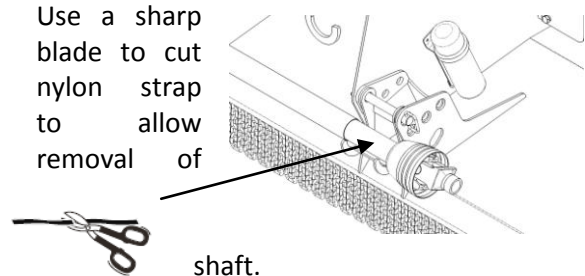

For trailed machines the PTO can be found either attached to the machine above the guards or shipped with the machine on the pallet.

Tractor Connection

Lubricate PTO sliding shaft inner with general purpose grease.

! Caution: avoid sharp edges that may be present from prior cutting of PTO shaft tube.

Trailing Wheels

In some cases the trailing wheels may not be set in the correct working position to allow the unit to be compacted for shipping.

To set wheels in correct position for working simply undo crank bolts, remove and rotate crank into correct position and tighten to correct torque as seen in Torque specification section of this manual.

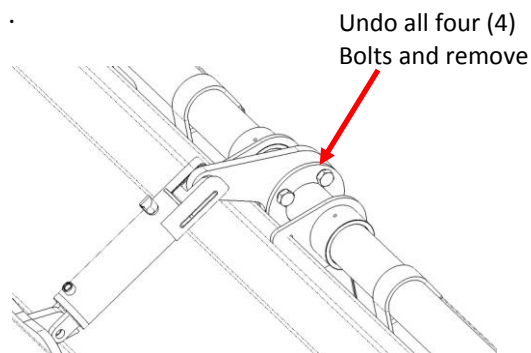

Rear Castor Wheel (when fitted)

The castor wheel assembly will not be adjusted for field use, rather it will be shipped in some cases separate to the mower/slasher or in its transport position.

If the Rear Castor Wheel Kit is shipped separate it will be necessary to attach it to the mower using the supplied eight (8) bolts.

! Caution: The Rear Wheel Kits are heavy and will require lifting equipment to be fitted. Do not attempt to lift without the aid of lifting equipment.

Once fitted (or if supplied fitted) it will be necessary to adjust the main screw bar to 'push' wheels to the ground.

Refer to "Field Operation" section of this manual for details on setting the Rear Castor assembly for operation.

3PL Connection

Gason suggest that you carry out all assembly processes on level and stable ground.

! Caution: Only personnel involved with the connection of machine to tractor are to be present, instruct general public to keep clear at all times. When tractor is not being operated ensure key is removed from ignition.

Assess tractor 3PL compatibility to Mower/Slasher 3PL.

Gason 3PL mowers and slashers are supplied with cat 2 pins (or cat 3 pins, when ordered).

Note: Ensure all components on tractor 3PL are in good working order; sway arm adjusters operate correctly, top link adjuster arm is serviceable, not bent or seized and is fitted with lock nut to secure adjustment setting. Mower/Slasher cannot be set up correctly if tractor 3PL is not in serviceable condition.

If tractor 3PL is fitted with quick hitch attachment it is recommended to mount the 'Quick Hitch Balls' to top and bottom linkage pins prior to reversing tractor to the Mower/Slasher.



1. Loosen tractor lower sway arm adjustment, reverse tractor to Mower/Slasher and ensure any Personnel are clear of tractor when reversing to machine.

Tractor Connection

2. Engage tractor lower sway arms to Mower/Slasher lower linkage pins.
3. Fitment of pipe sleeves is recommended to minimize side movement.
4. Ensure lynch pin is engaged and secure to contain linkage pin.
5. When arms are engaged and secured, turn off tractor.
6. Fit top link adjuster bar to top linkage connection, for standard connection, pin to fixed hole, for extra float and special operation with twin rear castor wheel assembly the float slot can be selected.
7. Start tractor and lift the Mower/Slasher slightly clear of the ground.
8. Centralize the Mower/Slasher and adjust the lower linkage sway arms to tight, ensuring the lower linkage balls are tight against the Mower/Slasher linkage plates.

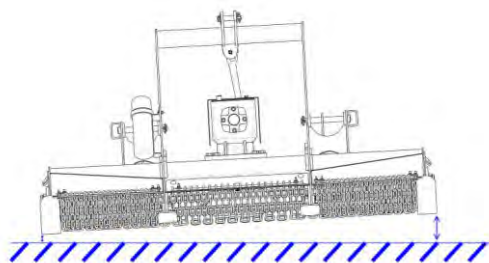
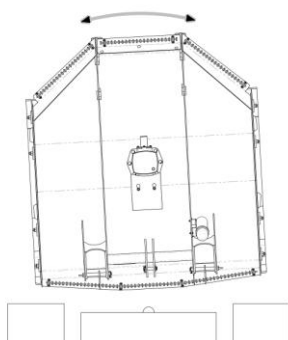

9. Adjust Top link adjuster bar to set cut angle of the mower/slasher. Best cut results are achieved with the front of the mower slightly lower than the back.

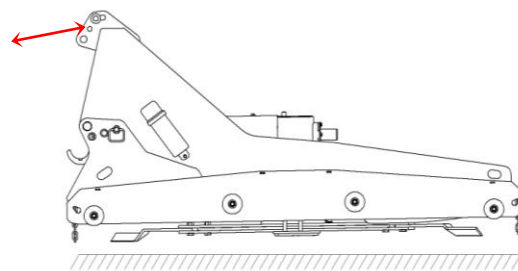

10. Where required connect hydraulic hoses to remotes on tractor.

Trailed Connection

Gason suggest that you carry out all assembly processes on level and stable ground.



Caution: Only personnel involved with the connection of machine to tractor are to be present, instruct general public to keep clear at all times. When tractor is not being operated ensure key is removed from ignition.

Gason trailed mowers and slashers are supplied with cat 3 pins (cat 4 pins available on some units).

1. With the Mower/Slashers resting on a flat level surface, reverse the tractor to the drawbar, park tractor with minimal clearance between tractor tow tongue and drawbar.
2. Wind compression adjuster to allow drawbar connection and once done back up tractor. Ensure tow bar pin is installed with an appropriate retaining pin/clip fitted.
3. Install a suitably rated safety chain from drawbar to tractor tow bar (Supplied with machine). A shackle attachment point is located near the front of the drawbar.
4. Attach body lift hydraulic hoses to appropriate tractor hydraulic remotes (ensure couplings are clean and not damaged). Check machine hydraulic actuation responds to desired lever/control movement, i.e. pull lever back to raise machine, push lever forward to lower machine.



Caution: do not inadvertently drive tractor away from machine with hydraulic hoses connected.

Tractor Connection

Hydraulic hoses are tagged for correct pairs using tags as shown below



GPN:227170



GPN:227171



5. Manually adjust compression adjuster link, extending its length to allow drawbar to pressure down on tractor tow bar, apply pressure

by hand only until tight. It is important that the machine

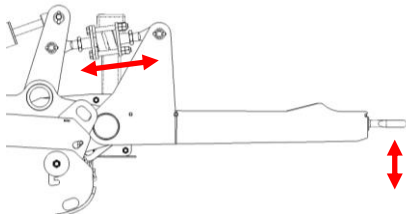

be on level ground for this set up stage, if setup is carried out on uneven ground further adjustments will be required later

6. Tractor hydraulics can now raise or lower the drawbar to allow tractor to lift machine.

7. Further adjustment of compression adjuster may be required to allow for level body lift.

Attaching Driveline PTO Shaft

In most instances the front PTO shaft may require cutting to correct length to match operating tractor.



Danger: Shut off tractor engine before attaching PTO driveline. Entanglement in rotating driveline can cause serious injury or death.

1. Connect Mower/Slasher to tractor as detailed above.
2. With PTO shaft separated, connect the tractor mounting $\frac{1}{2}$ shaft to tractor power take off spline and rest shaft on machine deck.
3. Remove safety covers from the PTO shafts and set aside.
4. With a marking pen at hand, hold both steel $\frac{1}{2}$ shafts against each other and mark / measure a point approximately 100mm back from the end of the yolk and mark the steel tube at the measured point on the aside tube. (refer fig below)



5. Mark both shafts as detailed above and using a suitable cutting device, remove excess shaft length.

Caution: Wear appropriate safety equipment, i.e. safety glasses, ear protection if using power assisted cutting tools.

6. Remove all sharp edges with file.
7. PTO safety covers are to be cut 40mm shorter than steel tube length, this allows easy fitment of shafts together.
8. Refit safety covers and connect to tractor, start tractor and with caution raise and lower mower/Slasher checking PTO shaft clearance, re-cut PTO shaft if not enough travel.

Tractor Connection

Clutch Set-Up

The clutch provides overload protection of all driveline components, including gearboxes, by slipping when excessive torque loads are encountered.

Warning: Prolonged use of incorrectly set clutch may result in premature wear or damage to all driveline components.

Whilst clutch fitted is factory pre-set, variations in condition, type of material cut, size of tractor, terrain, etc determines that clutch performance must be continuously monitored and reset as required.

Correct clutch setting will result in a clean consistent cut with no observable reduction in tractor performance.

A general guide to setting the clutch is to fully tighten all nuts and then back off 2 complete turns for heavy slashing and 2.5-3 turns for lighters going.



Caution: *Ensure springs are evenly adjusted, failure to do so may result in premature failure. Measure spring length to confirm.*

To Adjust:-

- Turn off Tractor
- With correct size spanners, evenly tighten or loosen compression spring bolts and nuts

NB: ¼ to ½ Turn may make a significant difference.

To check if clutch is set correct Gason recommend the use of a digital thermometer.

Check the temperature of the clutch after 20min operation. The clutch should be slightly above ambient temperature.

To cold and the clutch isn't set tight enough.

To hot and the clutch is set to tight.



Caution: *Contact With hot clutches may result in serious injury. Gason recommend exercising caution when checking temperature.*

Set-up & Start-up

Preparation Checklist

- Read and understand the operator's manual and all safety decals

NB: Refer Owner/Operator Acknowledgement sheet.

- Check all Safety Guarding is fitted, adjusted correctly and in good condition.
- Grease all recommended greasing points.
- Check oil levels in gearboxes.
- Inspect all tyres (where applicable) are in good working condition.
- Inspect all blades, rotors and hardware is in good working condition.
- Ensure Clutch and PTO has been properly adjusted to suit tractor.

Start-Up Procedure

1. Attach machine to tractor as detailed earlier.
2. Using tractor 3PL or Hydraulics, lift machine 100mm clear of ground.
3. Adjust 3PL sway arm level/vertical adjustments to ensure machine is centered and is in a level carry position. Adjust Compression Link on Trailed unit to achieve same result.
4. Lower machine to ground.
5. Fit PTO shaft to tractor and ensure holding pins are engaged and shaft will not come off in operation.
6. Set adjustable side plates to reflect required cutting height and lower machine to ground.
7. Start tractor and cautiously raise Mower/Slasher to check clearance of PTO shaft and Mower/Slasher deck, should PTO potentially contact the front of machine deck, set linkage lift 'stop' with safe clearance. The machine should only be raised sufficient to clear the ground for safe travel and maneuvering.

Caution: Prior to start up; clear all personnel from the area immediate to the machine.

8. Ensure no loose debris is under the machine.
9. Start tractor and with tractor engine revs above idle engage PTO drive, increase tractor revs to specified PTO operating RPM.
10. Run machine long enough to assess operating performance, i.e. no unusual noise, vibrations, etc. Should a problem be noticed, immediately shut down tractor and lower machine to ground. Turn off tractor, remove key and when blades have ceased rotation alight tractor and investigate.

PTO Shutdown

1. Reduce engine revs, disengage PTO drive and SHUT DOWN TRACTOR.



Caution: Most Gason mowers & slashers are fitted with over run clutches/devices, Machine will continue to wind down for several minutes after tractor PTO has been disengaged.

General Field Operation

IMPORTANT WARNING NOTICE

TO THE OWNER/OPERATOR/DEALER
THE MOWER/SLASHERS ARE PURPOSE SPECIFIC MACHINES DESIGNED TO
SUIT A SPECIFIC APPLICATION.
TO FACILITATE THIS ACTION THE UNIT MUST BE HEIGHT SET FOR A CLEAR
INTAKE AND DISCHARGE.

Cutting Height Control

Correct cutting height should be set in the field to suit field conditions by tractor 3PL control or depth stops on trailed units.

To set cutting height, raise machine to a cutting height deemed suitable for the forecasted work load.



Warning: Do not allow personnel to get under machine to measure blade to ground dimension.

With machine raised to preferred cutting height, set tractor 3PL controls and/or adjust castor wheel assembly to correct setting for a 3PL unit. Ensure minimum clearance of 12mm between bottom of skids and ground.

For Trailed unit, raise machine to desired cutting height using tractor hydraulics. Set depth stop located on master cylinder to desired height and adjust compression adjuster link as required. (Refer Trailed Connection Section of this manual.)

Depth Control



Setting the Skid Height

Most Gason Mowers/Slashers are fitted with height adjustable sides of 8mm plate and equipped with 100 x 12mm hardened steel

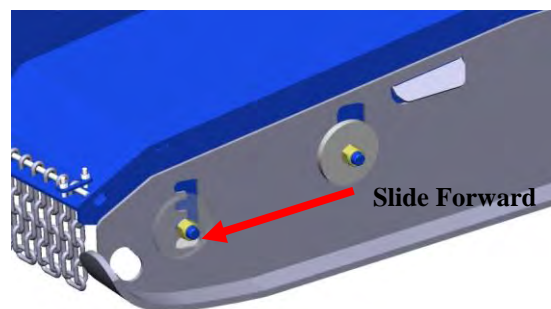

To adjust height settings in general:

1. Loosen off retaining nuts.
2. Using the hand-grips, slide side forward.
3. Raise or lower to the required setting and slide back, engaging into the "Lock & Dog" slot.
4. Ensure skids are set to the same height.
5. Tighten all nuts.

Skids should be set to a minimum 12mm from ground, too low and premature wear of the hardened steel skids could result.

Operating Speed

Operating speed is determined by ground conditions, tractor hp, grass conditions and application of the mower/slasher. Field experience indicates optimal operating speeds of 8 to 15 kph as a general guide.

Gason Mowers & Slashers recommends commencing cutting operation at low speed, then steadily increasing speed. The operator should be observant of the machines cutting performance at all times at this stage including the PTO shaft clutch operation. Refer "Clutch Set-up" section of this manual.

General Field Operation

Tractor Operating RPM

The Mower/Slashers are rated to 540 or 1000 PTO, Body mounted identification sticker and serial number tag indicates PTO speed requirements.



For the Mower/Slasher to provide best performance Gason Mowers & Slashers recommends operating the machine at the recommended maximum PTO speed.

Warning: Operating above Recommended PTO Speed may result in premature wear and Void Warranty.

Should grass conditions be light and less demanding on cutting performance PTO rpm may be reduced to a lower PTO rpm however cut performance should always be closely monitored.

Turning with the Mower/Slasher

Gason Mowers & Slashers recommends that the Mower/Slasher be raised to safely clear the ground when undertaking tight turns.

Turning without raising Mower/Slasher may cause material (soil) to build up, applying pressure to the sides (the side will act as a grader blade), in extreme conditions this pressure will affect the alignment of the re-enforced sides.

The Operator should also exercise caution when turning in large arc's observing the machines progress and clearance to ground, immediately lift the machine should soil damage commence.

Rocks and Debris

Caution: Mower/Slasher is not designed to engage rocks or the ground.

The Mower/Slasher driveline is protected by the main input clutch assembly, this system is designed to absorb minor over loads and events. The clutch should be regularly checked and set to slip in the event of a major overload.

Contractors should discuss ground conditions with the property owner/manager to highlight potential risks on the property before commencing contracted work tasks.

Warning: Be aware that the machine can discharge rocks and debris with velocity, set cutting height to keep machine clear of rough ground conditions.

Warning: Be aware of fallen tree branches and tree stumps or similar; keep machine cutting operation clear of trees/scrub/nature belts.

Warning: Be aware to operate a safe distance from fence line, stray/fallen fence posts and loose wire are a risk for the Mower/Slasher.

Warning: Be aware of any low profile implements/structures i.e. harrows, laying in stubble, mark positions or remove from paddock before cutting.

Cutting Material and Conditions

Green cutting operations may require higher tractor horsepower; operating ground speeds may be considerably slower than for dry material.

Do not attempt to cut lower than 50mm from ground with green cutting operations.

Caution: Cutting low to the ground will also require higher tractor horsepower as well as increasing the potential for ground scalping and hitting foreign material / objects.

Should conditions be too heavy it will be necessary to raise the cutting height to reduce the load on the rotors.

General Field Operation

Safety Chains & Covers

Always ensure chains are in good working order, repair or replace worn/damaged or lost chain links.

Safety covers are in place for operator safety as required by Occupational Health Safety and Welfare regulations. Replace covers after service or repair work or if not in serviceable condition.



Warning: Failure to replace safety covers could result in death or serious injury.

Rear Safety Guarding

Gason Mowers/Slashers are required to be fitted with rear guarding in certain applications to ensure the safety of the operator and bystanders. Removal of any safety guarding on a Gason Mower/Slasher will void all warranties.

PTO Cover Removal

Gason use two different types of PTO's depending upon the machine and application. The below shows how to remove the covers for the Italian Comer PTO covers.

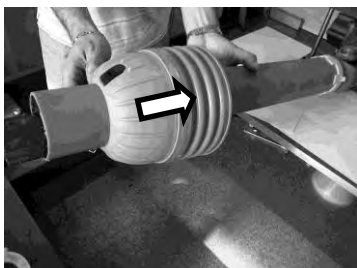

Thread the cas1025 h



Turn the casing to phase it



Push powerfully to hook it

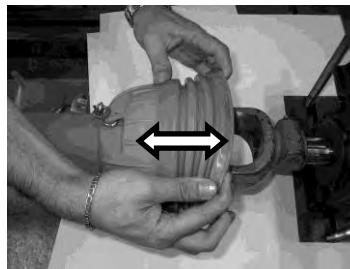

Check if the casing is hooked
For a detailed view on how to use the bareco PTO cover system visit the following.
<http://bareco.com.au/files/movieindex.htm>

Phasing Cylinders

Gason trailed mowers and slashers are fitted with a hydraulic phasing system used to synchronize the raising and lowering of the mower/slasher.

This system may require re-phasing from time to time to ensure the continued synchronized lift.

To Re-Phase cylinders fully extend lift cylinders and hold the circuit open for a short period of time (approx 2 mins) allowing cylinders to re synchronize.

Raising Wings

Gason wing lift machines are fitted with double acting lift cylinders which include counter balance valves preventing the unit from dropping unexpectedly when the wings are folded.

Counter Balance valves are pre set such that, should the hydraulics fail on the machine during the wing lift process, the wings will slowly creep back to ground.



Caution: Ensure all bystanders are clear when lifting & lowering wings.



Warning: Gason recommend only lifting the wings when situated on level and stable ground. Lifting the wings on an incline may cause Machine instability and result in the machine tipping.

General Field Operation

! Danger: Ensure PTO is shut off and rotating has ceased prior to lifting wings to prevent bodily injury or death from thrown objects or rotating blade as well as damage to PTO driveline components.

Wing Flotation

It is recommended to run both wings (where applicable) in the float position. This allows the cylinder to be free to extend or retract enabling the machine to follow the ground contour.

! Caution: Failure to run Mower/Slasher in float for extended periods may result in premature wear of ram pins and connection points.

Cutting Angles



The below table specifies the suggested maximum working angles for the various winged machines.

Machine	A °	B °
Orchard Mower	0	10
Delta Wing	20	45
Cropper Topper	4	4

! Danger: Gason Delta Wing Slashers can operate throughout the entire wing lift range. Gason recommend the Delta wing only be operated to a maximum of 45° for the safety of the operator and bystanders ensuring that the wing rear trailing wheels are on constant contact with the ground.

Rotorbar Timing

All Multiple Rotor Gason built units are timed 90° apart such that the rotors don't hit in operation. When replacing PTO's or gearboxes it is imperative that the unit be timed the way it was purchased.

Blade Rotation

The Diagram Below shows the Blade direction for the various machines as viewed from above the machine.

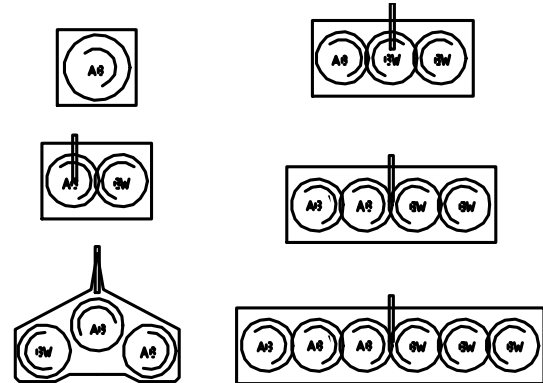

! Caution: Ensure correct blade rotation when changing blades. Failure to do so may result in the mower/slasher not cutting correctly.

Rear Castor Wheel Kit

The rear castor wheel assembly is an optional extra available in both single wheel (6ft VHD only) and twin wheel configurations and is fitted to rear of 3PL mower/slasher decks to provide stable cutting platform.

The castor operation is by parallelogram kingpin alignment, which allows for forward and reverse slashing operation with minimal alteration to cutting height.

Cutting height adjustment is by a screw bar adjuster.

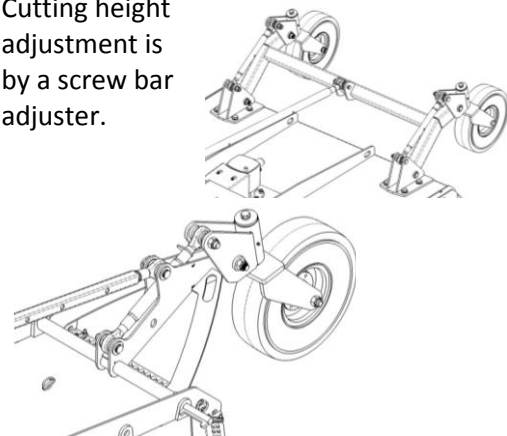

General Field Operation

King Pin alignment

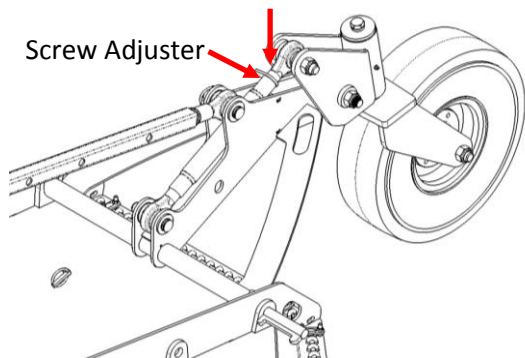

It is important to maintain symmetrical alignment between castor wheels when using twin wheel and to ensure king pin is perpendicular to the ground on both configurations. Visually check alignment and adjust screw adjusters to match each side as required.

Lock off adjuster nut/s to securely fasten settings.

Single Castor Set-Up

1. With the VHD Slasher attached to tractor 3PL on flat, level firm ground and height adjustable sides set for required cutting height proceed as follows;
2. Screw bar adjuster is to be fitted to fixed hole (float slot can be used by trained operators requiring extra float action for special occasions).
3. Wind Castor wheel 'Headstock – Wheel Frame' adjuster bar to push wheels to firm ground contact.
4. Raise tractor 3PL to lift VHD Slasher to anticipated cutting height.
5. Again, wind Castor wheel 'Headstock – Wheel Frame' adjuster bar to push wheels to firm ground contact.
6. Raise tractor 3PL slightly to allow 'Top Link Adjuster Bar' to be extended until turning becomes firm.
7. Lower tractor 3PL to 'Full Detent' or 'Float' and check cutting height clearance.
8. Adjust King Pin alignment to ensure King Pin is perpendicular to ground.
9. Continue action 6, 7 & 8 until correct cutting height / skid clearance is set when

'Full Detent' or 'Float' has the machine at correct level.

Adjustment

The Single Rotor 6ft and 8ft Twin rotor VHD's have been designed to accommodate a 2 position rear Wheel kit with the option of moving the rear caster closer to the main body as shown below.

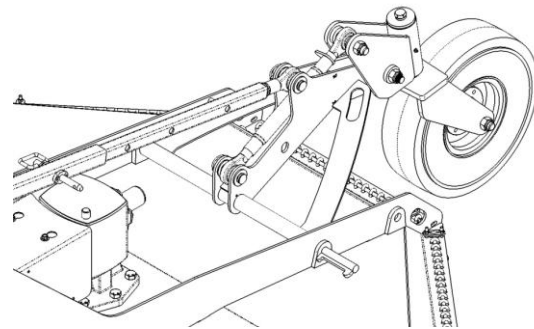

Caution: In this position the castor will not be able to rotate 360° thus the mower should not be used in reverse. However for the operator requiring a shorter mower for transport and continued forward transport this position provides this option.

The Adjustable Top Link has been designed to accommodate easy transition from one position to the other and has the ability to slide freely once the pin is removed. The below image is a guide for the pin position when in the different mountings.

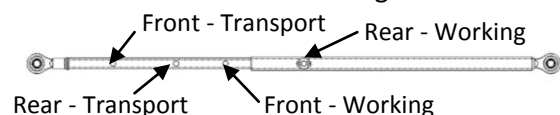

General Field Operation

Twin Castor Set Up

1. With the VHD Slasher attached to tractor 3PL on flat, level firm ground and height adjustable sides set for required cutting height proceed as follows;
2. Screw bar adjuster is to be fitted to fixed hole (float slot can be used by trained operators requiring extra float action for special occasions).
3. Wind Castor wheel 'Headstock – Wheel Frame' adjuster bar to push wheels to firm ground contact.
4. Raise tractor 3PL to lift VHD Slasher to anticipated cutting height.
5. Again, wind Castor wheel 'Headstock – Wheel Frame' adjuster bar to push wheels to firm ground contact.
6. Raise tractor 3PL slightly to allow 'Top Link Adjuster Bar' to be extended until turning becomes firm.
7. Lower tractor 3PL to 'Full Detent' or 'Float' and check cutting height clearance.
8. Adjust King Pin alignment to ensure Kin Pin is perpendicular to ground.
9. Continue action 7 & 8 until correct cutting height / skid clearance is set when 'Full Detent' or 'Float' has the machine at correct level.

Adjustment

The twin castor rear wheel kits are single position rear wheel kits which are simply adjusted by a screw bar top link extending from the headstock back to the rear wheel frame. To adjust screw link, twist to either extend length or shorten.

Rear Roller

Note: This option is only available on the 6ft VHD Slasher & Rapier/Orchard Mowers.

Set-Up

1. With the VHD Slasher attached to tractor 3PL on flat, level ground and height adjustable sides set for required cutting height proceed as follows;
2. Screw bar adjuster is to be fitted to fixed hole (float slot can be used by trained operators requiring extra float action for special occasions).
3. Wind Roller 'Headstock – Roller Frame' adjuster bar to push roller to firm ground contact.
4. Raise tractor 3PL to lift VHD Slasher to anticipated cutting height.
5. Again, wind roller 'Headstock – Roller Frame' adjuster bar to push roller to firm ground contact.
6. Raise tractor 3PL slightly to allow 'Top Link Adjuster Bar' to be extended until turning becomes firm.
7. Lower tractor 3PL to 'Full Detent' or 'Float' and check cutting height clearance.
8. Continue action 7 & 8 until correct cutting height / skid clearance is set when 'Full Detent' or 'Float' has the machine at correct level.

Adjustable Link

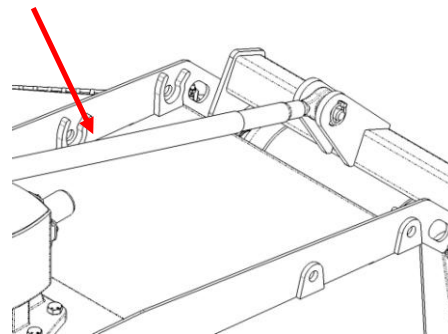

Maintenance & Service

Before you Begin

Gason recommend all service personnel read the Safety Rules & Accident Prevention section of this manual.

It is also suggested that the following be completed prior to beginning any service or maintenance on the Mower/Slasher.

1. Park Tractor and Mower/Slasher on flat level ground
2. Disengage the PTO
3. Shut off tractor engine and remove ignition key
4. Relieve pressure in hydraulic lines.
5. Ensure all moving parts have stopped, then remove PTO driveline from tractor.
6. Place approved safety stands in secure locations under centre body and wing section, NOT under axles or wheel supports.



Danger: Failure to understand the dangers involved in the product being serviced may result in death or serious injury.

8 Hours (Daily)

- Fully inspect all rotor bars and blades for chips, cracks, wear marks and abnormal bends.
- Danger:** Damaged blades can result in serious injury or death.
- Fully inspect all blade hardware and ensure they are properly tightened and secured
 - Check the tightness of any newly replaced nuts and bolts after the first 8 hours of operation, then weekly.
 - Check all hardware is tight and secure.
 - Grease all driveline components.



In Dry Dusty conditions it may be necessary to grease PTO tubes every 8 hours.

- Grease all hitch components

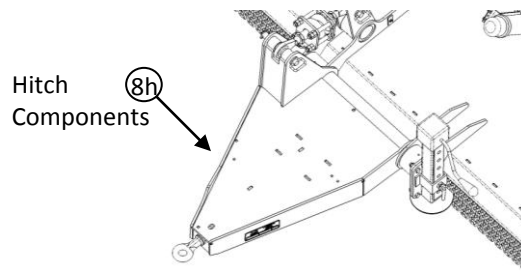

- Clean off deck and gearboxes of debris at the end of every day or if build up is excessive twice daily.



Caution: Build up of debris may cause gearboxes to overheat resulting in damage to the gearbox or in severe cases cause fire.

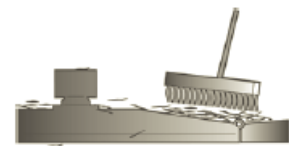

- Grease all Crank Arm bosses (when applicable)

25 Hours (Weekly)

- Check fluid level on all gearboxes is above fill line.

When Checking/Filling:

Use fluid level plug on gearboxes to check level. Ensure oil level does not go below fill line



All Gearboxes use Extreme Pressure 80W90 grade anti foaming gearbox oil.

- Check the condition of all pins for wear and replace if necessary.
- Some Gearboxes are also fitted with Housing level plug facilities. With Machine on firm level ground, remove plug – Oil capacity is correct when oil is level with bottom of plug hole. Replace level plug after inspection.

Maintenance & Service

50 Hours

- Replace the oil in gearboxes after the initial 50 hours of use. Then continue to replace oil annually.

The below table specifies the required amount of oil for each gearbox. Refer parts section of this manual to find the GPN of your gearbox.

GPN	OIL CAPACITY (LTRS)
226331	4.9
226332	1.9
223533	4
224197	4.4
226878	3.3
226839	1.8
226880	2.6
226879	2.4
226840	2.2
224421	4
223532	2.5
224196	6.5

 **Caution:** Allow gearbox oil to settle for up to 15 minutes before checking level on dipstick for an accurate reading.

DO NOT OPERATE MACHINE IF OIL LEVEL IS TOO HIGH, REMOVE EXCESS OIL TO CORRECT LEVEL

- Check hubs for bearing play and condition of seal.
- Check tyres for wear and if required rotate tyres.
- Check gearbox bolt, Re-Torque if necessary
- Re-Torque Driveline Yokes and overrun clutch bolts:
Yoke Bolts: 135.6 Nm
Over run Clutch: 135.6 Nm
- Drain Oil from gearbox and replace.

NB: Some Gearboxes may require the use of a suction device to drain due to restricted access. In most cases a drain plug can be found adjacent to the output shaft.

100 Hours

- Grease all axle hub bearings
- Check tyre pressures.

Recommended Tyre Pressure 60 PSI (415 KPa)

- Check skids for excessive wear.
- Pull apart sliding driveline PTO shafts, clean and apply grease to all sides.

Annually

- It is recommended hubs are dismantled, cleaned, inspected, and repacked every year. Whenever a worn or damaged seal is replaced it is recommended that the bearing assembly be cleaned and repacked with wheel bearing grease.
- Check all gearbox seals for leaks and damage. Replace as required.
- Replace oil in all gearboxes.
- Pull apart sliding driveline PTO shafts and apply grease to all sides.

 **Caution:** If the PTO sliding members are allowed to dry out to the point where the two halves can no longer slide freely, damage to the mower/slasher or tractor may result.

- Inspect all Hydraulic hoses for cracks, wear and leaks, Replace if required
- Inspect all cylinder seals for leaks and score marks. Replace if required
- Disassemble safety slip clutch and ensure all parts move freely and are not seized before re fitting to machine.

Maintenance & Service

Safety Slip Clutch

Gason mowers and slashers are equipped with safety slip clutches which protect the mower/slasher from damage due to overloading when impacting immovable objects, heavier cutting, etc.

The clutch consists of consumable clutch linings which should be checked before the machine is to be used for the new seasons work.

Replace linings if they have started to deteriorate, are fractured or are too thin to be serviceable. (50% of initial thickness)

Adjust clutch as per “Clutch Set-up” section in this manual

Clutch plates may absorb moisture and bond metal surfaces of clutch assembly. This may effectively seize up clutch, rendering the clutch ineffective in the event of blades hitting an immovable object.

 **Caution:** Prolonged use of clutch in a seized condition may result in: clutch hub wear, PTO shaft damage or gearbox damage.

Blades

General Maintenance

The Blades fitted are Gason Mowers & Slashers own performance mowing blades and are ‘stepped down & twisted’ for suction uplift of grass. The Blades are singular directional blades and are not reversible.

 **Danger:** Gason recommends Regular inspections of all blade bolts and nuts for excess wear to ensure premature failure of the rotor bar stack doesn’t occur. Failure to complete this could rest in death or serious injury.

Blade Replacement

Gason recommend the use of genuine Gason blades which can be purchased through or your local dealer. Gason recommends Blades are replaced in pairs on the same spinner bar to prevent imbalance of the

machine which could result in excess vibration.

As a guide blades should be replaced once they are worn to half of their original width on the outer tip.

Care must be taken when replacing blades to ensure the correct blades are placed on the correct side. Refer Blade Rotation section of this manual.

Blade Maintenance

Blades may be sharpened with a workshop grinder, but care must be taken to ensure blades are not heated excessively and excess material is not removed resulting in machine imbalance. Ensure when reinstalling blades that blades are placed back in the same positions on the machine as some blades are singular directional and are not reversible. Gason recommends this is carried out as a last resort option to allow operation while new blades are ordered.

NB: Blades must weigh within 7g (¼ oz) as matched pairs to ensure the machine is balanced.

NEVER WELD, HEAT BEND, HARD FACE OR MODIFY BLADES IN ANY WAY, EXCEPT TO SHARPEN.

Blade Hardware

- Check blade mounting hardware daily. Refer parts section of this manual for torque specification of various blade set-ups.
- It is recommended to change blade bolts, bushes and nyloc nuts every time blades are replaced.

Rotor Bars

Gason Recommends checking the rotors daily for foreign material which could become wrapped around the gearbox.

Problem materials encountered may be:

- Wire

Maintenance & Service

- Irrigation tubing
- Vineyard training wire
- Tough stringy grasses and weeds.

These materials if left unattended will cause damage to output seals or gearbox housings.

Immediately remove all foreign materials.

It is also strongly recommended that the operator regularly checks the rotor bars for damage such as twisting or chipping and when changing blades check for elongated blade bolt retaining holes.



Caution: When replacing a rotor bar, ensure support is placed under stack to prevent personal injury from falling parts.

Cleaning Machine

Machine body should be cleaned down immediately after use – this practice will help minimize deterioration of the deck surface.

The Mower/Slasher top deck features the “Fall Away” self clean deck, which, when the machine is in field use the operating vibration and motion will assist in the material falling off the deck.

The “Fall Away” top deck also allows for the machine to be washed down with water, which will immediately run off the body.

Do not concentrate wash down water in the area of the gearbox breather, seals or bearings. Water pressure may pass into the gearbox and contaminate the oil.

Note that a warm gearbox will draw in water as it cools down.

Torque Specifications



Caution: Torque values listed below should be used as a guide only. If a different torque value or tightening procedure is specified for a specific application, do not use these values.

- Refer to the “parts” section for proper grade and length of bolts for replacement parts

- Do not replace nyloc nuts with nuts and spring washers. Replace all parts with original, specified parts only.
- Values shown in the below table are for lightly oiled hardware.

Size	Thread Pitch	Recommended Assembly Torque					
		5		8		Wheel Stud	
S.A.E Grade Number		lbf.ft	Nm	lbf.ft	Nm	lbf.ft	Nm
Head Markings (Manufacturers marks may vary)							
7/16	UNF	43	59	60	82	-	-
7/16	UNC	39	53	54	74	-	-
1/2	UNF	67	91	94	128	-	-
1/2	UNC	59	81	83	113	-	-
5/8	UNF	135	184	186	253	-	-
5/8	UNC	117	159	165	224	-	-
3/4	UNF	235	319	325	441	-	-
3/4	UNC	210	285	290	394	-	-
7/8	UNF	370	502	520	706	-	-
7/8	UNC	335	455	470	638	-	-
1	UNF	550	746	775	1052	-	-
1	UNC	505	685	710	963	-	-

Metric Grade Number		8.8		10.9		Wheel Stud	
Head Markings (Manufacturers marks may vary)							
M10	1.5	29	40	41	56	-	-
M12	1.75	51	70	73	100	-	-
M16	-	-	-	-	-	170	231
M16	2.0	126	171	180	245	-	-
M18	1.5	-	-	-	-	254	345
M20	1.5	-	-	-	-	376	510
M20	2.5	247	335	351	477	-	-
M22	1.5	-	-	-	-	475	645
M24	-	-	-	-	-	500	679
M24	3.0	425	577	608	825	-	-

Maintenance Notes

Transporting

Road Travel

- Gason Mowers & Slashers recommends road travel at no more than 25kph for cropper toppers and 40kph for all other trailed machines.
- Slow down when travelling over rough roads.
- Raise Mower/Slasher to provide safe clearance from the ground, using tractor 3PL settings and /or rear trailing wheel assembly, machine will not lower further than stops allow, providing for safe road transport.
- Ensure tractor and Mower/Slasher is fitted with correct road travel signage and rotating beacons before commencing road travel (WHEN REQUIRED BY LEGISLATION) refer “General Safety’ Section of this manual.
- Be aware of roadside risks: do not allow machine to travel into roadside drains, culverts, the machine may become unstable and tip over.
- Be aware of roadside marker posts, if hit by tractor or Mower/Slasher they may become a dangerous projectile.
- Be aware of roadside clearances from parked vehicles, guard rails, bridge guides etc. connecting with an immovable object whilst traveling at road speeds up to 15kph will create a dangerous situation for the operator and other road users.
- Always ensure that an appropriate implement safety chain is attached from trailed Mower/Slasher drawbar to tractor.
- Slow down when travelling over rough roads, the drawbar spring adjuster (when fitted) will absorb most small, road generated shocks but will be of little use if large potholes or corrugations are encountered.
- Travel safely.

Machine storage

- Clean machine of settled debris, mud, dirt etc.
- Apply grease to all lubrication points.
- Check and top up gearbox oil level.
- Repair any damage or components in need of service attention.
- Place timber blocks under skids to keep machine clear of ground.
- Store machine under cover, if stored outdoors please cover with a sturdy waterproof cover.

Owner/Operator Acknowledgement

Gason Recommend all operators read this manual prior to operating the machine. It is recommended that the owner where they are not the operator ensure all operators of the machine fully understand its contents and ask that each operator sign below as an acknowledgement of having done so.

Owners name:
(please print)

Owners signature:

Date: .../.../.....

Operator Acknowledgement of manual contents (Where the owner is not the operator)

Operators Name	Operators Signature	Date
		.../.../.....
		.../.../.....
		.../.../.....
		.../.../.....
		.../.../.....
		.../.../.....
		.../.../.....
		.../.../.....
		.../.../.....
		.../.../.....

Troubleshooting

General Operation – Poor Cutting

This Section of the trouble shooting deals with some of the more frequently asked questions relating to the cut quality of the Gason mowers and slashers. Experience shows that the majority of cut quality issues are related to overlooked or neglected mower/slasher adjustments.

1. Is the Slasher/Mower operating at the correct PTO speed for your tractor?

Check the decal on the hitch or headstock of the mower/slasher

- 540 RPM
- 1000 RPM

2. Are the blades fitted correctly to suit the direction of cut?

Gason Uplift blades are single direction blades made to rotate in either clockwise or anti clockwise directions.

Failure to fit these in the correct position will result in a significant drop in cut quality

Refer maintenance & service section for correct fitment.

3. How Fast are you Cutting?

Try Slowing down. In tall, wet or dense conditions, ground speed must be reduced due to the volume of material in the cut chamber.

4. How high are you Cutting?

- For short, dry or sparse vegetation: The lower you cut, the more suction uplift there is and the closer you are to the stiff base of the plant stalk. (Avoid cutting too low in rocky conditions)
- For tall, lush or dense vegetation: Cut slightly higher or reduce ground speed to avoid overloading the chamber.

5. Are the blades badly worn or damaged?

Check or compare to a new blade and ensure replacement is in pairs.

Worn or damaged blades may cause excess vibration of the mower/slasher and reduce cut performance.

6. Are the clutches (torque limiters) slipping?

These clutches should be checked periodically to ensure they are set properly. The clutches will slip at a pre determined torque setting if they are properly maintained.

7. Is the cutter leaving one or two uncut sections visible the next day?

This is usually caused by excess ground speed over dense or lush vegetation. Cut debris is distributed on top of the uncut sections giving it a cut appearance. By the next day the uncut vegetation has stood back up.

- Reduce ground speed. Slowing allows more time for the material in the cut chamber and more blade passes in the process.
- Check the blades are not damaged or worn. Compare to a new blade and replace in pairs.

Troubleshooting

Operation

Symptom	Problem	Solution
Uneven Cut	Excessive Ground Speed.	Reduce Ground Speed.
	Incorrect Clutch set-up	Tighten Clutch
	Blades worn, dull or bent .	Replace Blades. (refer Maintenance & Service section)
	Improper Height Adjustment.	Adjust cutter height. (refer to Field Operation section)
	Turning too fast.	Reduce ground speed when turning.
	Conditions too wet.	Reduce ground speed or wait for condition to improve.

Uncut material	Excessive Ground Speed.	Reduce Ground Speed.
	RPM too Low.	Use full PTO speed . (refer tractor operators manual)
	Incorrect blade direction.	Install correct rotating blade. refer Maintenance & service section)
	Incorrect gearbox rotation.	Correct rotation of gearbox.

Poor Mulching	Excessive Ground Speed.	Reduce Ground Speed.
		Raise front of machine relative to the back to hold and circulate material longer. (refer Tractor Connection section)
	Cutting too high.	Set lower cutting height . (refer field operation section)
Conditions too wet.	Reduce ground speed or wait for conditions to improve.	

Windrowing or Uneven Material Distribution	Material Heavy & Lush.	Level the cutter deck . (refer Tractor Connection section)
		Increase ground speed .
	Incorrect gearbox rotation.	Correct rotation of gearbox.
Rear Deflectors set incorrectly.	Adjust rear deflectors. (where applicable)	

Cutter Vibration	Loose Blades.	Tighten blade bolts.
	One new and one old blade on same rotor bar stack.	Replace Blades in pairs.
	One Broken Blade.	Replace blades. (in pairs)
	Broken or defective U-joint cross bearing.	Repair or replace as necessary.
	Drive line bent or damaged.	Repair or replace as necessary.
	Bent or damaged PTO shaft.	Repair or replace as necessary.
	Bent or damaged Gearbox output shaft.	Repair or replace as necessary.
	Bent or damaged rotor bar.	Repair or replace as necessary.
	Worn CV Joint	Replace as necessary.

Troubleshooting

Blades

Symptom	Problem	Solution
Excessive Wear or breakage	Cutting too low in rough conditions. (eg. Sandy or Rocky)	Increase cutting height.
Bolt Loosening	Inadequate torque on blade bolts.	Tighten blade bolts to correct torque. (refer maintenance & servicer section)
	Lock nuts worn.	Replace nut.
	Cutting too low, scalping ground.	Increase cutting height.
Breakage	Cutting too low in rocky conditions.	Increase cutting height. Increase ground speed .
	Cutting with damaged or extremely worn blades.	Replace Blades. (in pairs)
	Blades Clashing during operation	Driveline failure, contact your dealer.

Gearboxes

Symptom	Problem	Solution
Shafts & Gears Break	Slip clutch seized causing drive line to experience high shock loads.	Inspect Clutch lining and repair/replace as necessary . (refer Maintenance & Service section)
Gearbox output shaft seal leaks	Operating with grass or wire wrapped on shaft in seal area.	Check seal areas regularly and clear any material.
	Worn Seal.	Replace seal.
	Bent or damaged output shaft and/or bearings.	Repair or replace as necessary.
Oil Seal Leaks	Worn Seal.	Replace Seal.
	Gearbox overfilled.	Check fluid level.
	Gearbox not vented.	Check that breather is clear and moved freely.

Gearboxes

Symptom	Problem	Solution
Skids Wearing Quickly	Machine set-up incorrectly and dragging skids along ground	Re adjust machine to allow clearance between skids and ground. (refer Tractor Connection section)

Troubleshooting

Driveline Clutches

Symptom	Problem	Solution
Overheated	Clutch Slipping.	Check for jamming blade or foreign object.
	Friction plates worn.	Replace plates & Adjust (refer to Maintenance & service manual)
	Excessive ground speed in heavy conditions.	Reduce ground speed.
	Excessive scalping.	Adjust cutting height. (refer Field Operation section)
	Clutch Slipping	Adjust Clutch as per Clutch Set-up section.

Seized	Prolonged storage in damp conditions.	Free up slip clutch. (refer Maintenance and Service section)
		Inspect clutch lining and repair/replace as necessary.
	Spring Bolts Over tightened	Loosen Bolts as per Clutch set-up section.

Drivelines

Symptom	Problem	Solution
PTO tube Fails	Shock Loads.	Avoid solid objects.
	Wing lift machine raised with rotors spinning	Ensure machine has come to a complete stop before raising.
PTO tube wears	Lack of lubrication.	Apply grease daily. (refer Maintenance & Service section)

Yoke or cross Fails	Lack of lubrication.	Apply grease daily. (refer Maintenance & Service section)
	Shock load.	Avoid solid objects.
	Slip clutch seized causing driveline to experience high shock loads.	Inspect clutch lining and repair/replace as necessary.
	Wing lift machine raised with rotors spinning	Ensure machine has come to a complete stop before raising.

Twisted	Slip clutch seized causing driveline to experience high shock loads.	Inspect clutch lining and repair/replace as necessary.
----------------	--	--

PTO Driveline Bent	Contact with drawbar.	Reposition drawbar. (refer Field Operation section)
	Driveline too long, bottoms out when operating through deep gullies.	Ensure PTO has been cut to suit tractor as per tractor connection section.
	Slip clutch seized causing driveline to experience high shock loads.	Inspect clutch lining and repair/replace as necessary.

Glossary

DRIVE-TRAIN – The complete power matched system from tractor to rotor.

POWER DIVIDER – Gearbox where power is transmitted through the input shaft from the tractor and out either side to satellite gearboxes.

CUTTERHEAD – Gearbox which has blades connected below to cut material.

TRANSFER ROTORHEAD – Gearbox that is a power divider and also drives down to a rotor head.

ROTOR BAR STACK – Arrangement of rotor bars and blades to form the cutting mechanism for the mower/slasher.

3PL – 3 Point linkage to tractor

2 POINT LINKAGE – Attached to tractor via the lower linkage arms, is semi-trailed via rear castor wheels.

SEMI TRAILED – As for two- point linkage.

HIGH TUB - High clearance under deck.

MULCH THROW SIDES – A short side allowing opening for cut mulch to be discharged.

DISCHARGE DEFLECTORS – A 45 degree plate that slides down on an angle to deflect mulch to under row.

FULL SIDE PLATE – Stops side discharge to allow rear discharge.

CANE MULCHER – Plate deflector on full side to direct prunings on to blades.

DOMED END ROLLERS –Domed ends fitted to roller casings allows rollers to slide over ground when turning with machine not raised, reduces fatigue on roller casing.

DUAL BLADE ANVIL KITS – Dual blade assemblies passing through trash anvils for finer mulching of prunings.

GPN – Gason Part Number

PTO - Power Take Off.