

BUSHRANGER™

Owners Manual

Bushranger BRC40 Chipper

V1 12/13



www.poweruplawncare.com.au

 **WARNING!** Read this manual before operating your Bushranger chipper.

Contents

Introduction	3
Warranty Instructions	3
Safety Precautions	3
Assembly Instructions	4
Operating the Chipper	5
Operation	5
Starting/ Stopping the machine:	6
Feeding Material into the Machine.	7
Unclogging the Cutter	7
Maintenance	8
Tensioning/ Replacing the Belt	8
Adjusting the Anvil	8
Replacing the Cutting Blade	9
Cleaning and Storage	9

Introduction

The Bushranger BRC40 Chipper is a precision built machine, designed for a high quality of finish and long service life. The way in which the machine is operated and maintained will have a profound effect on its performance and reliability.

This manual contains advice on the safe operation of your Bushranger BRC40 Chipper, which is offered for the guidance and protection of all those operating and servicing the machine. In the pursuit of continuous development and product improvement, Powerup Lawncare Products reserves the right to alter specifications without notice.

Warranty Instructions

Domestic: 2 Years from date of purchase.

Commercial: 3 months from date of purchase.

Hire & Rental: 3 months from date of purchase.

Safety Precautions

READ THIS MANUAL BEFORE USING THE CHIPPER, IT IS ESSENTIAL THAT OPERATORS STUDY IT FOR THEIR OWN SAFETY.

THE FOLLOWING PRECAUTIONS MUST BE TAKEN TO HELP PREVENT ACCIDENTS. A CAREFUL OPERATOR WHO USES COMMON SENSE IS THE SAFEST OPERATOR.

1. Read the instructions carefully. Be familiar with the controls and use of the equipment.
2. Never allow children or people unfamiliar with these instructions to use the machine.
3. Never operate the machine while people or animals are nearby.
4. The operator or user is responsible for accidents or hazards occurring to other people or property.
5. While using the machine, always wear substantial footwear and long trousers. Do not operate the Chipper when barefoot or wearing open sandals.
6. Check that the Chipper is in good working order before using.
 - Always visually inspect to see that the cutting blade, blade bolts and belt are not worn or damaged.
 - Regularly check that all nuts, bolts, linkages and connections are tight and secure.
 - Repair or replace excessively worn or damaged components with genuine Spare Parts only.
7. Always add fuel before you start using the machine.
 - Refuel and lubricate outdoors only. Never remove the fuel cap or attempt to add fuel while the engine is running.
 - Thoroughly clean any fuel spillages before starting the engine.
 - After refuelling or topping up with engine oil, ensure that the filler caps are replaced securely.
8. Store fuel in a cool place away from direct sunlight in a suitable container.
9. Do not operate the Chipper in a confined space where dangerous carbon monoxide fumes can collect.

10. Use the machine only in daylight hours or in good artificial light.
11. Always point the outlet nozzle in a safe direction.
12. Always wear suitable eye protection and ear muffs when operating the Chipper.
13. Only operate the Chipper when it is on a level surface.
14. Never attempt to move the Chipper while the engine and cutting disc are running.
15. Keep hands and feet well clear of rotating blades and components.
16. Always stop the engine when you leave the Chipper unattended.
17. Always stop the engine and disconnect the spark plug before attempting to clean the Chipper, un-block the cutting mechanisms, carry out maintenance or repairs, inspecting the Chipper after abnormal vibrations or after striking a foreign object.
18. Never operate the Chipper with defective guards, shields or without safety protection devices in place and in good working order.
19. Do not use this machine for anything other than its intended purpose. Do not modify the design of the machine in any way. If you have any doubts, contact your authorised service dealer.

HEALTH & SAFETY AT WORK:

This Chipper has been designed and constructed so that, in so far as reasonably practical, it will not endanger the safety and health of those working with it. This is however subject to the machine being properly used and maintained according to the conditions stated in this manual and elsewhere, which have been found necessary as a result of the research and testing of the Supplier.

Assembly Instructions

On receiving your Bushranger BRC40 Chipper, the Inlet Chute will need to be attached.

1. Remove the machine from its packaging.
2. Remove the bolts from the machine where the inlet chute will be attached.
3. Hang the Inlet Chute on the rear of the Chipper and attach using the two M10x25 nuts and bolts (provided). Tighten the bolts with two spanners.
4. Fill the engine with oil. Use high quality 10W30 oil. Refer to the supplied engine operation manual for the quantity of oil needed to fill the engine and other regular maintenance procedures relating to the engine.

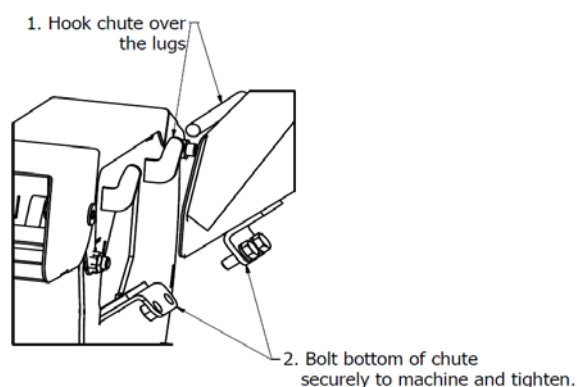

Operating the Chipper

SAFETY NOTICE

WARNING: PREVENT ACCIDENTS

Before operating the Chipper it is essential that:

The operator reads and understands this manual and has followed the safety precautions described. The maintenance check has been properly carried out and the Chipper is in good working order. The operator must use safety equipment, including gloves, eye protection, ear muffs and covered shoes. Failure to do so could result in damage and risk the health and safety of the operator.

Ensure the Chipper is on a flat, firm surface.

Ensure all nuts and bolts are properly tightened.

Ensure all safety guards are in place.

Make sure the inlet chute is free of debris before starting the unit.

Check the engine oil level.

Operation

Preventing accidental injury is the sole responsibility of each user of this machine. Ensure the operator of this machine is thoroughly familiar with the operation and safety procedures described in this manual.

Always make sure that the machine has been switched off, and the cutter is stationary, before the machine is moved to a different location, or opening the cutter housing.

Refuelling the Engine.

Before operating the Chipper, fuel needs to be added to the fuel tank.

During use, the engine should be left to cool before refuelling.

Starting/ Stopping the machine:

Cold Start

Ensure the ignition switch is set to the ON position.

Ensure the petrol tank is sufficiently full, turn the fuel tap to the ON position.

Slide the Choke lever to 'Full Choke' position.

Slide the Throttle lever across to the fastest setting.

Pull the start cord with sufficient force to start the engine.

Once the engine has started slide the Choke lever across to the off position.

Hot Start:

Follow the procedure for a cold start, but leave the choke lever in the 'off' position.

For more detailed instructions on the operation and maintenance of the engine, please refer to the supplied engine owners manual.

Stopping the Engine:

Turn the ignition switch to the 'off' position and wait for the cutter to stop rotating. Turn the fuel tap to the OFF position.

Feeding Material into the Machine.

Ensure that no contaminated material is fed into the Chipper. Metal, stones, sand and dirt will harm the cutting edge of the blades, leading to undesirable performance. Avoid feeding stringy materials such as cabbage trees into the Chipper as these can wrap around the cutter shaft bearing, damaging the seals.

Avoid feeding short pieces of wood into the Chipper. These short pieces tend to bounce off the cutting disc and act erratically. To chip these short pieces of material, combine their feeding with larger lengths of wood.

Freshly cut green material will be cut more efficiently than old wood which has dried over an extended period.

The maximum diameter of branches that the Chipper can process is 40mm, depending on the hardness of the wood. The Chipper has been designed to self-feed the material into the cutting blades. Because the Chipper has a large inlet chute, larger material has the tendency to stall the machine. To aid in stopping this, manually feed these larger branches down the chute, allowing the engine to maintain a high speed to effectively cut the material without stalling.

Ensure that the material is fed into the inlet chute wooded end first, leaving the leafy end to be pulled through. This aids in the self-feeding of the machine and helps the bushy material be effectively cut. Some of the smaller growth coming off the main branch may need to be trimmed so that it doesn't get jammed at the bottom of the inlet chute. As the operator becomes more familiar with the machine, they will be able to judge which branches need to be trimmed.

If material becomes clogged at the bottom end of the inlet chute, use a spare branch to push the blocked material down into the cutting blade. Ensure that the spare branch is of sufficient length so that the operator does not have to reach inside the chute.

The Chipper is able to process material other than just branches. Leaves, prunings and vines can be fed into the Chipper.

Unclogging the Cutter

If the Chipper stalls through overloading or clogging, stop the engine, ensure that the cutting disc has completely stopped and the ignition switch is in the OFF position and the spark plug disconnected. Open the cutter housing cover and remove all the material from the housing. Close the cutter housing, and restart the machine. Refer to the starting procedure at the beginning of this section for guidance. If any stringy material becomes wrapped around the rotor shaft, remove it before it works itself into the bearing.

Maintenance

Before carrying out maintenance or service work:

Stop the engine and wait for the cutting disc to stop rotating.

Allow the machine to cool

Find a dry, clean, level area.

Study and follow the published service procedures.

Do not work on a machine with loose clothing that could get caught in moving parts.

- Check for any loose nuts and bolts.
- Check the belt tension. The belts will stretch when they are new.
- Grease the cutter shaft bearings. Ensure not to overfill with grease as the seals could pop out of the housing.

For engine maintenance refer to the Engine service manual document.

Tensioning/ Replacing the Belt

Remove the belt cover and check the tension of the belt. To tension the belt, loosen and reposition the M12 locking nuts which set the engine height then refit the belt cover.

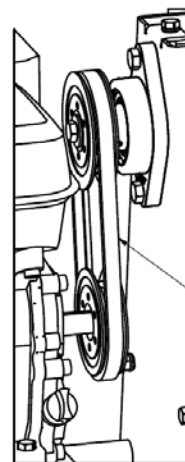

Ensure belt has no more than 10mm movement.

Adjusting the Anvil

Remove the inlet chute and loosen the two bolts holding the anvil. Set the distance from the edge of the anvil to the cutting blade to 2mm. Retighten the bolts and refit the chute.

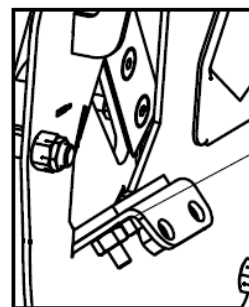

Loosen both nuts and bolts and reposition Anvil

Replacing the Cutting Blade

With the engine switched off, the cutting disc stationary and the spark plug disconnected, open the cutter housing door and remove the two cutting blades. The blades are double sided so in the first instance can be rotated and refitted. Take the blades to your authorised service dealer to resharpen the blades if both sides are worn.

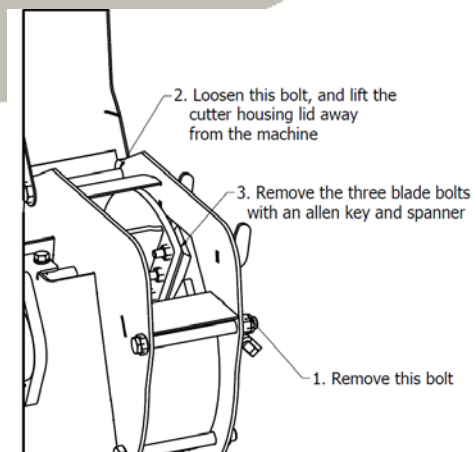

Cleaning and Storage

If you wish to clean the machine, wait for the engine to cool down and hose the machine down inside and out. Ensure that the drainage hole at the bottom of the cutter housing is not blocked.

Do not wash the chipper with high pressure water blasters.