

**POOLRITE**  
**ENDURO EN450 / EN650 Mk2 / EN850**  
**High Rate Sand Filtration Systems**  
**With V2000 Multifunction Valve**



# **Installation & Owners Manual**

# INTRODUCTION

Congratulations on choosing this Poolrite ENDURO High Rate Sand Filter system fitted with the exclusive Poolrite **V2000 Multifunction Valve**. This filter system incorporates the very latest technology in swimming pool water filtration.

The filter tank is moulded from a very advanced "*Engineering Polymer*" which enables Poolrite to apply a 5 year Warranty to the filter tank.

Poolrite's micro-slot underdrain system, featuring our exclusive folding lateral arm technology, combined with the use of a deep, dual-media sand bed, gives longer filter cycles and more efficient backwashing, resulting in less time being spent on maintaining your equipment and more time left to allow you to use and enjoy your pool.

**V2000 Multifunction Valve** is the latest in multi-function control valves and represents the culmination of several years of research and development at Poolrite to produce a filter control valve which provides far less noise and restriction to water flow, is easier to operate, requires no maintenance and is fitted with a user adjustable viewing direction for the pressure gauge.

The **V2000 Multifunction Valve** also has an inbuilt Sight Glass to give you a positive indication when backwashing is complete, thus eliminating guesswork and waste of pool water.

To ensure maximum performance, all systems should be fitted with a proven high performance Poolrite Pump featuring corrosion resistant design.

All equipment is weather resistant and constructed to protect your valuable investment.

Australian design and manufacture is your guarantee of after-sales backup.

# CONTENTS

<b>Introduction.....</b>	<b>1</b>
<b>How A High Rate Sand Filter Works .....</b>	<b>3</b>
<b>Delivery of Your High Rate Sand Filter .....</b>	<b>3</b>
<b>Attention Installer .....</b>	<b>4</b>
<b>Installation Instructions .....</b>	<b>5</b>
<b>Starting Up Procedure .....</b>	<b>7</b>
Priming The Pump	
Starting The Filter	
<b>Backwashing .....</b>	<b>8</b>
<b>Rinsing .....</b>	<b>8</b>
<b>Filter By-Pass / Waste .....</b>	<b>8</b>
<b>Recirculating .....</b>	<b>9</b>
<b>Valve Closed .....</b>	<b>9</b>
<b>Vacuum Cleaning .....</b>	<b>9</b>
<b>Operating The V2000 Multifunction</b>	
<b>Valve .....</b>	<b>10</b>
Adjusting Viewing Direction For The Pressure Gauge	
<b>Trouble Shooting .....</b>	<b>12</b>
<b>Specifications .....</b>	<b>13</b>
<b>Dimensions .....</b>	<b>14</b>
<b>Warranty Conditions .....</b>	<b>15</b>
<b>Warranty Card.....</b>	<b>17</b>

## HOW A HIGH RATE SAND FILTER WORKS

The filter pump draws water from the pool and forces it under pressure into the **V2000 Multifunction Valve** where it is directed into the top of the filter tank via an overdrain diffuser. The water then flows down through the sand bed, into the underdrain and back to the pool.

The action of the water containing suspended particles passing through the filter sand bed causes the larger particles to be trapped and retained by the grains of sand. Some of the very small particles may, however, pass completely through the filter and return to the pool, but in the process will have gained an electrostatic charge due to their high velocity over the sand grains. This charge causes these particles to be attracted together to form clusters which are then large enough to be trapped by the sand on their next pass through the filter.

This is a normal characteristic of all high rate sand filters.

As the quantity of suspended particles trapped in the sand bed increases, the passage of water becomes progressively restricted, but this also results in an improvement in filtration fineness. However when this restriction to flow becomes excessive (as indicated by the rise in gauge pressure) the filter must be cleaned to restore a normal flow of water.

Cleaning is achieved by reversing the flow of water so it flows upwards through the sand bed causing the individual grains of filter sand to become buoyant and allow the bed to expand and release the trapped dirt particles which are then flushed out of the filter to the waste drain. This process is called BACKWASHING

## DELIVERY OF YOUR SAND FILTER

Each Poolrite filter/pump is delivered in three cartons as follows:

### CARTON 1

- One factory assembled filter system ready for immediate installation.
- Installation & Owners Manual with Warranty Card.
- Quality Control Inspection & Packing list.

### CARTON 2

- One V2000 Multifunction Valve.
- Three 50 x 50mm take-off unions with 'O' Rings.
- Three 50 x 40mm reducing bushes.

### CARTON 3 (if ordered)

- One Poolrite pump.
- Two 50 x 40mm swivel couplings with backnuts and 'O' Rings.
- Installation & Owners Manual with Warranty Card.

# **ATTENTION INSTALLER**

- 1) BOTTOM OF INTERNAL STANDPIPE MUST BE LOCATED ON SPIGOT AT BOTTOM OF TANK BEFORE ADDING SAND!!**
- 2) THIS MANUAL MUST BE GIVEN TO THE POOL OWNER FOR COMPLETION OF WARRANTY DETAILS!!**

## **OPERATIONAL CHECK POINTS**

**Failure to adhere to the following directions will void the Warranty!**

1. Filter Pump should not be connected via extension leads as damage to motor can result.
2. At least 130mm clearance must be provided at fan cowl (rear) end of motor for efficient ventilation.
3. Should the filter system be housed in an enclosure, provision must be made for adequate ventilation.
4. Filter system must be installed in a position with effective drainage to guard against potential flooding in heavy rain or malfunctions in plumbing.
5. The pool water level must be at least half way up the skimmer box opening.
6. Make sure both skimmer box basket and pump basket are in place.
7. On initial vacuum cleaning of the pool, it is wise to use a filter sock in the pump strainer basket to prevent excess debris damaging the pump impeller seal.
8. Do not operate the filter system in FILTER mode unless the free chlorine level is between 0.5 and 3.0 ppm and the pH level is between 7.0 and 7.8 for concrete pools and 6.8 and 7.2 for other types of pools, or as recommended by the Pool Builder.
9. Do not vacuum clean the pool when the filter valve is in the BACKWASH position.
10. Do not operate the filter valve handle while the pump is running.

## **IMPORTANT**

**Read the following instructions carefully to ensure trouble free efficient operation of your filtration system for many years!**

# INSTALLATION INSTRUCTIONS

## IMPORTANT

- Tighten all backnuts by hand only — DO NOT USE TOOLS!
- Pump/Filter should be installed between 1.0 metre above or 1.0 metre below mean pool water level for correct operation.

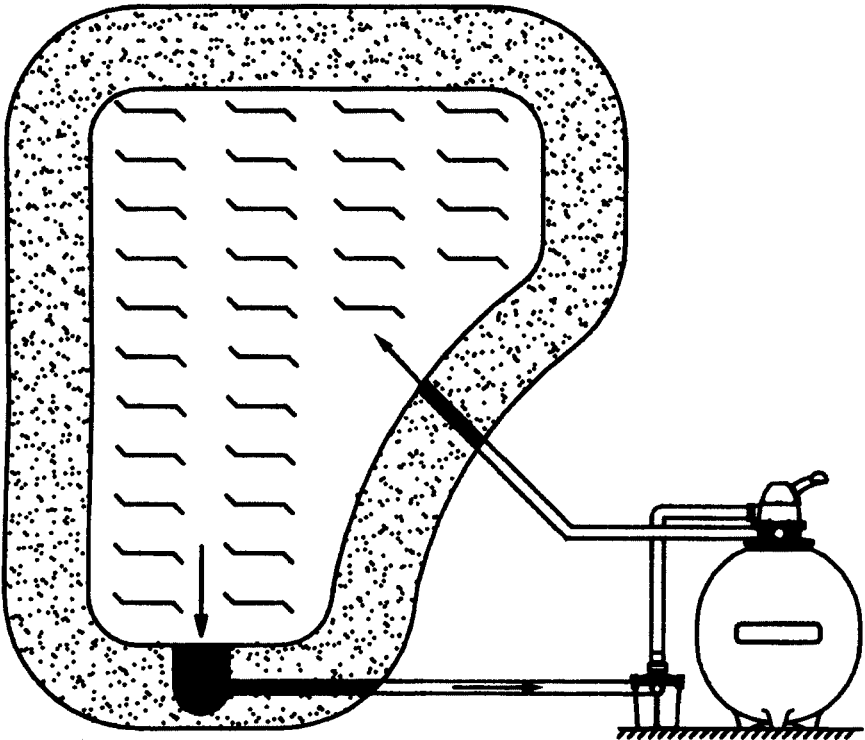

## Connecting The Pump To Filter

1. Place filter tank on a level concrete slab having minimum dimensions of 800mm x 610mm (32" x 24").
2. Position tank filter label to the front then place pump on the left side with suction port facing front. (For above-ground pools this may have to be rotated 180°).
3. Fit all of the moulded couplings to the *V2000 Multifunction Valve* ports and the pump ports.
4. Using standard PVC pressure pipe and fittings, fabricate suitable connecting plumbing between the top pump discharge port and the PUMP port on the *V2000 Multifunction Valve*.
5. Make all remaining connections from the pool and waste plumbing to the pump and *V2000 Valve*.
6. Remove *V2000 Multifunction Valve* after disconnecting PUMP, RETURN and WASTE plumbing and Split Clamp Band.
7. To ensure correct separation from internal standpipe assembly:
  - a) Lift the *V2000 Multifunction Valve* approximately 250mm.
  - b) With other hand, reach under valve then twist and pull standpipe downwards until separated.
8. Place valve and rubber gasket in a clean place.
9. Re-position bottom of standpipe assembly in bottom of tank.
10. While holding standpipe central in the neck of the tank, gently push outer ends of all lateral arms down until they contact the tank wall.
11. Fit white moulded standpipe locator between top of standpipe and tank neck. Fit red plastic cap to top of standpipe (this will prevent sand entering standpipe during charging).
12. Quarter fill tank with water.
13. For EN650 Mk2 & EN850 only: Add the correct amount of graded pea gravel (refer specifications) and distribute evenly across the bottom of the tank. This should completely cover all parts of the underdrain assembly.
14. Add the correct amount of graded filter sand (refer to specification), levelling the bed when needed.
15. Remove white moulded standpipe locator, then clean all sand and dust from neck area of tank.
16. Replace, rubber gasket and *V2000 Multifunction Valve*.
17. Refit and tighten Split Clamp Band.
18. Re-connect PUMP, RETURN and WASTE plumbing to *V2000 Multifunction Valve*.

## STARTING UP PROCEDURE

### Priming The Pump

Priming the pump is required if the installation is above the pool water level. If the pump is installed below the water level isolating valves should be fitted then go to "Starting The Filter".

1. Remove clear pump lid, then fill pump bowl with water to the suction inlet level.
2. Check the rubber pump lid seal is clean and lightly lubricated with silicone-based grease and is correctly located in the groove.
3. Replace clear lid.

### Starting The Filter (New Pools)

1. Set **V2000 Multifunction Valve** to WASTE position.
2. Vacuum clean pool to waste to remove excess debris from pool and pipes (refer to **VACUUM CLEANING** section page 9).

### (Existing Pools)

3. Set **V2000 Multifunction Valve** to BACKWASH position.
4. Ensure all plumbing lines to and from the pool are clear (i.e. shut off valves are OPEN).
5. Switch the pump ON.
6. Observe reaction through clear pump lid.

The pump will first draw water in surges until all the air within the pump bowl and suction piping has been expelled. If air is still present after approximately 3 minutes repeat "Priming The Pump" instructions, then if air is still present, check the following:

- a) Pump lid correctly tightened onto seal.
  - b) "O" Rings fitted under unions.
  - c) Backnuts tightened fully (by hand only).
  - d) Plumbing joints (all glued)
  - e) Sufficient water in pool.
  - f) Skimmer weir is free and not jammed.
  - g) Strainer baskets not blocked.
  - h) All appropriate in-line valves open.
- i) If air is still present the suction pipe to the skimmer should be checked.

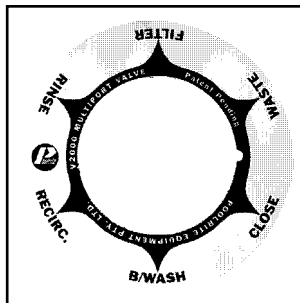

7. After pump has fully primed, run for approximately three (3) minutes or until water in V2000 Sight Glass becomes clear.
8. Switch pump OFF.
9. Turn valve handle to RINSE position.
10. Switch pump ON and run until water in Sight Glass is again clear (approx. 20 seconds).



11. Switch pump OFF.
12. Turn valve handle to FILTER position.
13. Switch pump ON.
14. The filter system is now filtering the pool and the pressure gauge should be reading in the green FILTER range.
15. When the pressure gauge reading reaches the start of the red CLEAN band, the filter must be cleaned by BACKWASHING.

## **BACKWASHING**

1. Switch pump OFF
2. Remove vacuum cleaner plate (if fitted) from skimmer.
3. Turn *V2000 Valve* handle to BACKWASH position.
4. Switch pump ON and run until water in *V2000 Valve* sight glass is completely clear.
5. Switch pump OFF.
6. Turn *V2000 Valve* handle to RINSE position.
7. Switch pump ON and run until water in *V2000 Multifunction Valve* sight glass is completely clear (about 20 seconds).
8. Switch pump OFF.
9. Turn *V2000 Valve* handle to FILTER position.
10. Switch pump ON.
11. Reconnect automatic vacuum cleaner (if fitted) to skimmer.

The system is now filtering normally again and the pressure gauge should be reading in the lower portion of the green FILTER band.

**IMPORTANT:** Before and after backwashing, check that the pool water level is correct.

## **FILTER BY-PASS / WASTE**

If the pool is often overfilled by rain and to return it to its normal level, proceed as follows:

1. Switch pump OFF.
2. Set *V2000 Multifunction Valve* to WASTE position.
3. Switch pump ON. The excess water is discharged to waste.
4. When correct water level has been restored, switch pump OFF.
5. Set *V2000 Multifunction Valve* to FILTER position.
6. Switch pump ON. The filter is now operating normally.

**A USEFUL HINT:** When lowering the pool level with the *V2000 Valve* set in the WASTE position (only), vacuum cleaning may be performed at the same time, as under this condition the filter will not collect sludge and debris as it will all be discharged to WASTE.

## RECIRCULATING

With *V2000 Multifunction Valve* set in RECIRCULATE position the pool or spa water is recirculated via the pump without passing through the filter. This can be useful to provide extra flow for boosting spa jets or added circulation for heating.

## VALVE CLOSED

The pump must always be switched OFF when *V2000 Multifunction Valve* is in the CLOSED position. This setting is used to prevent the filter contents draining back through the pump when the lid is removed to enable cleaning of the strainer basket. Ensure *V2000 Multifunction Valve* is in the FILTER position before restarting the pump.

## VACUUM CLEANING

1. Switch pump OFF.
2. Set *V2000 Multifunction Valve* handle to FILTER position.
3. Position vacuum plate in skimmer box after first checking main drain connection port is closed.
4. Expel air from vacuum hose. This can be done simply by:
  - Connect the vacuum hose to vacuum head, attach accessory handle and submerge it in the pool.
  - Switch pump ON then place other end of hose on return to pool inlet thus filling hose with water and at the same time expelling air.
5. Switch pump OFF.

6. Connect free end of hose into skimmer box vacuum plate.
7. Switch pump ON and proceed to vacuum clean pool.
8. Check pressure gauge during vacuum cleaning and backwash filter if necessary.
9. After vacuum cleaning is completed it is recommended that the *V2000 Valve* handle be positioned BETWEEN any two of the marked positions and the pump switched on for about 10 seconds to expel excess air from the filter.
10. The pump should then be switched OFF, the *V2000 Valve* handle moved to the RINSE position and the pump switched ON again for another 10 to 20 seconds until the water in the sight glass becomes clear.
11. Switching the pump OFF and setting the *V2000 Multifunction Valve* handle to the FILTER position will set the system back ready to filter the pool water again.

POOLRITE *V2000 Multifunction Valve*



## IMPORTANT

- \* Under no circumstances must the vacuum cleaning operation be performed with the *V2000 Multifunction Valve* set in BACKWASH or RECIRCULATE positions.
- \* The *V2000 Multifunction Valve* handle must never be operated when the filter pump is running.

## OPERATING THE V2000 MULTIFUNCTION VALVE

### ADJUSTING A VIEWING DIRECTION FOR THE PRESSURE GAUGE

**NOTE:** Before proceeding it should be noted that the viewing direction for the pressure gauge with the valve set in the normal FILTER position can be changed at this stage by simply rotating the whole gauge. It is not necessary to loosen any screws or be concerned about water leaks as the valve and pressure gauge have been specially designed to incorporate this unique feature.

If the current viewing direction is unsuitable it can be changed as follows:

1. Turn the pump OFF.
2. Carefully pull the lugs at the bottom corners of the black Rubber Flap (beneath the handle) out of the holes on either side in the Clear Cover (see diagram above).
3. Place your thumbs each side of the viewing recess in the Clear Cover. While pressing forward with your thumbs carefully pull apart and lift the opposite edges of the

Clear Cover slightly to disengage the lugs in the locating groove.

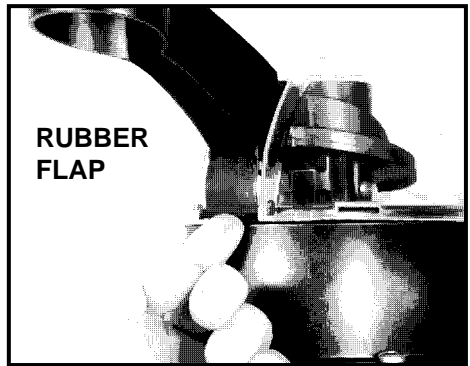

4. The Clear Cover can then be slid back slightly then lifted straight up to allow access to the pressure gauge.



5. While holding the outside body the pressure gauge can be rotated to the desired position (see diagram below).

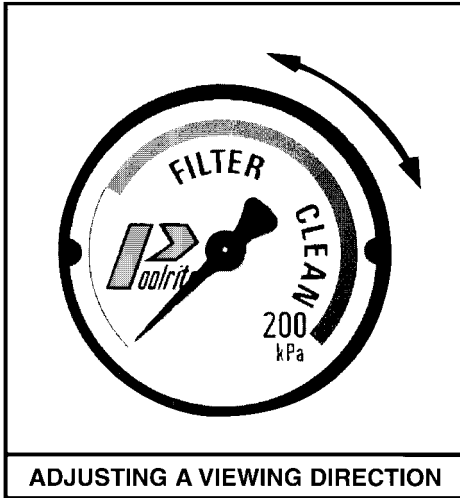

8. Refit the lugs on the ends of the Black Rubber Flap into the holes in the Clear Cover making sure that the little tabs are pulled fully through (the use of a small pair of pliers or tweezers can be helpful for this) so as to prevent the Flap from coming out when the handle is pressed.

6. Refit the Clear Cover over the handle and engage the small lug beneath the viewing recess.
7. Gently push down on the opposite side of the Clear Cover until the lugs either side of the slot snap into place.

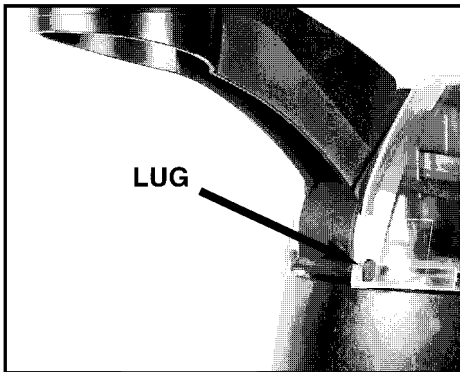

# TROUBLE SHOOTING

---

Filter Pressure Builds Up Rapidly

- Check eyeballs in pool are open.
- Check for algae in pool.
- Vacuum cleaning has been done with valve in backwash position.
- Ineffective backwashing due to poor water flow. Check for restrictions from blocked strainer baskets or air leaks in pump or suction plumbing. Check that automatic pool cleaner has not been left connected to skimmer during backwashing.
- Check for algae inside filter.

---

Air Bubbles Back to Pool

- Check sufficient water flow.
- Check suction pipe connectors are tight.
- Check pump lid seal is clean, lubricated with silicone grease and correctly fitted and tightened.

---

Water Drains Back to Pool When Pump Switched Off

- Check pump lid for leaks.
- Check *V2000 Multifunction Valve* for leaks.
- Check backnuts are tight on all pipe connectors.

---

Pump Loses Suction Power

- Check strainer baskets in pump and skimmer box are not blocked with debris.  
NOTE: After opening the pump strainer pot lid air will have entered the filtration system. Re-priming the pump may be necessary when the system is started again.
- Check filter condition from pressure gauge and backwash if necessary.

## TROUBLE SHOOTING

Algae/Milky Coloured Water

- Contact your pool builder or local pool shop for advice on chemical balancing the water, as damage to the filtration equipment or pool surface may result if not corrected.

<b>SPECIFICATIONS</b>		<b>EN850</b>	<b>EN650 Mk2</b>	<b>EN450</b>
<b>SUITABLE POOLRITE PUMP MODELS</b>		EP930 EP1100	EP750 EP930	EP550
Max. Flow Rate	(L/min)	445	320	170
Sand Grade	(mm)	-1.2 +0.6	-1.2 +0.6	-1.2 +0.6
Sand Weight	(kg)	180	100	60
Gravel Grade	(mm)	-3.18	-3.18	n/a
Gravel Weight	(kg)	60	40	n/a

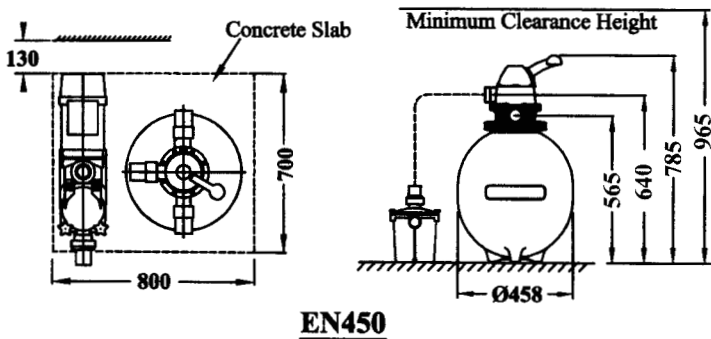
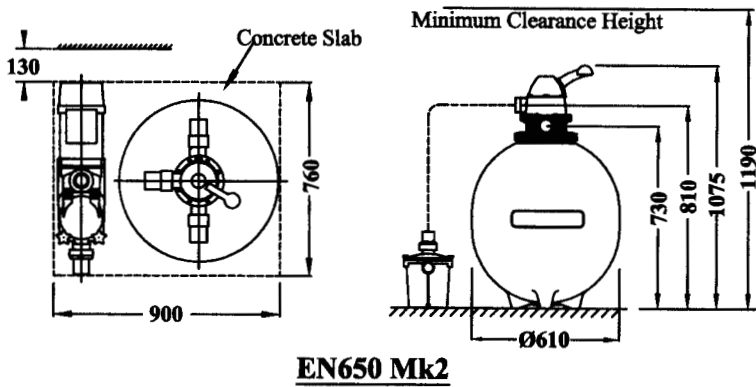
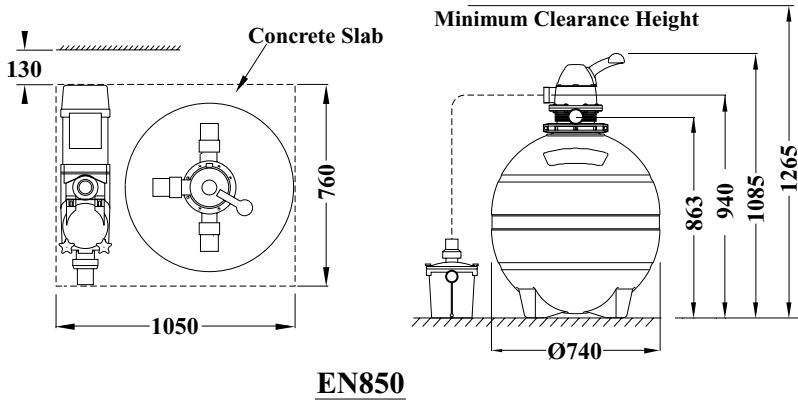

# WARRANTY CONDITIONS

**Poolrite Equipment Pty. Ltd.**

**A.B.N. 11 001 674 004**

## **POOLRITE SAND FILTRATION SYSTEMS**

Your POOLRITE Filtration Equipment is manufactured to the highest possible standards and most up-to-date technology. Accordingly the equipment carries the following Warranty, should a fault occur due to faulty manufacture or materials.

### **Important:**

In the event of a fault covered by Warranty occurring, the Purchaser must, in the first instance, contact Poolrite Equipment Pty. Ltd. or the nearest authorised Poolrite Distributor.

### **ENDURO EN450 / EN650 Mk2 / EN850**

1. All components in the Filtration System, with the exception of the Filter Tank, carry a one year (12 months) Warranty from the Date of Purchase by the Original Owner.
2. Due to Poolrite's Advanced Moulding Technology, the Filter Tank (the most important part of your Filtration System) carries a special Extended Warranty of five years from the Date of Purchase by the Original Owner. The terms of this Warranty cover full replacement, excluding the cost of labour, of a defective Filter Tank for the Original Owner for a period of 5 years.
3. No claim in pursuance of this Warranty will be recognised unless received by Poolrite during Warranty period.
4. The "Filter Tank" is defined as the Filter Housing Moulding only, without any attachments such as Valves, Internal Fittings or Plumbing, etc.
5. The Warranty is void if the following are not adhered to:
  - The equipment must be installed and used in accordance with the instructions supplied.
  - The Pump fitted to the Filter Tank must be sized in accordance with the Poolrite Specifications.
  - The Equipment is designed to be used with swimming pool or spa pool water, chemically balanced in accordance with the Langelier Saturation Index with a pH of 6.8 to 8.0 that is regularly treated with a sanitising system utilising chlorine either added in compound form or generated in situ in concentrations as recommended by the relative State Health Departments. Should other chemical treatment systems or parameters be used, Poolrite will not be responsible for damage done by corrosion, scaling and stress cracking of the equipment or the shortened filter cycles resulting therefrom.
  - If, in the opinion of Poolrite, the equipment has been subjected to other than normal swimming pool or spa pool use or has been improperly serviced or maintained.
6. This Warranty is applicable to workmanship and materials only. Poolrite will replace, at no charge; all parts returned freight paid, which display faulty workmanship or materials. Poolrite Equipment Pty. Ltd. accepts no responsibility for loss, damage or injury to person or property arising from Warranty failure of equipment, or installation of that equipment, unless with the express authority of Poolrite or its Authorised Distributors and this Warranty shall not extend to any expenditure otherwise incurred.



# Warranty Card



# Warranty Card



\_\_\_\_\_  
Name of Purchaser

\_\_\_\_\_  
Address

\_\_\_\_\_  
Purchased From

\_\_\_\_\_  
Date

\_\_\_\_\_  
Equipment and Model



***IMPORTANT:*** *This Warranty Card should be filled in and returned to Poolrite Equipment Pty. Limited.*

**Queensland Head Office  
Sales & Export Brisbane**  
415 Creek Road,  
P.O. Box 520,  
Mt. Gravatt. QLD 4122  
Telephone: (07) 3323 6555  
Facsimile: (07) 3323 6500

**Poolrite Equipment Pty. Ltd.**  
Unit 22, 761 Great South Road,  
Penrose. Auckland  
New Zealand.  
Telephone: (09) 571 0210  
Facsimile: 0800 766 574





**Poolrite Equipment Pty. Ltd.**  
415 Creek Road,  
P.O. Box 520,  
**Mt. Gravatt. QLD. 4122 Australia**  
Telephone: (07) 3323 6555  
Facsimile: (07) 3323 6500

**Poolrite Equipment Pty. Ltd.**  
15 Yiannis Court,  
**Springvale. VIC. 3171 Australia**  
Telephone: (03) 9547 4188  
Facsimile: (03) 9547 1023

**Poolrite Equipment Pty. Ltd.**  
36 Hugh Ryan Street,  
**Garbutt. QLD. 4814 Australia**  
Telephone (07) 4779 4880  
Facsimile (07) 4779 6714

**Poolrite Equipment Pty. Ltd.**  
6 Forsyth Close,  
P.O. Box 7055,  
**Wetherill Park. N.S.W. 2164 Australia**  
Telephone: (02) 9729 0166  
Facsimile: (02) 9729 2759

**Poolrite Equipment Pty. Ltd.**  
Unit 10/16 Ledgar Road,  
**Balcatta. W.A. 6021 Australia**  
Telephone: (08) 9344 3871  
Facsimile: (08) 9345 3923

**Poolrite Equipment Pty. Ltd.**  
Unit 22, 761 Great South Road,  
**Penrose. Auckland**  
New Zealand.  
Telephone: (09) 571 0210  
Facsimile: 0800 766 574