



Owners Manual



HOMESTEAD DOME TENT

www.oztrail.com.au

DTS-HOM-B

IMPORTANT SAFETY AND CARE INFORMATION

PLEASE READ BEFORE SETTING UP YOUR TENT/SHELTER

At the time of purchase we guarantee that this product is supplied without fault in construction, materials or function. We recommend that you assemble it as a trial before going away. If problems are discovered in the brand new product, they will be dealt with under our warranty.

- This product is designed as a portable and temporary structure; it is not designed to be a permanent structure or dwelling.
- Intermittent use only. Although our polyester fabrics are treated for extra UV resistance, continuous exposure to sun light will break the fabric down. Fading of colour is an early warning sign. These tents/shelters are not designed as permanent dwellings or structures.
- Do not leave this product unattended if bad weather is expected. If assembly instructions are followed correctly, this product will withstand mild winds and rain. In gusty winds and storms you must collapse the tent/shelter.
- We recommend that you discuss adding this investment to your household Insurance Policy with your Insurance Agent.

CAMP SAFE - SAFETY HABITS

The fabric may burn if left in continuous contact with a flame from any source. Also, the application of any foreign substance to the tent fabric may render the flame resistant properties ineffective.

To prevent injury caused by gas poisoning or suffocation -

- Do not use fuel burning, oxygen consuming devices inside the tent. This includes candles, gas lanterns, kerosene lamps, stoves, cooking and heating appliances
- Do not use gas appliances of any kind inside the tent/shelter

EXTREME CAUTION - Gas or fumes or lack of oxygen within the tent/shelter could result in unconsciousness, brain damage and even death

To prevent injury caused by fire -



- Do not pitch the tent/shelter near a camp fire or any other flame source
- Do not use candles, matches or any other flame source in or near the tent (this includes stoves, cooking equipment, lighting and heating appliances)
- Only use recommended water repellent compounds on the tent/shelter fly
- Do not spray tent fabrics with insecticides



To prevent injury caused by electricity -

- Always exercise care when using electricity and electric lighting in and near tents/shelters. Only use 12 volt lighting.

To prevent injury caused by your camping environment -



- Do not pitch your tent/shelter on an area that could get flooded



- Do not leave your tent/shelter erected in strong winds - collapse the tent onto the ground and seek refuge in your vehicle



- Do not pitch your tent/shelter near cliffs in case of collapse or rock fall



- Do not pitch your tent/shelter under trees with dead branches or under trees known to drop branches

Product Code ~ DTS-HOM-B

PRODUCT AND PARTS

Thank you for purchasing a superior OZtrail product. Please keep this Owners Manual in a safe and dry place, it contains important and helpful information.

IMPORTANT

We recommend that you set up this product before you leave for your trip. Check that all parts are present and that you familiarise yourself with the assembly and disassembly of the product. If you have any problems, your OZtrail dealer will be able to sort it out for you.

You should have the following parts: -

Product Code ~ DTS-HOM-B

Part Description

- 2 x Long fibreglass poles
- 2 x Medium fibreglass poles
- 5 x Short Portico arch (roof) poles
- 10 x Steel Portico poles
- 10 x 2-way hubs attached to the tent
- 1 x Ventura RoofVent fibreglass Pole
- 2 x Steel Awning Poles

- 1 x Pole Bag
- 1 x Gear Loft
- 17 x Guy Ropes
- 43 x Pegs
- 2 x Cup Holders
- 1 x Peg Bag
- 1 x Tent Inner
- 1 x Fly Cover

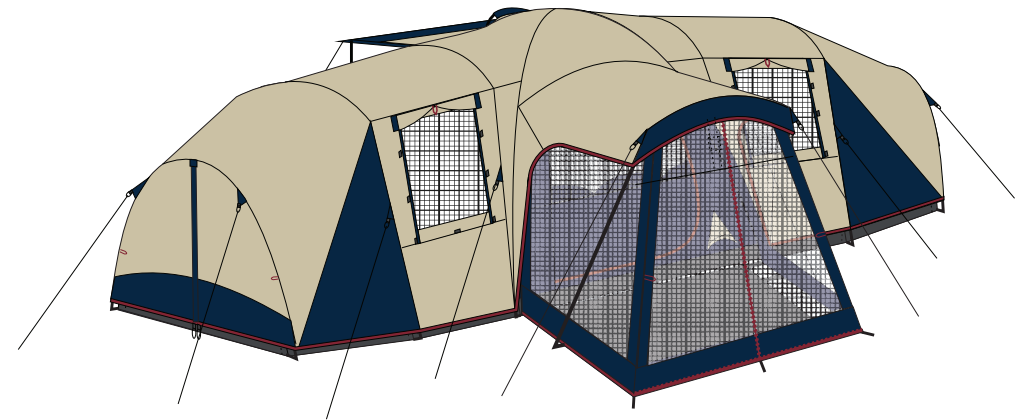

PLEASE NOTE - Due to our policy of continual product development, specifications and features of the product may vary from details within this Owners Manual.

ASSEMBLY INSTRUCTIONS

Step 1 - Select the site

It must be:-

~ level, sheltered, free of roots, sticks and rocks and well drained.

Remove the contents from the storage bag.

Step 2 - Laying out the tent

Position it so the doors face the desired direction. There are 21 initial peg down points. Start with the front side 11 first. Peg them down through the Ring of the Ring & Pin fittings pulling the floor firmly as you work from one end to the other. Then peg out the back side 8 also pulling firmly against the adjacent peg and the peg beside it as you work down the tent. You will get a chance to check out that the floor is pegged out square and plumb after you install the poles see figure 1 .

This Oztrail Sportiva Tent is Tent Power System compatible. You can install, the leads and slot the end fitting through the Port in the roof of the inner tent before the next step.

Step 3 - Assemble the poles

2 x Long crossover fibreglass poles for Central Room

2 x Medium length small diameter fibreglass poles for the Bay Windows

5 x Short Portico arch (roof) poles. 4 over the Bedrooms and 1 for the Screen Room

10 x Steel Portico poles, 8 for the tent body and 2 for the screen room.

10 x 2-way hubs attached to the tent

1 x Ventura Roof Vent Pole (fibreglass)

2 x Steel Awning Poles (they have the spigot points)

Do not stand, sit on or drive over the poles!

Step 4 - The Central Room

The 2 long crossover poles run from either side of where the Screen Room meets the main body of the tent, over the top and down the other side. Feed these through the pole sleeve and fit the ends into the back Pin of the Ring & Pin fitting and then the front. Attach the C-Clips to the poles. See figure 2

IMPORTANT

After unpacking the tent, use the check list on page 4 to make sure you have all the parts.

ASSEMBLY INSTRUCTIONS

Step 5 - Fitting the Portico Poles

Taking note of the colour of the Portico Arch poles and the binding colour on the pole sleeve see figure 4, insert the 4 fibreglass poles through the pole sleeves over the Bedrooms and the sleeve over the entrance of the Screen Room. Fit the ends into the 2-way hubs that are pre-attached to the tent. Then insert the steel leg poles into the hub and fit the Pin of the Ring and Pin fitting into the poles at ground level. Clip all C-Clips to the steel poles.

N.B. If any of the ferrule edges of the fibreglass poles get caught on the pole sleeve, do not force the pole through, take care and unhook the ferrule edge.

Step 6 - Installing the Side Poles

The 6 longest - 2 for the front screen room and 4 over the entry of the bedroom and the 4 shorter are for over the bedrooms

Step 7 - Fitting the Bay Window Pole

The remaining long fibreglass poles are for the bay windows. Insert them into the sleeves & Ring & Pin fittings.

Step 8

Now hook all C-Clips to all the leg poles to finally attach the tent inner to the poles.

Step 9 - Installing the Ventura Roof Vent Pole

Unfold the fly and locate the Ventura Roof Vent. The sleeve is external and the pole is fitted externally. Simply slide the pole through the sleeve and slot the pole-ends into the webbing end sockets. See figure 3

Step 10 - Attaching the Tent Fly

Lie it over the tent. You will find the PosiBrace attachments on the inside of the guy line points on the fly. Wrap the Touch Tape around the poles and do up. This secures the fly to the pole structure. Then clip the J-Hooks located on each attachment point around the bottom perimeter of the fly to the Rings of the Ring & Pin fittings. Peg out all remaining peg points and ensure all guy lines are pegged out.

FIGURES AND ILLUSTRATIONS

Figure 1

Peg Points indicated by arrows

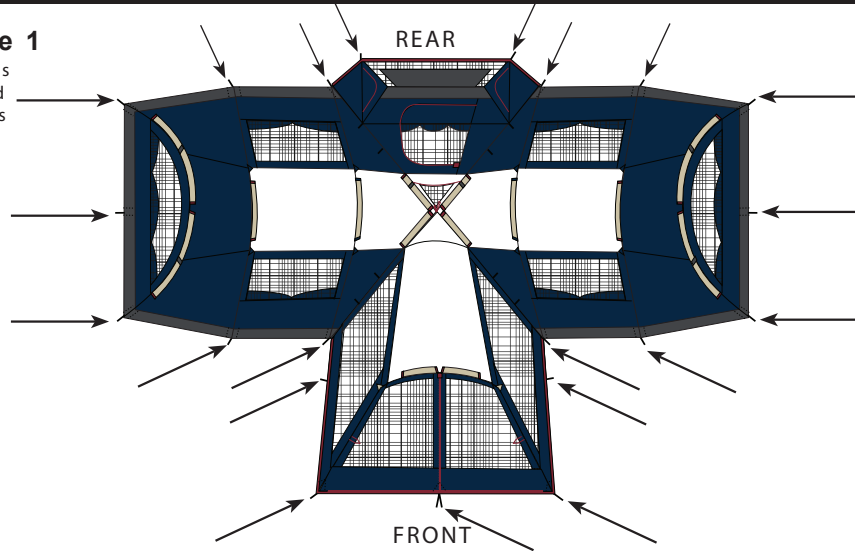
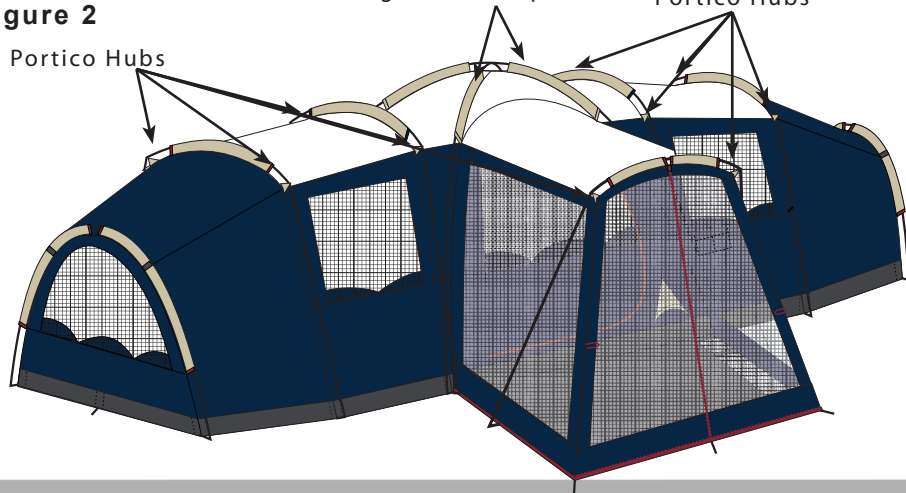

Figure 2

Portico Hubs

Long Crossover poles

Portico Hubs



FIGURES AND ILLUSTRATIONS

Figure 3



Figure 4

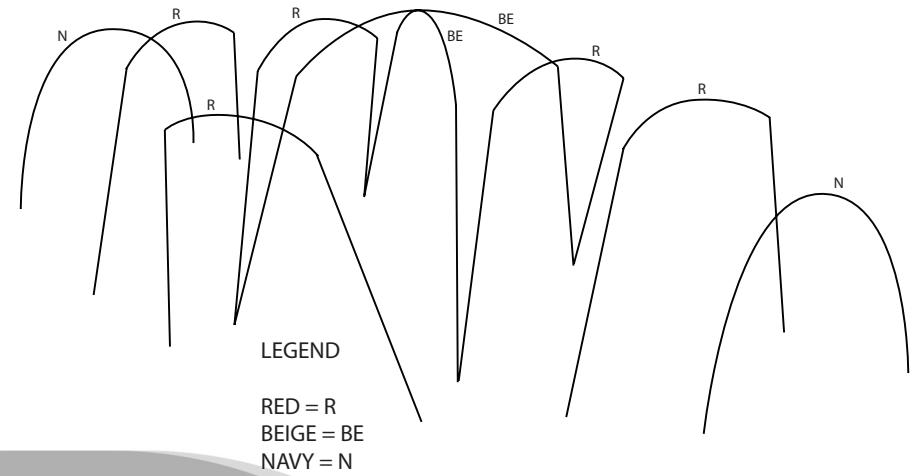

DISASSEMBLY INSTRUCTIONS

- Step ①** Release guy ropes. Release velcro that attaches the fly to the poles. Remove Portico poles. Remove fly from tent. Lay fly flat on ground and fold the fly in half, third or quarters. (folding depends on the length of the pole carry bag.)
- Step ②** Unzip doors and windows, collapse the tent by removing and disassembling the poles. Place the poles in the pole carry bag and tie shut.
- Step ③** Remove pegs. Do not remove pegs from the ground by pulling on peg loops. This may cause the peg loops to tear out of the seam.
- Step ④** Spread the tent out flat with all loose fabric within the edges of the tent base. Try to flatten the tent as much as possible.
- Step ⑤** Fold the tent in half, third or quarters. (folding depends on the length of the tent pole sections.) Place the folded fly in tent as you make the last fold.
- Step ⑥** Place the pole bag on back end of tent (trapped air is more easily forced out of the open door when you are rolling up the tent.) The folded tent should be the width of the pole bag.
- Step ⑦** Beginning at the back end, roll your tent tightly around the pole bag, forcing out excess air as you roll. Keep tent edges straight and pole bag centred as you roll.
- Step ⑧** When tent is rolled up, tie straps around it and place into tent carry bag with peg bag, instruction sheet, and other miscellaneous parts. If tent won't fit into bag, unroll and reroll more tightly.

**Do not remove pegs from the ground by pulling on peg loops.
This may cause the peg loops to tear out of the seam.**

FOLDING INSTRUCTIONS

Important

Do not store your tent away wet, damp or dirty. If you have no choice but to return home from your camping trip with a wet, damp or dirty tent, make sure you lay it out to air in a cool, dry and shaded place and only pack it away when it is completely dry and clean.

Figure 5

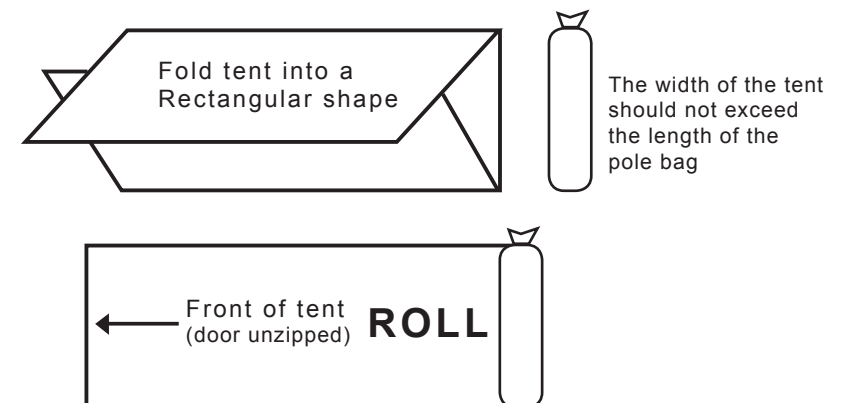



PROLONGING THE LIFE OF YOUR TENT/SHELTER

- **Intermittent use only. Although our polyester fabrics are treated for extra UV resistance, continuous exposure to sun light will break the fabric down. Fading of colour is an early warning sign. These tents/shelters are not designed as permanent dwellings or structures.**
- During rain always lower awnings to avoid water ponding and collapsing the awning.
- If seam seal tape is lifting, simply cut the lifted tape off and apply seam sealer to the seam.
- Never store a wet and/or soiled tent/shelter; as mildew and corrosion can form within a few days. This condition is not covered by the warranty. Always allow the tent to dry completely before packing and stowing. If mildew occurs, use a soft bristle brush or sponge with mild detergent to clean it off.
- The elastic shock cord within the poles is provided for easy assembly of the poles. The shock cord is not required for any structural reason. The poles and tent perform perfectly well without the shock cord. Age, over stretching and mishandling may cause failure. Shock cord is not covered by warranty. It's easy to replace, see instructions.
- Sometimes the zipper coil bursts open or does not close. This could be due to wear or metal fatigue. The problem can be easily fixed, see instructions.
- First aid for tears and ash burns is to carry a roll of tape, industrial or medical. This not only blocks the hole, it will prevent further tearing. It could have other uses around the camp site too.
- When removing pegs, do not use the webbing or corner of the tent as your handle. Either use another peg, a peg remover or the claw of a hammer hooked under the peg to remove them.

IMPORTANT - CONDITIONING YOUR NEW CANVAS TENT

Once you get your new tent home, it is important to condition the tent. Simply pitch your tent and wet it down with your garden hose. Pay particular attention to the seams - the thread swells when wet and blocks the needle holes. The needle holes also shrink around the thread. The canvas fabric also benefits from this because the cotton swells into the weave and the waterproof treatment settles within the fabric. Let the tent dry completely before doing it a second time. Always pack your tent away dry.

UNDERSTANDING WATERPROOFNESS

What is not covered by warranty!

OZtrail tents use waterproof and water repellent fabrics. However, with the addition of seams, zips and other desirable features a recreational tent will not be as waterproof as a car, house or other solid structures. The following are common examples of how water can enter a tent: -

Condensation - When warm moist air meets cooler air, condensation occurs. The tent/shelter fly forms an impermeable layer between the inside and outside conditions. The moisture inside the tent/shelter condenses on the fabric. Sometimes in cold conditions it appears that the fabric is leaking when in fact the cause is condensation. Condensation can be reduced if the tent/shelter is well ventilated.

Seams - All seams are factory tape sealed but could leak at webbing and guy line entry points and where there is multiple layers of fabric. If leakage at these points becomes a problem, simply use a recommended seam sealant. For both canvas and polyester fabrics rubbing a candle on the seam is a quick and easy fix.

Zips - All care is taken in the design to cover zips with rain flaps. At times wind driven rain could force water under the rain flaps and through the zips. To minimise this, make sure all doors and windows are closed with the rain flaps covering the zips.

Floor - If the ground is very wet or water pools under the floor, downward pressure of standing or kneeling on the floor could force water through the floor fabric. To prevent this, do not pitch the tent over hollows and make sure water drains away from the tent.

Structural Integrity - A perfectly pitched tent on perfectly flat ground is structurally strong and most waterproof. During prolonged periods of rain and wind it may be necessary to tighten guy lines and reset the tent pegs and attend to drainage around the tent. Sagging and incorrect pitching weakens the tent structure and could allow water to pool on the fly placing undue forces on the tent causing leaking and breakages.

Replacing shock-cord in tent poles

Use this procedure to replace broken or untied Shock-Cord:-

1. Start by cutting the Shock-Cord to 2/3's the length of the Tent Pole
2. Feed the cord through the first pole section and tie a double knot. The knot will catch on the end of the fibreglass pole inside the ferrule.
3. Stretch the Shock-Cord through each Pole Section keeping the cord stretched within the poles so you have enough relaxed cord to feed through the next Pole Section.
4. Once all Pole Sections are threaded, double check that the Shock Cord tension is not either too loose or too tight and then tie-off the free end.

Shock-cord can be purchased by the metre from Camping Stores or with Pole Repair Kits.

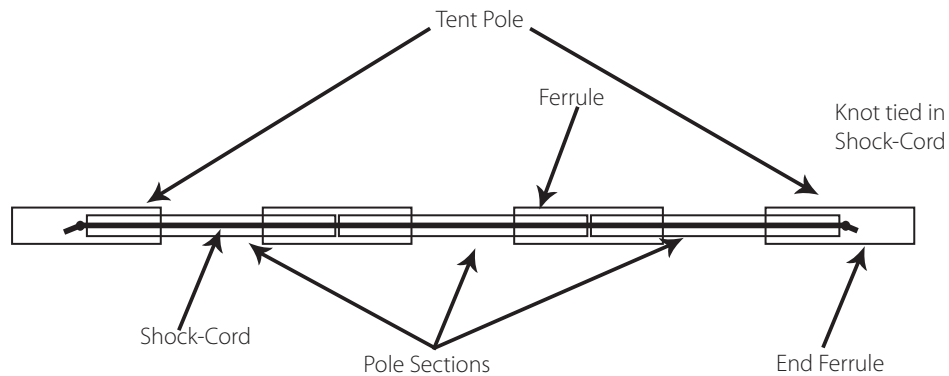

ZIPS

Reducing the risk of jamming fabric in the zip ~

- When using the zip, hold the pull-tab between your thumb and forefinger with your thumb facing you.
- As you are closing the zip clear the way in front and under the zip slider using the back of your hand, and cup the zip slider underneath with your remaining 3 fingers.

Use this action for opening or closing. Keep the fabric clear of the zip slider - zip and unzip slowly.

What to do when the zipper gets caught ~

- Pull the fabric bit by bit out of the slider. Do not try and pull all the fabric in one go. Do not force the slider, or use pliers on either the fabric or the zip.

If the slider does not close the zipper properly ~

- With use, the jaws of the zip slider can open ever so slightly. When this occurs the slider does not compress the zip teeth or coil together tightly enough and the zip bursts open or does not close.
- Undo the zip and with the slider at the end of the zip lightly crimp the jaws of the slider together. Try top to bottom axis first and then side to side axis.

Crimping A Zip-Slider

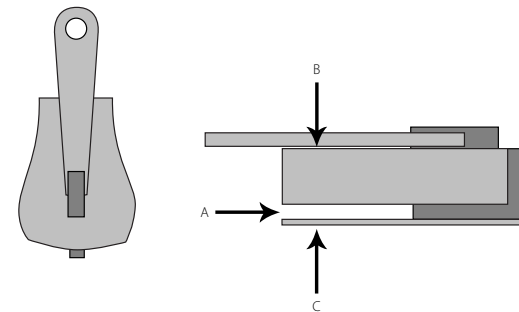

The most common reason why zips burst open is that the zip slider does not close the coil tightly enough. Metal fatigue and production variances cause the gap marked A to open up.

By simply 'crimping' the slider together at points B & C with a pair of pliers, this solves the problem most of the time. Crimping in other planes is worth a try if B & C does not work. This is to be done when the zip slider is still attached to the zip in the open position.

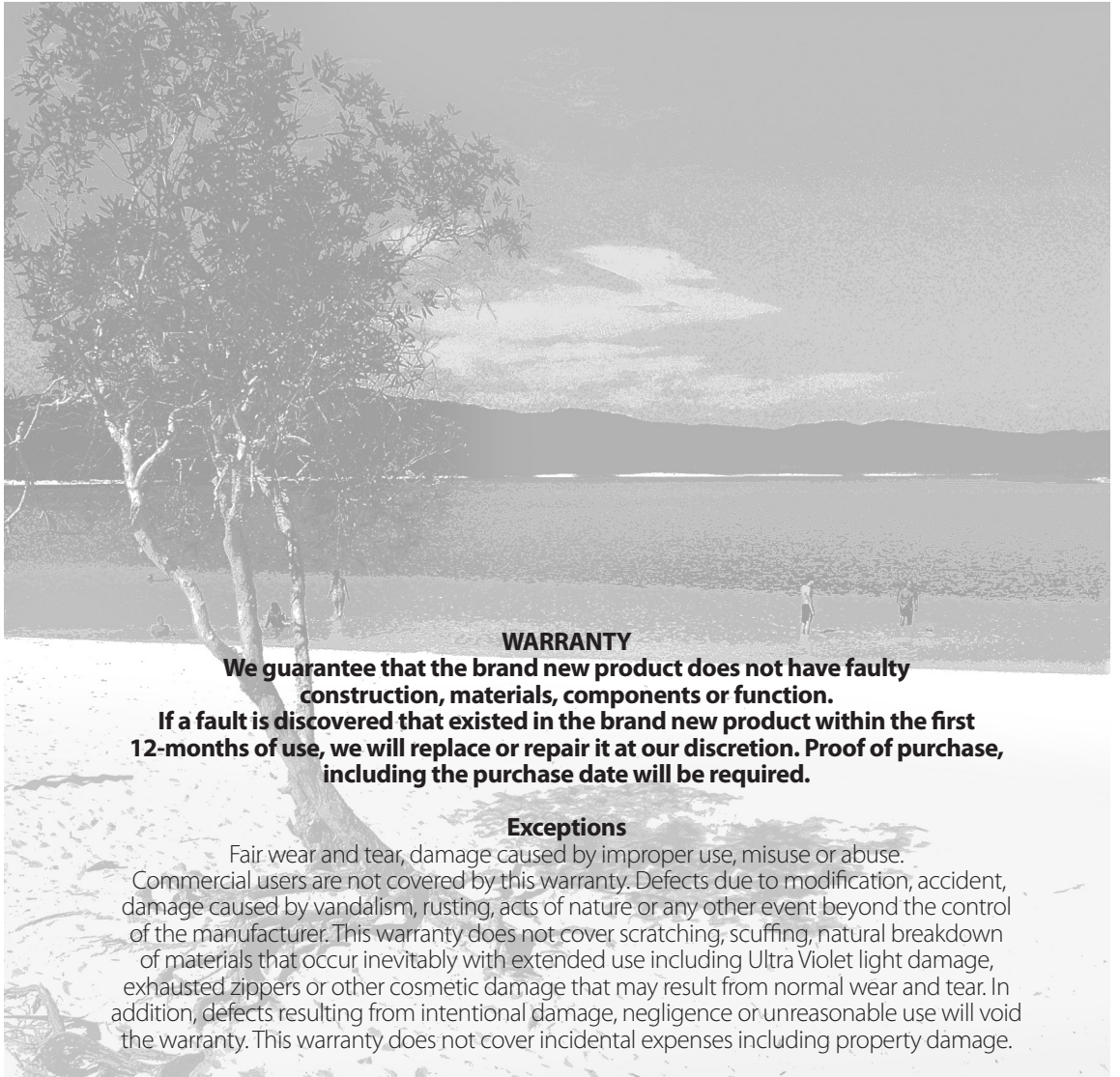

WARRANTY

We guarantee that the brand new product does not have faulty construction, materials, components or function.

If a fault is discovered that existed in the brand new product within the first 12-months of use, we will replace or repair it at our discretion. Proof of purchase, including the purchase date will be required.

Exceptions

Fair wear and tear, damage caused by improper use, misuse or abuse.

Commercial users are not covered by this warranty. Defects due to modification, accident, damage caused by vandalism, rusting, acts of nature or any other event beyond the control of the manufacturer. This warranty does not cover scratching, scuffing, natural breakdown of materials that occur inevitably with extended use including Ultra Violet light damage, exhausted zippers or other cosmetic damage that may result from normal wear and tear. In addition, defects resulting from intentional damage, negligence or unreasonable use will void the warranty. This warranty does not cover incidental expenses including property damage.



Imported by:

OZtrail Leisure Products

PO Box 1, Sumner Park QLD 4074

www.oztrail.com.au

Made in China