



J.E. ADAMS INDUSTRIES  
OWNERS MANUAL

MODEL# 29015 thru 29018  
29015UNI thru 29018UNI  
29015-2M thru 29018-2M

- PAGE 2            PRODUCT INFORMATION
- PAGE 3            SPECIFICATIONS
- PAGE 4            IMPORTANT SAFETY INFORMATION
- PAGES 4-5        INSTALLATION
- PAGES 5-8        PROGRAMMING
- PAGE 8            OPERATING
- PAGE 8            MAINTENANCE
- PAGES 9           TROUBLESHOOTING
- PAGES 10-14     PARTS LIST
- PAGE 15-19      WIRE DIAGRAMS

# **PRODUCT INFORMATION**

**Please take a moment to fill out the information below in order to aid us with any future sales or service inquiries. Model number and serial number information can be found on the serial tag located inside the control box and/or on the lower exterior of the can. Key number can be found on the tag that comes attached to the keys. There may be more than one key number depending on unit.**

**Please keep this information with your records.**

**MODEL#:** \_\_\_\_\_

**SERIAL#:** \_\_\_\_\_

**KEY NUMBER(S):** \_\_\_\_\_

**DATE PURCHASED:** \_\_\_\_\_

**DISTRIBUTOR:** \_\_\_\_\_

**J.E. Adams Industries  
1025 63<sup>rd</sup> Ave. S.W.  
Cedar Rapids, IA 52404  
1-800-553-8861  
[www.jeadams.com](http://www.jeadams.com)**

## SPECIFICATIONS:

Unit specifications: (29015 thru 29018)(29015UNI thru 29018UNI)

Voltage: 120v, 60Hz  
Amperage: (1)30 amp service is required for this unit  
Weight: 260 lbs with pallet attached

Vac specifications: (29015 thru 29018)(29015UNI thru 29018UNI)

Motors: (3) 120VAC Vacuum motor  
Fuses: (3) 10 amp inline fuses

Scent specifications: (29015 thru 29018)(29015UNI thru 29018UNI)

Compressor: (1) Thomas 120v, 1/12<sup>th</sup> hp compressor  
Solenoid: (3) Thomas peristaltic pump, 12VDC

---

Unit specifications: (29015-2m thru 29018-2M)

Voltage: 120v, 60Hz  
Amperage: (1)20 amp service is required for this unit  
Weight: 260 lbs with pallet attached

Vac specifications: (29015-2m thru 29018-2M)

Motors: (2) 120VAC Vacuum motor  
Fuses: (2) 10 amp inline fuses

Scent specifications: (29015-2m thru 29018-2M)

Compressor: (1) Thomas 120v, 1/12<sup>th</sup> hp compressor  
Solenoid: (3) Thomas peristaltic pump, 12VDC  
NOTE: "UNIT INTENDED FOR COMMECIAL USE ONLY"

NOTE: "UNIT INTENDED FOR COMMECIAL USE ONLY"

**Installation of 29000UNI, 29001UNI, 29002UNI and 29003UNI units are to be installed only by a qualified Unitec represented distributor or installer. Failure to do so may result in improper installation and may not be configured properly.**

## IMPORTANT SAFETY INSTRUCTIONS

When using an electrical appliance, basic precautions should always be followed, including the following:

### READ ALL INSTRUCTIONS BEFORE USING (THIS APPLIANCE)

**WARNING – To reduce the risk of fire, electric shock, or injury:**

- Do not use on wet surfaces.
- Use only as described in manual. Use only manufactures recommended attachments.
- Do not allow to be used as a toy. Close attention is necessary when used by or near children.
- Do not put any object into openings. Do not use with any opening blocked; keep free of dust, lint, hair and anything that may reduce air flow.
- Keep hair, loose clothing, fingers, and all parts of body away from openings and moving parts.
- Do not use to pick up flammable or combustible liquids, such as gasoline, or use in areas where they may be present.
- "Do not pick up anything that is burning or smoking, such as cigarettes, matches, or hot ashes."
- "DO not use without dust bag and/or filters in place."

### SAVE THESE INSTRUCTIONS

#### Installation Instructions:

- Determine location to mount unit ("**DANGER**" **"THIS EQUIPMENT INCORPORATES PARTS SUCH AS SWITCHES, MOTORS, OR THE LIKE THAT TEND TO PRODUCE ARCS OR SPARKS THAT CAN CAUSE AN EXPLOSION. WHEN LOCATED IN GASOLINE-DISPENSING AND SERVICE STATIONS INSTALL AND USE AT LEAST 20 FEET (6 M) HORIZONTALLY FROM THE EXTERIOR ENCLOSURE OF ANY DISPENSING PUMP AND AT LEAST 18 INCHES (450 MM) ABOVE A DRIVEWAY OR GROUND LEVEL."**)
- Run 30 amp service to that location (*NOTE UNIT HAS WIRE PROVIDED UNDERNEATH TO CONNECT INCOMING POWER SUPPLY*)
- **Grounding Instructions:** This appliance must be connected to a grounded metal, permanent wiring system; or an equipment-grounding conductor must be run with the circuit conductors and connected to the equipment-grounding terminal or lead on the appliance.
- Mount unit to location and use fig. 1 for mount pattern
- If unit is vault ready configuration see fig. 1 for mounting and fig. 2 for vault tube location.

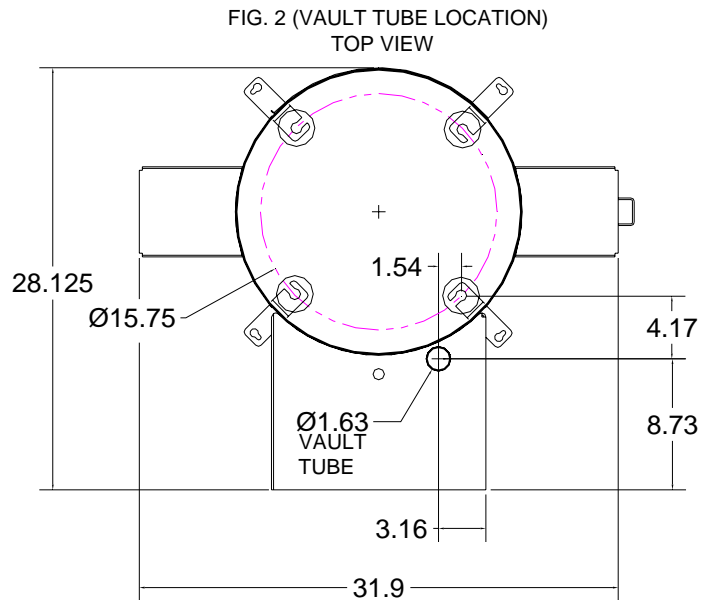
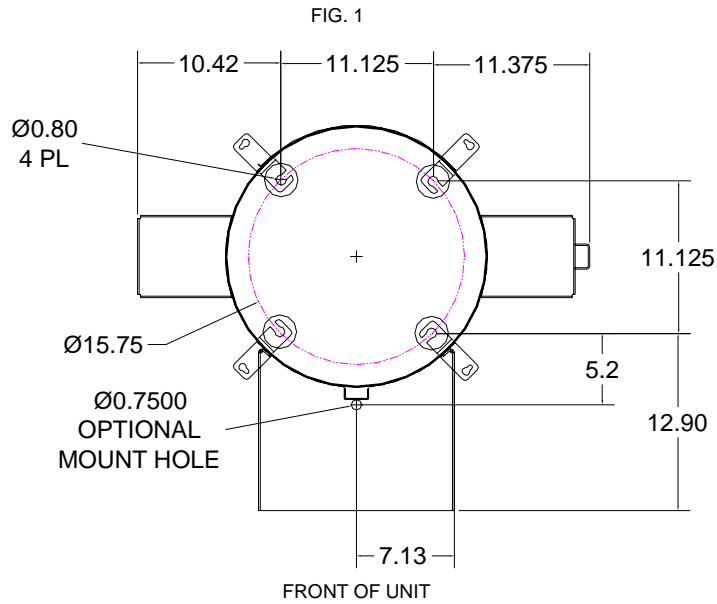

- Once unit has been installed use 5871B8 cap plugs supplied with unit to seal holes in canister bottom located in lower cleanout door. Then connect to power, pour scent into the bottles located in the bottom door and attach lids to appropriate bottles.
- Turn unit on and move to program instructions.

## Programming Instructions:

### Coin acceptor:

- No programming to acceptor needed if unit was purchased with the standard Imomex Z32 electronic acceptor (8149-92 our part number) is

pre-programmed to accept US quarters, .984 tokens, US \$1 coin and 1.073 token. Acceptor is pre-programmed before it is sent to J.E. Adams.

- If different acceptor was purchased, see additional literature sent along with unit for programming info.

Bill acceptor:

- Bill acceptor comes pre programmed from J.E. Adams and should not require any changes. If additional programming is needed to acceptors please refer to additional literature sent along with this unit.

Display:

- Unit may be programmed when received depending on information given at that the time of order.
- To program follow the instructions below.

Display programming with remote:

- 1) Press the red power button.
- 2) Timer will display 0000. At this time type in 4 digit access code. Note code will be 1234 until changed by customer.
- 3) Once code has been entered display should read ok. If display does not read ok, repeat step 1 and 2.
- 4) Press **CH +** button. Timer will display coin value. This should \$.25 and should not be changed.
- 5) Press the **CH +** button. Display will now read (**A: 30**) or may be a different time. (**A**) Will be the time per coin for the **VAC**. Set desired time per coin by using the **VOL -** to decrease or the **VOL +** to increase. Once time is entered move to next step.
- 6) Press the **CH +** button. Display will now read (**B: 30**) or may be different time. (**B**) Will be the time per coin for **TURBO**. Set desired time per coin by using the **VOL -** to decrease or the **VOL +** to increase. Once time is entered move to next step.
- 7) Press the **CH +** button. Display will now read **C**. **C** is not used.
- 8) Press the **CH +** button. Display will now read **D**. **D** is not used.
- 9) Press the **CH +** button. Display will now read (**B: 30**) or may be different time. (**B**) Will be the time per coin for **SCENT**. Set desired time per coin by using the **VOL -** to decrease or the **VOL +** to increase. Once time is entered move to next step.
- 10) Press the **CH +** button. Display will now read **F**. **F** is not used.
- 11) Press the **CH +** button. Display will now read (on A). This is the number of coins to start **VAC**. Use the **VOL -** and **VOL +** to adjust. Once this is done press the **CH+** button and repeat for (B) **TURBO** and (E) **SCENT**.
- 12) Press the **CH +** button. Display will read bonus time. Set if desired. See explanation at the end programming instructions.
- 13) Press the **CH +** button. Display will read debit mode. Set if desired. See explanation at the end programming instructions.
- 14) Press the **CH +** button. Display will read delayed start. Set if desired. See explanation at the end programming instructions.
- 15) Press the **CH +** button. Display will read **HLxx**. Set if desired. See explanation at the end programming instructions.

- 16) Press the **CH +** button. Display will read Restart off or restart on depending on what is set. Restart off will require a person to put in full amount after unit is turned off to reactivate. Restart on allows for additional coins to be put in the machine to keep unit running. To set use **VOL –** or **VOL +** to change.
- 17) Press the **CH +** button. Display will now read **STD** or **USER** or **MIX**. To make a custom message use **VOL +** button to scroll to USER. At this point press and hold **CH +** button until original message appears. At this time you may change the message simply by using the **VOL –** or **VOL +** buttons to change letters. **Once message has been entered you must put the symbol / at the end of message.** This will tell display that this is the end of the message.
- 18) Press the **CH +** button now 5 more times to exit programming.
- 19) Unit should now be programmed.

Program definitions:

- Bonus time settings:
  - Amount of time set in bonus time is added to regular time per coin/pulse (e.g. if you want to give 45 seconds for bonus time and your regular time per coin is 30 seconds, you would set bonus time at 00:15)
  - Bonus is disabled by setting bonus time to 00:00.
  - If bonus time is set to less than one minute, bonus time is added when bonus coin is reached and every coin after that until time expires.
  - If bonus time is set at 1:00 or more, bonus will be a “one time” bonus. Bonus time will only be added for bonus coin or multiples of bonus coin (e.g. 16<sup>th</sup> coin, 32<sup>nd</sup> coin, etc). Any other coin will on receive regular time per coin.
  - If bonus time is set to 99:00, when bonus coin is deposited, timer will show “-on-” and timer will continue to run until coin switch wire is shorted to ground by a loop detector or other switch closure for a minimum of two seconds.
- Debit and credit mode:
  - Debit mode: As coins are deposited display shows “\$1.75 MORE, \$1.50 MORE, \$1.25 MORE” etc. until start price is reached. Once start price is reached display switches to time accumulating until no more coins have been deposited.
  - Credit mode: As coins are deposited display shows money accumulating (\$.25, \$.50, \$.75 etc). If timer is also set to delayed start mode timer will continue to show money accumulating until no more coins have been deposited. If timer is set to instant start, as soon as start price is reached, timer will change to time counting down.

- Both mode: As coins are deposited display shows money accumulating (\$.25, \$.50, \$.75 etc). If start price is not reached, after 5 seconds timer will alternate between “add \$x.xx more” and amount of money already deposited.

#### Display programming with push button:

- Unit can be programmed using buttons that are located inside display. One is labeled **S2**, which is used to change from item to item. One is labeled **S1** which is used to set desired value. If you hold down **S1** this will cause numbers to decrease. If you repeatedly push **S1** numbers will increase.
- When programming with buttons use same instructions as remote except for the following. Where it says to press **CH +** use **S2** and where it says to use **VOL +** or **-** use **S1**.

### **Operating Instructions:**

- Select desired function.
- Insert coins or bills to start desired function.
- If Scent button is selected use rotary switch to the right of button to select desired scent.
- If other function is selected other than original selected item unit will recalculate timer based on the amount of money it takes to start the specific function.
- Once service is used, hang up hose.

### **Operating Instructions 29000UNI-29003UNI:**

- Select desired function.
- Insert coins or bills or swipe credit card to start desired function. When credit cards are selected swipe card and wait for activation.
- If shampoo/spot is selected, it is recommended that you vacuum before applying formula.
- If other function is selected other than original selected item unit will recalculate timer based on the amount of money it takes to start the specific function.
- Once service is used, hang up hose.

### **Maintenance:**

- Filter bags should be taken out weekly and shaken out. Also it might be a good idea to keep a new set of bags on hand so that once a month or longer you can take original bags out and wash them.
- Check vac hose for cracks on a weekly basis.
- Check scent bottles to assure that they are full.
- Clean canister with a stainless steel cleaner as needed.
- Check motor brushes approx. every 3 months for excessive wear. Motor brushes should be changed if they are shorter than ¼". ***Please disconnect power before doing this.***
- Check all shampoo lines and assembly for any signs of wear.
- All servicing of machine should be conducted by an authorized service representative.



## Troubleshooting:

### ***DISCONNECT POWER BEFORE SERVICING***

<b>Problem</b>	<b>Possible cause</b>	<b>Solution</b>
Unit is not powered	Breaker inside unit is not in the on position	Flip breaker on
Display is not powering	Breaker inside unit is not in the on position  Check transformer inside main power box in unit. Is there 24VAC at output terminal?	Flip breaker on  Replace transformer (8131-2)
Display reads "fail"	Coin acceptor putting out continuous pulse  Program in display may be lost	Press mode button on display. If fail does not go away replace coin acceptor. (8149-92) Reprogram display. If fail goes away and then comes back, replace battery in display.
Unit keeps blowing my breaker from my incoming power source	Inadequate wire size supplied to machine  Wrong size breaker	Call electrician and install proper wire size for 30amp service versus length or run.  Install correct breaker( only use wire size that is adequate to handle 30 amp breaker)
Fuses for vac motors keep blowing.	Inadequate wire size supplied to machine  Motor brushes may be bad or too short	Call electrician and install proper wire size for 30amp service versus length or run.  Replace motor brushes (8055BR)
Unit has lost suction	Vac hose clogged  Filter bags need cleaned  Vac hose is damaged  Cleanout door gaskets torn or worn	Clean out debris from vac hose  Clean out filter bags or replace (8076)  Replace vac hose (2036)  Replace gaskets (8159)
Unit has shut down For no apparent reason	This unit has a reset thermal limiter in the compressor. Unit may have shut down due to excessive heat	Turn off power to the machine and wait for a period of 5 minutes. Reapply power and activate machine.

PART NO. 29000-250A

NOTE:  
1) ASSEMBLY ALL ITEMS AS SHOWN.

- 2) USE WIRE ASSEMBLY 00-CB-CONTROL PANEL TO WIRE THIS CONTROL PANEL ASSEMBLY. THE 00-CB-CONTROL PANEL IS LOCATED IN THE 00-CB-WIRE KIT CABLE PACKAGE PURCHASED FROM TIMBERLINE. THE 00-CB-WIRE KIT IS CALLED OUT UNDER THE 29000 TOP LEVEL ASSEMBLY.
- 3) USE WIRE DIAGRAM S29000\_CB\_CONTROL.

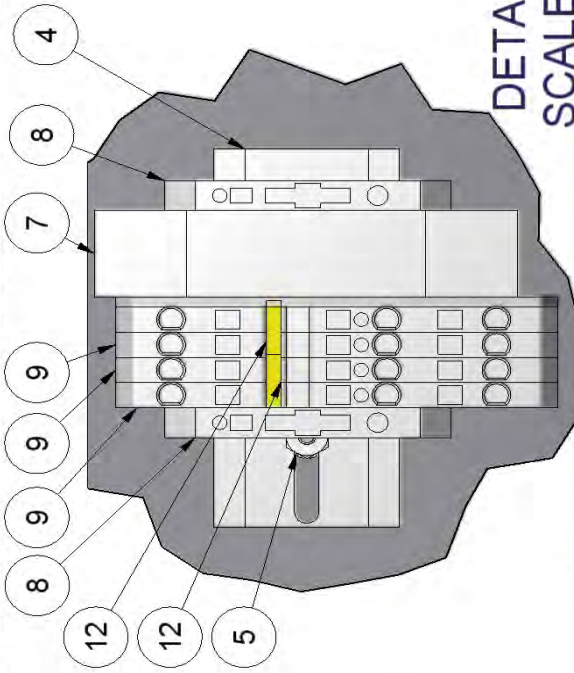
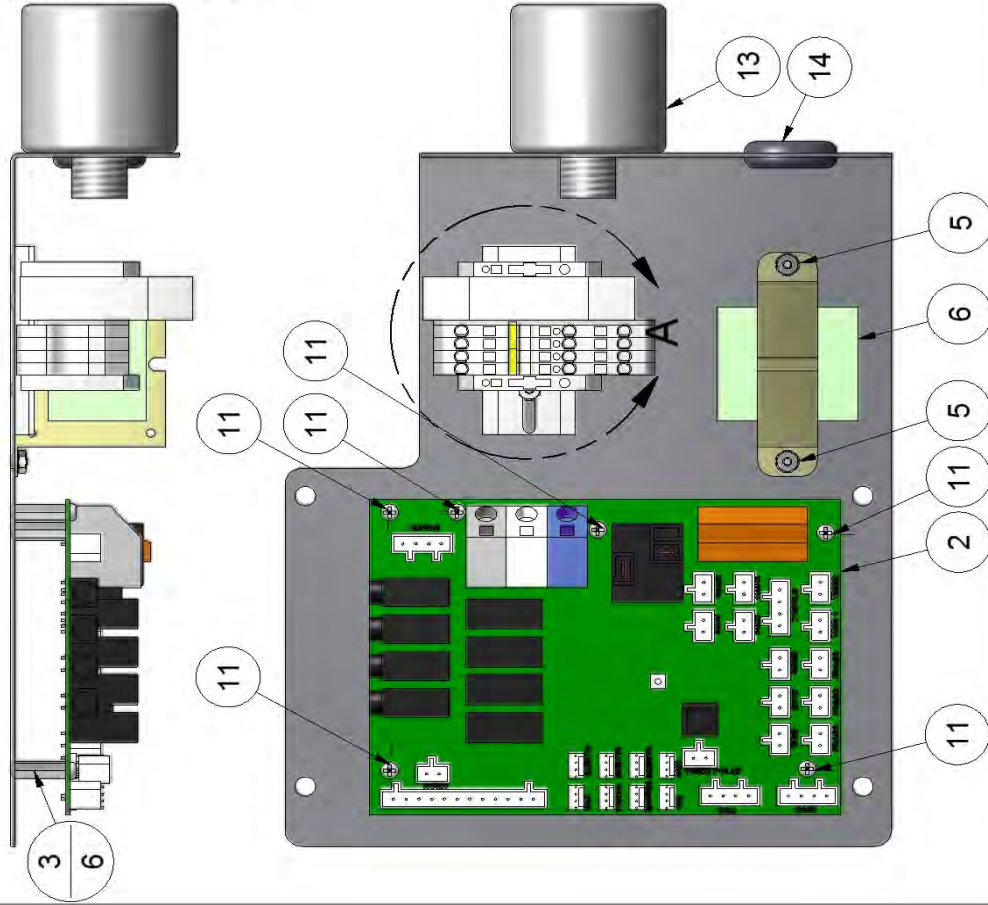

DETAIL A  
SCALE 3 / 4

BILL OF MATERIALS			
ITEM	PART NUM	DESCRIPTION	QTY
1	29000-250W	BRACKET, CONTROL PLATE WELDMENT	1
2	CB-5002	CIRCUIT BOARD, MULTI-FUNCTION UNITS	1
3	5000D6	#6-32 x .75 FxF STANDOFF	6
4	28000-129	DIN RAIL CUT TO 3"	1
5	8157	NUT, #6-32 KEPP NUT STAINLESS	4
6	8131-2	TRANSFORMER, 110/220-24 1.66A	1
7	28000-128	MAGNETIC CIRCUIT BREAKER	1
8	28000-124	TERMINAL BLOCK STOP	2
9	28000-800	33A DIN BLOCK, 10 GA.	4
10	28000-820	END BARRIER, GREY	1
11	5662D5	6-32 x 3/8 PHIL. PAN -MACHINE SCREW	6
12	28000-155	JUMPER	2
13	29000-302-R	LIGHTNING ARRESTOR, LA302-R	1
14	5639D6	RUBBER GROMMET	1

TITLE		CONTROL PANEL ASSEMBLY W/CB	
MATERIAL	UNSPECIFIED TOLERANCES	SCALE	CEDAR RAPIDS, IOWA
1 PL ±.030	2 PL ±.010	DRAWN BY	CHAD K.
3 PL ±.003	ANGLE ±1.0	DATE	2/16/2009
REV.		PART NO. 29000-250A	
DESCRIPTION		THIS DOCUMENT SHALL NOT BE REPRODUCED NOR SHALL THE INFORMATION THEREIN BE USED BY OR DISCLOSED TO OTHERS EXCEPT AS AUTHORIZED BY J.E. ADAMS INDUSTRIES	



PART NO. 29015-7CBA

BILL OF MATERIALS

ITEM	PART NUMB	DESCRIPTION	QTY	ITEM	PART NUMB	DESCRIPTION	QTY
9	8000-15	BIG DIXMOR DISPLAY	1	1	29015-7CB	CONTROL DOOR WELDMENT- SCENT	1
10	8726	PUSH BUTTON	1	W			
13	8659-24	LOCK COLLAR -SS	3	2	8149-92	IMONEX COIN ACCEPTOR - ELECTRIC	1
14	29000-25	HORN BRACKET	1	3	8157	NUT, #6-32 KEPP NUT STAINLESS	4
16	29000-199	GASKET, VALIDATOR MOUNT	1	4	29000-24	DISPLAY BRACKET	2
18	8958-2	MEDECO SCREW LOCK	3	5	5629D2	#8 x 1/2 SELF TAPPING SCREW	4
19	00-CB-D-05	BLUE PUSH BUTTON	5	6	5611D2	NUT, 10-24 UNC KEPP-ZINC	4
				7	8000-11	ALARM, LAST COIN ALERT	1
				8	29000-34	LEXAN WINDOW	1

BILL OF MATERIALS

ITEM	PART NUMB	DESCRIPTION	QTY
1	29015-7CB	CONTROL DOOR WELDMENT- SCENT	1
2	8149-92	IMONEX COIN ACCEPTOR - ELECTRIC	1
3	8157	NUT, #6-32 KEPP NUT STAINLESS	4
4	29000-24	DISPLAY BRACKET	2
5	5629D2	#8 x 1/2 SELF TAPPING SCREW	4
6	5611D2	NUT, 10-24 UNC KEPP-ZINC	4
7	8000-11	ALARM, LAST COIN ALERT	1
8	29000-34	LEXAN WINDOW	1

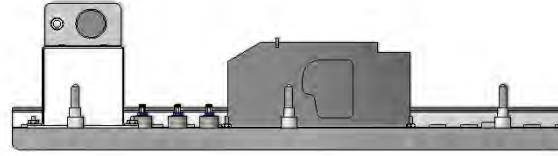
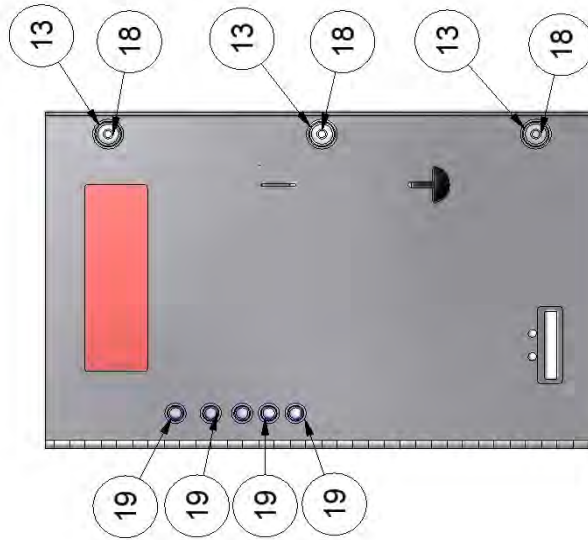
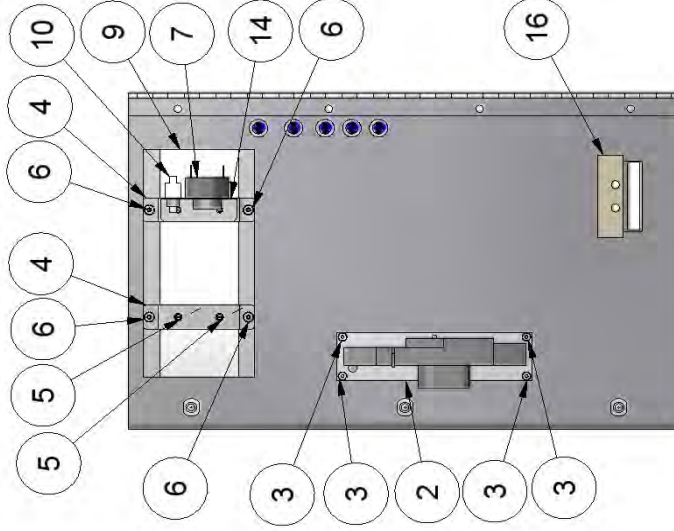

TITLE SCENT VAC DOOR ASSEMBLY, W/CB

UNSPECIFIED TOLERANCES	MATERIAL	CEDAR RAPIDS, IOWA <b>J.E. ADAMS INDUSTRIES, LTD.</b>
1 PL ±.030	SCALE	
2 PL ±.010	DRAWN BY CHAD K.	
3 PL ±.003	DATE 4/2/2009	
ANGLE ±1.0°		REV. PART NO. 29015-7CBA

REV	NO.	DESCRIPTION	DATE	BY
		THIS DOCUMENT SHALL NOT BE REPRODUCED NOR SHALL THE INFORMATION THEREIN BE USED BY OR DISCLOSED TO OTHERS EXCEPT AS AUTHORIZED BY J.E. ADAMS INDUSTRIES		

PART NO. **29015-29A-2**

**BILL OF MATERIALS**

ITEM	PART NUMBER	DESCRIPTION	QTY
1	29000-29W-1	PUMP BRACKET WELDMENT	1
2	3100	RUBBER TUBING	54"
3	3101	1/8 TUBING	2.25"
4	5603D15	NUT, 4-40 UNC KEPS	6
5	5710D40	#4-40 X 3/8 PHIL PHMS SS	6
6	8802-1	LOCKING CAP	3
7	9500-43	THOMAS PERISTALTIC PUMP- 12VDC	3
8	9500-47	LINE WEIGHT	3

- NOTE:
- ASSEMBLY ALL ITEMS AS SHOWN.
  - USE WIRE ASSEMBLY 00-CB-PUMP TO WIRE THIS PUMP ASSEMBLY. THE 00-CB-PUMP IS LOCATED IN THE 00-CB- WIRE KIT CABLE PACKAGE PURCHASED FROM TIMBERLINE. THE 00-CB-WIRE KIT IS CALLED OUT UNDER THE 29015 TOP LEVEL ASSEMBLY.
  - USE WIRE DIAGRAM S29015\_CB\_PUMP-BRUSH.
  - SOLDER LEADS TO PUMPS AS SHOWN ON S29015\_CB\_PUMP

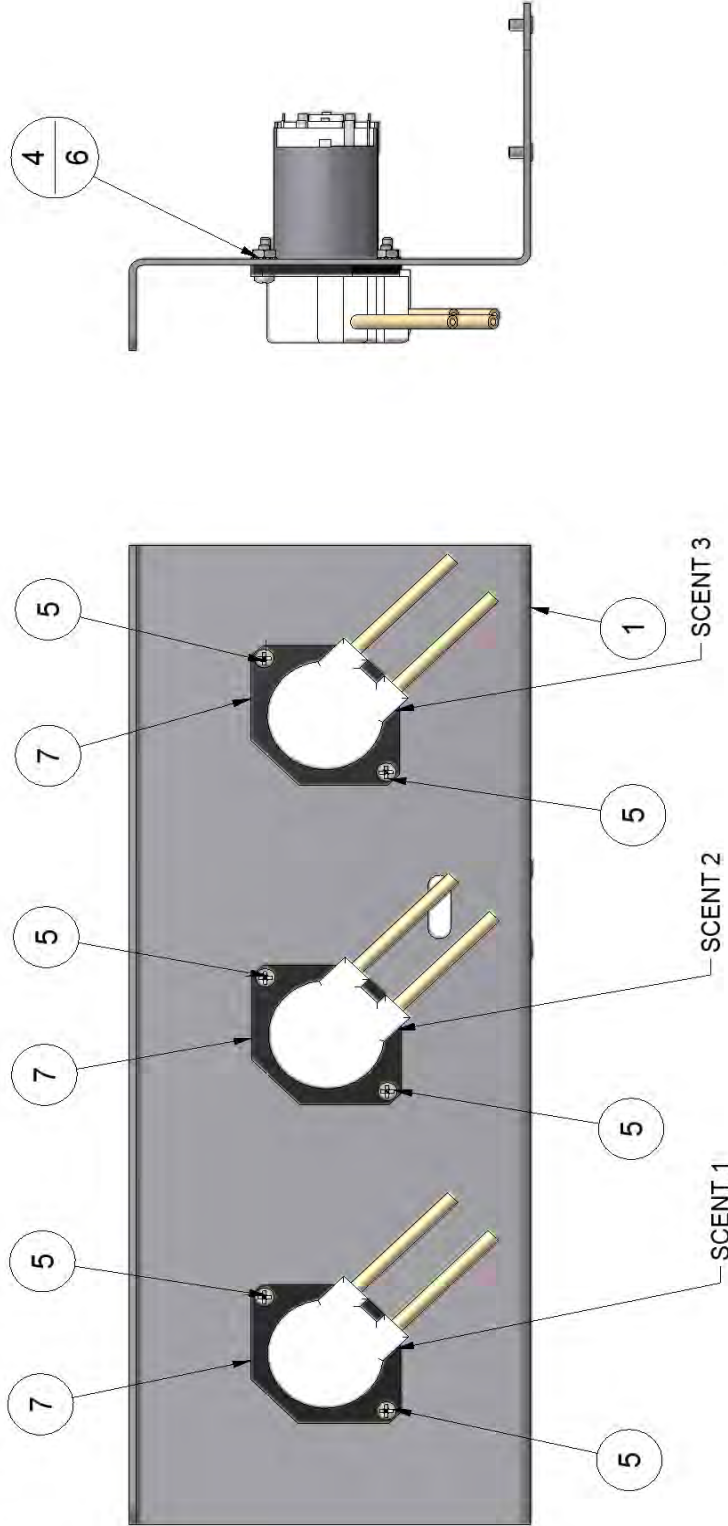

TITLE

**THOMAS PUMP ASSEMBLY**

UNSPECIFIED TOLERANCES	MATERIAL
1 PL ±.030	SCALE
2 PL ±.010	DRAWN BY CHAD K.
3 PL ±.003	DATE 4/2/2009
ANGLE ±1.0°	



PART NO. **29015-29A-2**

REV	NO.	DESCRIPTION	DATE	BY
		THIS DOCUMENT SHALL NOT BE REPRODUCED NOR SHALL THE INFORMATION THEREIN BE USED BY OR DISCLOSED TO OTHERS EXCEPT AS AUTHORIZED BY J.E. ADAMS INDUSTRIES		

**29015**

BILL OF MATERIALS		BILL OF MATERIALS	
ITEM	PART NUM	DESCRIPTION	QTY
31	5647D8	RIVET 3/16	14
32	5871B8	CAP PLUG	8
33	6082	9 X 12 BAG	1
34	8055	MOTOR, AMETEK 115V	3
35	8057	MOTOR GASKET	3
36	8076	FLITER BAG	4
37	8108	#10 x 1/2 TAP SCREW	6
38	8130-6	MARS 110V BILL VALIDATOR	1
39	8153-1	LATCH	4
40	8159	DOOR GASKET	2
41	8182	DISCONNECT POWER DECAL	4
42	8306	24" PLASTIC DOME	1
43	8615-5W	CLEANOUT DOOR	2
44	8630	CARDBOARD BOX	1
45	8659-24	LOCK COLLAR -SS	2
46	8857	WILD CHERRY SCENT	1
47	8859	NEW CAR SCENT	1
48	8865	VANILLA SCENT	1
49	8898-1	FRAGRANCE GUN ASSY. .750 OD HOSE	1
50	8925	FLOURESCENT BULB	3
51	8939	PALLET	1
52	8958-1	MEDECO SCREW LOCK	2
53	8958-2	MEDECO SCREW LOCK	2
54	B5996-010	10AMP FUSE	3
55	B5997-001	FUSE HOLDER	3

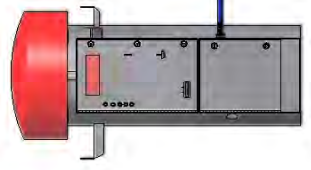

BILL OF MATERIALS		BILL OF MATERIALS	
ITEM	PART NUM	DESCRIPTION	QTY
1	2036	2" X 15' VAC HOSE	1
2	2058	CLAW AND CUFF ASSEMBLY	1
3	28000-36	MOTOR MOUNT	6
4	28000-40	PLASTIC CONTAINER	3
5	29000-14W	BOTTOM DOOR WELDMENT	1
6	29000-250A	CONTROL PANEL ASSEMBLY W/CB	1
7	29000-30A	LIGHT BRACKET ASSEMBLY	1
8	29000-37A	COMPRESSOR ASSEMBLY	1
9	29000-44W	VALIDATOR BOX WELDMENT	1
10	29000-45W	VALIDATOR FACEPLATE WELDMENT	1
11	29000-47W	COIN BOX ENCLOSURE WELDMENT	1
12	29000-52W	COIN BOX WELDMENT	1
13	29000-59	VALIDATOR FACEPLATE HANDLE	1
14	29015-1W	CANISTER WELD COMPLETE	1
15	29015-29A-2	THOMAS PUMP ASSEMBLY	1
16	29015-7CBA	SCENT VAC DOOR ASSEMBLY, W/CB	1
17	29015Y-KIT-	COMPLETE DECAL SET	1
18	5601D1	1/4-20 x 1/2 HHCS-ZINC PLATED	6
19	5601D4	1/4-20 x 3/4 HHCS-SS	4
20	5603D11	1/2 Std NC Nylock Nut	2
21	5603D2	1/4 Std NC Nylock Nut	4
22	5603D5	1/4 Std NC Nylock Nut	8
23	5603D9	10 Std NF Nylock Nut	2
24	5606D10	WASHER, FLAT 1/2 SAE	2
25	5611D4	NUT, 5/16-18 UNC KEPP- SS	3
26	5636D1	#10-24 PHIL. PAN HEAD SCREW	2
27	5639D4	RUBBER GROMMET	2
28	5639D9	ISOLATION MNT, 30 DUR NEOPRENE, 1/4-20	4
29	5644D1	CAGE NUT	5
30	5647D2	RIVET 1/8'	16

**VAC- TURBO- SCENT, W/CB**

UNSPECIFIED TOLERANCES  
 1 PL ±.030  
 2 PL ±.010  
 3 PL ±.003  
 ANGLE ±1.0°

MATERIAL  
 SCALE  
 DRAWN BY CHAD K.  
 DATE 4/3/2009

CEDAR RAPIDS, IOWA

J.E. ADAMS INDUSTRIES, INC.

PART NO. **29015**

REV NO. DESCRIPTION DATE BY

THIS DOCUMENT SHALL NOT BE REPRODUCED NOR SHALL THE INFORMATION THEREIN BE USED BY OR DISCLOSED TO OTHERS EXCEPT AS AUTHORIZED BY J.E. ADAMS INDUSTRIES

PART NO.

29015

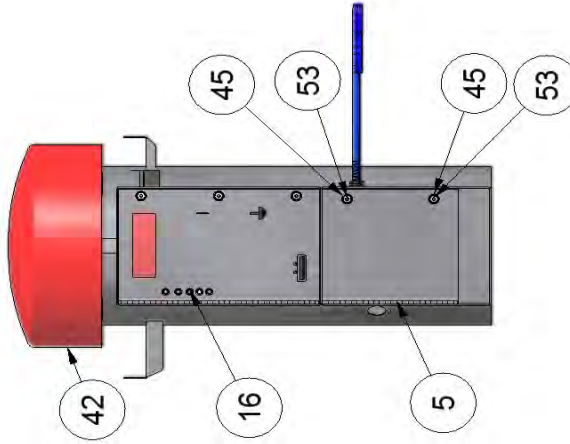
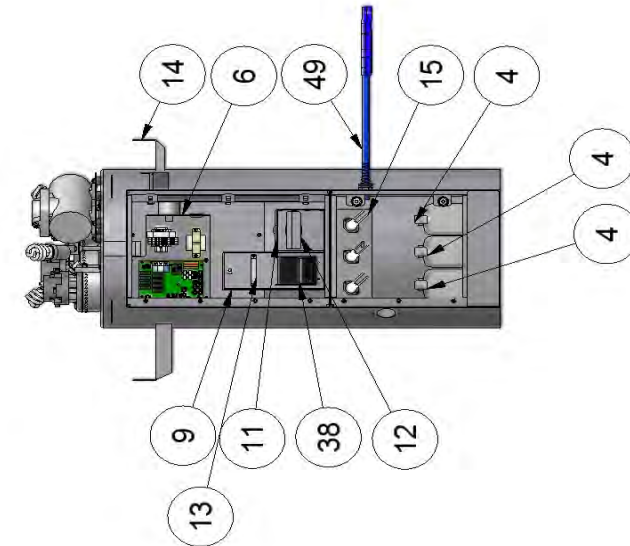
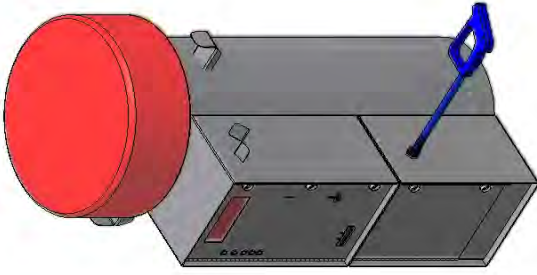
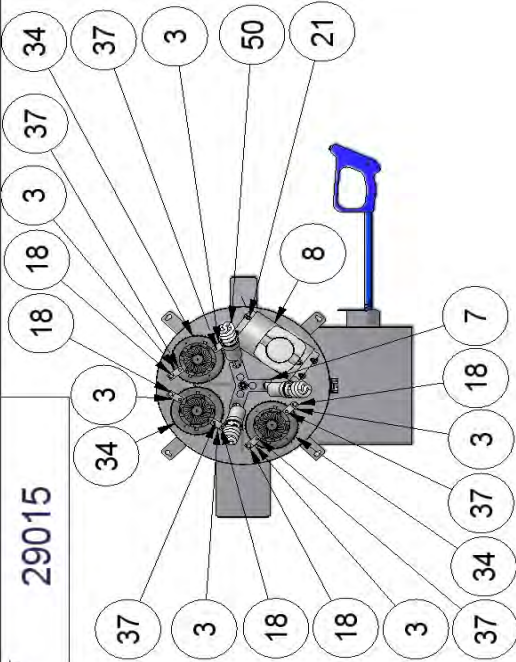

TITLE

VAC-TURBO-SCENT, W/CB

UNSPECIFIED MATERIAL

TOLERANCES

1 PL ±.030

2 PL ±.010

3 PL ±.003

ANGLE ±1.0°

SCALE

DRAWN BY

DATE

CHAD K.

4/3/2009

DESCRIPTION

DATE

BY

THIS DOCUMENT SHALL NOT BE REPRODUCED NOR SHALL THE INFORMATION THEREIN BE USED BY OR DISCLOSED TO OTHERS EXCEPT AS AUTHORIZED BY J.E. ADAMS INDUSTRIES

REV

NO.

DESCRIPTION

DATE

BY

THIS DOCUMENT SHALL NOT BE REPRODUCED NOR SHALL THE INFORMATION THEREIN BE USED BY OR DISCLOSED TO OTHERS EXCEPT AS AUTHORIZED BY J.E. ADAMS INDUSTRIES

REV

NO.

DESCRIPTION

DATE

BY

THIS DOCUMENT SHALL NOT BE REPRODUCED NOR SHALL THE INFORMATION THEREIN BE USED BY OR DISCLOSED TO OTHERS EXCEPT AS AUTHORIZED BY J.E. ADAMS INDUSTRIES

REV

NO.

DESCRIPTION

DATE

BY

THIS DOCUMENT SHALL NOT BE REPRODUCED NOR SHALL THE INFORMATION THEREIN BE USED BY OR DISCLOSED TO OTHERS EXCEPT AS AUTHORIZED BY J.E. ADAMS INDUSTRIES

REV

NO.

DESCRIPTION

DATE

BY

THIS DOCUMENT SHALL NOT BE REPRODUCED NOR SHALL THE INFORMATION THEREIN BE USED BY OR DISCLOSED TO OTHERS EXCEPT AS AUTHORIZED BY J.E. ADAMS INDUSTRIES

REV

NO.

DESCRIPTION

DATE

BY

THIS DOCUMENT SHALL NOT BE REPRODUCED NOR SHALL THE INFORMATION THEREIN BE USED BY OR DISCLOSED TO OTHERS EXCEPT AS AUTHORIZED BY J.E. ADAMS INDUSTRIES

REV

NO.

DESCRIPTION

DATE

BY

THIS DOCUMENT SHALL NOT BE REPRODUCED NOR SHALL THE INFORMATION THEREIN BE USED BY OR DISCLOSED TO OTHERS EXCEPT AS AUTHORIZED BY J.E. ADAMS INDUSTRIES

REV

NO.

DESCRIPTION

DATE

BY

THIS DOCUMENT SHALL NOT BE REPRODUCED NOR SHALL THE INFORMATION THEREIN BE USED BY OR DISCLOSED TO OTHERS EXCEPT AS AUTHORIZED BY J.E. ADAMS INDUSTRIES

REV

NO.

DESCRIPTION

DATE

BY

THIS DOCUMENT SHALL NOT BE REPRODUCED NOR SHALL THE INFORMATION THEREIN BE USED BY OR DISCLOSED TO OTHERS EXCEPT AS AUTHORIZED BY J.E. ADAMS INDUSTRIES

REV

NO.

DESCRIPTION

DATE

BY

CEDAR RAPIDS, IOWA



PART NO. 29015

REV.

CHAD K.

4/3/2009

DATE

BY

DESCRIPTION

THIS DOCUMENT SHALL NOT BE REPRODUCED NOR SHALL THE INFORMATION THEREIN BE USED BY OR DISCLOSED TO OTHERS EXCEPT AS AUTHORIZED BY J.E. ADAMS INDUSTRIES

REV

NO.

DESCRIPTION

DATE

BY

THIS DOCUMENT SHALL NOT BE REPRODUCED NOR SHALL THE INFORMATION THEREIN BE USED BY OR DISCLOSED TO OTHERS EXCEPT AS AUTHORIZED BY J.E. ADAMS INDUSTRIES

DISPLAY

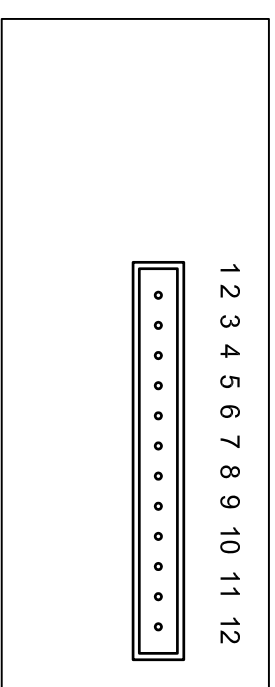

PLUG INTD  
DISPLAY  
CONNECTOR

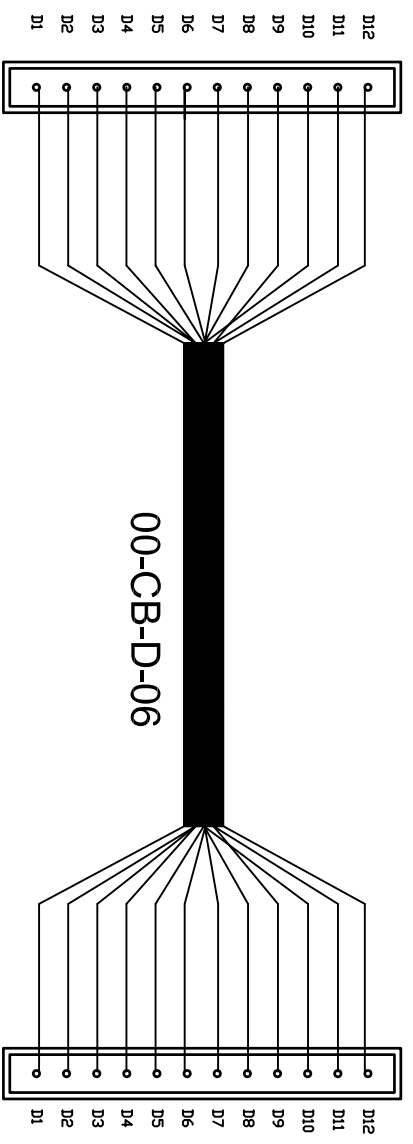

PLUG INTD  
CONNECTOR (J7)

PUSH  
BUTTON

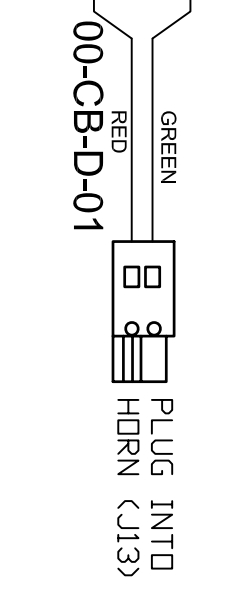
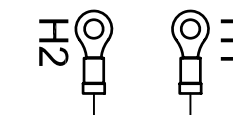
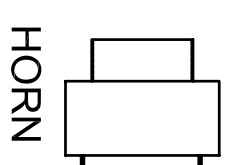
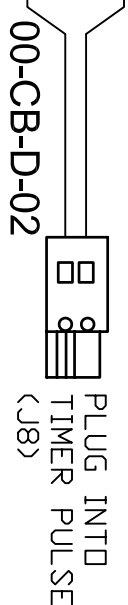
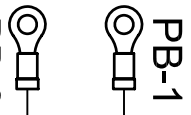
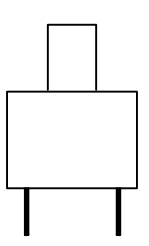

ATTACH TO  
VALIDATOR  
FACPLATE



00-CB-D-07



ATTACH TO  
VALIDATOR  
BOX

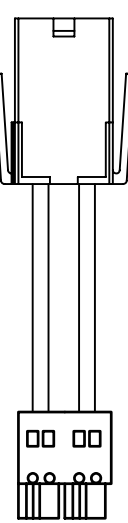
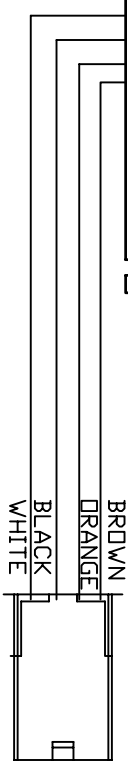
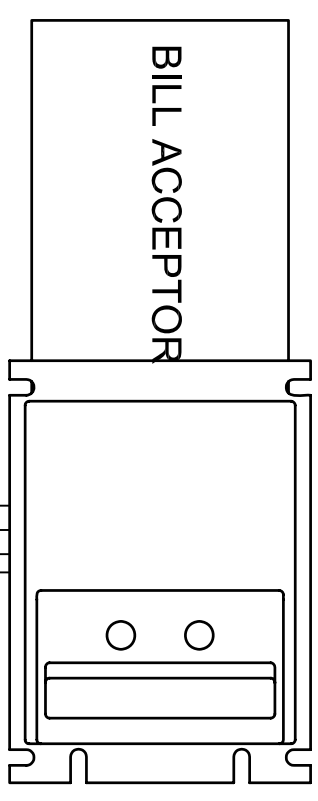

00-CB-D-04

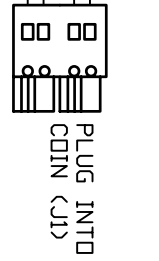
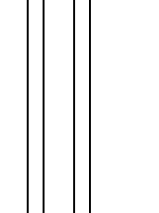
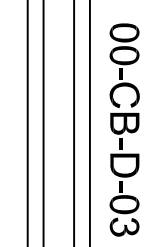
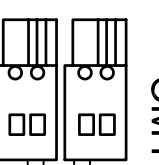
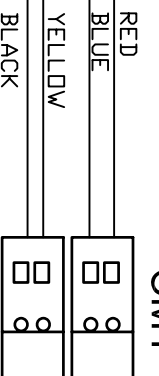
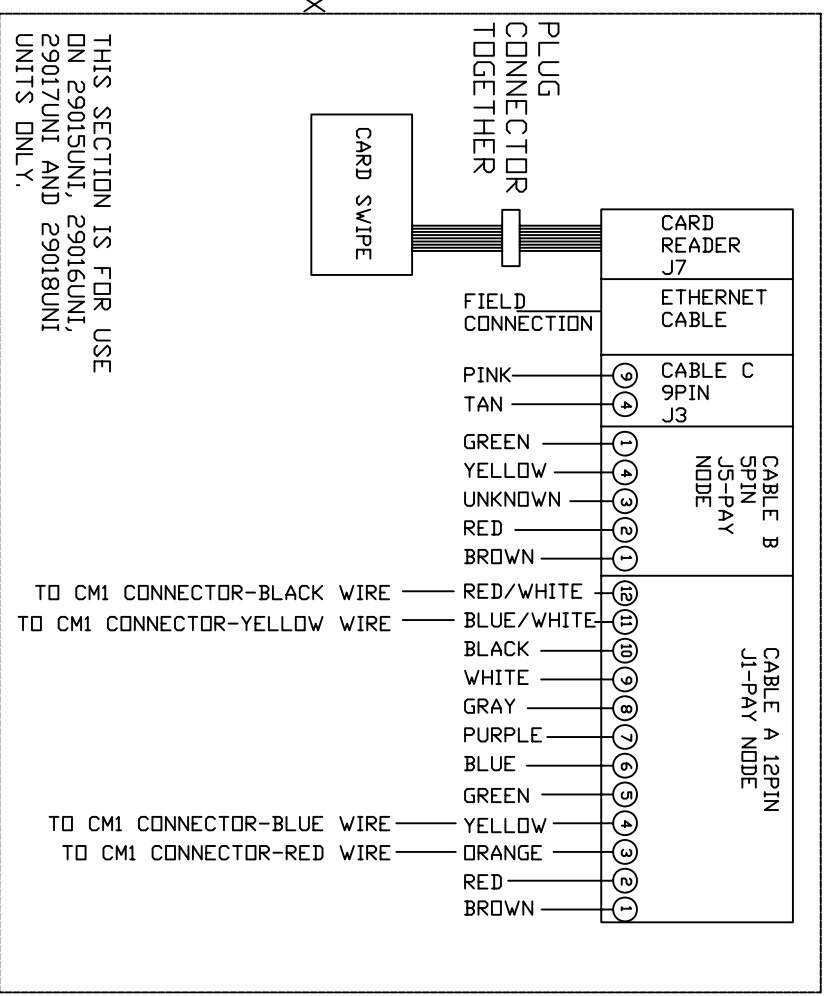

00-CB-D-03

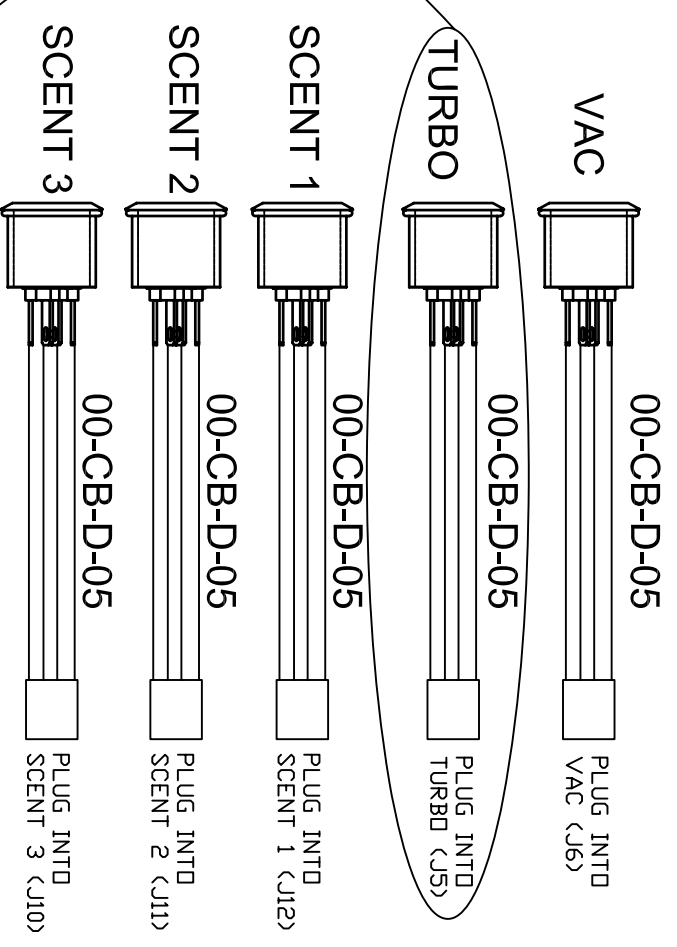

NOT USED ON 29015-2M  
THRU 290018-2M MODELS

REV	NO.	DESCRIPTION	DATE	BY
B	5895	ADDED INFORMATION FOR 29015-2m THRU 29018-2m	5-20-10	CK
A	5595	ADDED UNITEC CC INFO	2-24-10	CK

THIS DOCUMENT SHALL NOT BE  
REPRODUCED NOR SHALL THE  
INFORMATION THEREIN BE USED  
BY OR DISCLOSED TO OTHERS  
EXCEPT AS AUTHORIZED BY  
J.E. ADAMS INDUSTRIES

PART No. S29015\_CB\_D00R

CEDAR RAPIDS, IOWA  
J.E. ADAMS INDUSTRIES

UNSPECIFIED  
TOLERANCES  
1 PL ±.030  
2 PL ±.010  
3 PL ±.003  
ANGLE ±1.0°

TITLE			
CONTROL DOOR WIRING 29015 SERIES UNIT			
DRAWN	DATE	SCALE	REL. FOR PROD.
CK	3-2009	-	-
MATERIAL	PART No.	SCALE	REV. LEVEL
-	S29015_CB_D00R	-	B

CIRCUIT BOARD

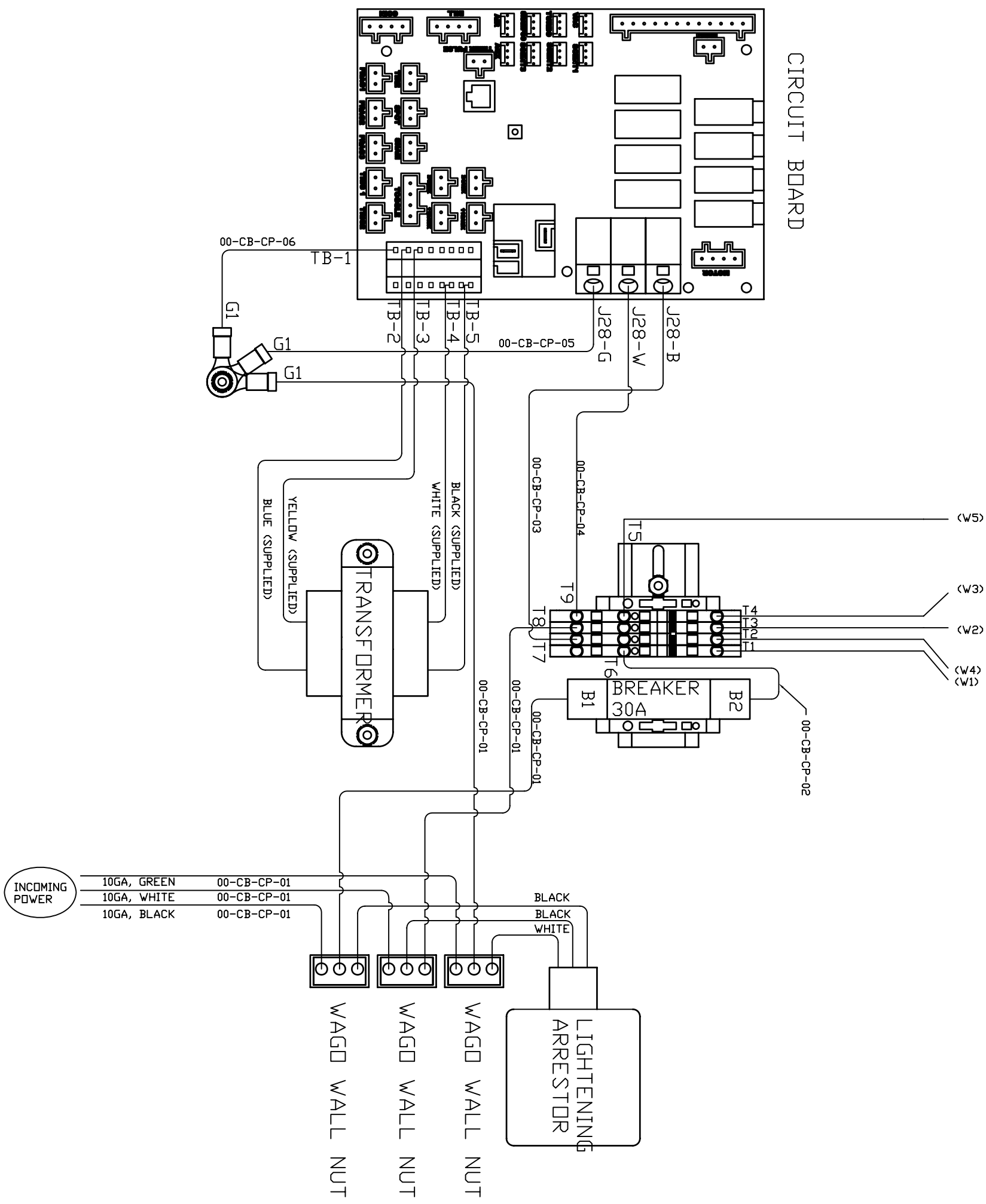

REV	NO.	DESCRIPTION	DATE	BY

THIS DOCUMENT SHALL NOT BE REPRODUCED NOR SHALL THE INFORMATION THEREIN BE USED BY OR DISCLOSED TO OTHERS EXCEPT AS AUTHORIZED BY J.E. ADAMS INDUSTRIES

PART NO. S29015\_CB\_CONTROL



UNSPECIFIED TOLERANCES  
 1 PL ±.030  
 2 PL ±.010  
 3 PL ±.003  
 ANGLE ±1.0°

TITLE		DATE		SCALE		REL. FOR PROD.		REV. LEVEL	
CONTROL PANEL WIRING 29015 SERIES UNITS		3-2009		-		-		-	
DRAWN BY	CK	DATE	3-2009	SCALE	-	REL. FOR PROD.	-	REV. LEVEL	-
MATERIAL	-	PART NO.	S29015_CB_CONTROL	SCALE	-	REL. FOR PROD.	-	REV. LEVEL	-



PART NO. S29015\_CB\_TDP

NOTE:  
 1) VAC 3 AND FUSE  
 NOT USED ON  
 MODELS 29015-2M  
 THRU 29018-2M.

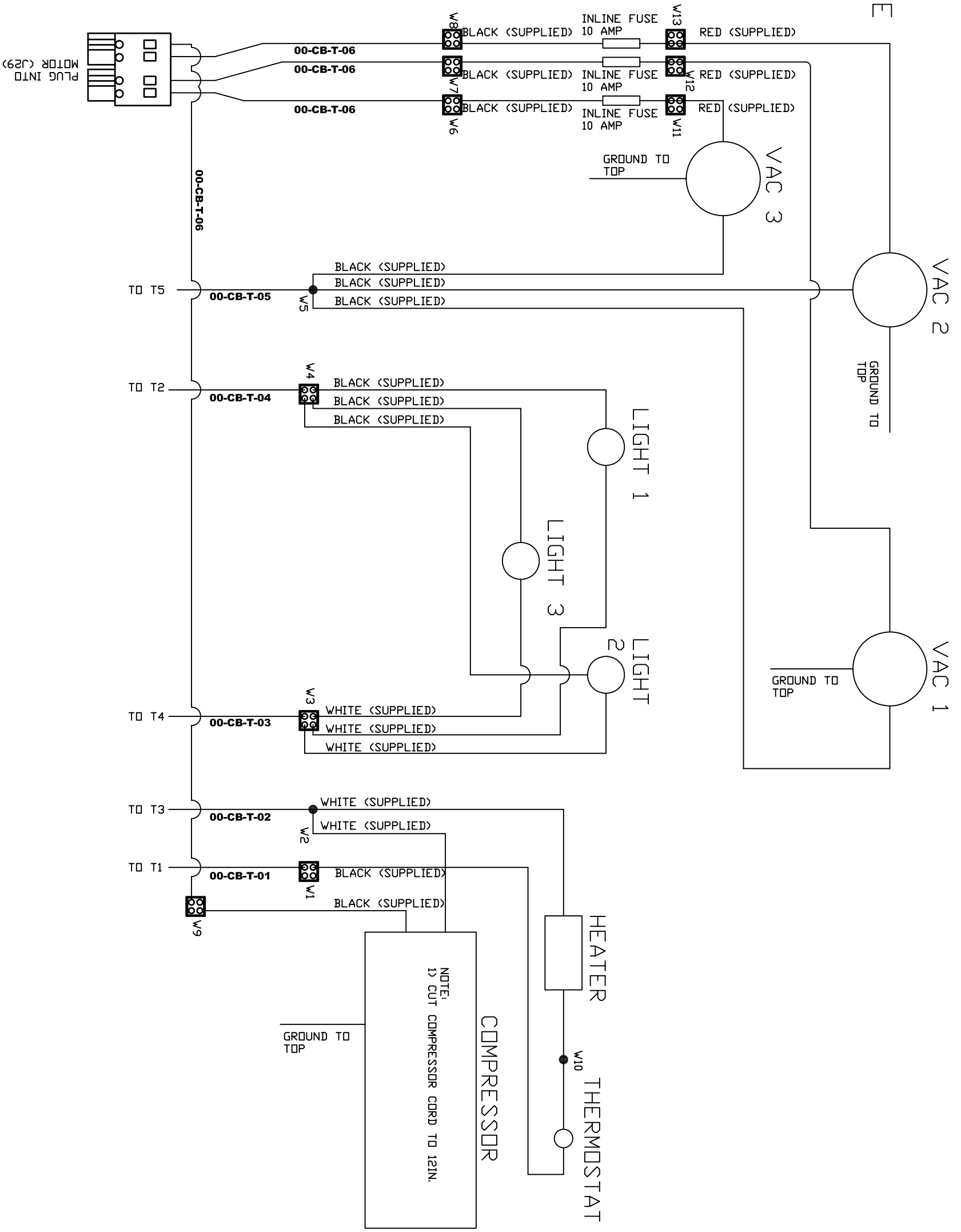

REV	NO.	DESCRIPTION	DATE	BY
A	5896	ADDED INFORMATION FOR 29015-2M THRU 29018-2M	5-20-10	CK

THIS DOCUMENT SHALL NOT BE REPRODUCED NOR SHALL THE INFORMATION THEREIN BE USED BY OR DISCLOSED TO OTHERS EXCEPT AS AUTHORIZED BY J.E. ADAMS INDUSTRIES

PART NO. S29015\_CB\_TDP

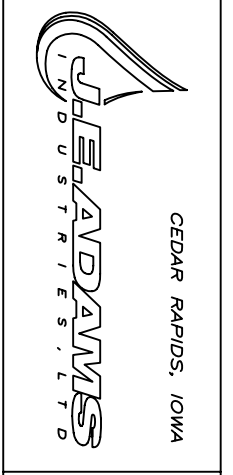

UNSPECIFIED TOLERANCES  
 1 PL ±.030  
 2 PL ±.010  
 3 PL ±.003  
 ANGLE ±1.0°

TITLE		UNIT TOP WIRING 29000 SERIES UNIT	
DRAWN BY	CK	DATE	3-2009
MATERIAL	-	PART NO.	S29015_CB-TDP
SCALE	-	REL. FOR PROD.	-
REV. LEVEL	-		

NOT USED IN THIS ASSEMBLY, USED IN SHAMPDD/SPOT PUMP ASSEMBLY ONLY.

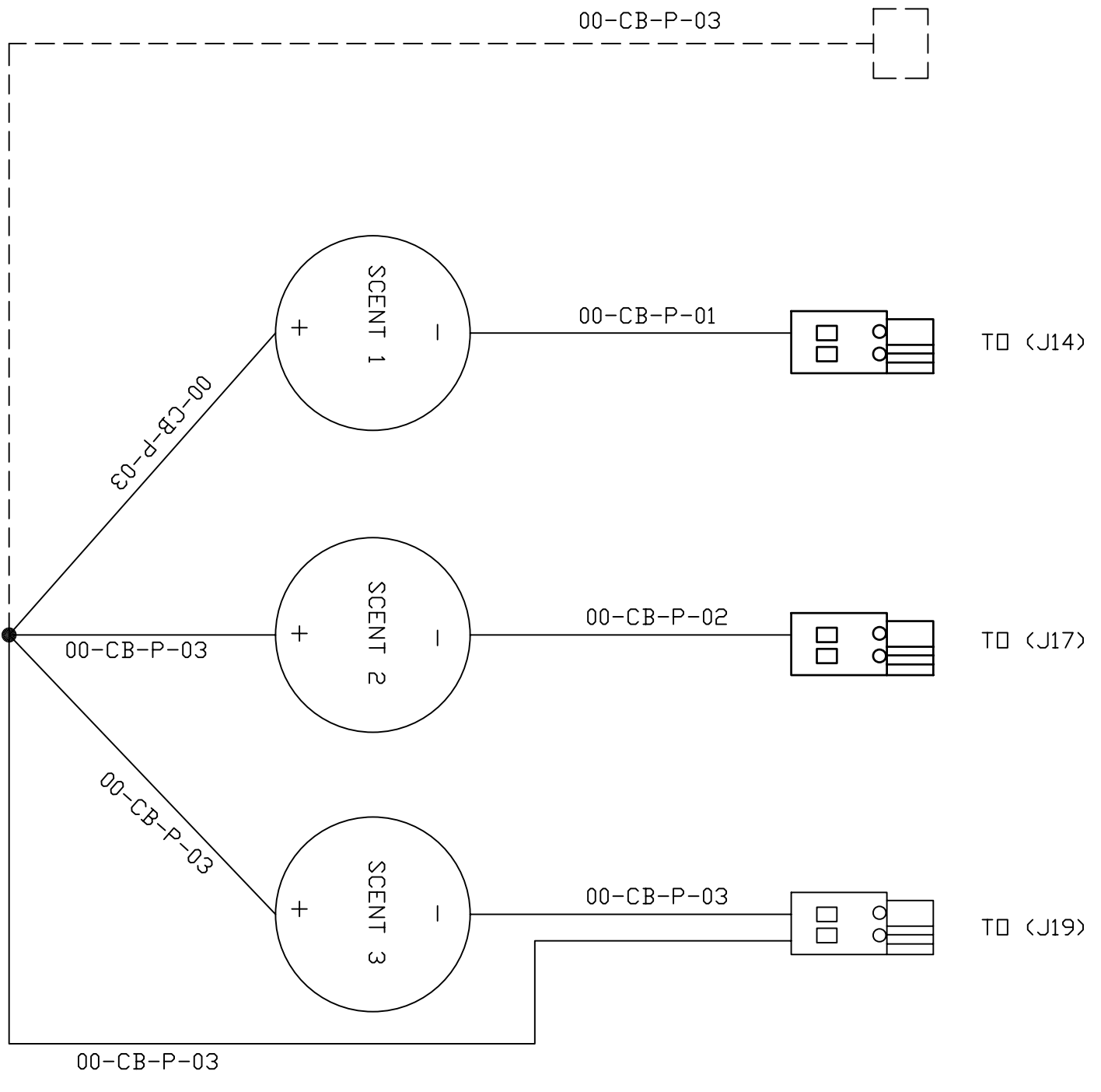

PUMP ASSEMBLY

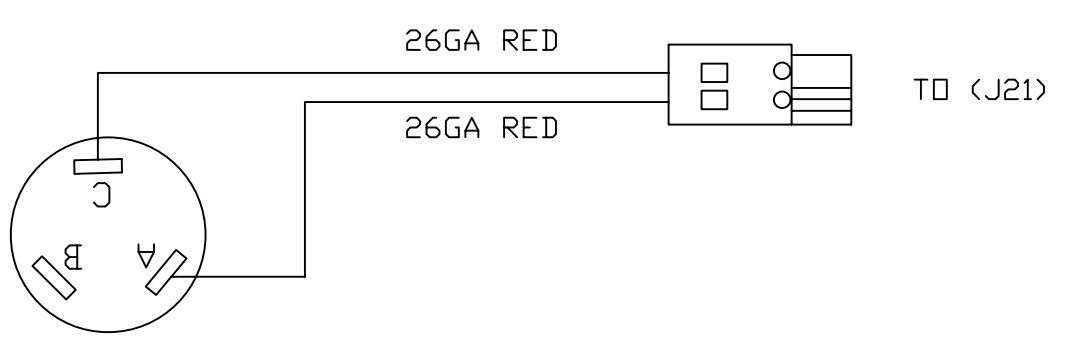

FRAGRANCE GUN ASSEMBLY

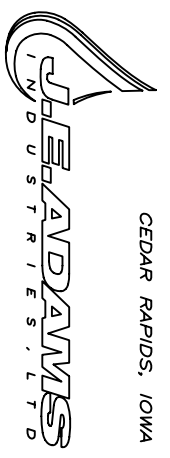
REV	NO.	DESCRIPTION	DATE	BY	<p>THIS DOCUMENT SHALL NOT BE REPRODUCED NOR SHALL THE INFORMATION THEREIN BE USED BY OR DISCLOSED TO OTHERS EXCEPT AS AUTHORIZED BY J.E. ADAMS INDUSTRIES</p>	<p>PART No. S29015_CB_PUMP</p>		<p>UNSPECIFIED TOLERANCES                  1 PL ±.030                  2 PL ±.010                  3 PL ±.003                  ANGLE ±1.0°</p>	TITLE			
WIRE DIAGRAM, 29015 PUMP ASSEMBLY									<p>DRAWN BY CK</p>	<p>DATE 3-16-09</p>	<p>SCALE -</p>	<p>REL. FOR PROD. -</p>

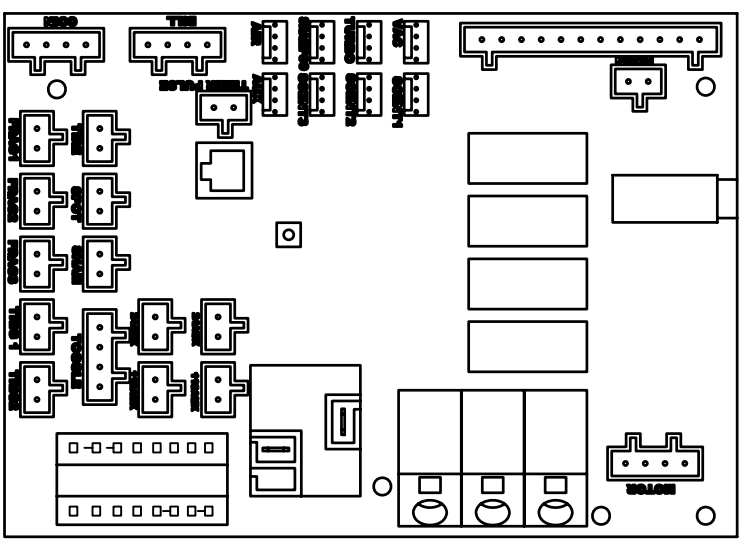
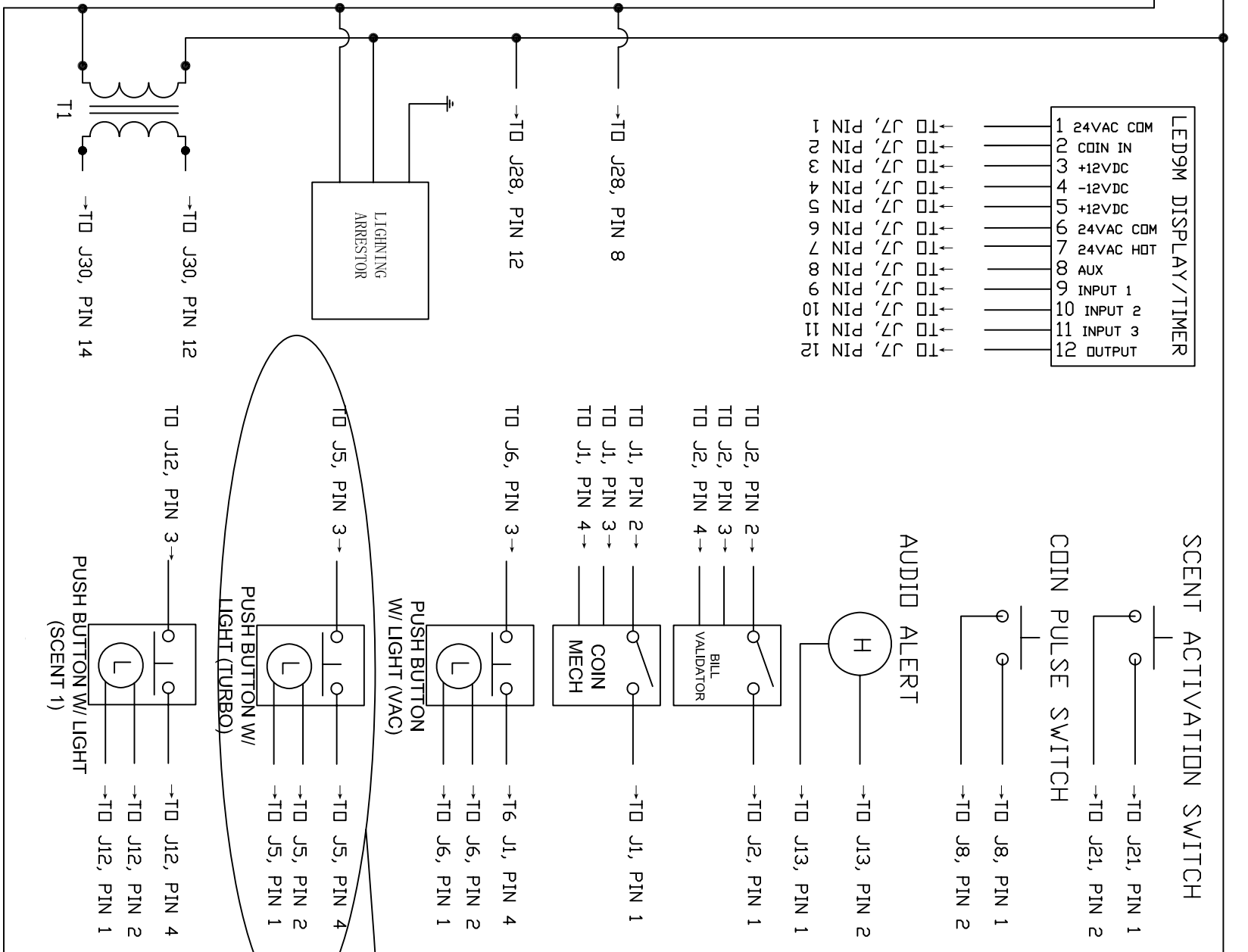
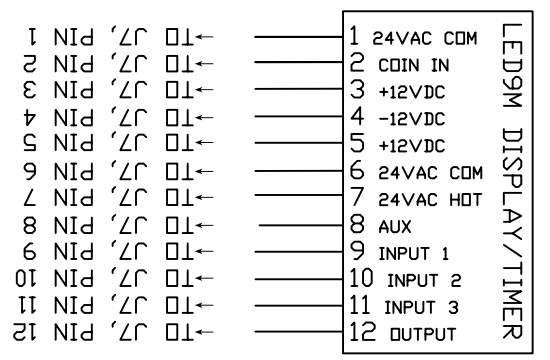
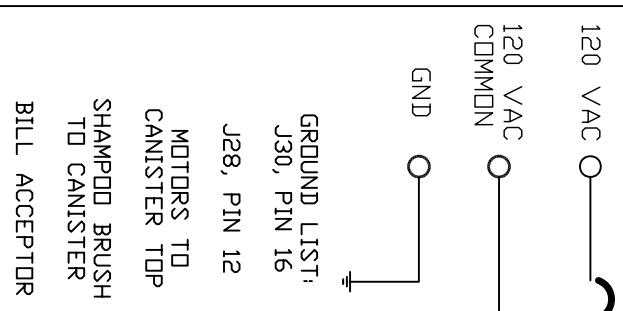

ALL (J) REFERENCES ARE TO THE CIRCUIT BOARD. SEE CB-5002 BOARD CONFIG (PDF) FOR CIRCUIT BOARD LAYOUT.

NOT USED ON MODELS 29000-2M THRU 29003-2M

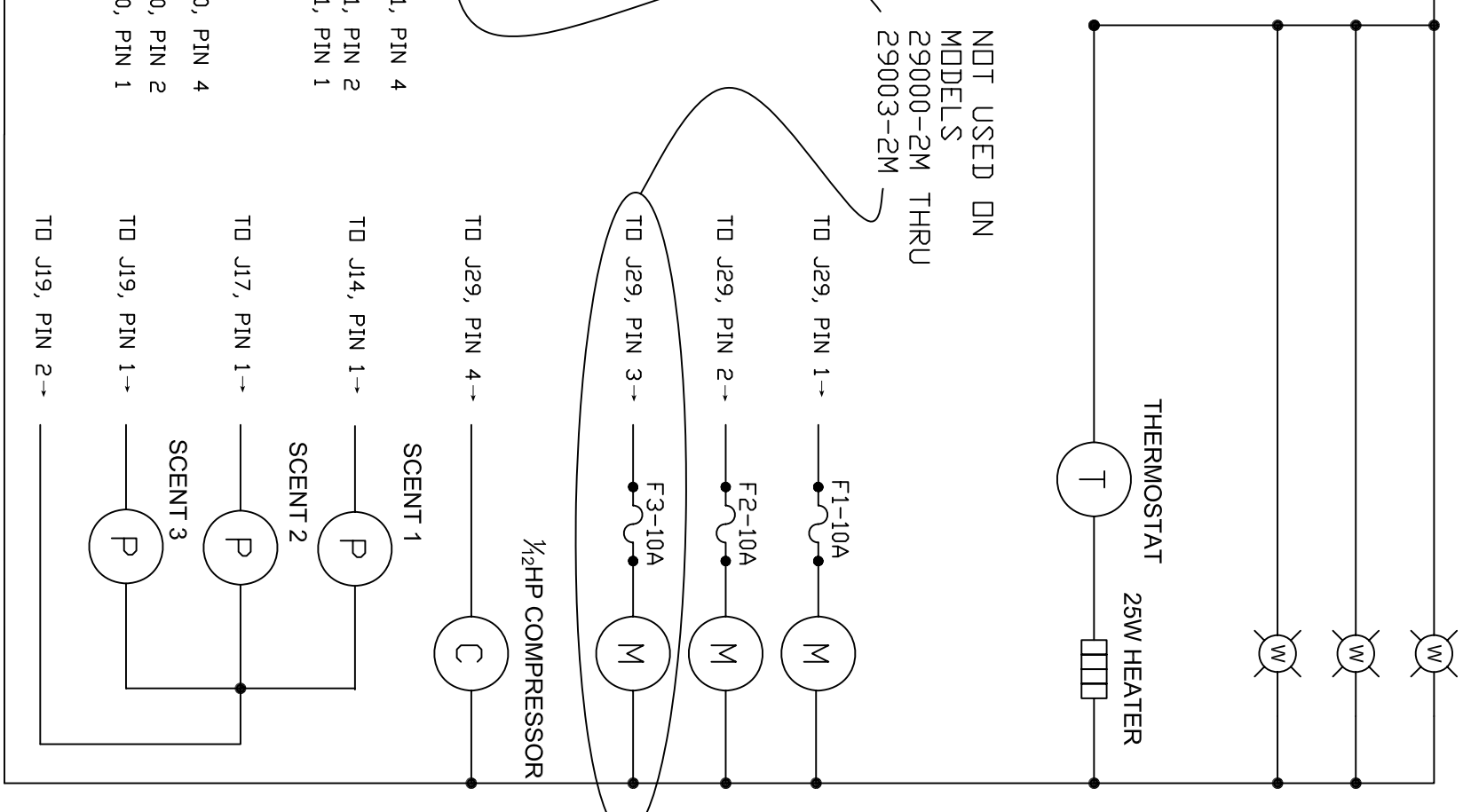

REV	NO.	DESCRIPTION	DATE	BY
A	5897	ADDED INFORMATION FOR 29015-2m THRU 29018-2M	5-20-10	CK

THIS DOCUMENT SHALL NOT BE REPRODUCED NOR SHALL THE INFORMATION THEREIN BE USED BY OR DISCLOSED TO OTHERS EXCEPT AS AUTHORIZED BY J.E. ADAMS INDUSTRIES

PART No. S29015-CB-ELEC

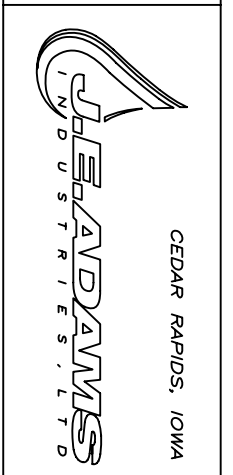

UNSPECIFIED TOLERANCES  
 FRACT. ±1/32  
 2 PL ±.020  
 3 PL ±.010  
 ANGLE ±1.0°

TITLE	29015 ELECTRICAL SCHEMATIC W/CB			
DRAWN BY	CK	DATE	3-09	SCALE
REL. FOR PROD.				
PART No.	S29015-CB-ELEC			REV. LEVEL