

User Manual



IP VANDAL DOME CAMERA



WARNING

TO REDUCE THE RISK OF FIRE OR ELECTRIC SHOCK, DO NOT EXPOSE THIS PRODUCT TO RAIN OR MISTURE.
DO NOT INSERT ANY METALLIC OBJECT THROUGH VENTILATION GRILLS.

CAUTION

	CAUTION RISK OF ELECTRIC SHOCK DO NOT OPEN	
CAUTION : TO REDUCE THE RISK OF ELECTRIC SHOCK. DO NOT REMOVE COVER (OR BACK). NO USER-SERVICEABLE PARTS INSIDE. REFER SERVICING TO QUALIFIED SERVICE PERSONNEL.		

COPYRIGHT

THE TRADEMARKS MENTIONED IN THE MANUAL ARE LEGALLY REGISTERED TO THEIR RESPECTIVE COMPANIES.

Content

I. PREFACE	4
II. PRODUCT SPECIFICATIONS.....	4
III. PRODUCT INSTALLATION.....	7
A. MONITOR SETTING	7
B. HARDWARE INSTALLATION	8
C. IP ASSIGNMENT	14
D. INSTALL ACTIVE X CONTROL:.....	18
IV. LIVE VIDEO	24
V. IP CAMERA CONFIGURATION	28
A. SYSTEM	29
B. NETWORK	34
C. A/V SETTING	46
D. EVENT LIST	54
VI. NETWORK CONFIGURATION.....	64
VIII. FACTORY DEFAULT	70
IX. UNIVERSAL PASSWORD	71
X. PACKAGE CONTENTS.....	74
XI. MICRO SD CARD COMPATIBILITY.....	75

I. Preface

This is a 5 megapixel IP vandal dome Camera with a web server built in. The user can view real-time video via IE browser. The IP Camera supports simultaneously H.264, Motion JPEG & MPEG4 video compression and dual streaming, which provides smooth and high video quality. The video can be stored in a micro SD card and playback remotely. With a user friendly interface, it is an easy-to-use IP Camera designed for security applications.

II. Product Specifications

- 5 Megapixel Vandal Dome
- Support Full HD 1080P Real Time
- External Vari-focal Lens Adjustment
- 3D+2D Digital Noise Reduction
- Support Digital Wide Dynamic Range
- Power over Ethernet Available
- IR LED Built in 15M Available
- Mechanism IR Cut Filter Available
- H.264/ M-JPEG/ MPEG4 Compression
- Micro SD Card Backup(Optional)
- Support 2-way Audio
- Video Output
- Support iPhone/iPad/Android
- SDK for Software Integration

Specifications

Hardware	
CPU	ARM 9 ,32 bit RISC
RAM	256MB
Flash	16MB
Image sensor	1/3.2" Megapixel CMOS sensor
Lens Type	Vari-focal Lens 3-9mm@F1.8
Sensitivity	B / W: 0.1 Lux (AGC ON)
Angle of View	27.31° ~ 75.22° (H) 19.09° ~ 54.16° (V)
ICR	Mechanism IR cut Filter (optional)
LED	Built-in 18 IR LED IR Distance 15M
I/O	1 DI / 1 DO
Video Output	Yes
Audio	G.711(64K) and G.726(32K,24K) audio compression Input : External Audio in Output: External Line out
Power over Ethernet	Yes, PoE Class 0 (IEEE802.3af)
Power	DC 12V Max: 4.8W(IR ON), 6.1W(IR OFF) PoE Max: 802.3af, 5.8W(IR ON), 7.2W(IR OFF)
Operating Temperature	-10°C ~ 45°C
Dimensions	φ137mm x 102mm (H)
Weight	890 g
Network	
Ethernet	10/ 100 Base-T
Network Protocol	IPv6, IPv4, HTTP, HTTPS, SNMP, QoS/DSCP, Access list, IEEE 802.1X, RTSP, TCP/ IP, UDP, SMTP, FTP, PPPoE, DHCP, DDNS, NTP, UPnP, 3GPP, SAMBA, Bonjour
System	
Video Resolution	2592x1944@15fps, 2048x1536@15fps, 1920x1080@30fps, 1280x720@30fps, 640x480@30fps, 320x240@30fps, 176x144@30fps

Video Adjust	Brightness, Contrast, Hue, Saturation, Sharpness, Shutter Speed adjustable, AGC, Sense-Up, D-WDR, Flip, Mirror, Noise reduction, Day&Night adjustable, White Balance
Triple Streaming	Yes
Image snapshot	Yes
Full screen monitoring	Yes
Privacy Mask	Yes, 3 different areas
Compression format	H.264/ M-JPEG/ MPEG4(3GPP Only)
Video bitrates adjust	CBR, VBR
Motion Detection	Yes, 3 different areas
Triggered action	Mail, FTP, Save to SD card, DO, SAMBA
Pre/ Post alarm	Yes, configurable
Security	Password protection, IP address filtering, HTTPS encrypted data transmission, 802.1X port-based authentication for network protection
Firmware upgrade	HTTP mode, can be upgraded remotely
Simultaneous connection	Up to 10
SD card management	
Recording trigger	Motion Detection, IP check, Network break down (wire only), Schedule, DI
Video format	AVI, JPEG
Video playback	Yes
Delete files	Yes
Client System requirement	
OS	Windows 7, 2000, XP, 2003, Microsoft IE 6.0 or above, Chrome, Safari, Firefox
Mobile Support	iOS 4.3 or above, Android 1.6 or above.
Hardware Suggested	Intel Dual Core 2.8G, RAM: 4GB

*SPECIFICATIONS ARE SUBJECT TO CHANGE WITHOUT NOTIFICATION.

III. Product Installation

A. Monitor Setting

- i. Right-Click on the desktop. Select “ Properties”



- ii. Change color quality to highest (32bit).

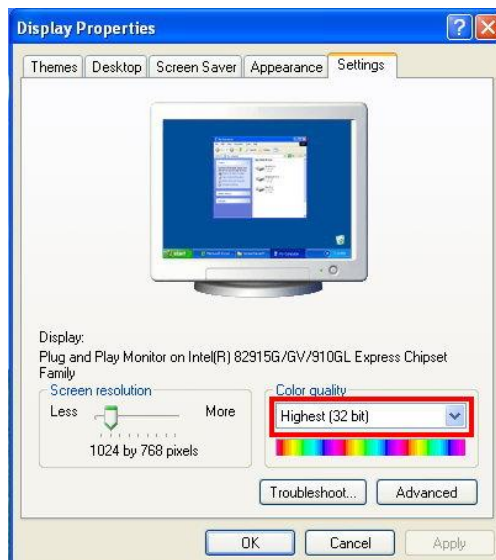

B. Hardware Installation

1. Connector Instruction

Open the cover to find the cable connector inside the Camera. Connect power adaptor first, then connect the IP Camera to PC or network, and set up the network configurations according to the network environment.

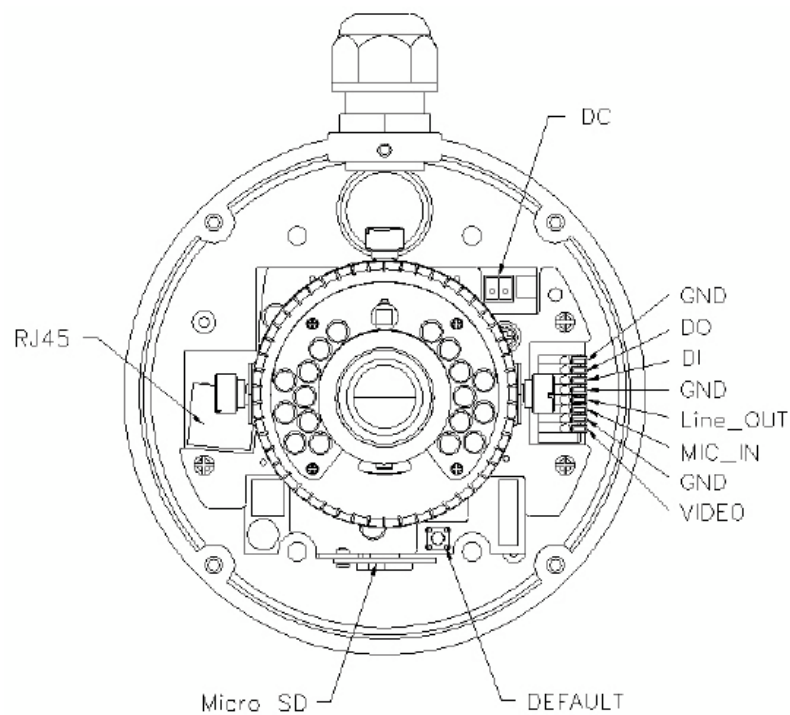

2. Vandal Dome Installation Tips

In order to ensure IP66 waterproof level, please install the vandal dome according with following instructions.

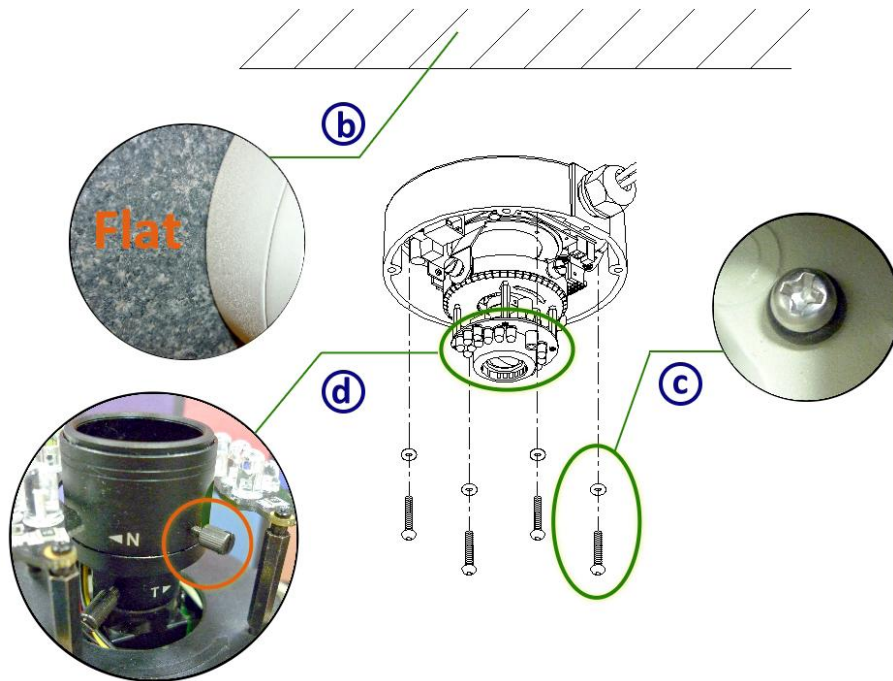

a. The Unused cable outlet hole must be closed, and the waterproof connector on the used hole must be locked closely.

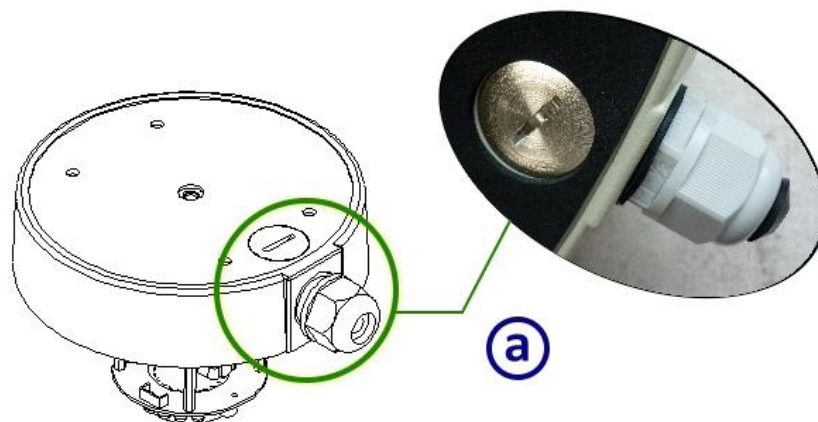

For keeping the IP, when using separate cables for Power and Internet, please use silicon in the cable gland, around the cables, just as shown in the following picture, indicated in yellow color.



- b. It is recommended that the bottom of housing be set smooth and closely flat with the surface.

- c. When you mount the camera housing on the ceiling or wall, please use the screws with the black rubber o-rings. Without the o-ring, the water may seep into the machine.

Make sure there are no cables around the screws, and slowly lock the four corners at the same time, applying equal force in every corner. **Do not totally lock one screw at a time**; otherwise the closing might not be equal in all four screws.



After locking the four screws the space between top-bottom sides will disappear.



- d. Turn and loose the control stick, shift right and left to adjust the vari-focal lens until the image becomes clear, then turn and tighten the stick to fix it.
- e. Use the 3-Axis bracket to adjust the camera to appropriate angle.

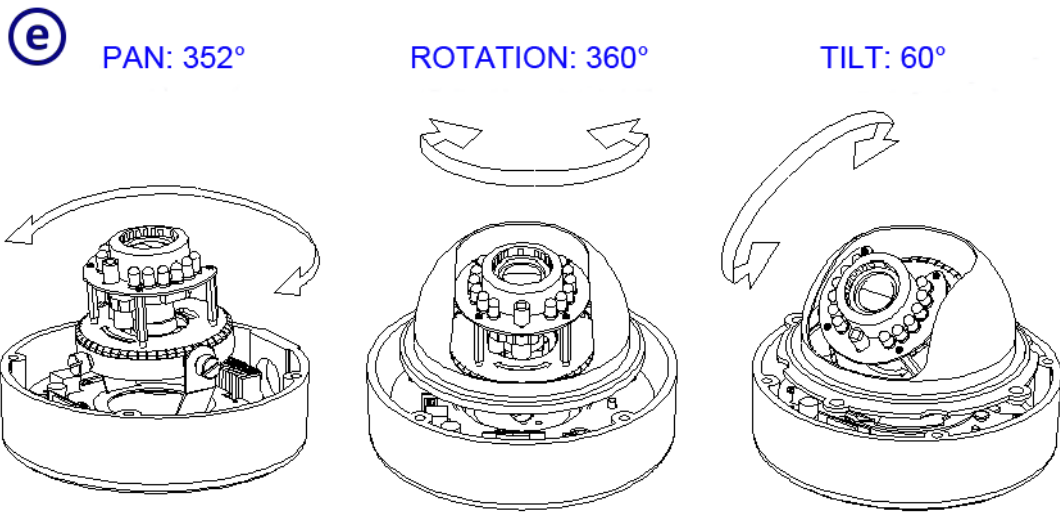

f. Before you close the dome cover, make sure that the black rubber band sticks to the inside of the cover completely. Crook or uneven rubber band may cause the waterproof defective.

g. Lock tightly the screws on the dome cover to ensure there's no gap between the lid and base.

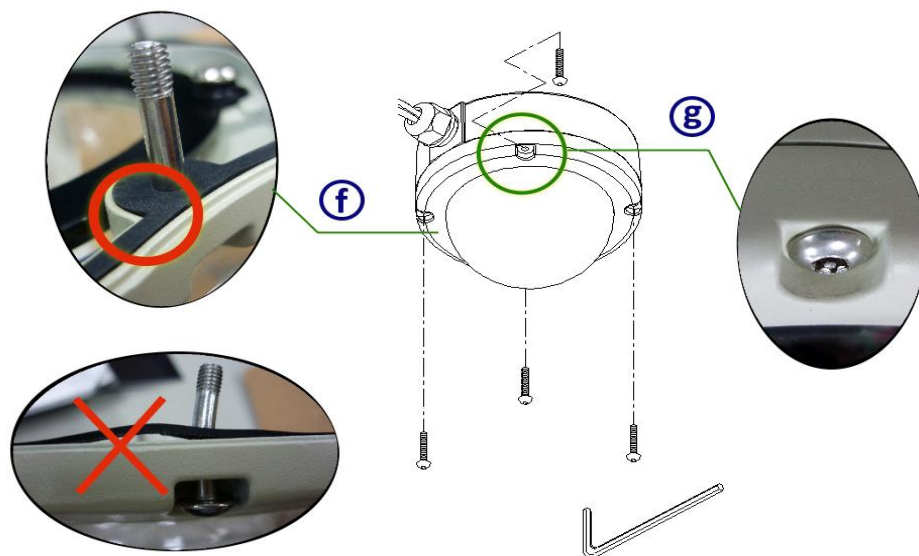

3. PoE (Power Over Ethernet)(Optional) **802.3af, 15.4W PoE Switch is recommended**

Power over Ethernet (PoE) is a technology that integrates power into a standard LAN infrastructure. It enables power to be provided to a network device, such as an IP phone or a network camera, using the same cable as that used for network connection. It eliminates the need for power outlets at the camera locations and enables easier application of uninterruptible power supplies (UPS) to ensure 24 hours a day, 7 days a week operation.

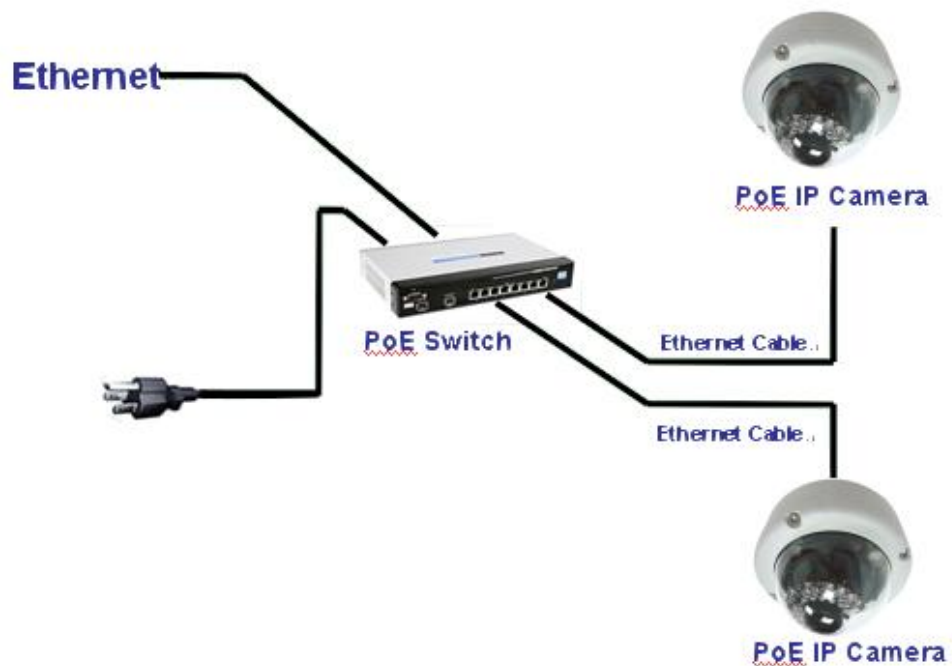

C. IP Assignment

- i. Use the software, "IP Installer" to assign the IP address of IP CAMERA. The software is in the attached software CD.
- ii. IP installer supports two languages
 - a. IPInstallerCht.exe : Chinese version
 - b. IPInstallerEng.exe : English version
- iii. There are 3 kinds of IP configuration.
 - a. Fixed IP (Public IP or Virtual IP)
 - b. DHCP (Dynamic IP)
 - c. Dial-up (PPPoE)
- iv. Execute IP Installer
- v. For Windows XP SP2 user, it may popup the following message box. Please click "Unblock".



vi. IP Installer configuration:

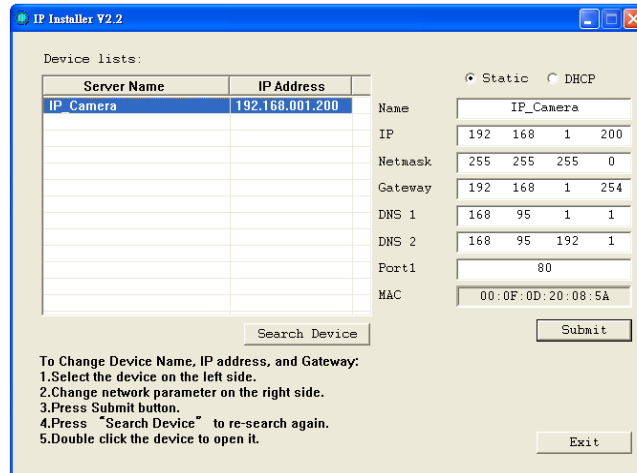

- vii. IP Installer will search all IP Cameras connected on LAN. The user can click “Search Device” to search again.
- viii. Click one of the IP Camera listed on the left side. The network configuration of this IP camera will show on the right side. You may change the “name” of the IP Camera to your preference (e.g.: Office, warehouse). Change the parameter and click “Submit” then click “OK”. It will apply the change and reboot the Device.



- ix. Please make sure the subnet of PC IP address and IP CAM IP address are the same.

The same Subnet:

IP CAM IP address: 192.168.1.200

PC IP address: 192.168.1.100

Different Subnets:

IP CAM IP address: 192.168.2.200

PC IP address: 192.168.1.100

To Change the PC IP address:

Control Panel → Network Connections → Local Area Connection Properties → Internet Protocol (TCP/IP) → Properties

Make sure your IP Camera and PC have the same Subnet. If not, change the IP Camera subnet or PC IP subnet accordingly.

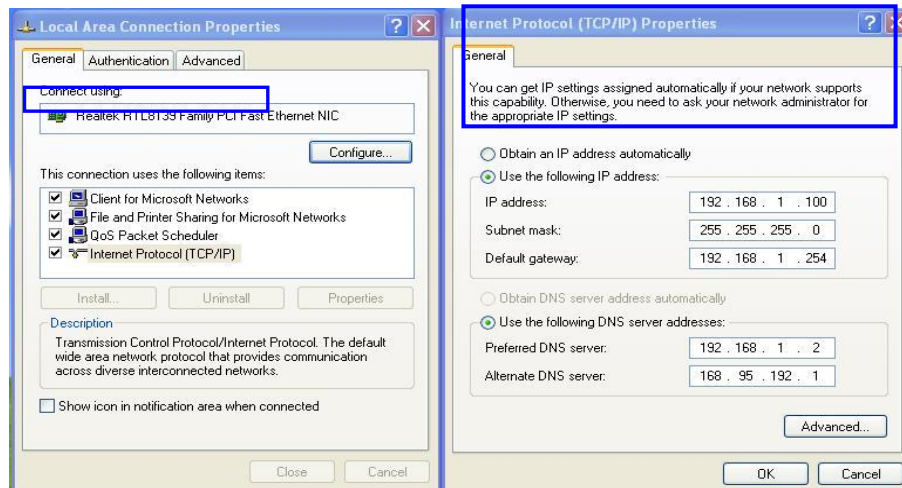

- x. A quick way to access remote monitoring is to left-click the mouse twice on a selected IP Camera listed on “Device list” of the IP Installer. An IE browser will be opened.

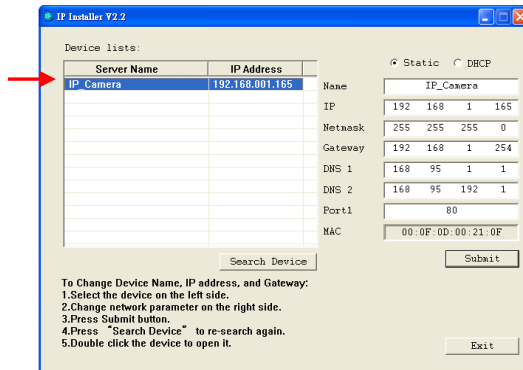

- xi. Then, please key-in the default “user name: admin” and “password: admin”.



D. Install ActiveX control:

1. To users of IE 6.0 above:

In the first time you access the camera via IE, it will ask you to install the ActiveX component. If the installation failed, please check the security setting for the IE browser.

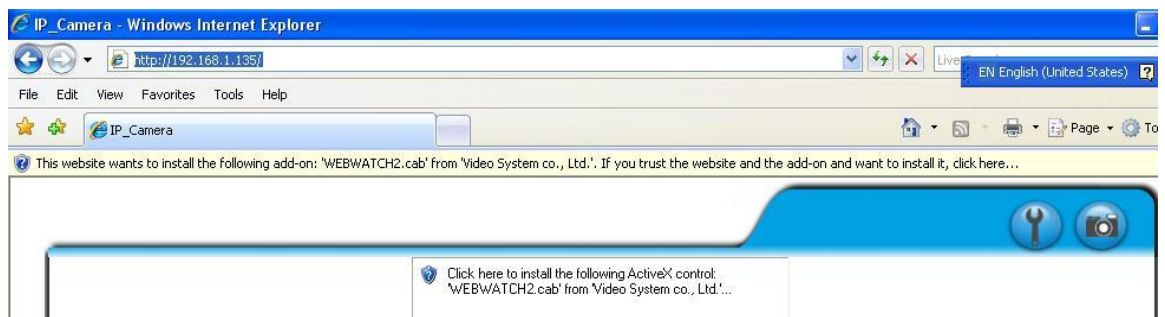

1. If the installation failed, please check the security setting for the IE browser.
 - i. IE → Tools → Internet Options... → Security Tab → Custom Level... → Security Settings → Download unsigned ActiveX controls → Select "Enable" or Prompt.
 - ii. IE → Tools → Internet Options... → Security Tab → Custom Level... → Initialize and script ActiveX controls not marked as safe → Select "Enable" or Prompt.

1



2

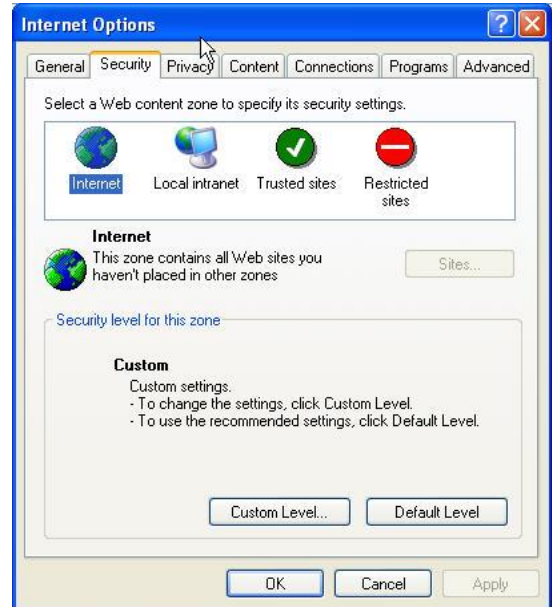

3

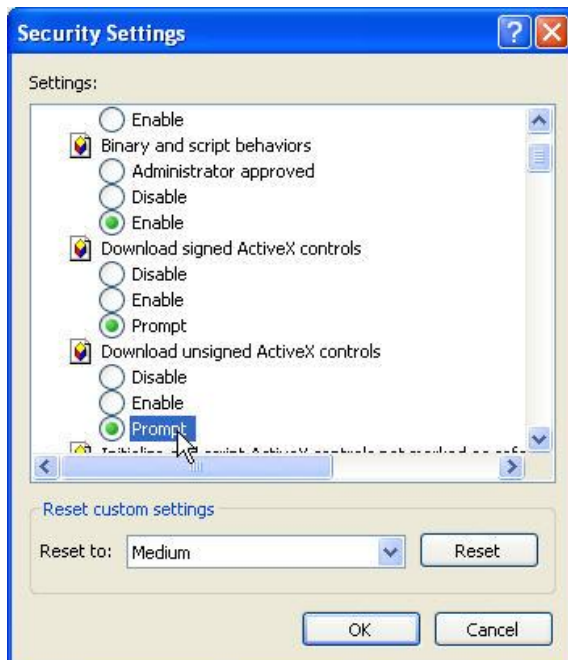

4



When pops up the following dialogue box, click “Yes”.

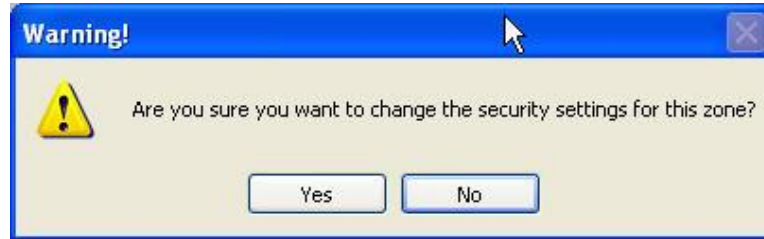

2. You can choose another way:

Go to: IE→Tools → Internet Options... → Security Tab → Trusted sites → Add the IP address and click "OK".

In the site list you can key one single IP address or a LAN address. For example, if you add "192.168.21.*", all the IP address under .21 LAN will be regarded as trusted sites.

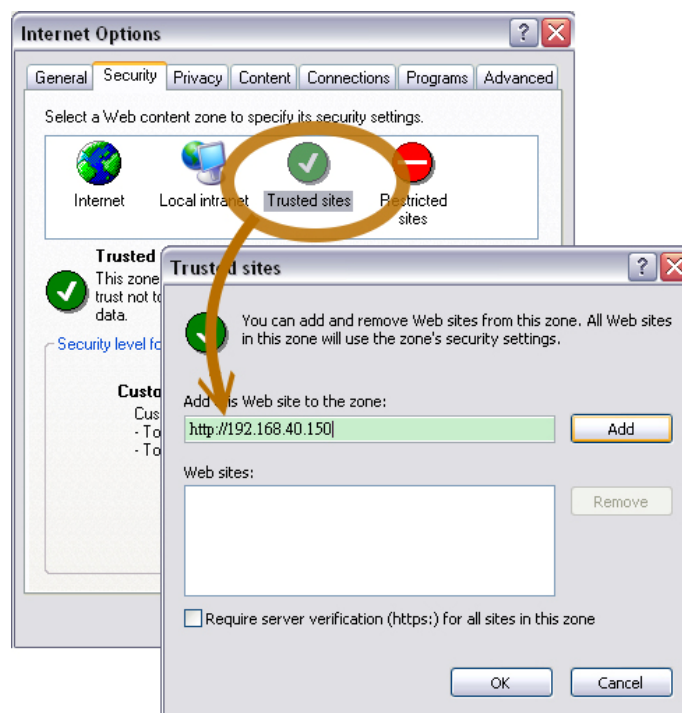

2. Use Non-IE Web Browser

If you use Firefox or Google chrome to access the IP camera but fail to watch the live video, please follow the steps to install necessary tools:
(The following pictures are based on chrome.)

a. You may see the prompt message as the picture below. First, click the link:

"Firstly, please install Microsoft Visual C++ 2010 Redistributable Package (x86)."

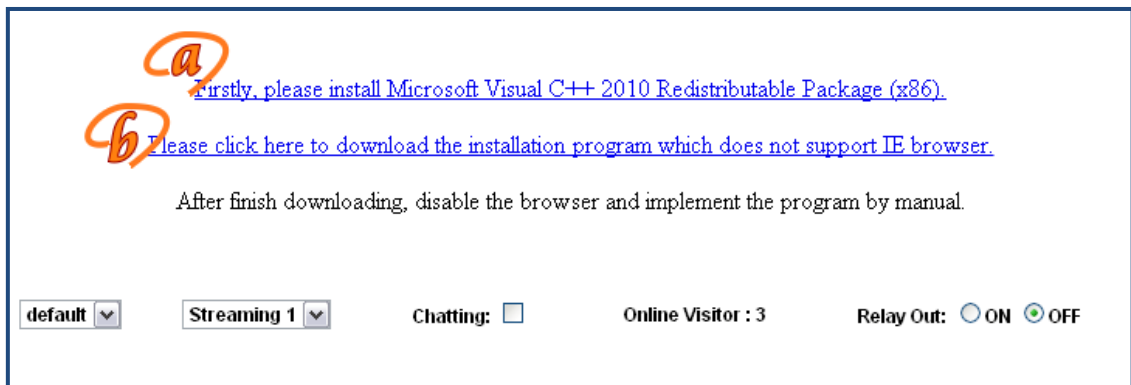

(i) The link conducts you to the Microsoft official site where you can download the tools. Please select the language and click "download".

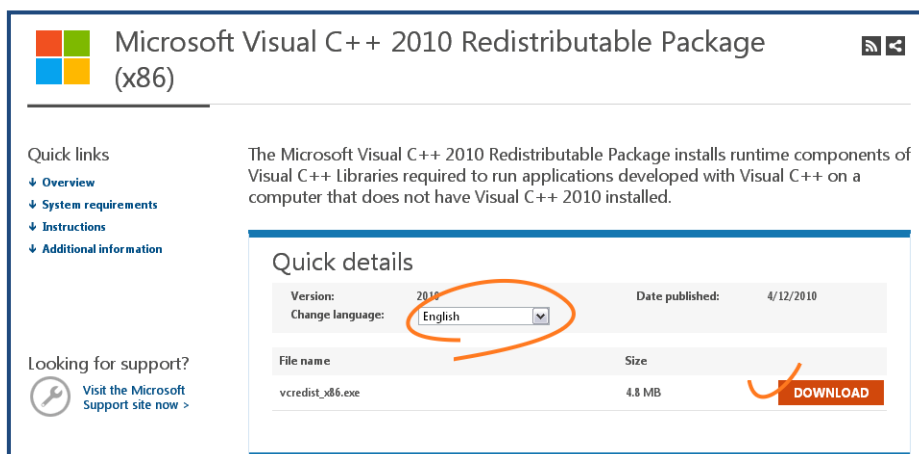

(ii) In the pop-up window, please tick the first and the third file as the picture below. Click "Next" to download both "Microsoft .NET Framework 4 Client Profile (Web Installer)" and "Microsoft Visual C++ 2010 Redistributable Package (x64)".

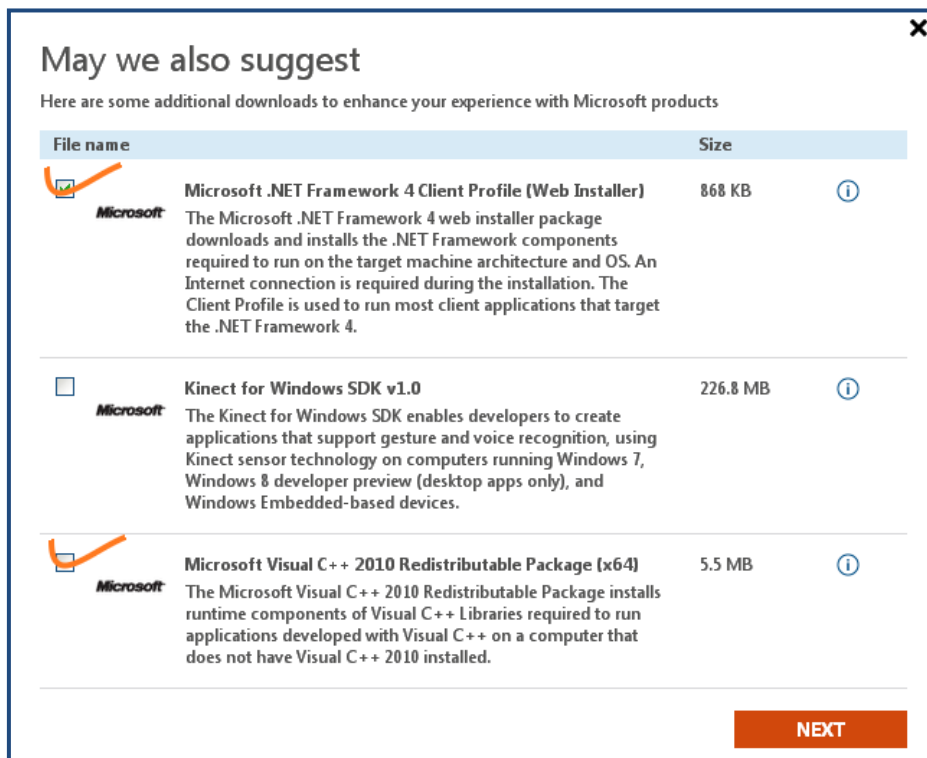

(iii) After finishing downloading, execute the two files respectively to install them. The windows may ask you to reboot the PC when the installation is finished.



b. Then, click the second link "Please click here to download the installation program which does not support IE browser." to download Setup ActiveX.

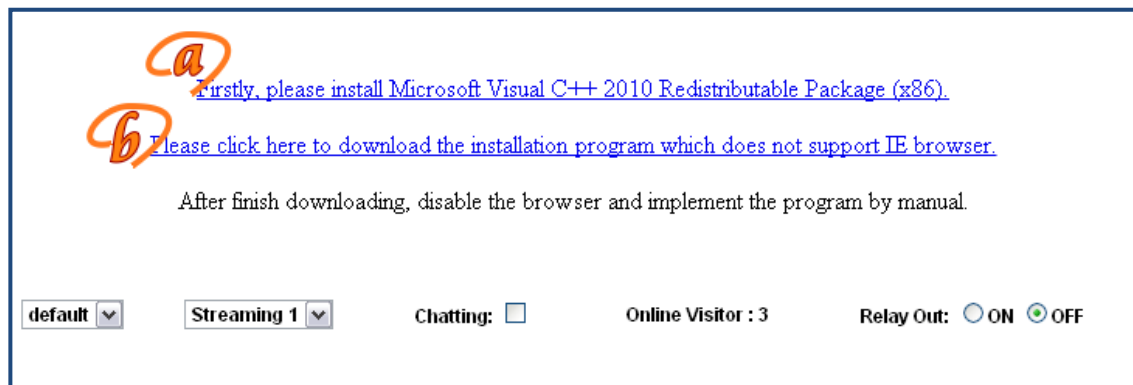

After finishing the downloading, execute the files to install ActiveX. Then restart the browser.

c. If you execute the steps above but still cannot see the live video normally, please try the solution:

(i) Search for the file "np_hoem_x.dll" in your system disk. For Windows XP users, please go to "Start" → "Search" → Search for "All files and folders" and key-in "np_hoem_x.dll". For Windows 7 users, please use the search bar on the top-right of the Windows Explorer.

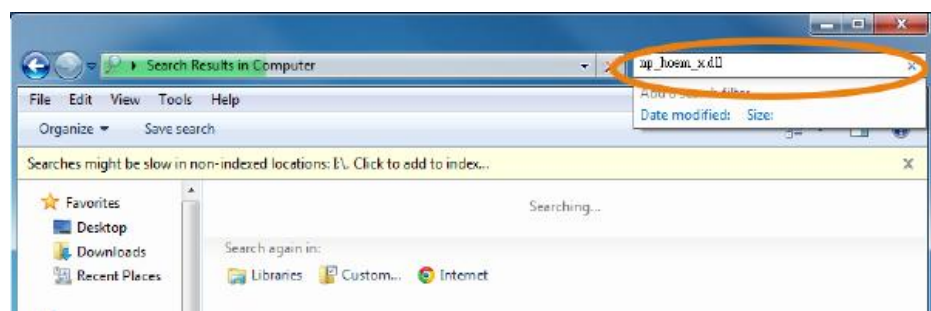

(ii) Delete all the files named "np_hoem_x.dll". They're the ActiveX control tools installed in your computer, but the old version of ActiveX might not be compatible with the new version of browser. Therefore, they need to be deleted in order to install the latest ActiveX control.

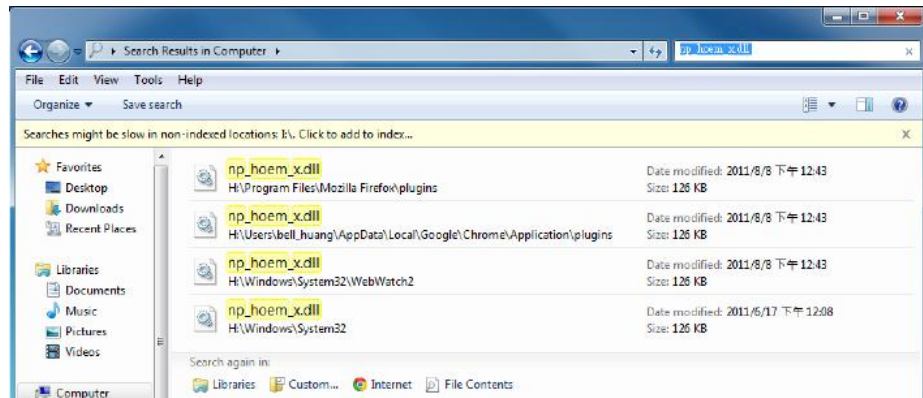

(iii) Start your web browser, and repeat the step 2-b: "Download the installation program which does not support IE browser" to download and install ActiveX.

a [Firstly, please install Microsoft Visual C++ 2010 Redistributable Package \(x86\).](#)

b [Please click here to download the installation program which does not support IE browser.](#)

After finish downloading, disable the browser and implement the program by manual.

default | Streaming 1 | Chatting: | Online Visitor : 3 | Relay Out: ON OFF

IV. Live Video

Start an IE browser, type the IP address of the IP camera in the address field. It will show the following dialogue box. Key-in the user name and password. The default user name and password are “**admin**” and “**admin**”.



When the IP Camera is connected successfully, it shows the following program interface:

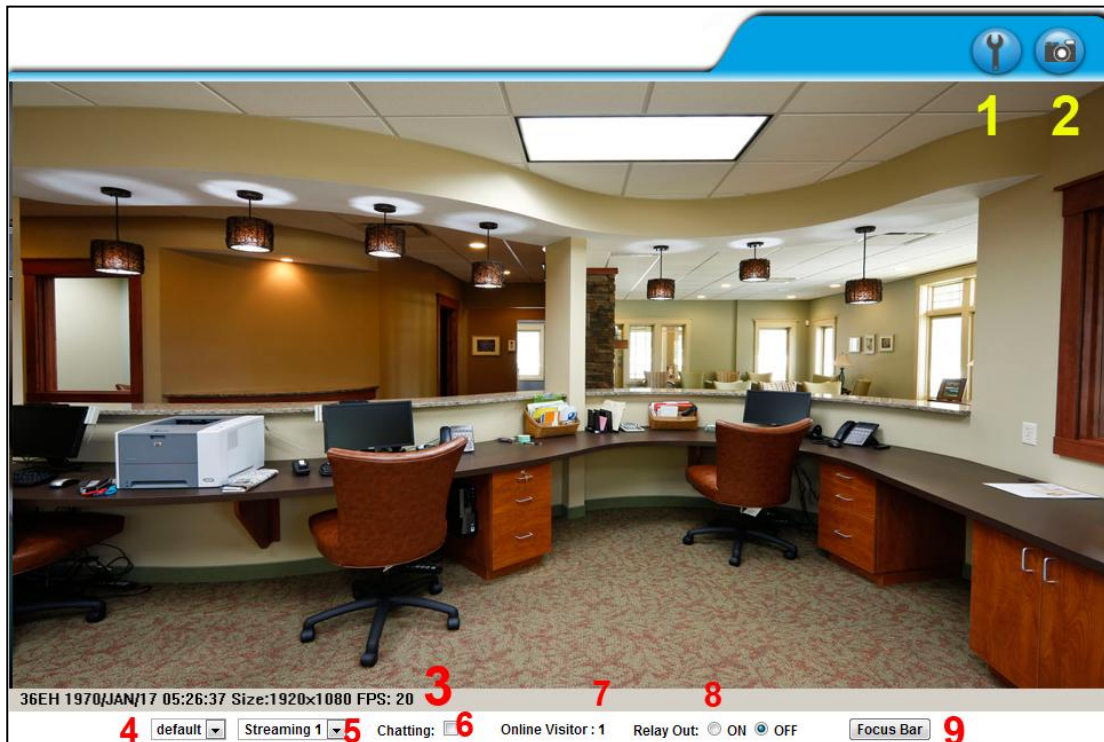

Double-click the video to switch to full screen view. Press "Esc" or double-click the video again back to normal mode.

1. Get into administration page
2. Video Snapshot
3. Show system time, video resolution, and video refreshing rate
4. Adjust image, 1/2x, 1x, 2x
5. Select video streaming source (If in "Video Setting" the streaming 2 setting is closed, this option will not appear here.)
6. IP Camera supports 2-way audio. Click the "Chatting" check box for using a microphone connected to the PC and talk to the Camera side.
7. Show how many people are connected to this IP camera.
8. Tick the Relay out "ON" box to trigger the relay output for testing. Tick "Off" to stop triggering.
9. Focus Bar: a focus bar will appear on the top-left corner of live view.
The bar is for users' reference when adjusting the lens focus. If the lens focus is adjusted to clear, the bar will be filled.



When remote accessing an IPCam by web browser, the focus bar will be hidden after 3 minutes. When connecting the video out connector to a monitor, the bar will keep showing on the view.

Double-click the video; it will change to full screen mode. Press “Esc” or double-click the video again, it will change back to normal mode.

Right-Click the mouse on the video, it will show a pop-up menu.

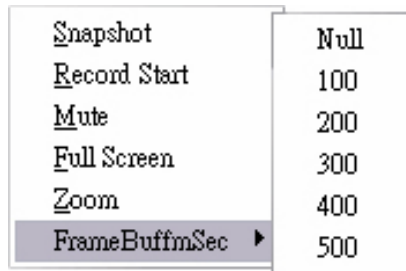

1. Snapshot : Save a JPEG picture
2. Record Start: Record video in the local PC. It will ask you where to save the video. To stop recording, right-click the mouse again. Select “Record Stop”. The video format is AVI. Use Microsoft Media Player to play the recorded file.
3. Mute: Turn off the audio. Click again to turn it on.
4. Full Screen: Full-screen mode.
5. ZOOM: Enable zoom-in and zoom-out functions. Select “Enable digital zoom” option first on the pop-up dialogue box and then drag and drop the bar to adjust the zoom factors.

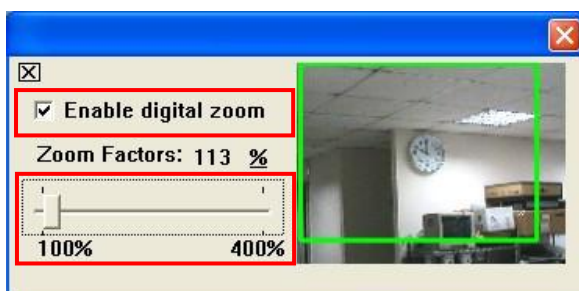

6. Frame Buffm Sec: Build a buffm to accumulate several video frames and play them at regular intervals. This function can keep the video smoothly when the

Network speed is slow. If you select “100”, the interval between every frame is fixed to 100 mSec. The slower the Network is, the bigger value should be selected. The default value is null.

V. IP Camera Configuration



Click



to go back to the live

video page.

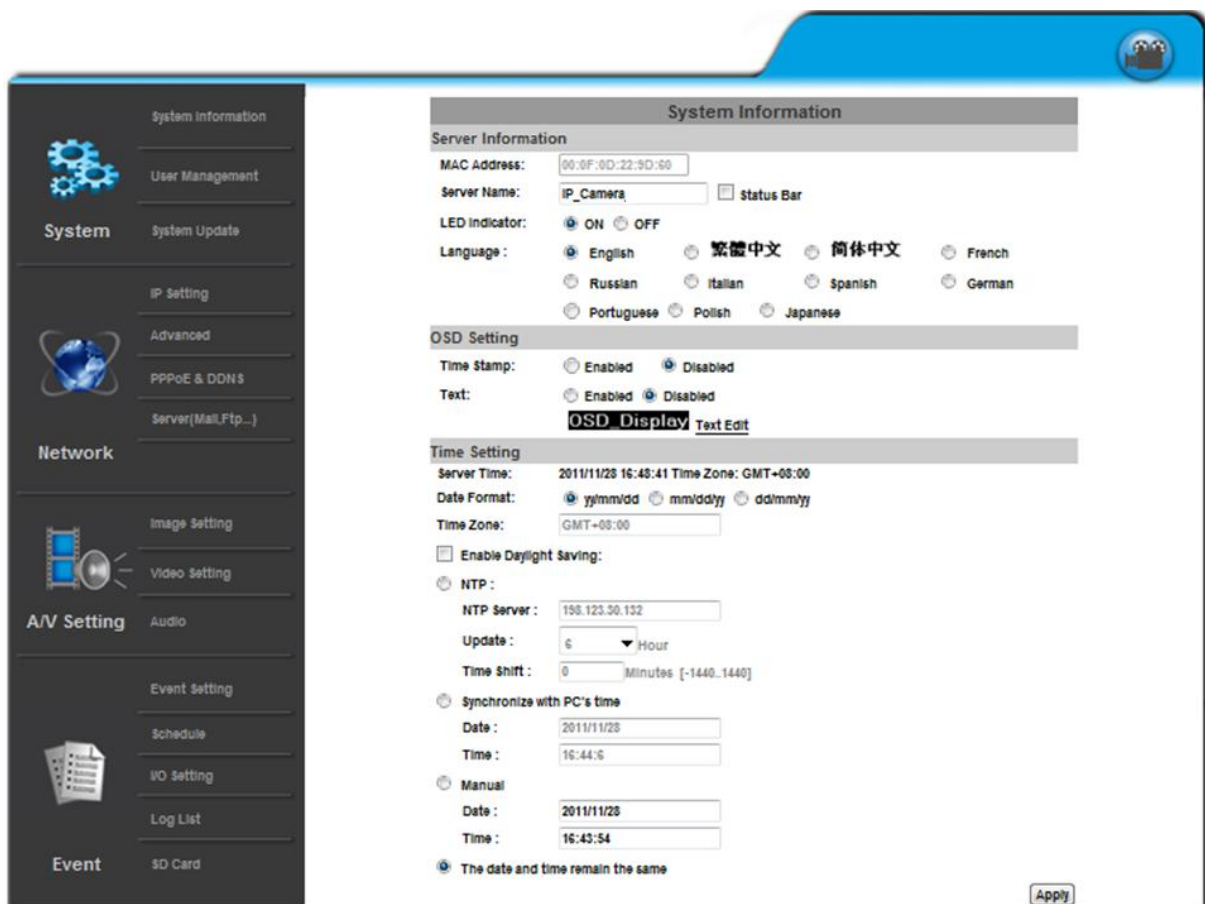

The screenshot shows the IP Camera configuration web interface. On the left is a dark sidebar menu with categories: System (containing System Information, User Management, System Update), Network (containing IP Setting, Advanced, PPPoE & DDNS, Server(Mail,Ftp...)), A/V Setting (containing Image Setting, Video Setting, Audio), and Event (containing Event Setting, Schedule, IO Setting, Log List, SD Card). The main content area is titled 'System Information' and contains several sections: 'Server Information' with fields for MAC Address (00:0F:9D:22:3D:50), Server Name (IP_Camera), LED Indicator (ON/OFF), and Language (English, 繁體中文, 简体中文, French, Russian, Italian, Spanish, German, Portuguese, Polish, Japanese); 'OSD Setting' with Time Stamp (Enabled/Disabled) and Text (Enabled/Disabled) options, and a link for 'OSD Display' Text Edit; 'Time Setting' with Server Time (2011/11/28 16:48:41), Date Format (yy/mm/dd, mm/dd/yy, dd/mm/yy), Time Zone (GMT+08:00), and NTP settings (NTP Server: 198.123.30.132, Update: 6 Hour, Time Shift: 0 Minutes); and 'Synchronize with PC's time' with Date and Time fields for both Manual and NTP modes. An 'Apply' button is at the bottom right.

A. System

i. System Information

a. **Server Information:** Set up the camera name, select language, and set up the camera time.

1. **Server Name:** This is the Camera name. This name will be shown on the IP Installer.

2. **Select language:** English, Traditional Chinese, and Simplified Chinese can be selected. When it changes, it will show the following dialogue box to confirm the language changing.



b. **OSD Settings:** Select a position where the date & time stamp / text are shown on the screen.



Click 'Text Edit' to adjust the OSD text contents. Alpha means background transparency of the text. If you select 100%, the text stamp will be directly displayed on the live screen. If you select 0%, the text stamp will be displayed with a black background.

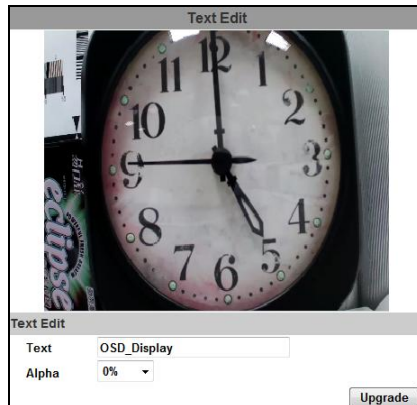

- c. Server time setting: Select options to set up time - “NTP”, “Synchronize with PC’s time”, “Manual”, “The date and time remain the same”.

Time Setting

Server Time: 2011/11/28 18:48:45 Time Zone: GMT+08:00

Date Format: yy/mm/dd mm/dd/yy dd/mm/yy

Time Zone: GMT+08:00

Enable Daylight Saving:

	Month	Week	Day of Week	Time
DST Start:	Mar	2nd	Sun	12 am
DST End:	Nov	1st	Sat	12 am

NTP :

NTP Server : 198.123.30.132

Update : 6 Hour

Time Shift : 0 Minutes [-1440..1440]

Synchronize with PC's time

Date : 2011/11/28

Time : 18:44:11

Manual

Date : 2011/11/28

Time : 18:43:47

The date and time remain the same

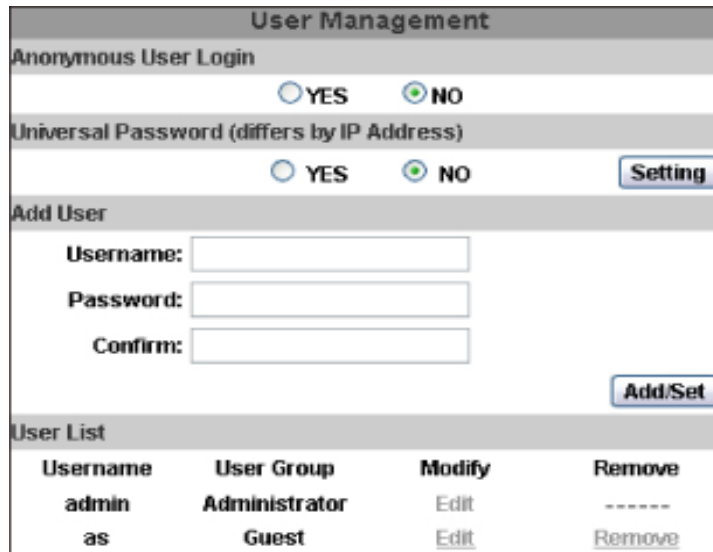

The image shows a web-based configuration interface for user management. It is divided into several sections:

- User Management**: The main title of the page.
- Anonymous User Login**: A section with two radio buttons: YES and NO.
- Universal Password (differs by IP Address)**: A section with two radio buttons: YES and NO, and a **Setting** button.
- Add User**: A section with three input fields: **Username:**, **Password:**, and **Confirm:**, followed by an **Add/Set** button.
- User List**: A table showing the current user configuration.

Username	User Group	Modify	Remove
admin	Administrator	Edit	-----
as	Guest	Edit	Remove

ii · User Management

The IP Camera supports three different users: administrator, general user and anonymous user.

a. Anonymous User Login:

Select “Yes” for allowing everybody to watch live video without needing a username and password. However, if you try to enter the configuration page the camera will ask to key-in username and password.

Select “No” for requiring a username and login to access the camera.

b. Universal Password:

Select “Yes” for allowing login to this IP Cam by universal password.

Select “No” for disabling universal password.

c. Add user:

Type the user name and password, then click “Add/Set”. The guest user can only browse live video page and is not allowed to enter the configuration page.

d. Click “edit” or “delete” in the user list to modify them. The system will ask you to key-in the password in the pop-up window before you edit the user information.

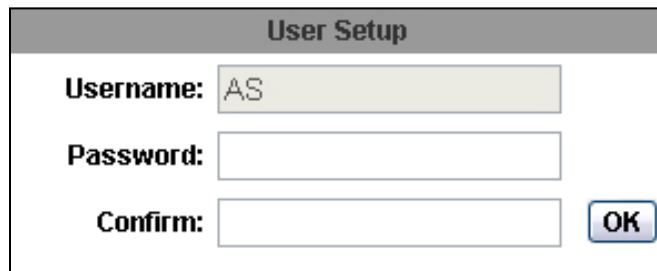

The image shows a 'User Setup' dialog box with a title bar. It contains three input fields: 'Username:' with the text 'AS', 'Password:', and 'Confirm:'. To the right of the 'Confirm:' field is an 'OK' button.

iii 、 System update :

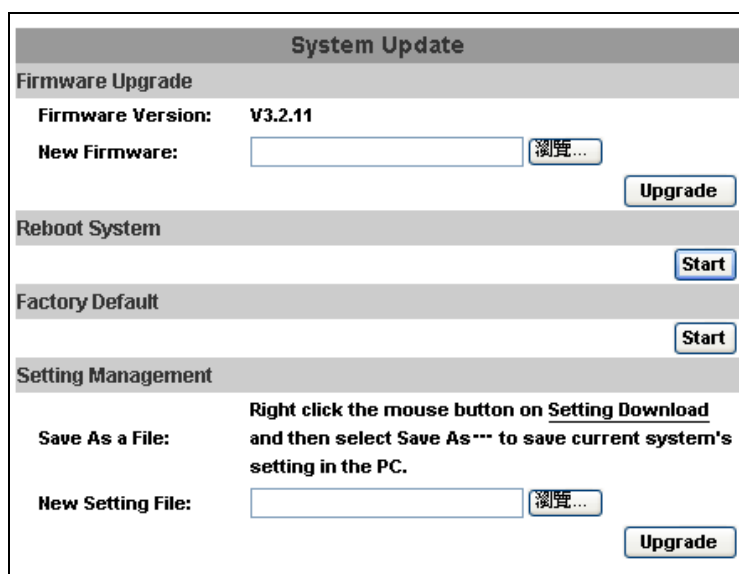

The image shows a 'System Update' dialog box with a title bar. It is divided into several sections: 'Firmware Upgrade' with 'Firmware Version: V3.2.11' and a 'New Firmware:' field with a '瀏覽...' button and an 'Upgrade' button; 'Reboot System' with a 'Start' button; 'Factory Default' with a 'Start' button; and 'Setting Management' with a 'Save As a File:' field, a 'New Setting File:' field with a '瀏覽...' button, and an 'Upgrade' button. A note reads: 'Right click the mouse button on Setting Download and then select Save As... to save current system's setting in the PC.'

- a. To update the firmware online, click “Browse...” to select the firmware. Then click “Upgrade” to proceed.
- b. Reboot system: re-start the IP camera
- c. Factory default: delete all the settings in this IP camera.
- d. Setting Management: The user may download the current settings to PC, or upgrade from previous saved settings.

1. Settings download:

Right-click the mouse button on Setting Download → Select “Save AS...” to save current IP Camera settings in PC → Select saving directory → Save

2. Upgrade from previous settings

Browse → search previous settings → open → upgrade → Settings update confirm → click [index.html](#) for returning to main page

B. Network

i. IP Settings

The IP Camera supports DHCP and static IP.

IP Setting	
IP Assignment	
<input type="radio"/> DHCP	
<input checked="" type="radio"/> Static	
IP Address:	<input type="text" value="192.168.1.200"/>
Subnet Mask:	<input type="text" value="255.255.255.0"/>
Gateway:	<input type="text" value="192.168.1.254"/>
DNS 0:	<input type="text" value="168.95.1.1"/>
DNS 1:	<input type="text" value="168.95.192.1"/>
Port Assignment	
Web Page Port:	<input type="text" value="80"/>
HTTPS Port:	<input type="text" value="443"/> <small>HTTPS Setting</small>
UPnP	
UPnP:	<input checked="" type="radio"/> Enabled <input type="radio"/> Disabled
UPnP Port Forwarding:	<input type="radio"/> Enabled <input checked="" type="radio"/> Disabled
External Web Port:	<input type="text" value="80"/>
External https Port:	<input type="text" value="443"/>
External RTSP Port:	<input type="text" value="554"/>

- a. DHCP: The IP Camera will get all the network parameters automatically.
- b. Static IP: Type-in the IP address subnet mask, gateway, and DNS manually.
- c. Port Assignment: The user may need to assign different port to avoid conflicts when setting up the IP.

1. Web Page Port: setup web page connecting port and video

transmitting port (Default: 80)

2. HTTPs Port: setup the https port(Default: 443)

d. UPnP

The IP camera supports UPnP, if this service is enabled on your computer, the camera will automatically be detected and a new icon will be added to “My Network Places.”

UPnP Port Forwarding : Enable UPnP Port Forwarding for accessing the IP Camera from the Internet; this option allows the IP Cam to open ports on the router automatically so that video streams can be sent out from a LAN. There are three external ports for being set: Web Port, Http Port and RTSP port. To utilize of this feature, make sure that your router supports UPnP and is activated.

Note: *UPnP must be enabled on your computer.*

Please follow the procedure to activate UPnP:

1. Open the **Control Panel** from the **Start Menu**
2. Select **Add/Remove Programs**
3. Select **Add/Remove Windows Components** and open **Networking Services** section
4. Click **Details** and select **UPnP** to setup the service
5. The IP device icon will be added to “My Network Places”

6. User may double click the IP device icon to access IE browser

e. RTSP setting

1. RTSP Server: enable or disable
2. RTSP Port: setup port for RTSP transmitting (Default: 554)
3. RTP Start and End Port: in RTSP mode, you may use TCP and UDP for connecting. TCP connection uses RTSP Port (554). UDP connection uses RTP Start and End Port.

ii · Advanced:

- a. Https (Hypertext Transfer Protocol Secure): Https can help to protect streaming data transmission on a higher security level.

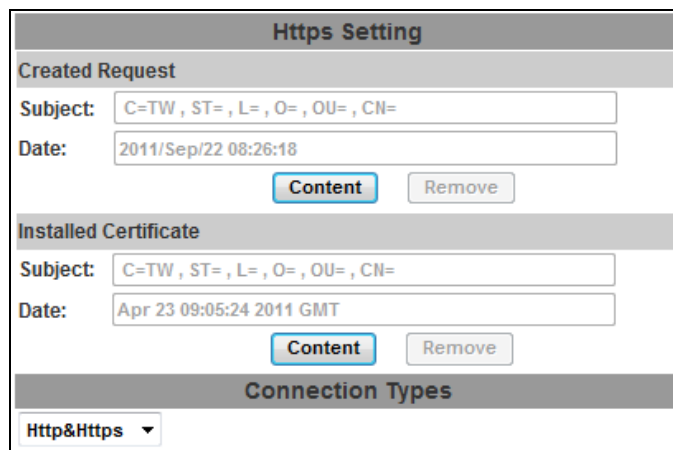

The screenshot shows the 'Https Setting' configuration window. It is divided into three main sections: 'Created Request', 'Installed Certificate', and 'Connection Types'.
1. 'Created Request' section: Contains a 'Subject' field with the value 'C=TW, ST=, L=, O=, OU=, CN=' and a 'Date' field with the value '2011/Sep/22 08:26:18'. Below these fields are two buttons: 'Content' and 'Remove'.
2. 'Installed Certificate' section: Contains a 'Subject' field with the value 'C=TW, ST=, L=, O=, OU=, CN=' and a 'Date' field with the value 'Apr 23 09:05:24 2011 GMT'. Below these fields are two buttons: 'Content' and 'Remove'.
3. 'Connection Types' section: Features a dropdown menu currently set to 'Http&Https'.

Https setting: Before setting a new request, please remove the old security identification at the Http connection type.

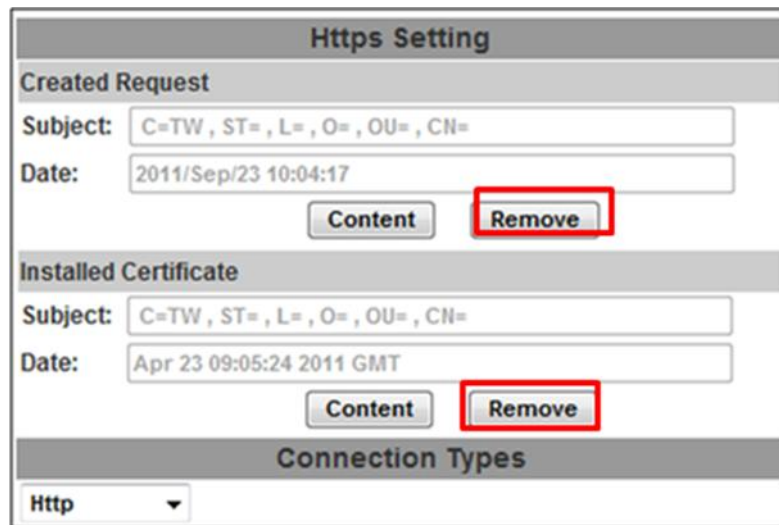

Https Setting

Created Request

Subject: C=TW , ST= , L= , O= , OU= , CN=

Date: 2011/Sep/23 10:04:17

Content Remove

Installed Certificate

Subject: C=TW , ST= , L= , O= , OU= , CN=

Date: Apr 23 09:05:24 2011 GMT

Content Remove

Connection Types

Http

1. Created Request: remove the security identification in Created request mode. A warning message will be shown. Please set “Yes” to remove the security identification.
2. Setting the security identification and apply it.



Https Setting

Create Request

Country:

State or province:

Locality:

Organization:

Organizational Unit:

Common Name:

Apply

3. Installed Certificate: Another warning message will be shown.
4. There are two ways to set: Install Signed Certificate and Create Self-Signed Certificate.

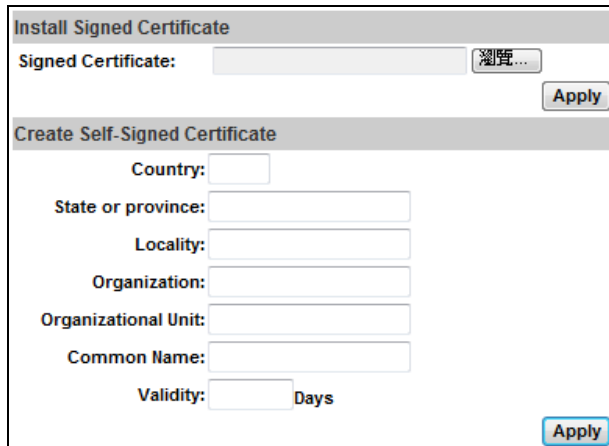

The screenshot shows a web interface for certificate management. It is divided into two sections: 'Install Signed Certificate' and 'Create Self-Signed Certificate'. The first section has a text input for 'Signed Certificate:' followed by a '浏览...' (Browse) button and an 'Apply' button. The second section contains several text input fields: 'Country:', 'State or province:', 'Locality:', 'Organization:', 'Organizational Unit:', and 'Common Name:'. Below these is a 'Validity:' field with a 'Days' label. An 'Apply' button is located at the bottom right of the second section.

b. SNMP(Simple Network Management Protocol):

1. Enable SNMPv1 or SNMPv2 and write the name of both Write Community and Read Community.
2. Enable SNMPv3. Set Security Name, Authentication Type, Authentication Password, Encryption Type, Encryption Password of Write mode and Read mode.
3. Enable SNMPv1/SNMPv2 Trap for detecting the Trap server. Please set what event needs to be detected.

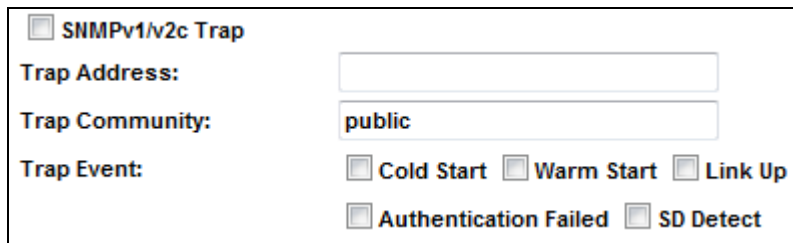

The screenshot shows the configuration for SNMPv1/v2c Trap. It features a checkbox labeled 'SNMPv1/v2c Trap'. Below it are three text input fields: 'Trap Address:', 'Trap Community:' (with the value 'public' entered), and 'Trap Event:'. The 'Trap Event:' field contains five checkboxes: 'Cold Start', 'Warm Start', 'Link Up', 'Authentication Failed', and 'SD Detect'.

- c. Access list:"Enable IP address filter" for setting the IP address which allows or denies the IP Camera. There are two options, single IP and range of IPs.

IP FILTER

IP ADDRESS FILTER Setting

Enable ip address filter

IPv4 Setting:

allow deny

address:

IPv4 List:

No.	IP Address	Filter	Action
1			<input type="button" value="remove"/>
2			<input type="button" value="remove"/>
3			<input type="button" value="remove"/>
4			<input type="button" value="remove"/>
5			<input type="button" value="remove"/>
6			<input type="button" value="remove"/>
7			<input type="button" value="remove"/>
8			<input type="button" value="remove"/>
9			<input type="button" value="remove"/>
10			<input type="button" value="remove"/>

Allow admin ip address always access this device

Admin ip address:

d. QoS/DSCP(Quality of Server/Differentiated Services Code-point):

DSCP specifies a simple mechanism for classifying and managing network traffic and provide QoS on IP networks. DSCP is a 6-bit in the IP header for packet classification purpose. Please define it for Live Stream, Event / Alarm and Management.

QoS/DSCP

QoS/DSCP Setting

Enable QoS/DSCP

Live Stream: (0~63)

Event / Alarm: (0~63)

Management: (0~63)

e. IEEE 802.1x:

IEEE 802.1x is an IEEE standard for port-based Network Access Control. It provides an authentication mechanism to a device on a LAN or WLAN.

The EAPOL protocol support service identification and optional point to point encryption over the local LAN segment.

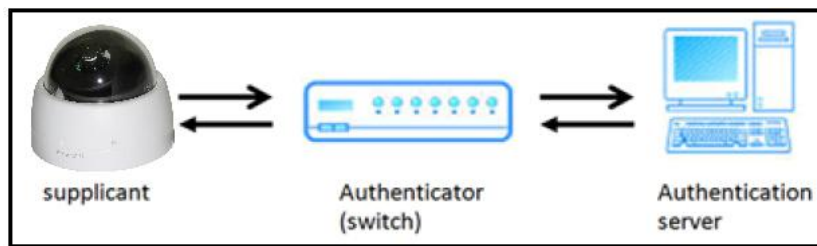

Please check what version of the authenticator and authentication server is supported. This camera supports EAP-TLS method. Enter the ID and password issued by the CA and then upload the related certificates.

IEEE 802.1x/EAP-TLS

IEEE 802.1x Setting

Enable IEEE 802.1x

Eapol version: v1 v2

Identity:

Private key password:

CA certificate:

Status:

Client certificate:

Status:

Client private key:

Status:

iii 、 PPPoE & DDNS:

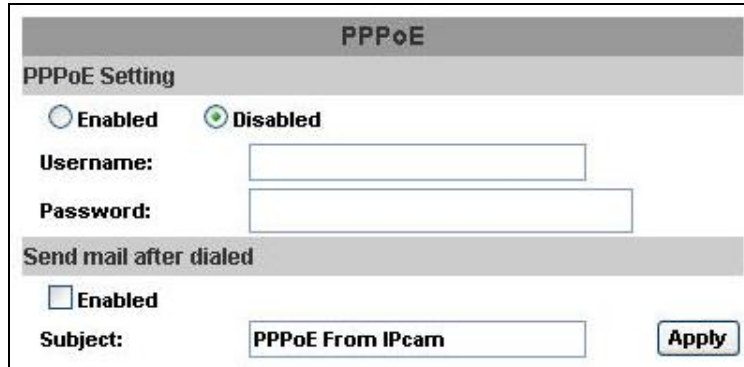

The screenshot shows the 'PPPoE' configuration page. At the top, there's a title bar 'PPPoE' and a sub-section 'PPPoE Setting'. Under this, there are two radio buttons: 'Enabled' (unselected) and 'Disabled' (selected). Below are two text input fields for 'Username:' and 'Password:'. A section titled 'Send mail after dialed' contains a checkbox for 'Enabled' (unselected) and a 'Subject:' field with the text 'PPPoE From IPCam'. An 'Apply' button is located at the bottom right.

a. PPPoE: Select “Enabled” to use PPPoE. Key-in Username and password for ADSL connection. Send mail after dialed: When it connects to the internet it will send a mail to a specific mail account.

b. DDNS:

It supports DDNS (Dynamic DNS) service.

1. DynDNS:

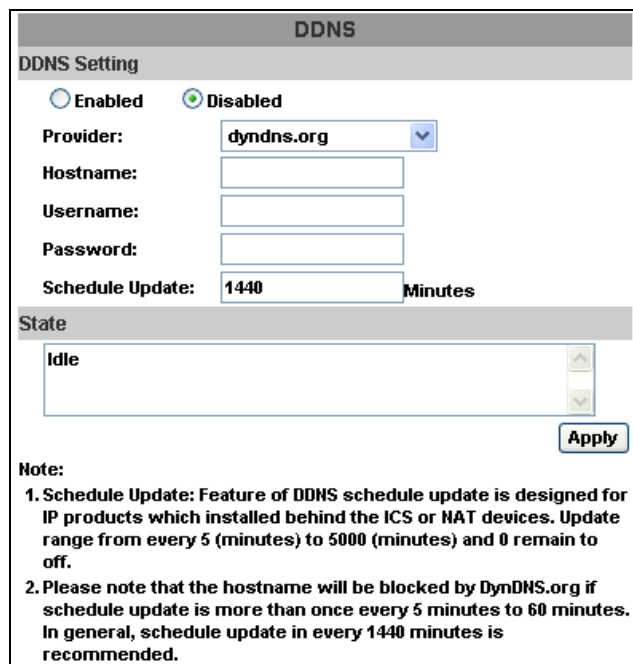

The screenshot shows the 'DDNS' configuration page. At the top, there's a title bar 'DDNS' and a sub-section 'DDNS Setting'. Under this, there are two radio buttons: 'Enabled' (unselected) and 'Disabled' (selected). Below are a dropdown menu for 'Provider:' (set to 'dyndns.org'), and text input fields for 'Hostname:', 'Username:', and 'Password:'. A 'Schedule Update:' field is set to '1440' with 'Minutes' next to it. A 'State' section contains a dropdown menu set to 'Idle'. An 'Apply' button is at the bottom right. Below the form, there is a 'Note:' section with two numbered points: 1. Schedule Update: Feature of DDNS schedule update is designed for IP products which installed behind the ICS or NAT devices. Update range from every 5 (minutes) to 5000 (minutes) and 0 remain to off. 2. Please note that the hostname will be blocked by DynDNS.org if schedule update is more than once every 5 minutes to 60 minutes. In general, schedule update in every 1440 minutes is recommended.

- (1) Enable this service
 - (2) Key-in the DynDNS server name, user name, and password.
 - (3) Set up the IP Schedule update refreshing rate.
 - (4) Click “Apply”
 - (5) If the schedule update is too frequently, the IP may be blocked. In general, an update every day (1440 minutes) is recommended
2. Camddns service:

DDNS

DDNS Setting

Enabled Disabled

Provider: ▼

Username:

Schedule Update: Minutes

State

Idle

Note:

1. Schedule Update: Feature of DDNS schedule update is designed for IP products which installed behind the ICS or NAT devices. Update range from every 5 (minutes) to 5000 (minutes) and 0 remain to off.
2. Please note that the hostname will be blocked by DynDNS.org if schedule update is more than once every 5 minutes to 60 minutes. In general, schedule update in every 1440 minutes is recommended.

1. Please enable this service
2. Key-in user name.

3. The IP schedule update default is 5 minutes

4. Click “Apply”.

3. DDNS Status

(1) Updating: Information update

(2) Idle: Stop service

(3) DDNS registration successful, can now log by <http://<username>.ddns.camddns.com>: Register successfully.

(4) Update Failed, the name is already registered: The user name has already been used. Please change it.

(5) Update Failed; please check your internet connection: Network connection failed.

(6) Update Failed, please check the account information you provided: The server, user name, and password may be wrong.

iv, Server settings

There are three choices of server: Email, FTP and SAMBA. Select the item for displaying detailed configuration options. You can configure either one or all of them.

To send out the video via mail of FTP, please set up the configuration first.

Server Settings	
Mail Setting	
Login Method:	Account ▾
Mail Server:	<input type="text"/>
Username:	<input type="text"/>
Password:	<input type="password"/>
Sender's Mail:	<input type="text"/>
Receiver's Mail:	<input type="text"/>
Bcc Mail:	<input type="text"/>
Mail Port:	25 (Default 25)
<input type="checkbox"/> Secure Connect:	<input checked="" type="radio"/> TLS <input type="radio"/> SSL
<input type="button" value="Test"/>	
FTP Setting	
Samba (Network storage)	
<input type="button" value="Apply"/>	

FTP

To send out the video via mail of FTP, please set up the configuration first.

FTP Setting	
FTP Server:	<input type="text"/>
Username:	<input type="text"/>
Password:	<input type="password"/>
Port:	21
Path:	/
Mode:	PORT ▾
Create the folder:	Yes ▾ (ex:Path/20100115/121032m.avi)
<input type="button" value="Test"/>	

Samba

Select this option to send the media files via a neighbor network when an event is triggered

Samba (Network storage)

Location: (ex:\\Nas_ip\folder)

Workgroup:

Username:

Password:

Create the folder: (ex:Path/20100115/121032m.avi)

C. A/V Setting

1. Image Setting

Privacy Mask

Area 1
Area 2
Area 3
Save

Image Setting

Brightness:	0		<div style="border: 2px solid red; width: 100px; height: 100px; margin: 0 auto;"></div> A
Contrast:	0		
Hue:	0		
Saturation:	0		
Sharpness:	0		
AGC: B	64x		
Shutter Time: C	Outdoor		
Sense-Up: D	1/15		
D-WDR: E	Off		
Video Orientation:	<input type="checkbox"/> Flip <input type="checkbox"/> Mirror		F
Day Lux: G	7 lux (about)	Night Lux:	3 lux (about)
Current Lux:	over 55 lux (about)		
Day & Night.	Light Sensor Mode		
White Balance: H	Red gain: 0	Blue gain:	0
Denoise: I	3D: 5	2D: 3	Default

For security and privacy purposes, there are three areas that can be set up for privacy. Click the Area button first, then drag an area on the above image. Remember to save your settings. The masked area will not be shown on both live view and recording image.

Please refer to the details below for image settings:

a. Brightness, Contrast, Hue, Saturation, Sharpness can be adjusted here.

b. AGC: The sensitivity of the camera can adjust to the environmental lighting. Enable this function for getting brighter image on low light, but the level of noise may also increase.

c. Shutter Time: Choose the location of your camera or fixed shutter time. The shorter the shutter time is the less light the camera receives and the image becomes darker.

d. Sense-Up: This function increases the sensitivity of camera to get brighter image at night. The smaller the value you select, the slower the shutter speed becomes so that the image will get brighter, and moving subjects might be blurred.

e. D-WDR: This function enables the camera to reduce the contrast in the view to avoid the dark zones resulting from over and under exposure. If the Input resolution is 30fps, the default value is fixed on ENABLED.

If the D-WDR is enables. The values for bright, dark and contrast can be adjusted.

f. Video Orientation: Flip or mirror the image.

g. Day & Night: The camera can detect the light level of the environment. If you choose "Light Sensor Mode", the image will be turned black and white at night in order to keep a clear image. To set light sensor mode, appoint a lux standard of switching D/N. Current lux value is provided for reference.

Under "Times Mode" the switch time of Color / Black and white will be according to the given time. You can also control it by choosing "Color" or "B/W".

h. White Balance: Adjust red / blue gain

i. Denoise: This function is able to filter the noise and blur from the image and show a clearer view.

3D denoise analyzes successive pictures to detect the noise places while.

2D denoise analyzes only single picture.

Note: When you select a number in "Shutter Time", actually the shutter time varies in a range and controlled by camera automatically. Following table shows the shutter time option and corresponding range

Option	Shutter Time Range (sec.)
Outdoor	1/10000 ~ Selected number in "Sense-up"
Indoor	NTSC: 1/120 ~ Selected number in "Sense-up" PAL: 1/100 ~ Selected number in "Sense-up"
1/30	1/10000 ~ 1/30
1/50	1/10000 ~ 1/50
1/60	1/10000 ~ 1/60
1/100	1/10000 ~ 1/100
1/125	1/10000 ~ 1/125
1/250	1/10000 ~ 1/250
1/500	1/10000 ~ 1/500
1/1000	1/10000 ~ 1/1000
1/10000	1/10000
* Sense-up options: 1/30, 1/15, 1/10, 1/5	

2. Video Setting

User may select the camera system type

Video Setting	
Video System:	<input type="text" value="PAL"/>

Streaming 1 Setting: Basic mode and Advanced mode

Streaming 2 Setting: Basic mode, Advanced mode, and 3GPP mode

(Max Video Frame Rate for both streaming combined is 30 FPS)

a. Streaming 1 & 2 Basic Mode:

Streaming 1 Setting	
<input checked="" type="radio"/> Basic Mode	<input type="radio"/> Advanced Mode
Resolution:	<input type="text" value="1280x800"/>
Quality:	<input type="text" value="High"/>
Video Frame Rate:	<input type="text" value="30 FPS"/>
Video Format:	<input type="text" value="H.264"/>
RTSP Path:	<input type="text" value=""/> ex:rtsp://IP_Address/ Audio:G.711

1. Resolution:

Stream 1

2592x1944@15fps, 2048x1536@15fps, 1920x1080@30fps,
1280x720@30fps, 640x480@30fps, 320x240@30fps,
176x144@30fps

Stream 2

640x480@30fps, 320x240@30fps, 176x144@30fps

2. Profile:

Profiles are different compression way of H.264. High profile provides better coding efficiency. Note that some devices do not support every profile. For example, iPhone4 only supports Main profile.

3. Quality:

There are 5 levels:

Best/ High/ Standard/ Medium/ Low

The higher the quality is, the bigger the file size is. Not good for internet transmission.

4. Video Frame Rate: The video refreshing rate per second.

5. Video Format: H.264, MPEG4 or M-JPEG

6. RTSP Path: RTSP output name

b. Streaming 1 & 2 Advanced Mode:

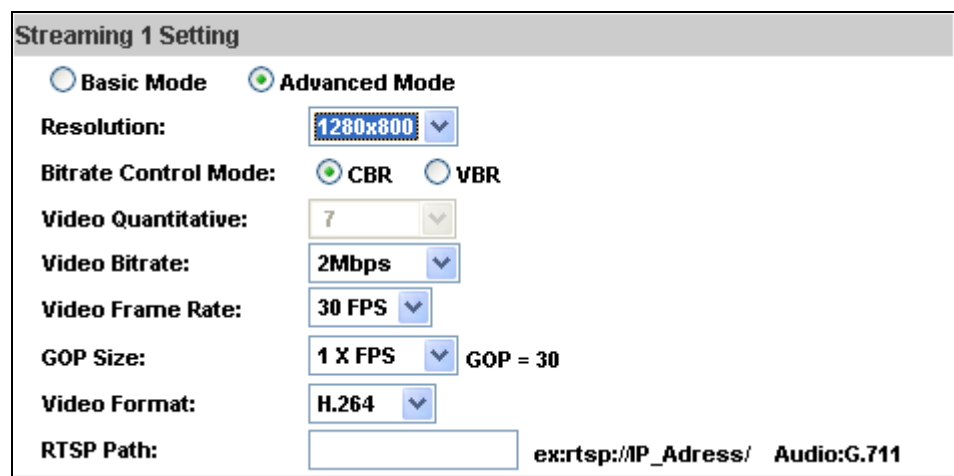

The screenshot shows a 'Streaming 1 Setting' dialog box with the following configuration:

- Mode:** Advanced Mode
- Resolution:** 1280x800
- Bitrate Control Mode:** CBR
- Video Quantitative:** 7
- Video Bitrate:** 2Mbps
- Video Frame Rate:** 30 FPS
- GOP Size:** 1 X FPS (GOP = 30)
- Video Format:** H.264
- RTSP Path:** ex:rtsp://IP_Address/ Audio:G.711

1. Resolution:

Stream 1

2592x1944@15fps, 2048x1536@15fps, 1920x1080@30fps,
1280x720@30fps, 640x480@30fps, 320x240@30fps,
176x144@30fps

Stream 2

640x480@30fps, 320x240@30fps, 176x144@30fps

2. Profile:

High profile provides better coding efficiency. Note that some devices do not support every profile. For example, iPhone4 only supports Main profile.

3. Bitrate Control Mode

There are CBR [Constant Bit Rate] and VBR [Variable Bit Rate]

CBR: 32Kbps~8Mbps (the higher the CBR is, the better the video quality is)

VBR: 1(Low) ~10(High) – Compression rate, the higher the compression rate, the lower the picture quality is; vice versa. The balance between VBR and network bandwidth will affect picture quality. Select the VBR rate to avoid picture breaking up or lagging.

4. Video Frame Rate

The video refreshing rate per second.

5. GOP Size

It means "Group of Pictures". The higher the GOP is, the better the quality is.

6. Video Format: H.264 or JPEG

7. RTSP Path: RTSP output connecting path

c. 3GPP Streaming mode:

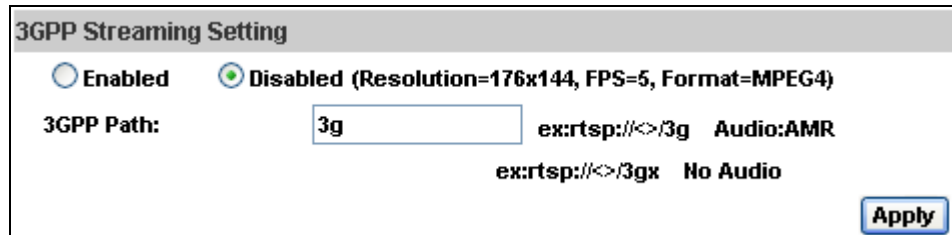

The screenshot shows a dialog box titled "3GPP Streaming Setting". It contains two radio buttons: "Enabled" (unselected) and "Disabled (Resolution=176x144, FPS=5, Format=MPEG4)" (selected). Below the radio buttons, there is a label "3GPP Path:" followed by a text input field containing "3g". To the right of the input field, there are two lines of text: "ex:rtsp://</>/3g Audio:AMR" and "ex:rtsp://</>/3gx No Audio". An "Apply" button is located in the bottom right corner of the dialog box.

The RTSP here is separated from the RTSP settings in the "IP SETTINGS".

3GPP Streaming can still work even if you select "disabled" in the RTSP server option of IP Setting.

1. Enable or Disable 3GPP Streaming

2. 3GPP Path: 3GPP output connecting path. If the IP address of your camera is 192.168.40.150, and you key-in "3g" in the column, the 3GPP path will be rtsp://192.168.40.150/3g.

3. Audio

The IP CAMERA supports 2-way audio. The user can send audio from the IP Camera built-in mic to the remote PC; the user can also send audio from remote PC to IP Camera's external speaker.

b. Audio from IP camera built-in mic to local PC: select "Enable" to start this function and also can select the audio type.

Audio

IP Camera to PC

Enabled Disabled

Audio Type: ▾

Adjust Volume

Mic-In: ▾

Line-Out: ▾

- c. Audio from local PC to IP Camera: Check “chatting” in the browsing page.

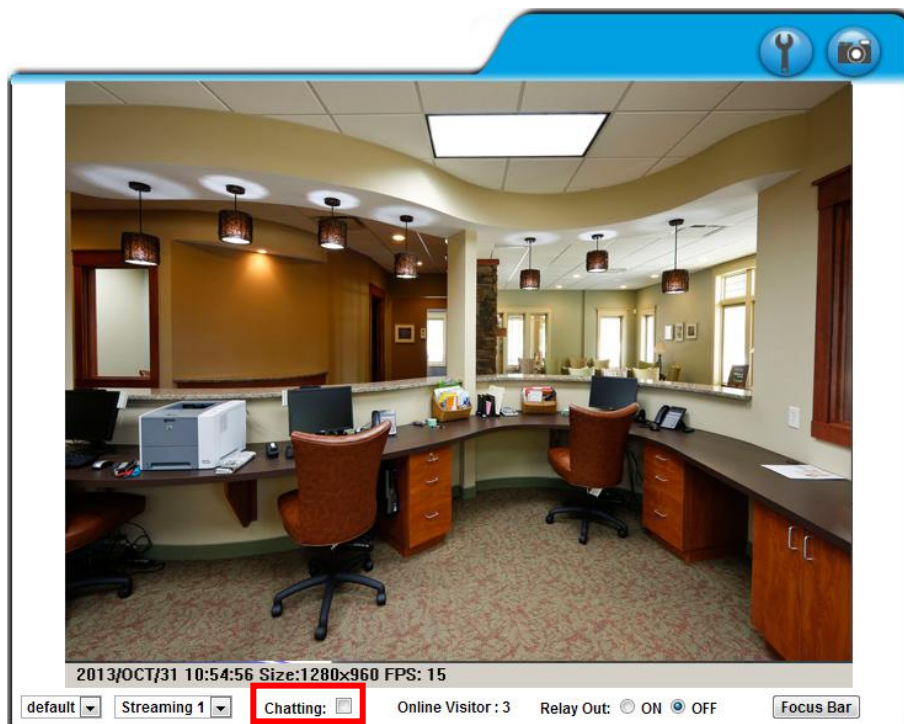

D. Event List

The IP Cam provides multiple event settings.

1. Event Setting

i. Motion Detection

To enable motion detection, please tick "Area 1/2/3". Click "Area 1/2/3" in Area Setting, and draw an area on the preview screen. When motion in the area is detected, "Motion!" word will be marked on the live screen, and the camera will send video or snapshot to the specific mail addresses, trigger the output device, or save video to FTP/ Micro SD card/ Samba.

If you select "save to SD card", the video or snapshot will be saved to Micro SD card. If you also tick E-mail/ FTP/ Samba of "Log" option, the motion detection log will be sent to E-mail/ FTP/ Samba simultaneously.

- Interval: If you select "10 sec" here, once the motion is detected and action is triggered, it cannot be triggered again within 10 seconds.

- Based on the schedule: When the option box is ticked, only during the selected schedule time the motion detection is enabled.

ii. Tampering Detection

When the camera view is covered, moved, shot by strong light, or out of focus, the tampering detection will be triggered, and send snapshot or video to mail/FTP/Samba/SD card, or trigger the external alarm. Please select the alarm action.

- Interval: The tampering detecting interval. Take the diagram below as example. By setting the interval on 30 seconds, the camera lens will be covered during 10- 40 sec. At time point B, the IP camera compares the view with time point A, and sends an alarm when it found that the lens is covered. At time point C, the camera compares the view with time point B, and sends an alarm when it found that the lens view is being blocked or uncovered.

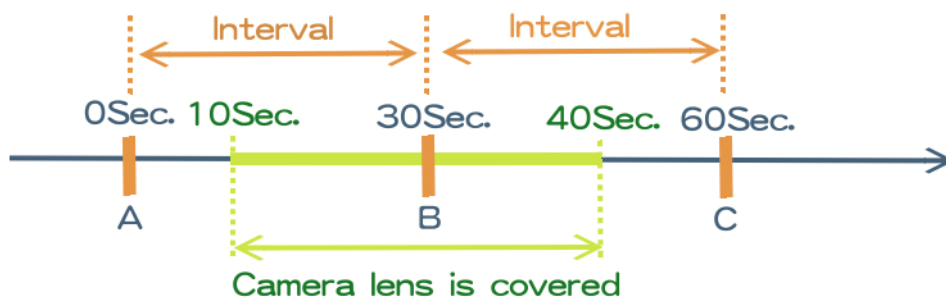

iii. Record File Setting: The IP Cam allows 3 different types of recording file to change its record size.

When motion/alarm is triggered, there are 3 different types of recording mode.

1. AVI File (With Record File Setting)
2. JPEG Files (With Record File Setting), only with JPEG compression format.
3. Single JPEG (Single File with Interval Setting)

iv. Record Time Setting:

Record Time Setting	
Pre Alarm:	5 sec
Post Alarm:	5 sec

When an event occurs, the IP camera can record a video clip or take a snapshot, and then send it via mail/ FTP/ Samba. Select the video recording length before and after the event is detected.

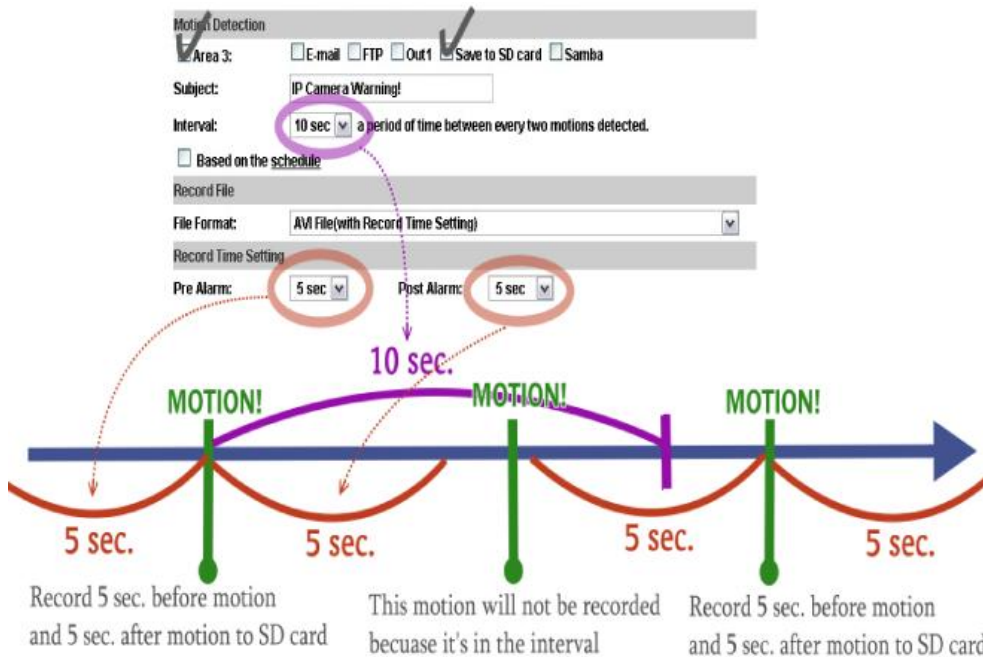

v. Network Dis-connected:

The IP Cam will scan the network. The image will be record to the SD card after the IP Camera detects network dis-connected, if set “Save to SD card”.

vi. Network IP check:

After enable IP Check, the IP camera can check if the network server is connecting. If the IP camera checking failed, the image will be recorded to the SD card.

Network Dis-connected	
Dis-connected:	<input type="checkbox"/> Save to SD card
Network IP Check	
IP Check:	<input checked="" type="radio"/> Enabled <input type="radio"/> Disabled
IP Address:	<input type="text" value="www.google.com"/>
Interval:	<input type="text" value="30 sec"/> ▾
IP Check:	<input type="checkbox"/> Save to SD card
<input type="button" value="Apply"/>	

2. Schedule

Schedule																								
All	0	1	2	3	4	5	6	7	8	9	10	11	12	13	14	15	16	17	18	19	20	21	22	23
Mon.																								
Tue.																								
Wed.																								
Thu.																								
Fri.																								
Sat.																								
Sun.																								

With schedule setup.

Snapshot	
<input type="radio"/> Enabled	<input checked="" type="radio"/> Disabled
Snapshot:	<input type="checkbox"/> E-mail <input type="checkbox"/> FTP <input type="checkbox"/> Save to SD card <input type="checkbox"/> Samba
Interval:	<input type="text" value="10"/> Second(s) [1..50000]
File Name:	<input type="text" value="Snapshot"/>
<input type="button" value="Apply"/>	

- a. Schedule: After completing the schedule setup, the camera data will be recorded according to the schedule setup.
- b. Snapshot: After enabling the snapshot function; the user can select the storage position of the snapshot file, the interval time of the snapshot and the reserved file name of the snapshot.
- c. Interval: The interval between two snapshots.

3. I/O Setting

I/O Setting	
Input Setting	
Input 1 Sensor:	N.O
Input 1 Action:	<input type="checkbox"/> E-mail <input type="checkbox"/> FTP <input type="checkbox"/> Out1 <input type="checkbox"/> Save to SD card <input type="checkbox"/> Samba
Subject:	GPIO In Detected!
Interval:	10 sec
<input type="checkbox"/> Based on the <u>schedule</u>	
Output Setting	
Mode Setting:	<input checked="" type="radio"/> OnOff Switch <input type="radio"/> Time Switch
Interval:	10 sec

a. Input Setting:

The IP Cam supports input and output. When the input condition is triggered, it will trigger the relay; and then send the video to mail addresses /FTP server / SAMBA.

- Interval:

For example, if you select "10 sec" here, once the motion is detected and the action is triggered, it cannot be triggered again

within 10 seconds.

- Based on the schedule:

When the option box is ticked, the I/O will be enabled only during the selected schedule time.

b. Output Setting:

The output mode affects the DO or relay out duration.

- (i) ON/Off Switch: The camera triggers the external device for 10 seconds. You can turn off the alarm manually by clicking “off” at the right bottom of the live video page.



- (ii) Time Switch: The camera triggers the external device and lasts for a certain time according to the internal setting; the user is not allowed to break off the alarm manually.

5. Log List

Log List	
System Logs	Logs
Motion Detection Logs	Logs
I/O Logs	Logs
All Logs	Logs

Sort by System Logs, Motion Detection Logs and I/O Logs. In addition, System Logs and I/O Logs won't lose data due to power failure.

6. SD card

a. Playback

Please Insert the Micro SD card before use it. Make sure to push the Micro SD card into the slot completely.

Click the date listed on this page and it shows the list of the video. The video format is AVI. Click the video to start Microsoft Media Player to play it. To delete the video, check it, and then click "Del".

2006/04/17			Del
Time	Video	Event Type	<input type="checkbox"/>
09:05:22	090522f.avi	Network Dis-connected	<input type="checkbox"/>
09:05:52	090552f.avi	Network Dis-connected	<input type="checkbox"/>
09:06:22	090622f.avi	Network Dis-connected	<input type="checkbox"/>
09:06:52	090652f.avi	Network Dis-connected	<input type="checkbox"/>
09:07:22	090722f.avi	Network Dis-connected	<input type="checkbox"/>
09:07:52	090752f.avi	Network Dis-connected	<input type="checkbox"/>
09:08:22	090822f.avi	Network Dis-connected	<input type="checkbox"/>
09:08:51	090851f.avi	Network Dis-connected	<input type="checkbox"/>
09:09:21	090921f.avi	Network Dis-connected	<input type="checkbox"/>
09:09:51	090951f.avi	Network Dis-connected	<input type="checkbox"/>

b. SD Management

When choosing “The 1st day “the recording file will be kept for one day. The oldest file will be deleted if the Micro SD card is full.

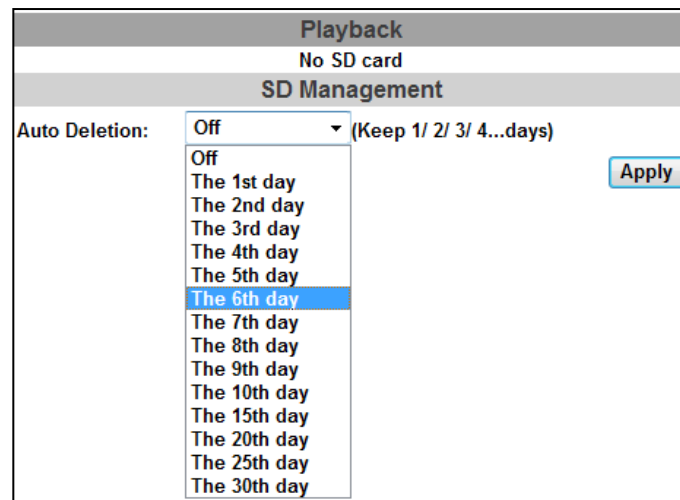

Note : The use of the SD card will slightly affect the operation of the IP Camera, such as frame rate of the video.

c. Copy to PC

You can insert the Micro SD card to the PC and read the files directly, or use FlashGet instead to download the files from the IP camera. (In this way you do not need to pull out the Micro SD card from the camera.)

To use FlashGet for downloading image and video data from the Micro SD card, please follow the steps:

(i) Enter into the data list and right-click "Files link daily", select "save target as..." then save the link list to the PC.



(ii) Open FlashGet, select "File" → "Import" → "Import list", and find the link list file you just saved. The file name may be called "SD_list".

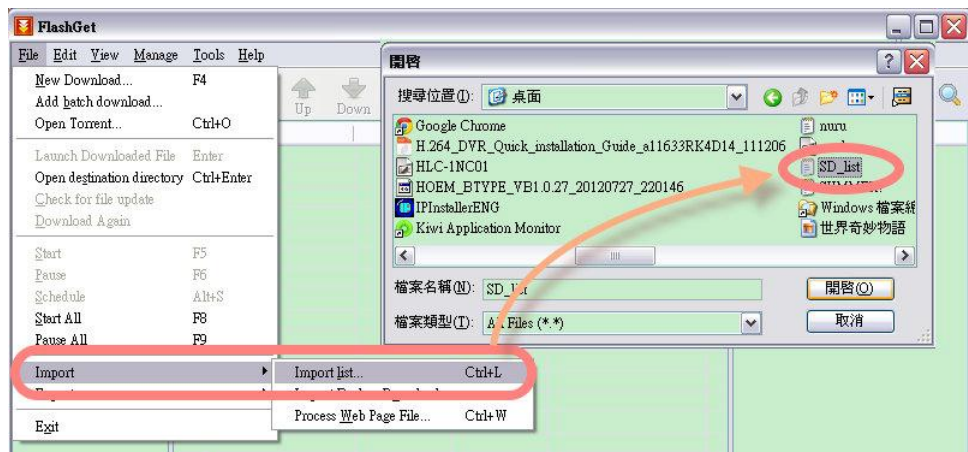

(iii) FlashGet will show you the link list, and you can tick the files you want to copy to your PC. Provide the directory path in the new download window, and remember to enable "Login to Server": Key-in the IP Camera username and password.

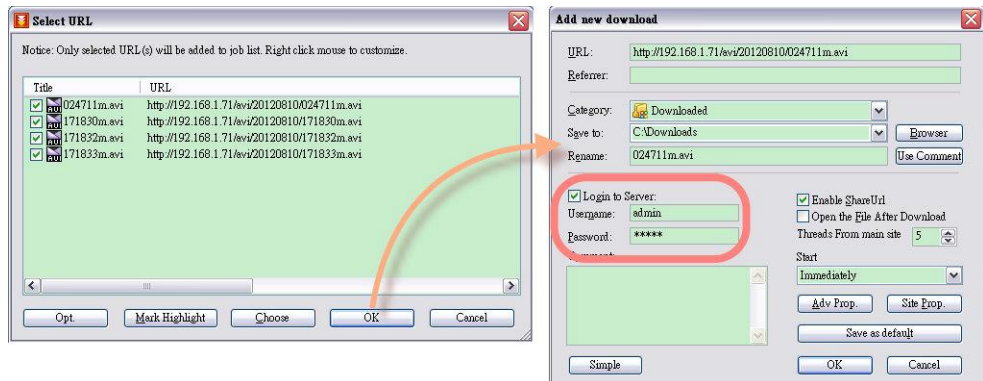

(iv) Click OK to start download.

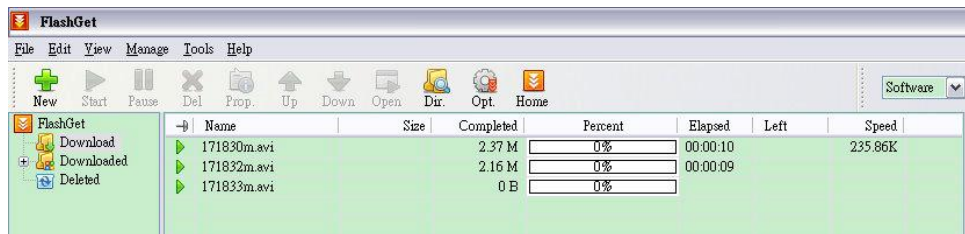

- FlashGet is a free software that can be downloaded from FlashGet official website. The example above is based on FlashGet ver.1.9.6.

VI. Network Configuration

i、 Configuration 1:

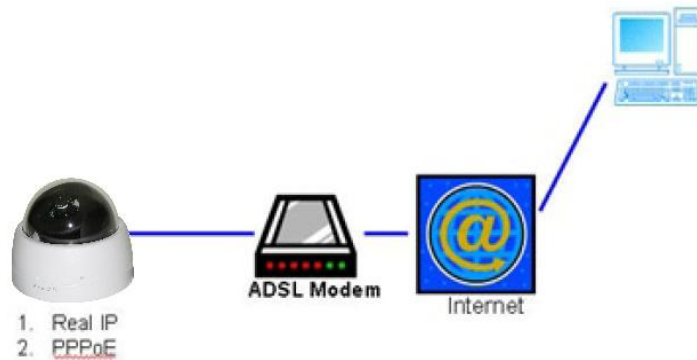

- a. Internet Access: ADSL or Cable Modem
- b. IP address: One real IP or one dynamic IP
- c. Only the IP CAMERA is connected to the internet
- d. For fixed real IP, set up the IP into IP CAMERA. For dynamic IP, start PPPoE.

ii、 Configuration 2 :

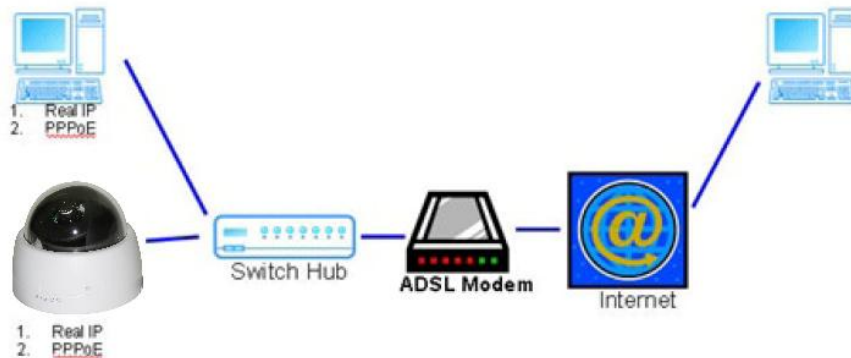

- a. Internet Access: ADSL or Cable Modem
- b. IP address: More than one real IP or one dynamic IP
- c. IP CAMERA and PC connect to the internet

- d. Device needed: Switch Hub
- e. For fixed real IP, set up the IP into IP CAMERA and PC. For dynamic IP, start PPPoE.

iii - Configuration 3:

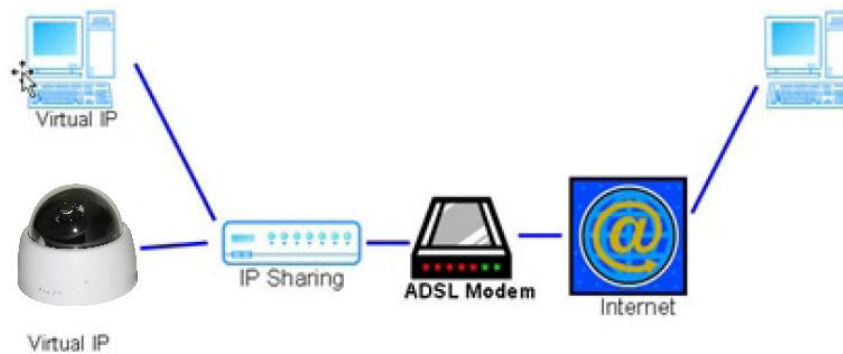

- a. Internet Access: ADSL or Cable Modem
- b. IP address: one real IP or one dynamic IP
- c. IP CAMERA and PC connect to the internet
- d. Device needed: IP sharing
- e. Use virtual IP, set up port forwarding in IP sharing.

VII. I/O Configuration

1. I/O Connection

- a. Please connect the GND & DO pin to the external relay (buzzer) device. Please connect the GND & DI pin to the external trigger device.

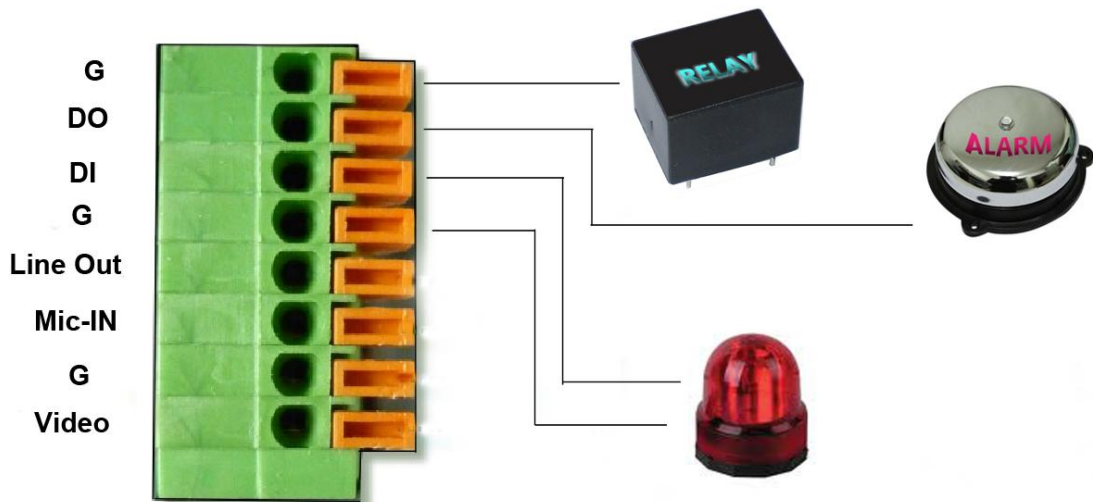

When no event occurs, DO output is 5V (DO and GND are disconnected). When the camera detects event triggers the external alarm, DO output is 0V (DO and GND are connected).

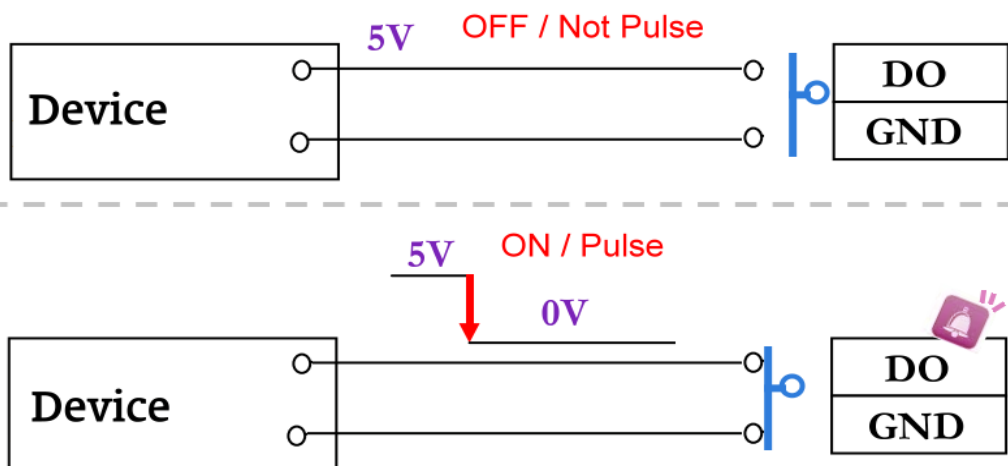

If you select "N.O" in "Input sensor setting", when the device or circuit makes DI and GND pin connected, the camera input alarm is triggered, and executes the action user has set, for example, send snapshot to E-mail address.

If you select "N.C" in "Input sensor setting", when the external device or circuit makes DI and GND pin disconnected, the camera input alarm is triggered, and executes the action user has set, for example, send snapshot to E-mail address.

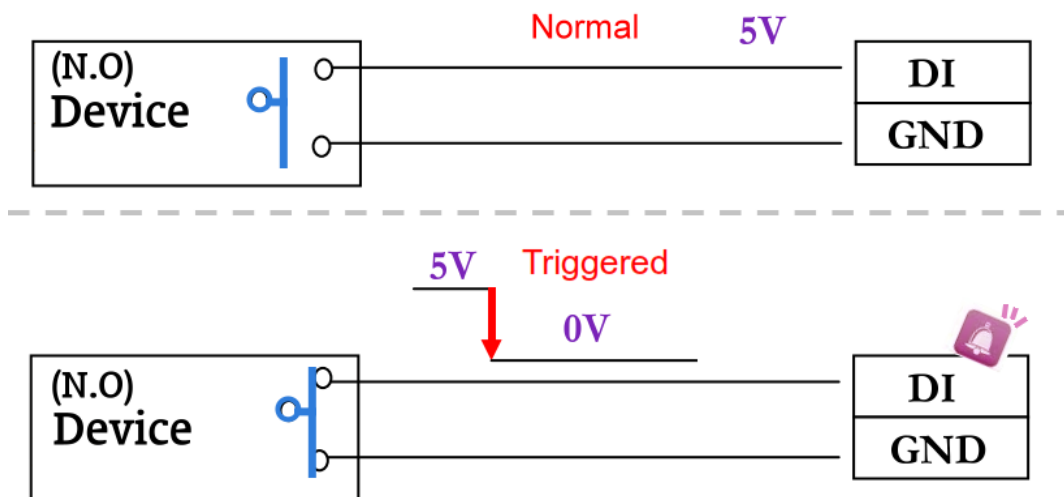

b. I/O PIN definition

- G (Ground): Initial state is LOW
- DO (Digital Output): DC 5V
- DI (Digital Input): Max. 50mA, DC 5V

2. I/O Setup

- a. Click I/O Setting from the system setup page via IE, and check "Out1" to enable I/O signal.

I/O Setting

Input Setting

Input 1 Sensor:

Input 1 Action: E-mail FTP Out1 Save to SD card Samba

Input 2 Sensor:

Input 2 Action: E-mail FTP Out1 Save to SD card Samba

Subject:

Interval:

Based on the schedule

Output Setting

Mode Setting: OnOff Switch Time Switch

Interval:

b.

Output Test

After the external input and output hardware is installed, you can use the "Relay Out" bottom on the live video page to test if DO / Relay Out works.

(i) On Off Switch mode:

Clicking "ON" will trigger the external output device for 10 seconds. For example, your alarm buzzer will continuously ring for 10 seconds. After 10 seconds the buzzer stops ringing, or you can manually break off the output signal by clicking "OFF".

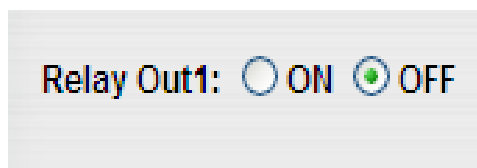

(ii) Time Switch mode:

Click "Pulse", the camera will trigger the external output device for several seconds; the duration length is according to the "interval" setting in Output Setting.



Relay Out 1:

VIII. Factory Default

If you forget your password, please follow the steps to revert back to default value.

- Remove the power and Ethernet cable. Press and hold the button in the picture below.



- Connect the power to the camera again, and do not release the button during the system booting.
- It will take around 30 seconds to boot the camera.
- Release the button when camera finished booting.
- Plug-in the Ethernet cable. Re-login the camera using the default IP (<http://192.168.1.200>), and user name (admin), password (admin).

IX. Universal Password

If you forgot the password of your IP camera, you can reset the camera to factory default, or follow the procedure below to generate a universal password.

Note: Universal password will be valid only when you enable the function in “User Management”.

1. First, you need to know the IP address and MAC of your IP camera. You can use IP installer to scan the LAN, and see the IP address and MAC on the side column.

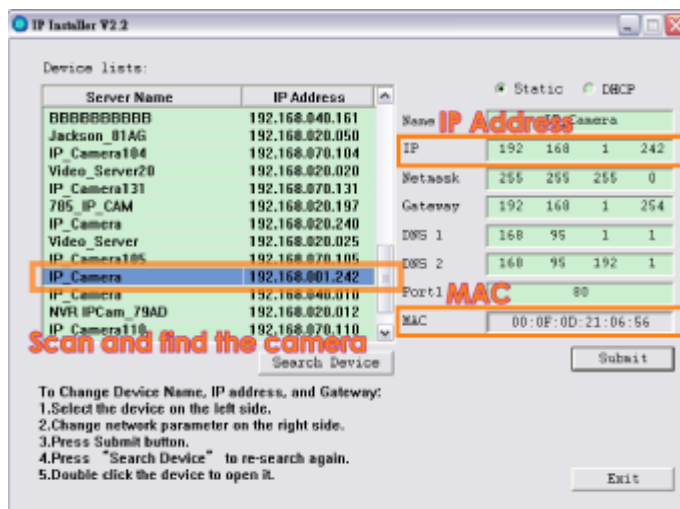

Or, if you already know the IP address of camera: Open the web browser, key in “http:// (IP address) /GetIPMAC.cgi” and press enter. The IP address and MAC will be displayed on browser.

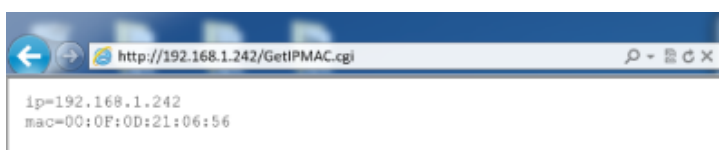

2. Find the .html file named “Universal Password” in CD-ROM. Click to open it.



3. Key in the camera IP address “IP Addr.” column and MAC in “MAC” column, and then click “encoder”. You will see a set of username and password appear, as below:



The screenshot shows a web interface for generating a universal password. It has the following fields and values:

- IP Addr: 192.168.1.242
- MAC: 00:0F:0D:21:06:56
- UserName: C90848
- Password: CNCE_U6KLA
- encoder: A button with an orange arrow pointing to it.

The universal username and password are generated from the IP address and MAC you key in, so if you change the camera IP address the universal password changes, too.

4. Take the picture for example, the universal username is “C90848” and password is “CNCE_U6KLA”. Use them to log in the camera.

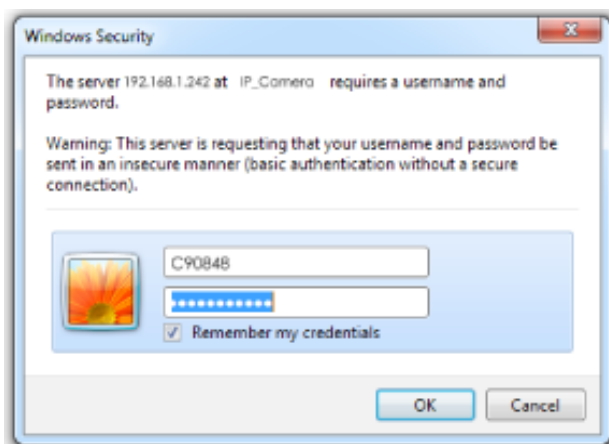



5. Now you can login as the administrator. The use of universal password does not affect the previous user settings, so the administrator account password will not change until you edit it. Please click “Edit” to give a new administrator password.

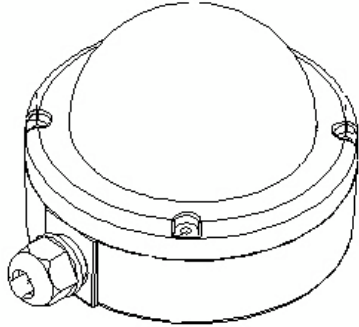
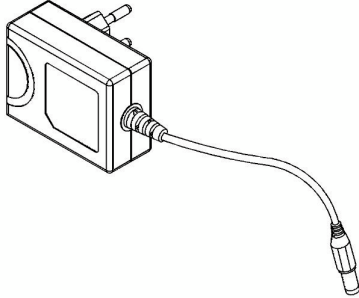
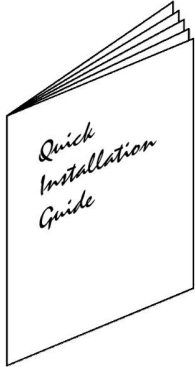
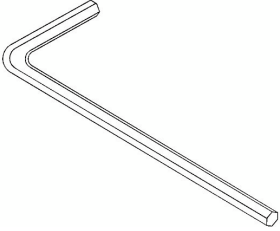
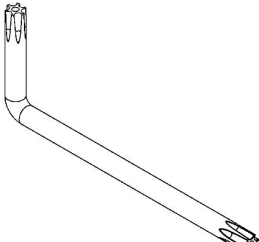
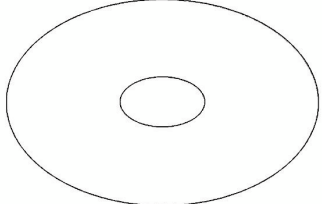
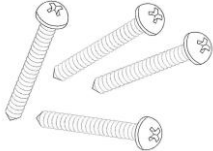

X. Package contents

- The CD includes user manual and software tools

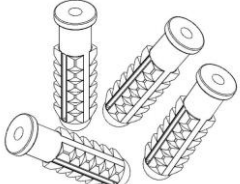
<p>IP Camera</p> 	<p>Adaptor</p> 	<p>Quick Installation Guide</p> 
<p>Hex Wrench</p> 	<p>Star Wrench</p> 	<p>CD</p> 
<p>Screws x4</p>	<p>O-ring x4</p>	<p>Wall Plug x4</p>
		

XI. Micro SD Card Compatibility

The following Micro SD Cards are recommended:

Transcend	SDHC	class4	16GB
	SDHC	class4	32GB
	SD	class4	16GB
	SD	class4	32GB
	SDHC	class6	4GB
	SDHC	class6	8GB
	SDHC	class6	16GB
	SD	class6	4GB
	SD	class6	8GB
	SD	class6	16GB
SanDisk	SDHC	class4	4GB
	SDHC	class4	8GB
	SDHC	class4	16GB