

USER MANUAL

PLUS2

CUSTOM  M[®]

CUSTOM S.p.A.
Via Berettine 2/B
43010 Fontevivo (PARMA) - Italy
Tel. : +39 0521-680111
Fax : +39 0521-610701
http: www.custom.biz

Customer Service Department:
Email : support@custom.it

© 2014 CUSTOM S.p.A. – Italy.
All rights reserved. Total or partial reproduction of this manual in whatever form, whether by printed or electronic means, is forbidden. While guaranteeing that the information contained in it has been carefully checked, CUSTOM S.p.A. and other entities utilized in the realization of this manual bear no responsibility for how the manual is used.
Information regarding any errors found in it or suggestions on how it could be improved are appreciated. Since products are subject to continuous check and improvement, CUSTOM S.p.A. reserves the right to make changes in information contained in this manual without prior notification.

The pre-installed multimedia contents are protected from Copyright CUSTOM S.p.A. Other company and product names mentioned herein may be trademarks of their respective companies. Mention of third-party products is for informational purposes only and constitutes neither an endorsement nor a recommendation. CUSTOM S.p.A. assumes no responsibility with regard to the performance or use of these products.

THE IMAGES USED IN THIS MANUAL ARE USED AS AN ILLUSTRATIVE EXAMPLES. THEY COULDN'T REPRODUCE THE DESCRIBED MODEL FAITHFULLY.

UNLESS OTHERWISE SPECIFIED, THE INFORMATION GIVEN IN THIS MANUAL ARE REFERRED TO ALL MODELS IN PRODUCTION AT THE ISSUE DATE OF THIS DOCUMENT.



The format used for this manual improves use of natural resources reducing the quantity of necessary paper to print this copy.

GENERAL SAFETY INFORMATION

Your attention is drawn to the following actions that could compromise the characteristics of the product:

- Read and retain the instructions which follow.
 - Follow all indications and instructions given on the device.
 - Make sure that the surface on which the device rests is stable. If it is not, the device could fall, seriously damaging it.
 - Make sure that the device rests on a hard (non-padded) surface and that there is sufficient ventilation.
 - When positioning the device, make sure cables do not get damaged.
 - Use the type of electrical power supply indicated on the device label. If uncertain, contact your dealer.
 - Make sure the electrical system that supplies power to the device is equipped with a ground wire and is protected by a differential switch.
 - Do not block the ventilation openings.
 - Do not insert objects inside the device as this could cause short-circuiting or damage components that could jeopardize printer functioning.
 - Do not carry out repairs on the device yourself, except for the normal maintenance operations given in the user manual.
 - Make sure that there is an easily-accessible outlet with a capacity of no less than 10A closely to where the device is to be installed.
 - Periodically perform scheduled maintenance on the device to avoid dirt build-up that could compromise the correct, safe operation of the unit.
 - Before any type of work is done on the machine, disconnect the power supply.
 - Do not touch the head heating line with bare hands or metal objects. Do not perform any operation inside the printer immediately after printing because the head and motor tend to become very hot.
- GENERAL INSTRUCTIONS
CUSTOM S.p.A. declines all responsibility for accidents or damage to persons or property occurring as a result of tampering, structural or functional modifications, unsuitable or incorrect installations, environments not in keeping with the equipment's protection degree or with the required temperature and humidity conditions, failure to carry out maintenance and periodical inspections and poor repair work.



THE CE MARK AFFIXED TO THE PRODUCT CERTIFY THAT THE PRODUCT SATISFIES THE BASIC SAFETY REQUIREMENTS.

The device is in conformity with the essential Electromagnetic Compatibility and Electric Safety requirements laid down in Directives 2006/95/CE and 2004/108/CE inasmuch as it was designed in conformity with the provisions laid down in the following Standards:

- EN 55022 Class B (*Limits and methods of measurements of radio disturbance characteristics of Information Technology Equipment*)
- EN 55024 (*Information Technology Equipment – Immunity characteristics – Limits and methods of measurement*)
- EN 60950-1 (*Safety of information equipment including electrical business equipment*)



GUIDELINES FOR THE DISPOSAL OF THE PRODUCT

The crossed-out rubbish bin logo means that used electrical and electronic products shall NOT be mixed with unsorted municipal waste. For more detailed information about recycling of this product, refer to the instructions of your country for the disposal of these products.

- Do not dispose of this equipment as miscellaneous solid municipal waste, but arrange to have it collected separately.
- The re-use or correct recycling of the electronic and electrical equipment (EEE) is important in order to protect the environment and the wellbeing of humans.
- In accordance with European Directive WEEE 2002/96/EC, special collection points are available to which to deliver waste electrical and electronic equipment and the equipment can also be handed over to a distributor at the moment of purchasing a new equivalent type.
- The public administration and producers of electrical and electronic equipment are involved in facilitating the processes of the re-use and recovery of waste electrical and electronic equipment through the organisation of collection activities and the use of appropriate planning arrangements.
- Unauthorised disposal of waste electrical and electronic equipment is punishable by law with the appropriate penalties.

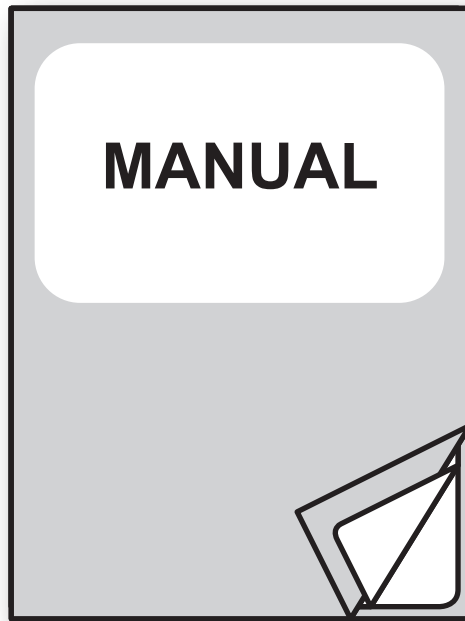

For details on the commands,
refer to the manual with code **77200000002100**

TABLE OF CONTENTS

1	INTRODUCTION	9
1.1	Document structure	9
1.2	Explanatory notes used in this manual	9
2	DESCRIPTION	11
2.1	Box content	11
2.2	Device components	12
2.3	Product label	13
2.4	Key functions: power up	14
2.5	Key functions: standby	15
2.6	Status led flashes	16
3	INSTALLATION	17
3.1	“EASYLOCK” fixing system	17
3.2	Fixing with screws	19
3.3	Collections	21
3.4	Pinout	23
3.5	Serial port setting	25
3.6	Driver and SDK	27
4	OPERATION	29
4.1	Loading the paper roll	29
5	CONFIGURATION	31
5.1	Configuration mode	31
5.2	Setup report	32
5.3	Printer status	33
5.4	Printer parameters	34
5.5	Hexadecimal dump	37
6	MAINTENANCE	39
6.1	Planning of cleaning operations	39
6.2	Cleaning	40
6.3	Upgrade firmware	43

7	SPECIFICATION	45
7.1	Hardware specifications	45
7.2	Character specifications in ESC/POS™ and PLUS emulation	48
7.3	Printer dimensions	49
7.4	Power supply dimensions cod. 964GE010000003	50
7.5	Paper specification	51
7.6	Character sets in ESC/POS™ and PLUS emulation	52
8	CONSUMABLES	55
9	ACCESSORIES	57
9.1	Grey frame 112X112	58
10	TECHNICAL SERVICE	63

1 INTRODUCTION

1.1 Document structure

This document includes the following chapters:

1	INTRODUCTION	information about this document
2	DESCRIPTION	general description of device
3	INSTALLATION	information required for a correct installation of the device
4	OPERATION	information required to make the device operative
5	CONFIGURATION	description of the configuration parameters of the device
6	MAINTENANCE	information for a correct periodic maintenance
7	SPECIFICATION	technical specification for the device and its accessories
8	CONSUMABLES	description and installation of the available consumables for the device
9	ACCESSORIES	description and installation of the available accessories for the device
11	TECHNICAL SERVICE	information required for contacting the technical service

1.2 Explanatory notes used in this manual

NOTE:

Gives important information or suggestions relative to the use of the device

ATTENTION:

Gives information that must be carefully followed to guard against damaging the device

DANGER:

Gives information that must be carefully followed to guard against operator injury or damage

2 DESCRIPTION

2.1 Box content

Remove the device from its carton being careful not to damage the packing material so that it may be re-used if the printer is to be transported in the future.

Make sure that all the components illustrated below are present and that there are no signs of damage. If there are, contact Customer Service.

1. Fixing clips (no. 2)
2. Paper roll
3. Printer
4. Installation instructions

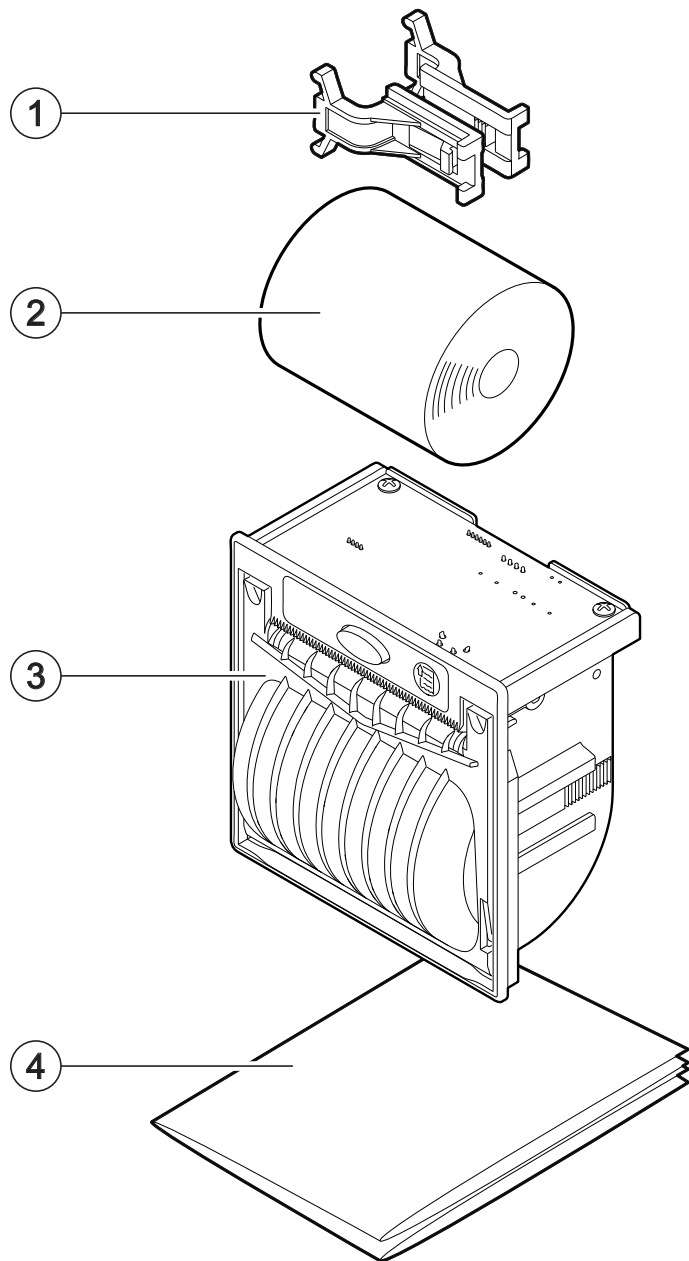

- Open the device packaging.
- Take out the device.
- Take out the rest of the content.
- Keep the box, trays and packing materials in the event the printer must be transported/shipped in the future.

2.2 Device components

1. Socket for 8-42 Vdc extended range module
2. Power supply port
3. USB port
4. RS232/TTL serial port
5. Sensor for paper detection
6. FEED key
7. OPEN key and status led
8. Paper out with serrated blade
9. Paper compartment
10. Switch for RS232/TTL serial communication

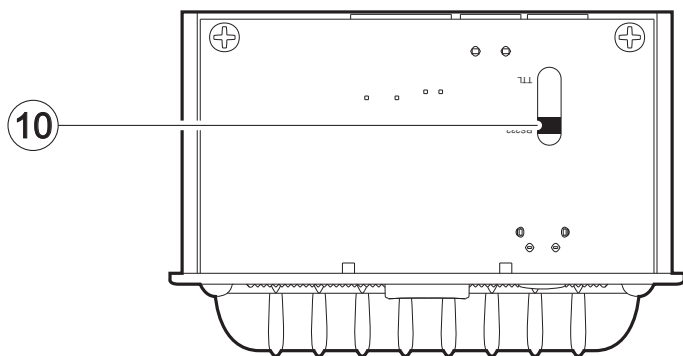
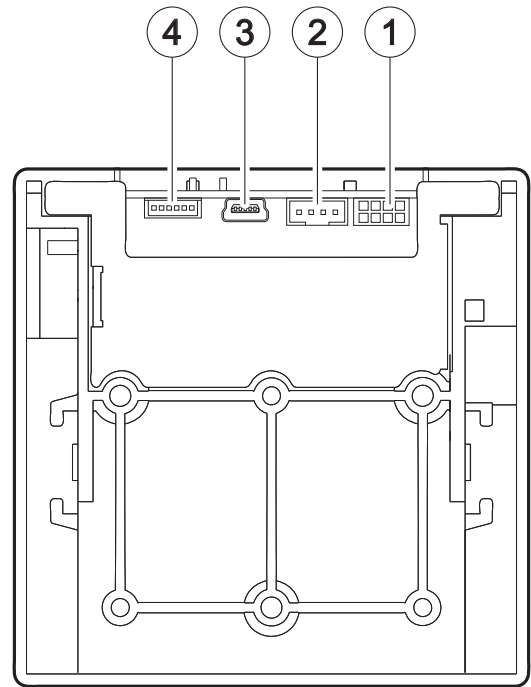
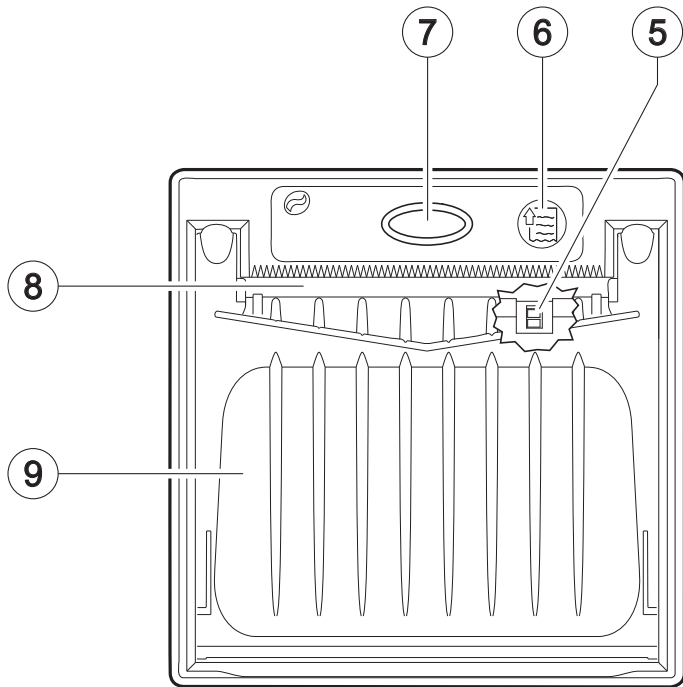

2.3 Product label

PC = Product code (14 digits)
SN = Serial number
HW = Hardware release

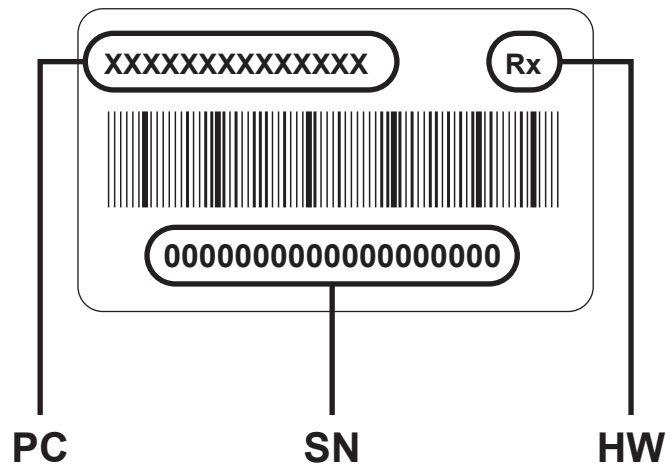

2.4 Key functions: power up

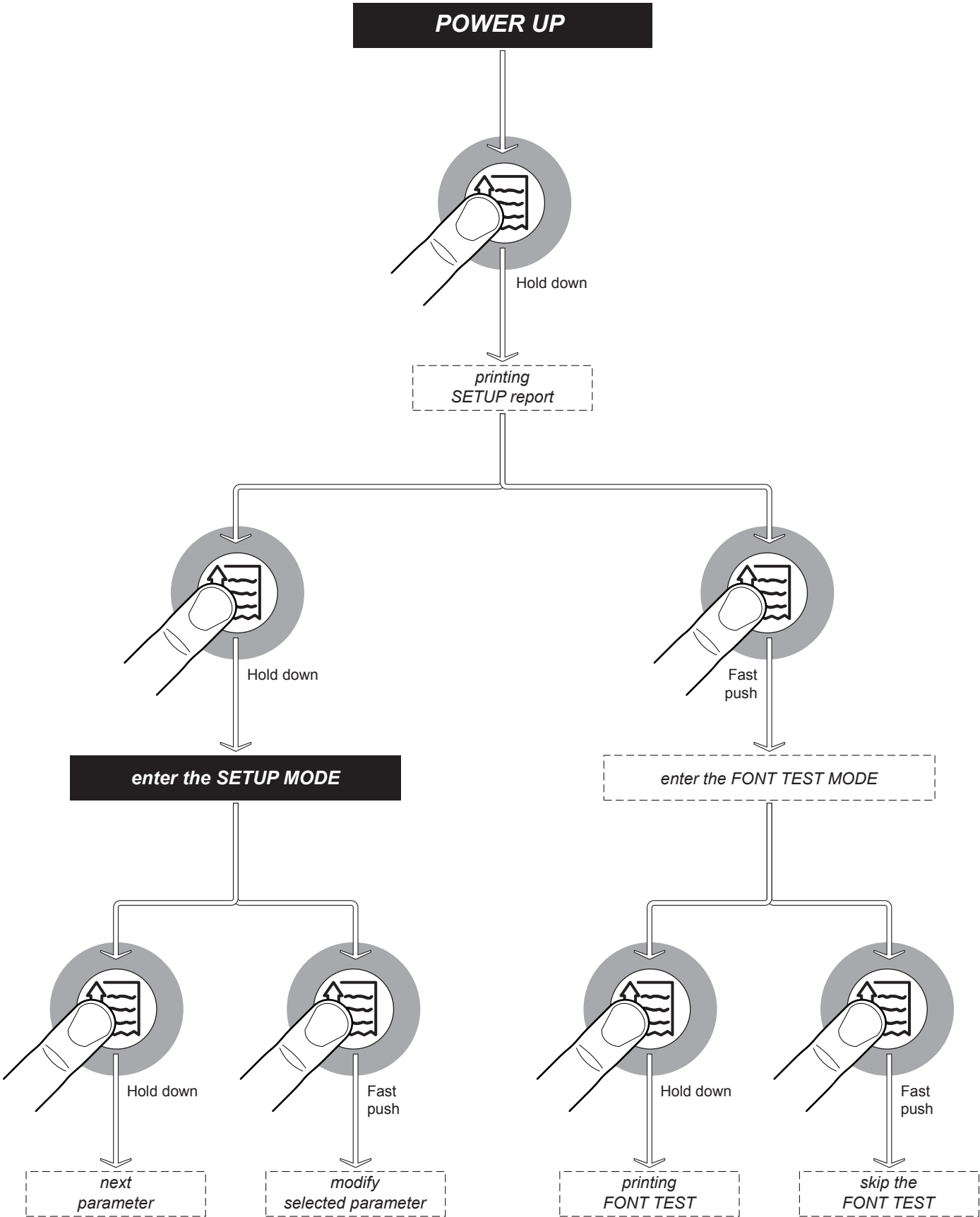

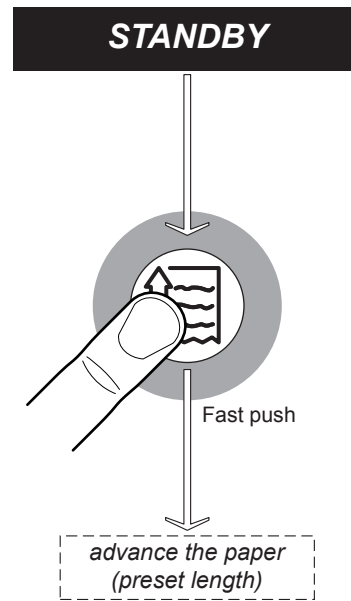

2.5 Key functions: standby



2.6 Status led flashes

The status of the device is sent to the serial port. To get a visual feedback of the signalings is necessary to build a cable to be connected to the serial port (see par. 3.3).

The Status led indicates hardware status of device. Given in the table below are the various led signals and the corresponding device status.

STATUS LED		DESCRIPTION
	OFF	PRINTER OFF
	ON	PRINTER ON: NO ERROR
	x 2	HEADING OVER TEMPERATURE
	x 3	PAPER END
	x 4	POWER SUPPLY VOLTAGE INCORRECT
	x 5	RECEPTION ERRORS (PARITY, FRAME ERROR, OVERRUN ERROR)
	x 6	COMMAND NOT RECOGNIZED
	x 7	COMMAND RECEPTION TIME OUT

3 INSTALLATION

3.1 "EASYLOCK" fixing system

The device includes two plastic clips for fixing to the panel. This system allows you to lock the machine on the panels of thickness max. 8mm and requires no tools. Proceed as follows:

NOTE: All the dimensions shown in following figures are in millimetres.

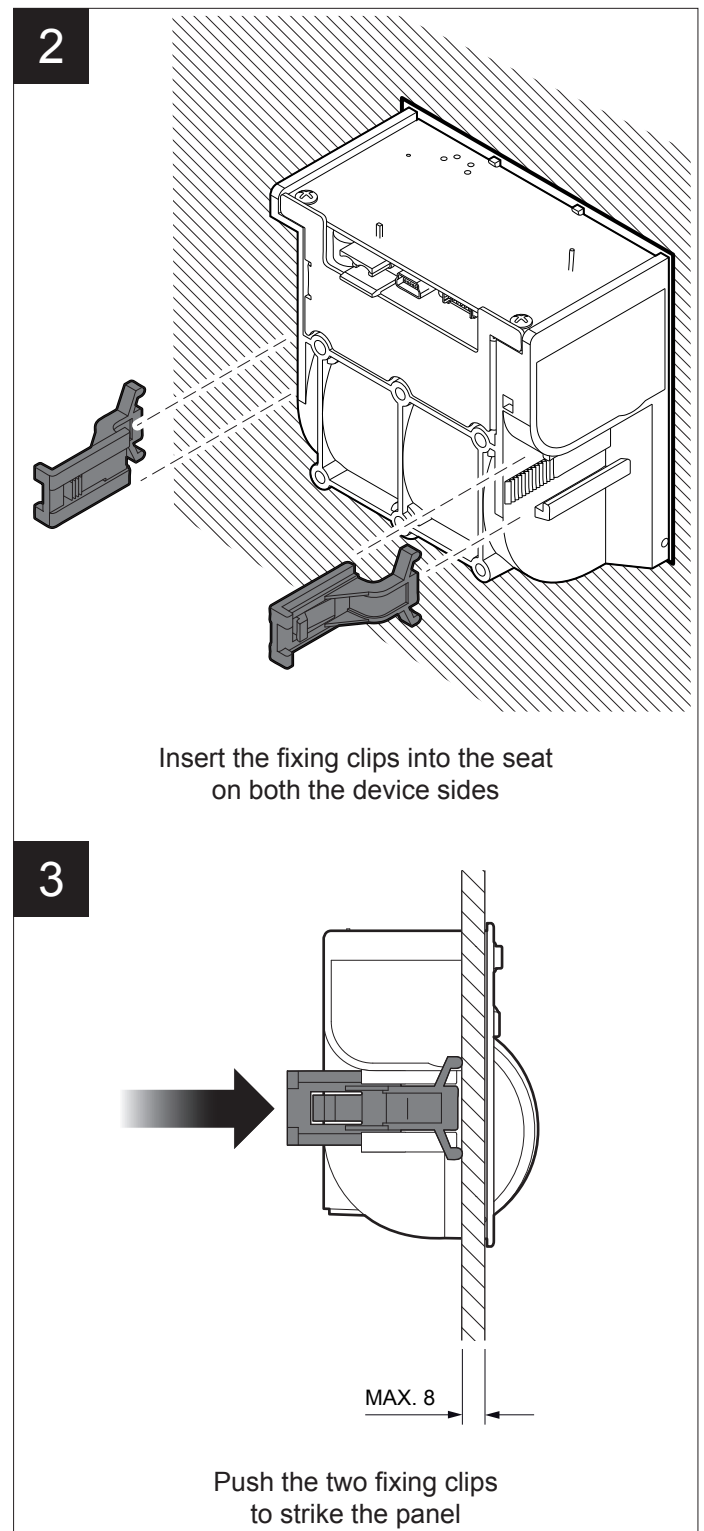
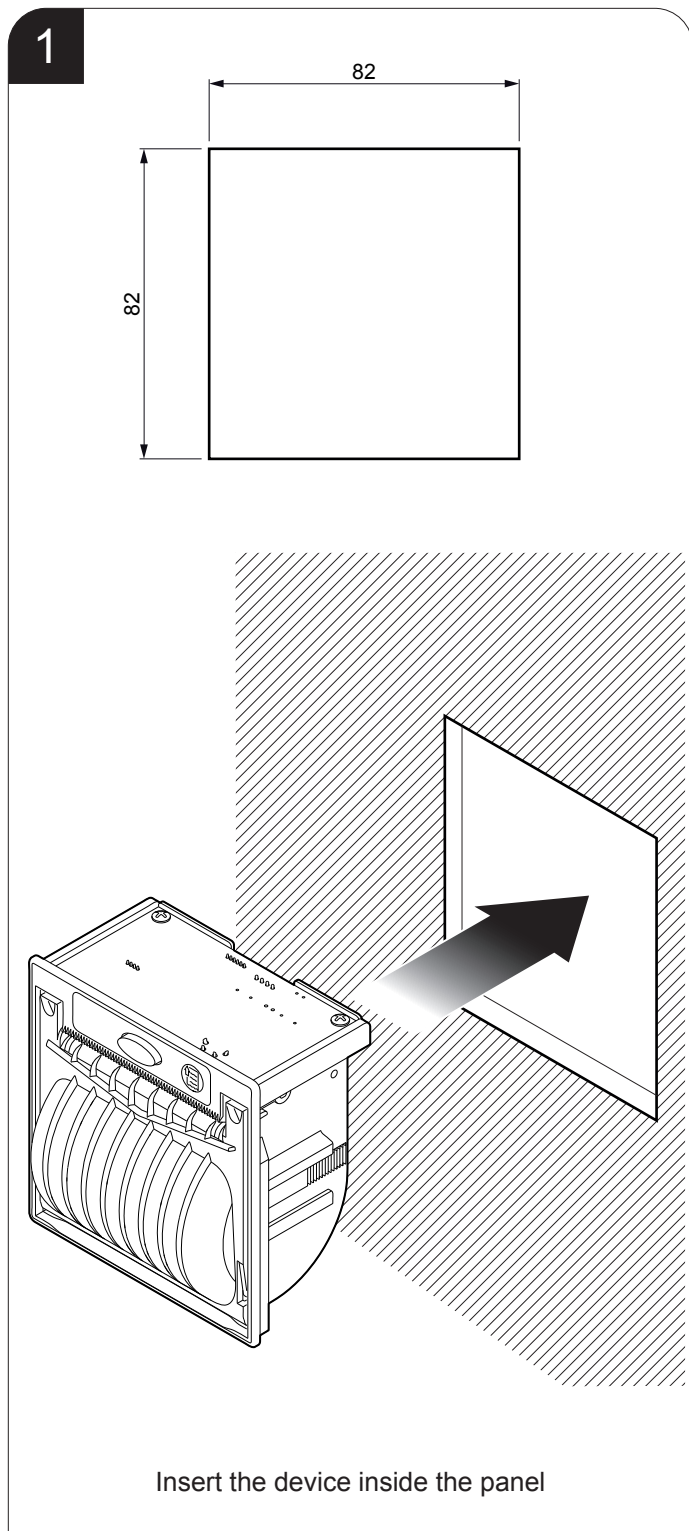

4

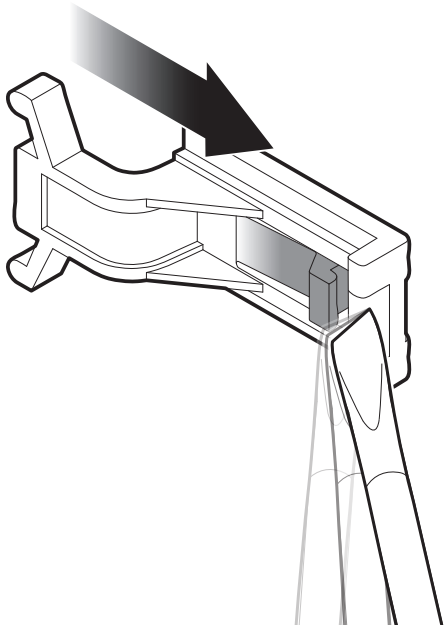

To remove the fixing clips
lift the lever shown in figure
with a small screwdriver

3.2 Fixing with screws

The device can be secured to the panel with 3 screws (not supplied) to be tighten on the rear side of the device (SCHEME A) or from the paper compartment (SCHEME B).

SCHEME A

Fixing on the rear side

No.3 self-tapping screws for plastic d = 3

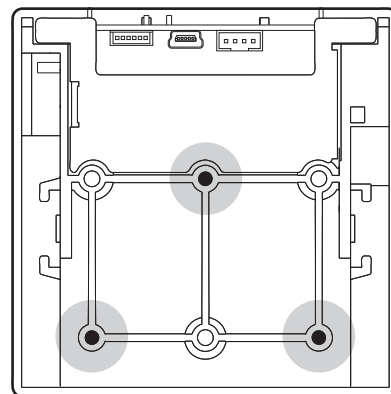
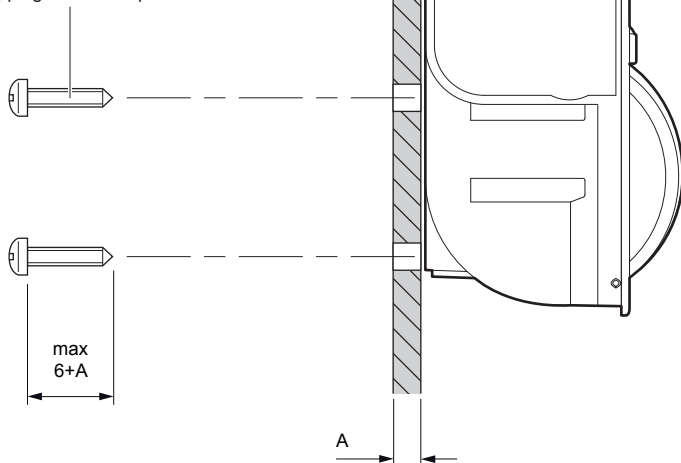

SCHEME B

Fixing from paper compartment

No.3 threaded nut

No.3 M3 screws

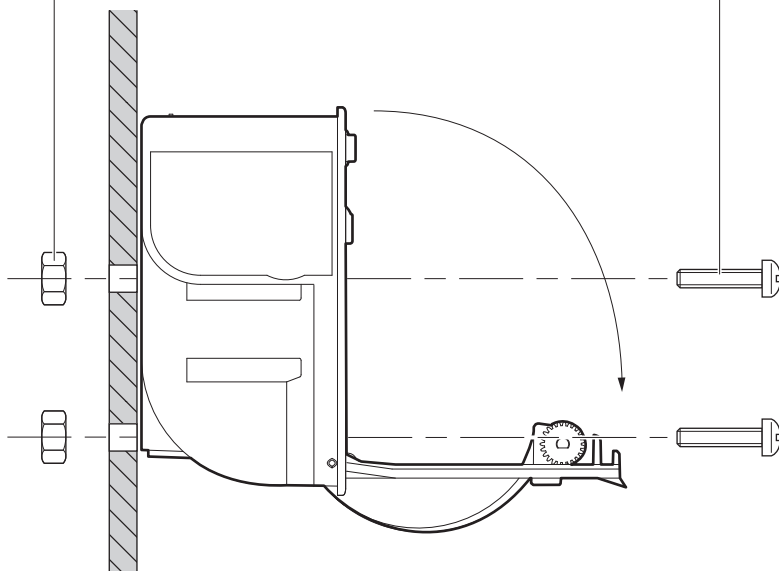
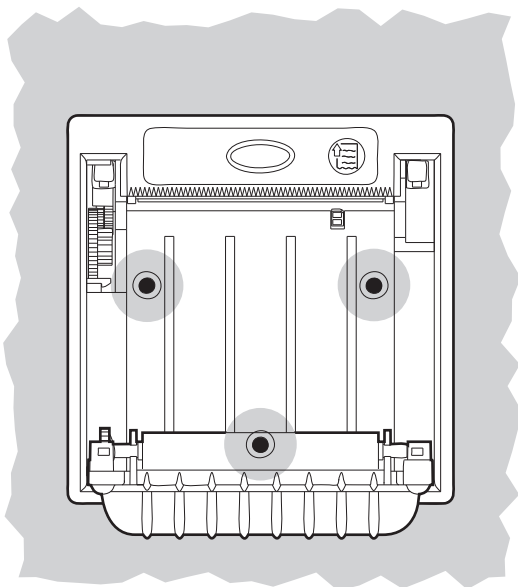

The panel must provide a drilling complies with the measures shown in the following page.

Drilling for mounting on panel with
SCHEME A

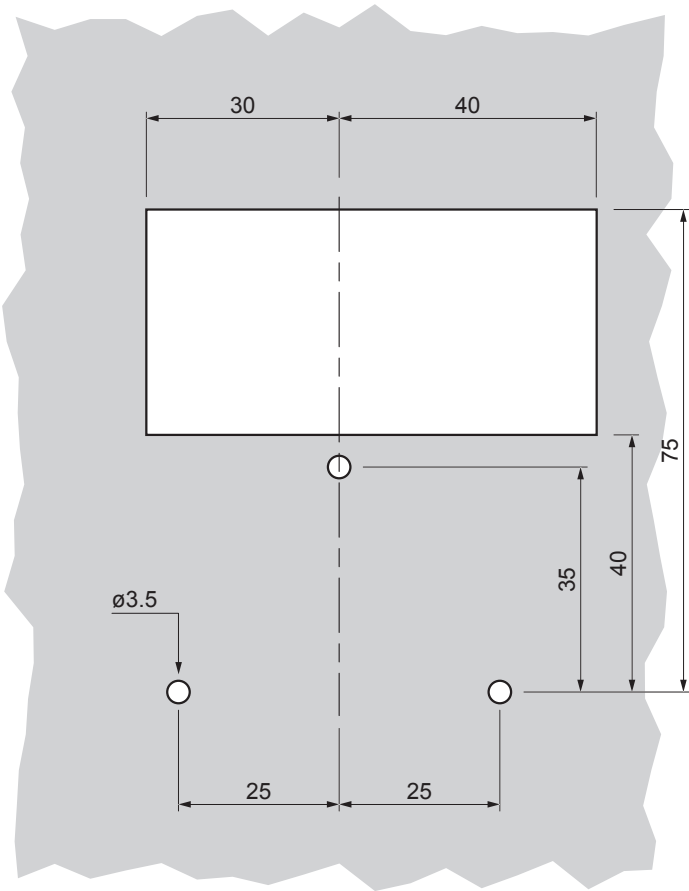

Drilling for mounting on panel with
SCHEME B

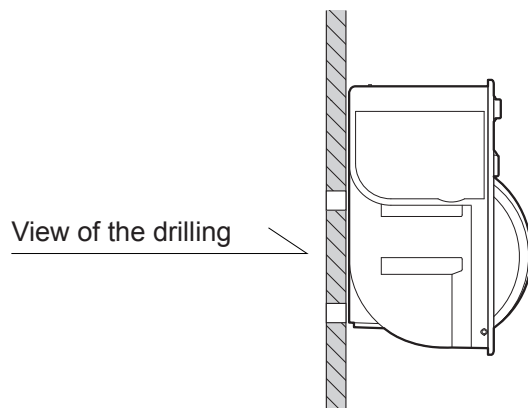
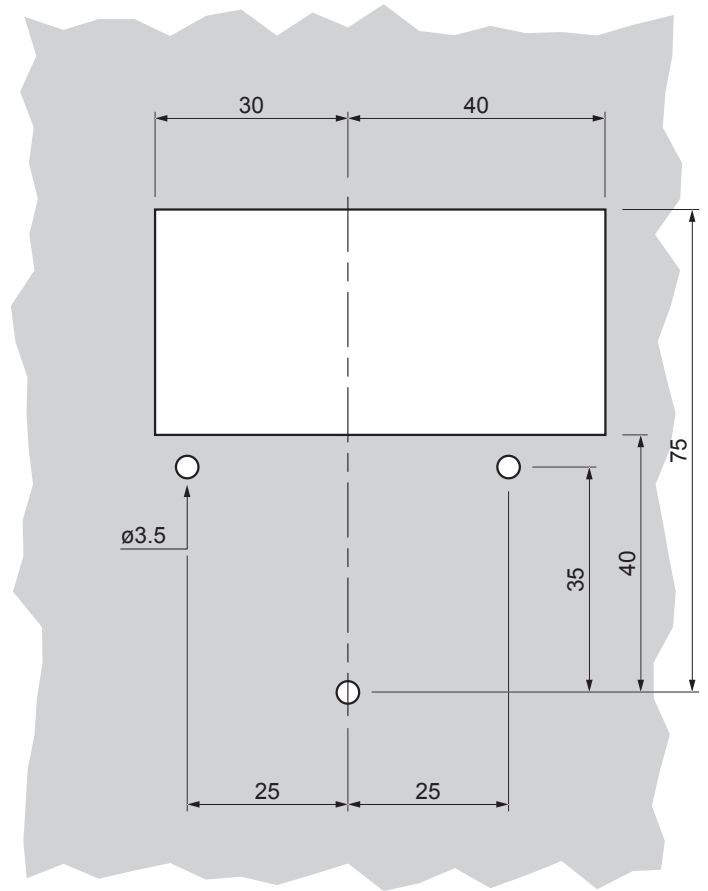

NOTE: All the dimensions shown in following figures are in millimetres.

3.3 Collections

The following figure shows the possible connections for the device.

ATTENTION:

In some using conditions, we recommend the installation of a ferrite core on the power supply cable.

NOTE:

If RS232 and USB connectors are inserted, communication port is USB.

Standard model 4±7.5 Vdc

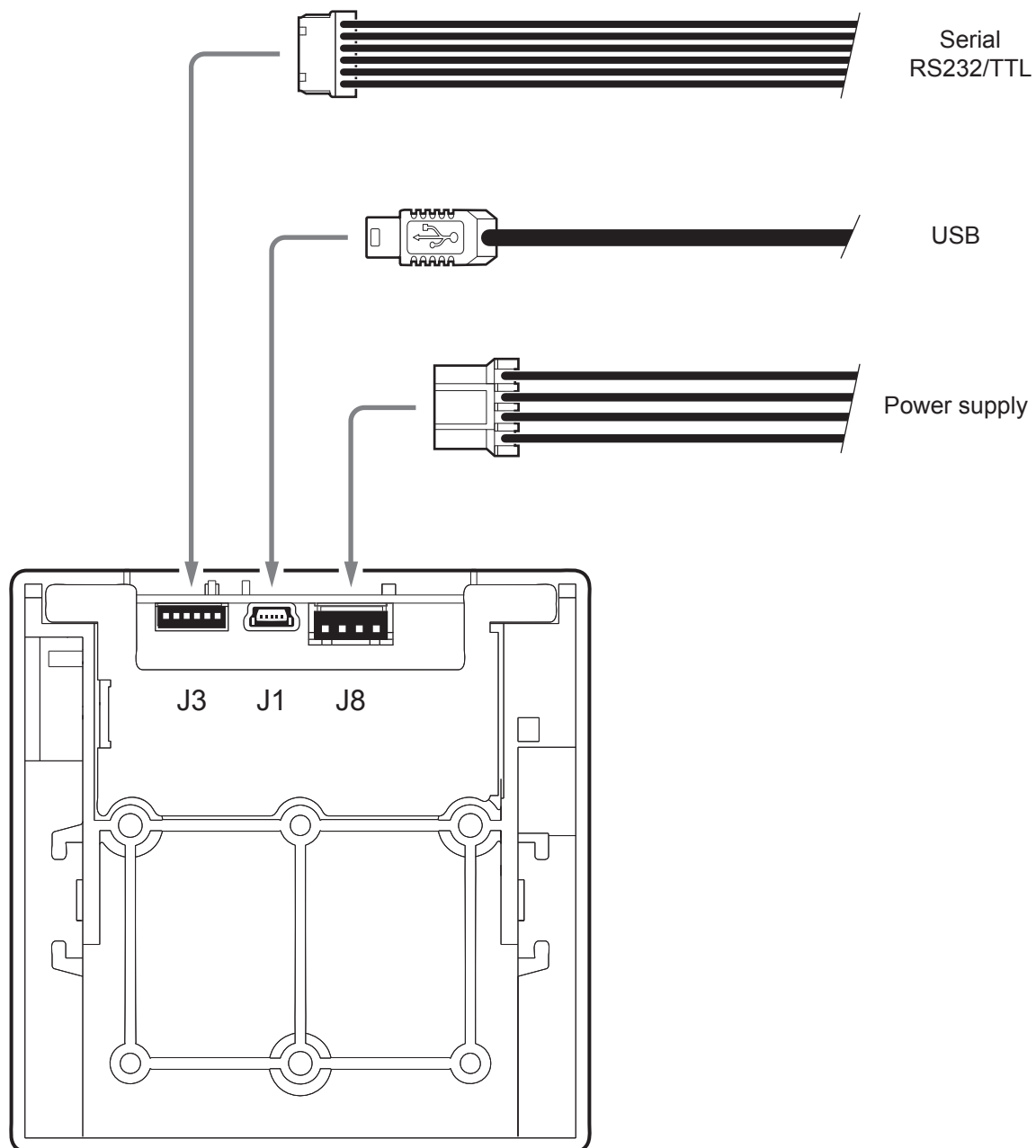

Model with the 8÷42 Vdc extended range module plugged

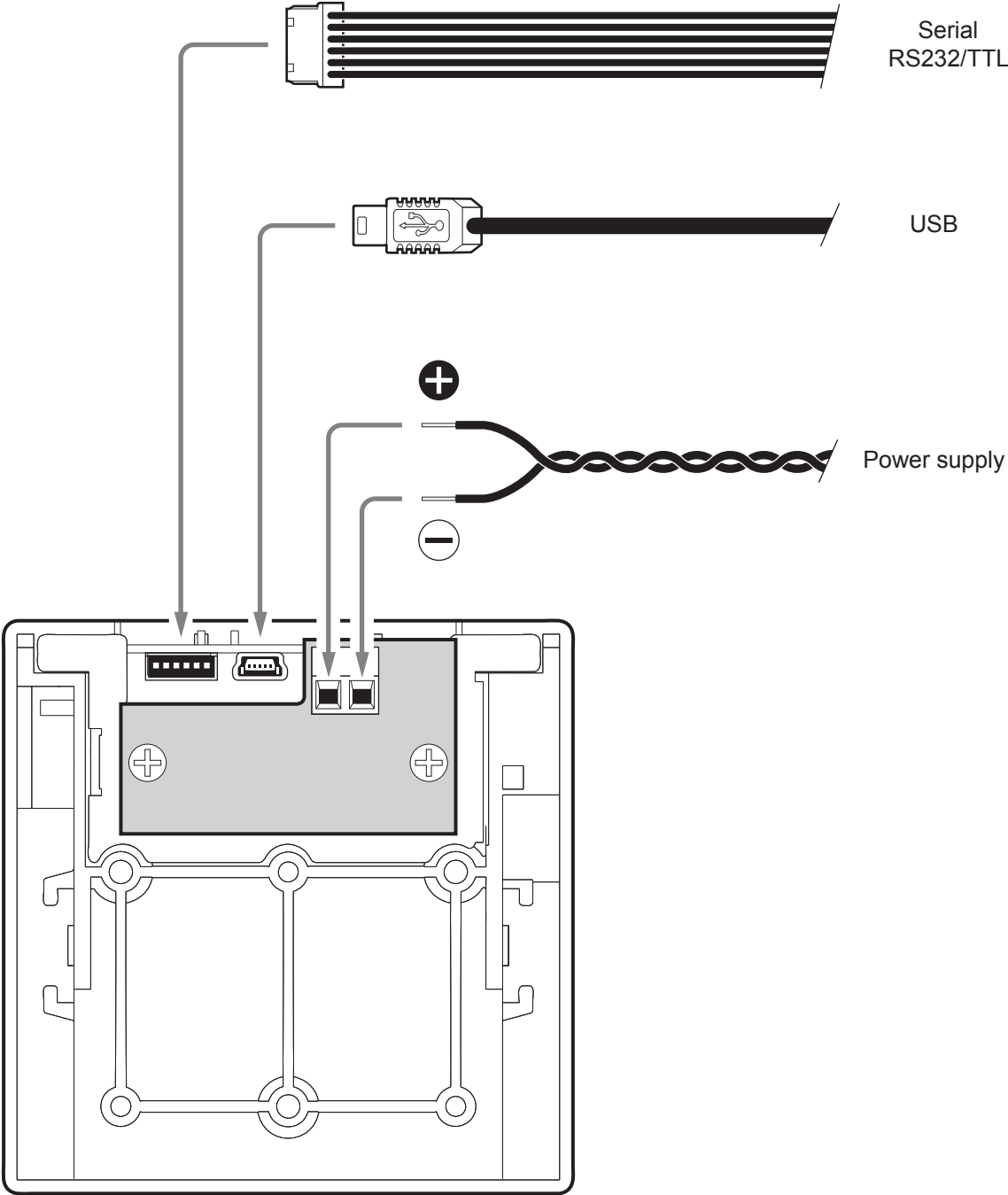

3.4 Pinout



POWER SUPPLY
JST male connector (S4B-PH-K-S)

J8	1	GND
	2	GND
	3	+VP
	4	+VCC

ATTENTION:
Respect power supply polarity.

NOTE: Power supply cable
The following figure shows the connector pinout of the power supply cable for the device:

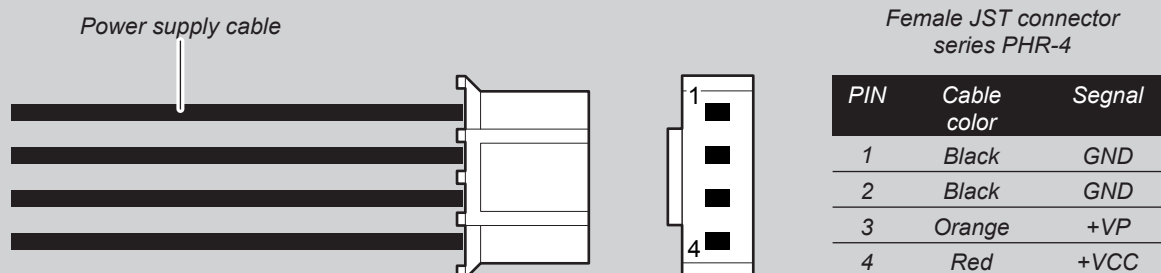

MINI USB INTERFACE
Female MINI USB type B connector

J1	1	VPLUG
	2	D0-
	3	D0+
	4	n.c.
	5	GND
	SH1	GND
	SH2	GND
	SH3	GND
	SH4	GND



RS232/TTL SERIAL INTERFACE

Molex male connector 53048-0610 series (90°)

J3	1	RT	
	2	TX	During transmission, oscillates between "0" and "1" depending on data
	3	RX	During reception, oscillates between "0" and "1" depending on data
	4	GND	
	5	EXT-FEED	
	6	EXT-LED	

NOTES:

Given the presence of the RS232 standard, logic value "0" corresponds to a voltage level of between +3Vdc and +15Vdc and logic value "1" corresponds to a voltage level of between -3Vdc and -15Vdc.

Device > PC connection

The following pictures shows an example of connections between the printer and a personal computer using a 9 pin RS232 serial connectors:

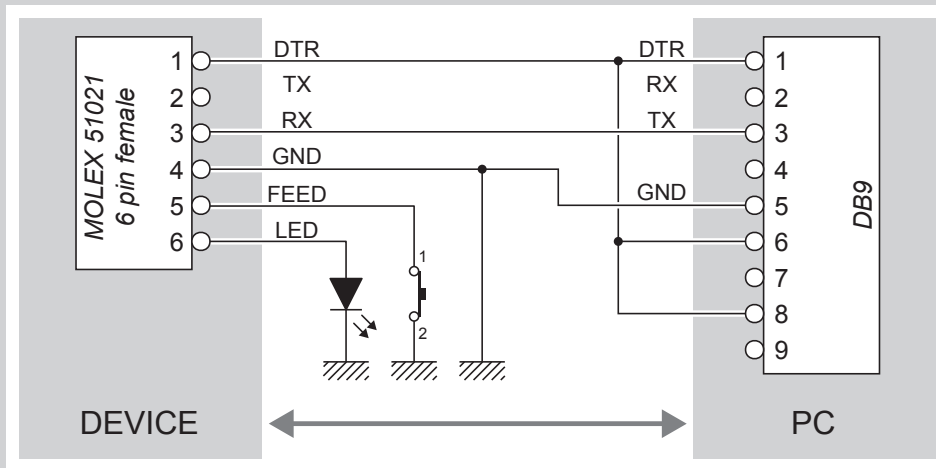

When use a serial cable, we recommend the installation of a ferrite core on the power supply cable.

3.5 Serial port setting

To set the serial port of the device, slide the switch shown in figure in the correct position:

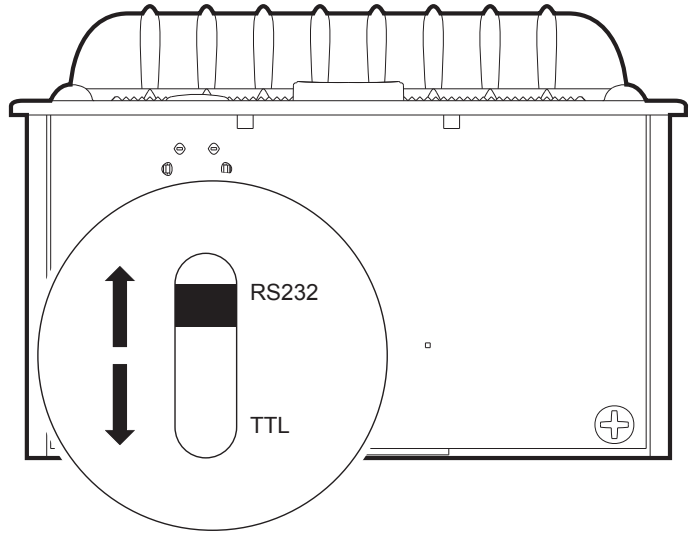

In the serial protocol, the signals which distinguish the communication are TD, RD, and RTS if the RTS/CTS protocol has been selected while, if the XON/XOFF protocol has been selected, the signals are TD and RD.

Transmission format



Notes:

- (1) Bit 7 is present if only in the printer set-up is enabled 8 bit/char as data length.
- (2) Parity Bit is preset if only in the printer set-up the parity is enabled.

RTS/CTS Protocol

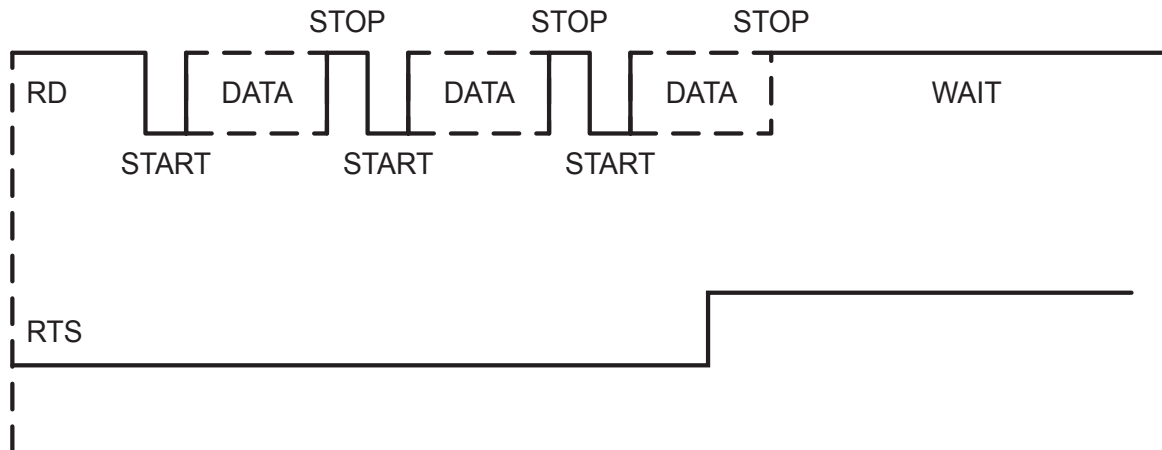

XON/XOFF protocol

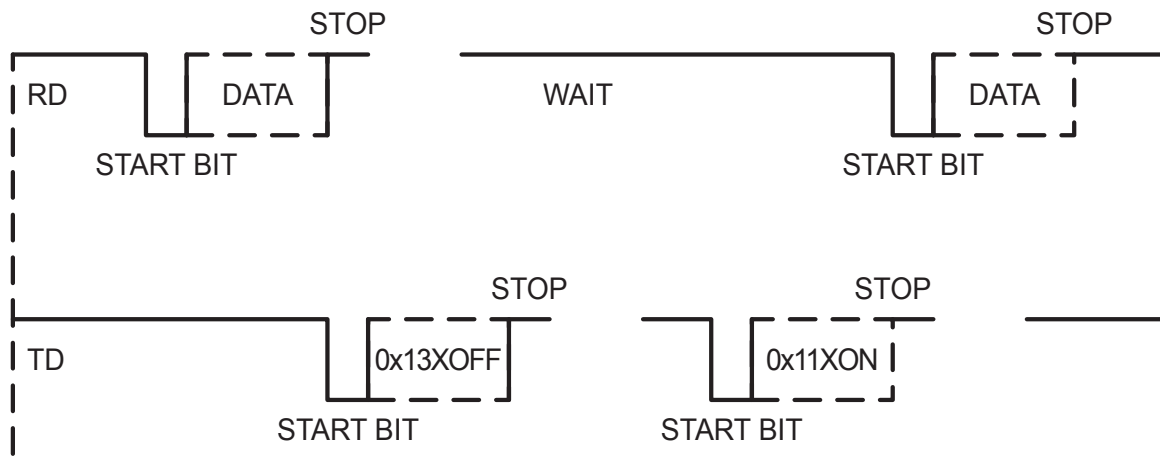

3.6 Driver and SDK

The drivers are available for the following operating system:

OPERATING SYSTEM	DESCRIPTION	INSTALLATION PROCEDURE
Windows	Driver per Windows XP	From the START menu, press Run and type-in the path where the SW was saved on your PC, then click OK. Follow the instructions that appear on the screen to install the driver.
	Driver per Windows VISTA (32/64bit)	
	Driver per Windows 7 (32/64bit)	
	Driver per Windows 8 (32/64bit)	
Linux		Follow the instruction get back on the README.TXT file. You can find it in the software package downloaded in advance.
Android	Library for CustomAndroidAPI	Extract the zipped folder to the destination path desired. Follow the instructions present in the software package that you downloaded on how to install and use the library.

NOTA:

All drivers can be found in the DOWNLOAD section of the web site www.custom.biz.

4 OPERATION

4.1 Loading the paper roll

To change the paper proceed as follows. At every change of paper, check inside the printer to locate and remove any scraps of paper.

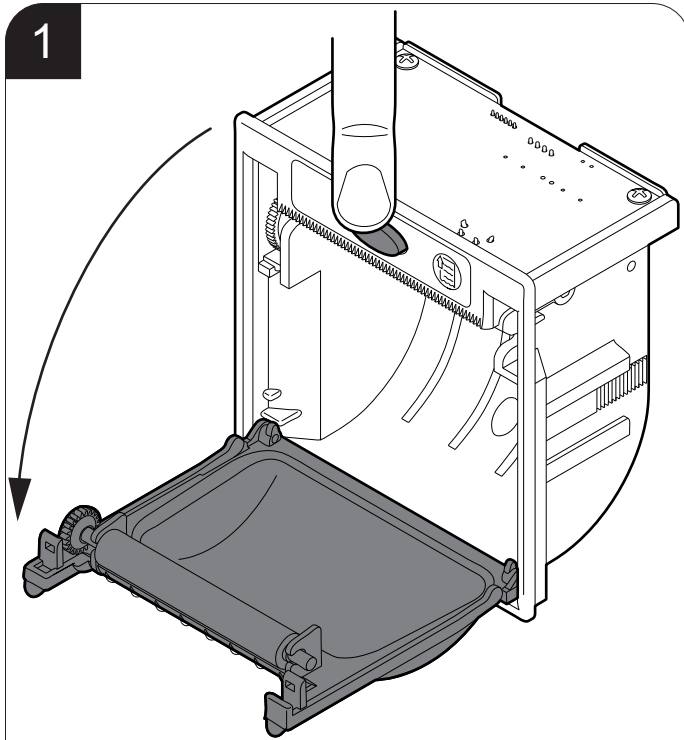

Open the printer cover

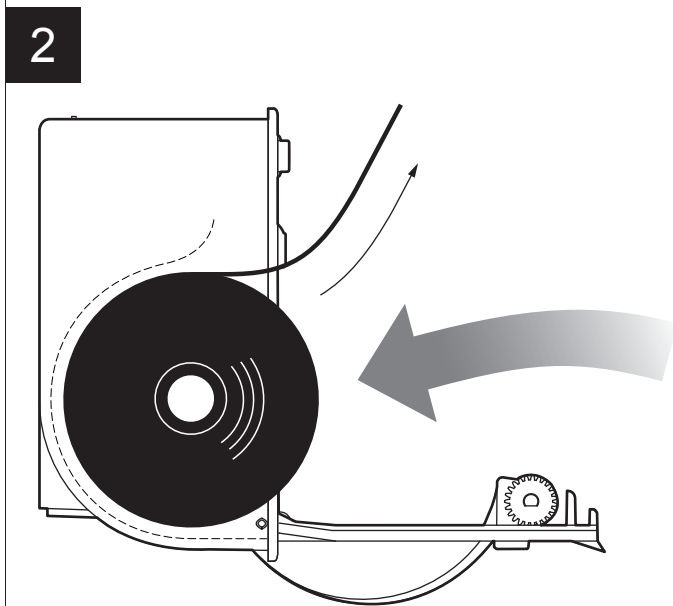

Place the roll in the paper compartment and pull out the paper for a few centimetres

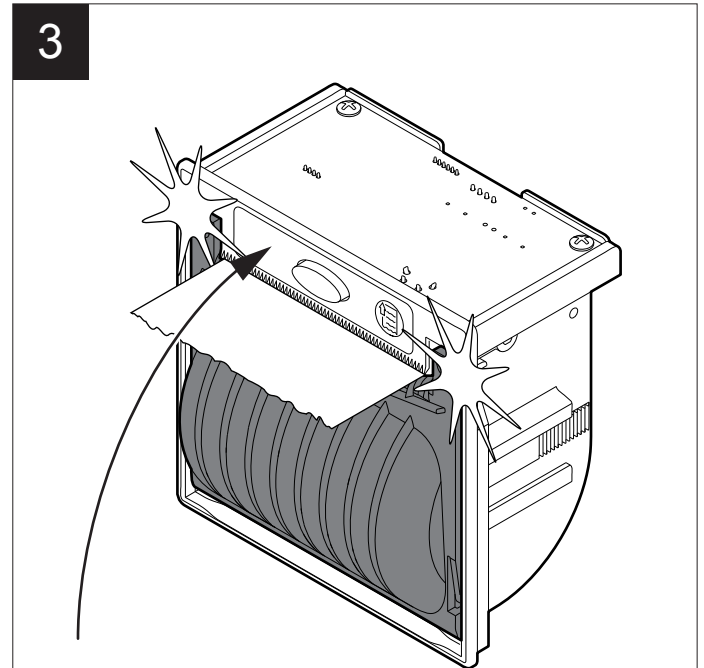

Close the printer cover

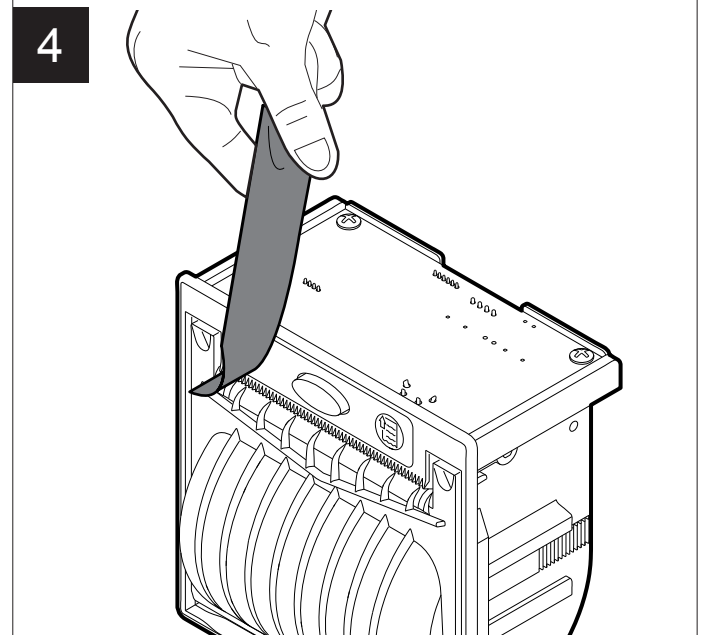

Remove the excess paper

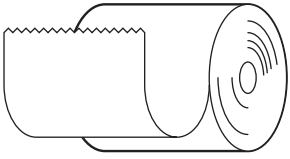

Thermal paper

Print density

- √ -50%
- √ -37%
- √ -25%
- √ -12%
- √ 0
- √ +12%
- √ +25%
- √ +37%
- √ +50%

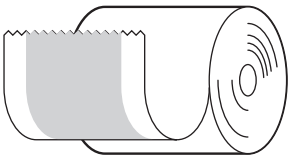

Linerless thermal paper

Print density

- √ Linerless

When using normal thermal paper, set the parameter "Print density" on one of the values between -50% and +50% (see chap. 5).

When using linerless thermal paper, set the parameter "Print density" on "linerless" (see chap. 5).

5 CONFIGURATION

5.1 Configuration mode

To enter the configuration mode and print a SETUP report with the operating parameters of the printer, proceed as follows.

1

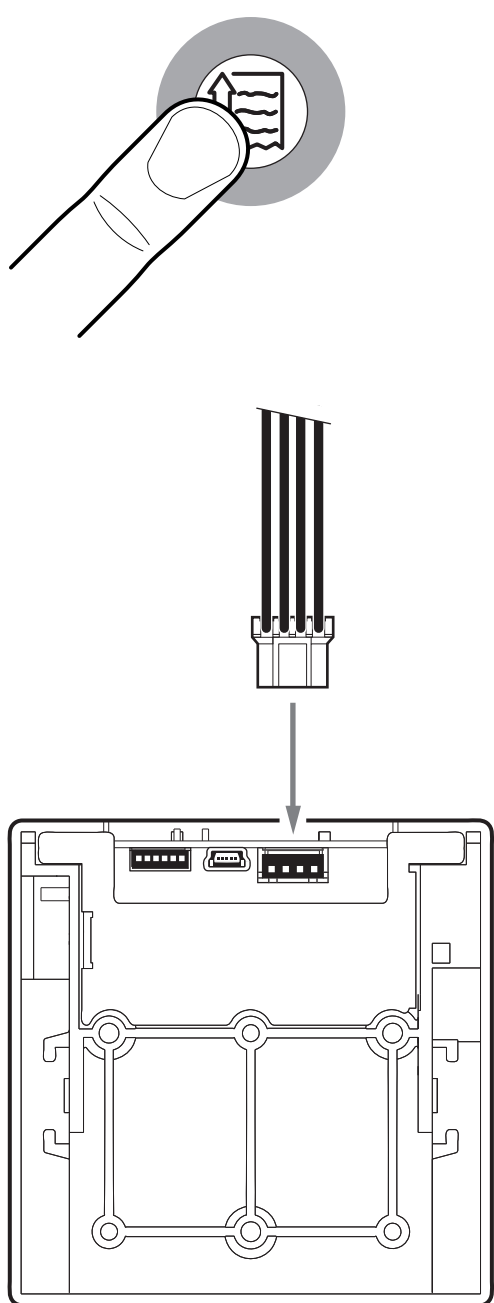

While pressing the FEED key, switch on the printer by inserting the power supply cable

2

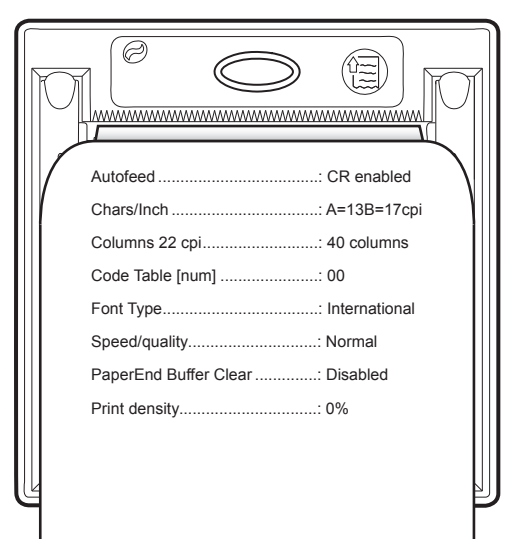

Autofeed	CR enabled
Chars/Inch	A=13B=17dpi
Columns 22 cpi.....	40 columns
Code Table [num]	00
Font Type.....	International
Speed/quality.....	Normal
PaperEnd Buffer Clear	Disabled
Print density.....	0%

The printer prints the report with parameters for printer settings

3

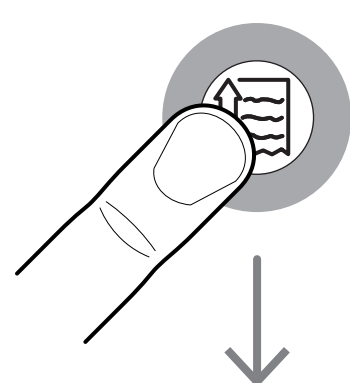

Enter printer setup

Press the FEED key to enter the configuration mode

5.2 Setup report

The following figure show the setup report of the printer. The shown values for parameters are sample values; for the list and the description of printer parameters see the following paragraphs.

<p><i>KEYS FUNCTIONS</i> {</p>	<p>[FAST PUSH] to skip Setup [PUSH] to enter Printer setup</p>
<p><i>PRINTER NAME and FIRMWARE MODULES RELEASE</i> {</p>	<p style="text-align: center;">PLUS2 printer</p> <p>SCODE <code> - rel 1.00 FCODE <code> - rel 1.00</p>
<p><i>DEVICE STATUS</i> {</p>	<p style="text-align: center;">PRINTER SETTINGS</p> <p>PRINTER TYPEPLUS2 PRINTING HEAD TYPEE48-CE INTERFACERS232 PROGRAM MEMORY TEST.....OK DYNAMIC RAM TEST.....OK EEPROM TEST.....OK HEAD VOLTAGE [V] = 04.84 HEAD TEMPERATURE [°C] = 25 POWER ON COUNTER = 4 PAPER PRINTED [cm] = 40</p>
<p><i>PRINTER PARAMETERS</i> {</p>	<p>Printer Emulation : PLUS RS232 Baud Rate : 9600 bps RS232 Data Length : 8 bits/chr RS232 Parity : None RS232 Handshaking : Xon/Xoff Busy Condition : RxFull USB Address Number : 0 Print Mode : Normal Autofeed : CR Enabled Chars / inch : A=13 B=17 cpi Columns 22 cpi..... : 40 columns Code Table [num] : 00 Font Type..... : International Speed / Quality..... : Normal PaperEnd Buffer Clear : Disabled Print Density..... : 0%</p>

5.3 Printer status

The printer operating status is indicated in the configuration print-out in which, next to the name of the components displayed, the following information is given:

PRINTER TYPE	<i>device model</i>
PRINTING HEAD TYPE	<i>print head model</i>
INTERFACE	<i>interface present</i>
PROGRAM MEMORY TEST	<i>OK appears if functioning and NOT OK if faulty</i>
DYNAMIC RAM TEST	<i>OK appears if functioning and NOT OK if faulty</i>
EEPROM TEST	<i>OK appears if functioning and NOT OK if faulty</i>
HEAD VOLTAGE	<i>voltage of the head</i>
HEAD TEMPERATURE	<i>temperature of the head</i>
POWER ON COUNTER	<i>number of power-ups made</i>
PAPER PRINTED	<i>centimetres of paper printed</i>

5.4 Printer parameters

This printer allows the configuration of the parameters listed in the following table. The parameters marked with the symbol ^D are the default values. Settings remain active even after the printer has been turned off and they are stored in non-volatile memory.

PRINTER EMULATION	<p><i>Available emulations for the device:</i></p> <p><i>PLUS^D</i> <i>ESC/POS™</i></p>									
RS232 BAUD RATE	<p><i>Communication speed of the serial interface:</i></p> <table> <tbody> <tr> <td>115200</td> <td>19200</td> <td>2400</td> </tr> <tr> <td>57600</td> <td>9600^D</td> <td>1200</td> </tr> <tr> <td>38400</td> <td>4800</td> <td></td> </tr> </tbody> </table> <p>NOTE: Parameter valid only with serial interface.</p>	115200	19200	2400	57600	9600 ^D	1200	38400	4800	
115200	19200	2400								
57600	9600 ^D	1200								
38400	4800									
RS232 DATA LENGTH	<p><i>Number of bit used for characters encoding:</i></p> <p><i>7 bits/car</i> <i>8 bits/car^D</i></p> <p>NOTE: Parameter valid only with serial interface.</p>									
RS232 PARITY	<p><i>Bit for the parity control of the serial interface:</i></p> <p><i>None^D = parity bit omitted</i> <i>Even = even value for parity bit</i> <i>Odd = odd value for parity bit</i></p> <p>NOTE: Parameter valid only with serial interface.</p>									
RS232 HANDSHAKING	<p><i>Handshaking:</i></p> <p><i>XON/XOFF^D = software flow control</i> <i>Hardware = hardware flow control (CTS/RTS)</i></p> <p>NOTES: Parameter valid only with serial interface.</p> <p>When the receive buffer is full, if handshaking is set to XON/XOFF, the printer sends the XOFF (0x13) on the serial port. When the receive buffer has cleared once again, if handshaking is set to XON/XOFF, the printer sends the XON (0x11) on the serial port.</p>									
BUSY CONDITION	<p><i>Activation mode for Busy signal:</i></p> <p><i>OffLine/ RXFull = Busy signal is activated when the printer is both in OffLine status and the buffer is full</i> <i>RXFull^D = Busy signal is activated when the buffer is full</i></p> <p>NOTE: Parameter valid only with serial interface.</p>									

USB ADDRESS NUMBER *Numerical address code for the univocal identification of the USB device (in case of more than a USB device connected with the same PC):*

0^D 3 6 9
1 4 7
2 5 8

PRINT MODE *Printing mode:*

Normal^D = enables printing in normal writing way
Reverse = enables printing rotated 180 degrees

AUTOFEED *Setting of the Carriage Return character:*

CR disabled = Carriage Return disabled
CR enabled^D = Carriage Return enabled

CHARS / INCH *Font selection:*

A = 13 cpi, B = 17 cpi^D
A = 17 cpi, B = 22 cpi

NOTES:
CPI = Characters Per Inch

COLUMNS 22 CPI *Number of columns to use when the 17x22 cpi font is in use (see parameter CHARS / INCH):*

40 columns^D
42 columns

NOTES:
The parameter is printed only with PLUS emulation enabled.
To modify the parameter, set the PLUS emulation (see parameter PRINTER EMULATION) and the 17x22cpi font (see parameter CHARS / INCH):

CODE TABLE [num] *Identifier number of the character code table to use.*
The numeric value of the identifier is made up with the following two parameters for the setting of two digits for the tens and the units:

Setting the digit for tens:

CODE TABLE [num x 10] 0^D 2 4
1 3 5

Setting the digit for units:

CODE TABLE [num x 1] 0^D 2 4 6 8
1 3 5 7 9

NOTES:
See the paragraph 7.6 to learn about the character tables corresponding to the identification numbers set with this parameter.

The character tables set with this parameter are the same set with the command 0x1B 0x74 (refer to the Commands Manual of the device).

FONT TYPE

Setting of the font type:

International^D = Enables the use of the 256-characters font tables
Chinese GB18030 = Enables the use of the chinese extended font GB18030-2000
Korean PC949 = Enables the use of the korean font PC949

NOTE: When the "INTERNATIONAL" font type is enabled, must be selected the desired character code table (parameter "CODE TABLE"). When the chinese or korean font is enabled, the selection of the character code table is suspended (par. "CODE TABLE").

SPEED / QUALITY

Setting of printing speed and printing quality:

Normal^D
High Quality

PAPEREND BUFFER CLEAR

Cleaning mode of the data in receive buffer, if the printing is stopped due to lack of paper:

Disabled^D = The data remain in the receive buffer. When the paper runs out, the printer keeps the remaining data in the receive buffer and prints the remaining portion of the ticket after that the new paper is loaded.
Enabled = When the paper runs out, all data in the receive buffer are deleted.

PRINT DENSITY

Adjusting the printing density:

<i>-50%</i>	<i>-12%</i>	<i>+25%</i>	<i>Linerless</i>
<i>-37%</i>	<i>0^D</i>	<i>+37%</i>	
<i>-25%</i>	<i>+12%</i>	<i>+50%</i>	

5.5 Hexadecimal dump

This function is used for the diagnosis of the characters received from the communications port. Characters are printed as hexadecimal code and the corresponding ASCII code (see below). Each line is preceded by a counter in hexadecimal that indicates the number of bytes received.

During the startup, if you hold down the FEED key, the printer enters the self-test routine and print the setup report. The printer remains in standby until a key is pressed or characters are received through the communication port (Hexadecimal Dump mode). For each character sent, the receipt contain an indication of the hexadecimal and ASCII values (if the characters are underlined, the receive buffer is full). Shown below is an example of a Hexadecimal Dump:

HEXADECIMAL DUMP									
31	32	33	34	35	...	12345	...		
39	30	31	32	33	...	90123	...		
37	38	39	75	69	...	789ui	...		
68	6B	6A	73	64	...	hkjsd	...		
73	64	66	6B	6A	...	sdfkj	...		
66	73	64	66	6B	...	fsdfk	...		
65	69	6F	79	75	...	eioyu	...		
6F	72	69	75	77	...	oriuw	...		
6F	75	77	65	72	...	ouwer	...		
77	65	72	69	6F	...	werio	...		
72	69	6F	75	77	...	riouw	...		
6B	6C	73	64	66	...	kl sdf	...		
64	66	6B	73	64	...	dfksd	...		
73	64	66	6B	6A	...	sdfkj	...		
66	6B	F2	6A	73	...	fk>j	...		
6A	6B	6C	68			jklh			

6 MAINTENANCE

6.1 Planning of cleaning operations

The regular cleaning of the device keeps the print quality and extends its life. The following table shows the recommended planning for the cleaning operations.

EVERY PAPER CHANGE	
Printhead	Use isopropyl alcohol
Rollers	Use isopropyl alcohol
EVERY 5 PAPER CHANGES	
Paper path	Use compressed air
Sensors	Use compressed air
EVERY 6 MONTHS OR AS NEEDED	
Printer case	Use compressed air or a soft cloth

For specific procedures, see the following pages.

NOTE:

If you use the device in dusty environments, you must reduce the intervals between the cleaning operations.

6.2 Cleaning

For periodic cleaning of the printer, see the instructions below

Sensors

1

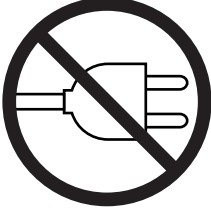

Disconnect the power supply cable and open the printer cover (see par. 4.1)

2

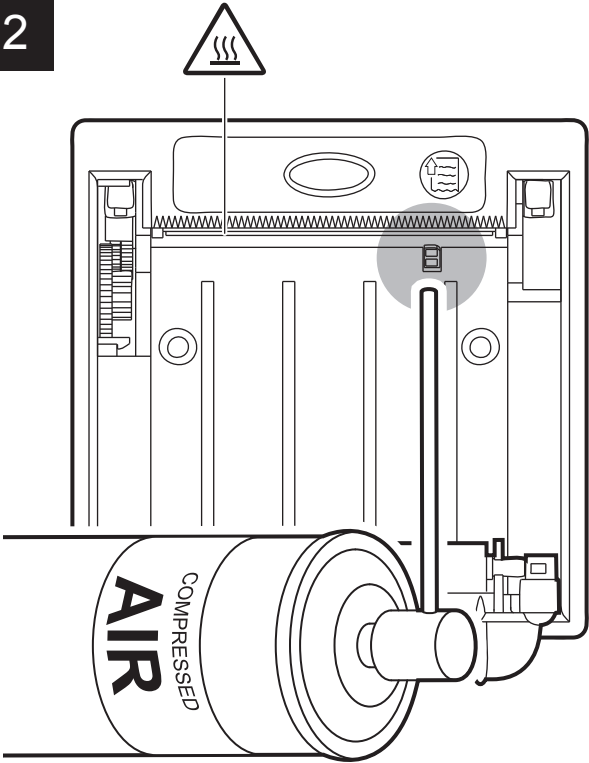

Clean the printer sensor by using compressed air

ATTENTION:
Do not use alcohol, solvents, or hard brushes.
Do not let water or other liquids get inside the machine.



Icons showing: a brush, a bottle of alcohol/solvent, a spray nozzle, and a power button with 'ON' text.

Case

1

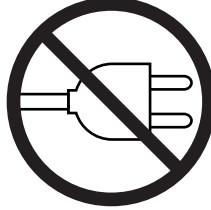

Disconnect the power supply cable

2

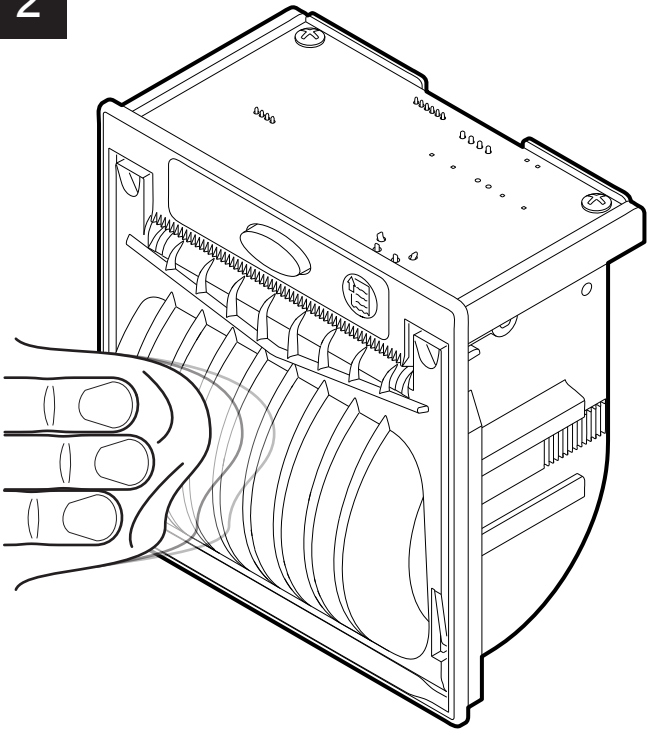

To clean the machine, use compressed air or a soft cloth.

ATTENTION:
Do not use alcohol, solvents, or hard brushes.
Do not let water or other liquids get inside the machine.



Icons showing: a brush, a bottle of alcohol/solvent, a spray nozzle, and a power button with 'ON' text.

Paper path

1

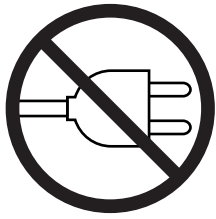

Disconnect the power supply cable and open the printer cover (see par. 4.1)

2

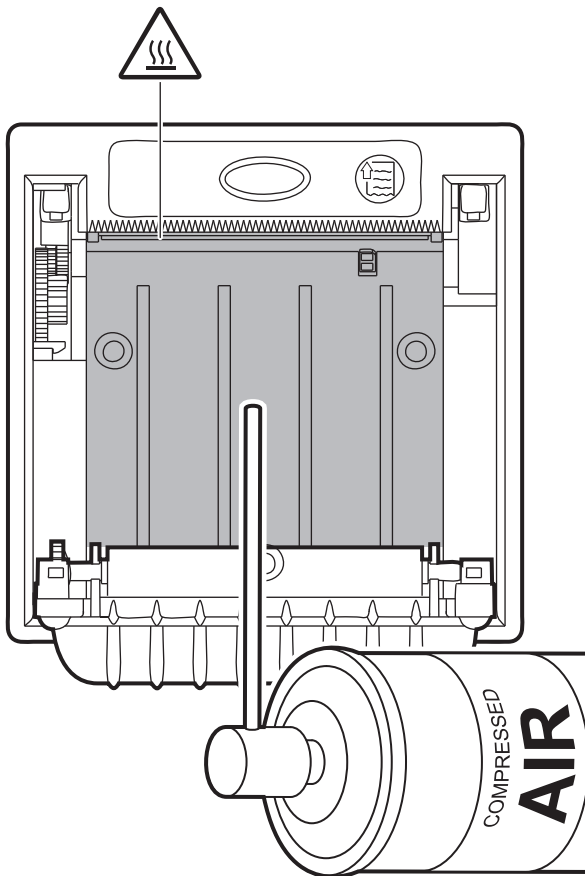

Clean the area involved in the passage of paper by using compressed air.

ATTENTION:

Do not use alcohol, solvents, or hard brushes.
Do not let water or other liquids get inside the machine.

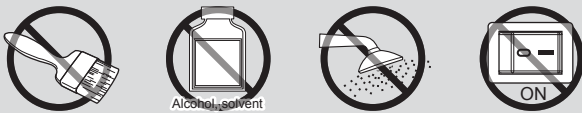

Print head

1

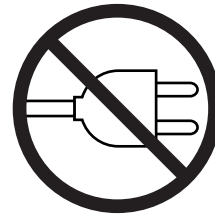

Disconnect the power supply cable and open the printer cover (see par. 4.1)

2

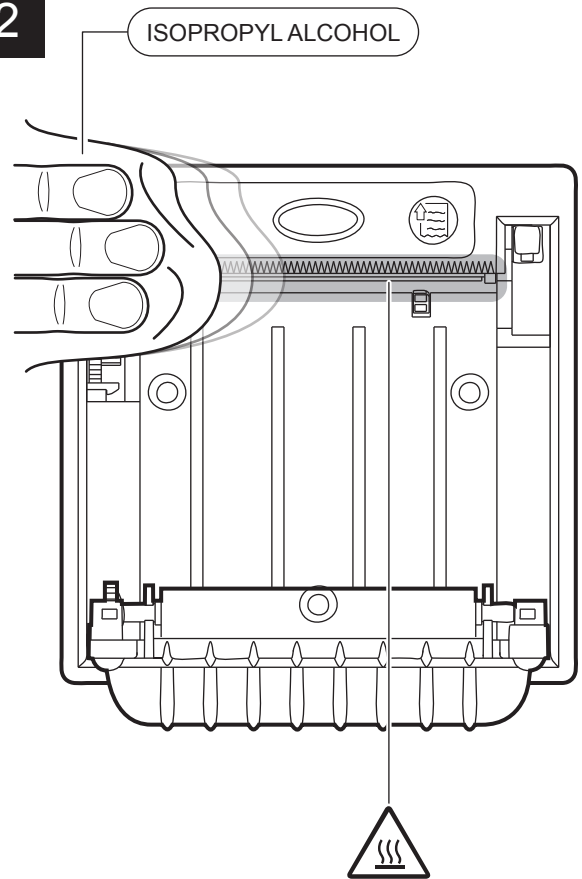

Clean the printing head by using a non-abrasive cloth moistened with isopropyl.

ATTENTION:

Do not use solvents, or hard brushes.
Do not let water or other liquids get inside the machine.



Printing roller

1

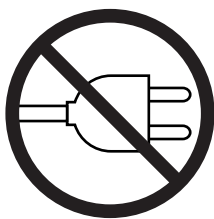

Disconnect the power supply cable and open the printer cover (see par. 4.1)

2

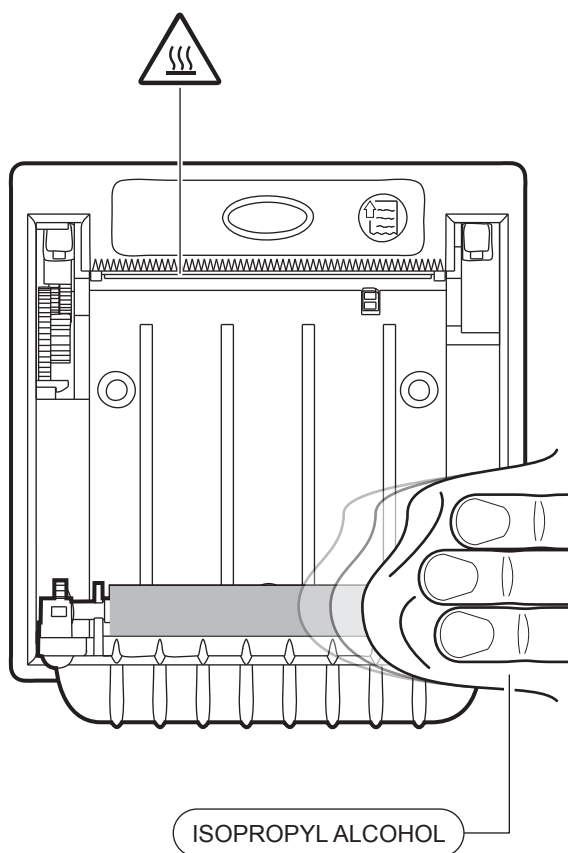

Clean the printing roll by using a non-abrasive cloth moistened with isopropyl.

ATTENTION:

Do not use solvents, or hard brushes.
Do not let water or other liquids get inside the machine.



6.3 Upgrade firmware

WARNING: During communication between PC/printer for the firmware update it is strictly forbidden to disconnect the communication cable or to remove the power supply of the devices not to endanger the proper functioning of the printer.

NOTES:

The latest firmware of the printer is available in the download area of the web site www.custom.biz

Install on the PC used for printer upgrading the UPG-CEPRN software available in the download area of the web site www.custom.biz.

UPDATE VIA SERIAL INTERFACE

Proceed as follows:

1. Write down the product code (14 digits) printed on the product label (see par. 2.3).
2. Go to the web site www.custom.biz and download the appropriate firmware release from the DOWNLOAD area.
3. Print the SETUP report (see chapter 5).
4. Switch OFF the printer.
5. Connect the printer to the PC using a serial cable (see paragraph 3.3).
6. Switch ON the printer.
7. Launch the software UPGCEPRN.
8. Select the update file .PSW location:

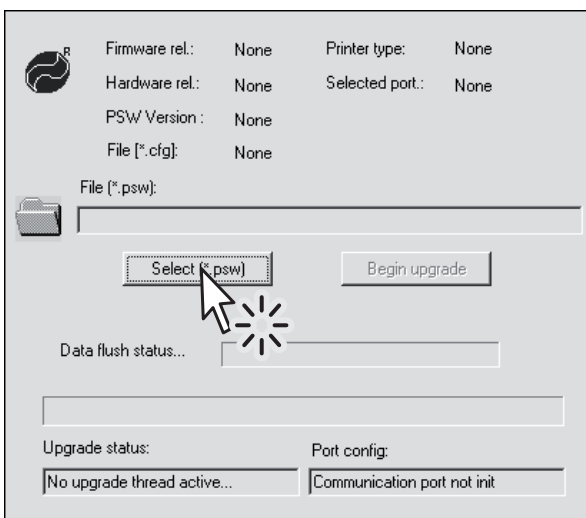

9. Select the serial communication port (ex. COM1):

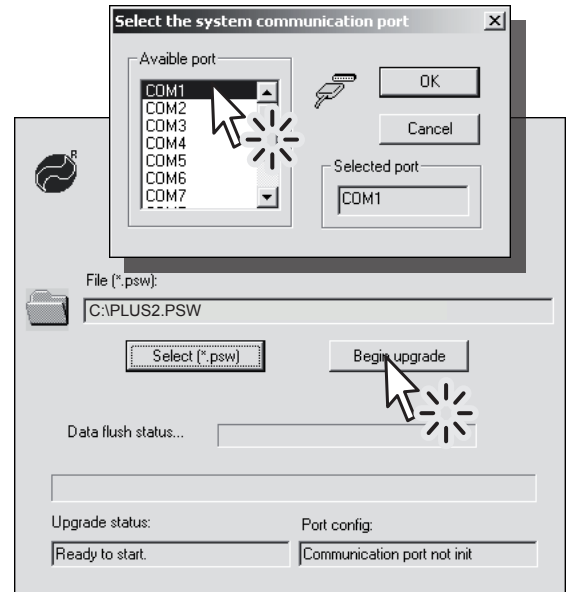

10. Detecting and setting of the parameters necessary for serial communication are performed automatically and then updating begins.
11. After a few minutes a message on the screen warns that the update is completed.

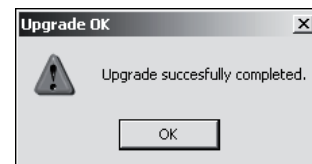

12. Print a new SETUP report to verify the new firmware release (see chapter 5).

UPDATE VIA USB INTERFACE

ATTENTION:

Only during the firmware update, the connection between PC and printer must be direct, without the use of HUB devices.

Only during the firmware update, do not connect or disconnect other USB devices.

NOTE: For communication via USB you must install on PC the printer driver available in the download area of the web site www.custom.biz.

Proceed as follows:

1. Write down the product code (14 digits) printed on the product label (see par. 2.3).
2. Go to the web site www.custom.biz and download the appropriate firmware release from the DOWNLOAD area.
3. Print the SETUP report (see chapter 5).
4. Switch OFF the printer.
5. Connect the printer to the PC using a USB cable (see paragraph 3.3).
6. Switch ON the printer.
7. Launch the software UPGCEPRN.
8. Select the update file .PSW location:

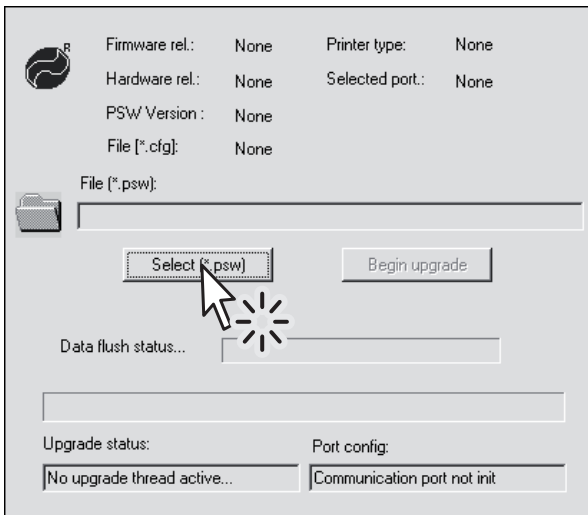

9. Select item USB and then select the USB device among those proposed (ex. PLUS2):

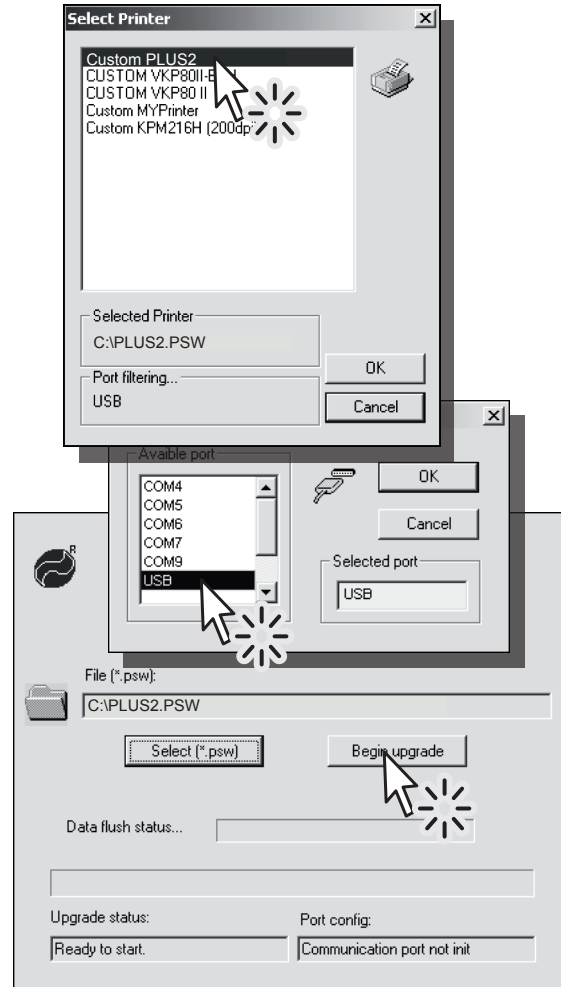

10. After a few minutes a message on the screen warns that the update is completed.

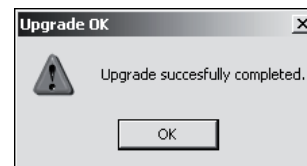

11. Print a new SETUP report to verify the new firmware release (see chapter 5).

7 SPECIFICATION

7.1 Hardware specifications

GENERAL	
Sensors	Head temperature, paper presence
Emulations	PLUS ESC/POS™
Printing driver	Windows XP, VISTA (32/64bit), Windows 7 (32/64bit), Windows 8 (32/64bit) Linux, Android
INTERFACES	
USB port	12 Mbit/sec (USB 2.0 full speed)
RS232/TTL serial port	from 1200 to 115200 bps
MEMORIES	
Receive buffer	16 Kbytes
Flash memory	4 Mbytes (+768Kbytes internal)
RAM memory	128 Kbytes
Graphic memory	Logos dynamic management (max 32 Kbytes graphic memory)
PRINTER	
Resolution	203 dpi (8 dot/mm)
Printing method	Thermal, fixed head
Printing width	48 mm
Printing mode	Normal, 90°, 180°, 270°
Printing format	Height/Width from 1 to 8, bold, reverse, underlined, italic
Character fonts	54 character code tables (see par. 7.6) Extended chinese GB18030-2000 Korean PC949

Printable barcode	UPCA, UPCE, EAN13, EAN8, CODE39, ITF, CODABAR, CODE93, CODE128, CODE32, PDF417, QR CODE
-------------------	--

Printing speed ^{(1) (2)}	max. 50 mm/sec
-----------------------------------	----------------

PAPER

Type of paper	Thermal rolls, heat-sensitive side on outside of roll Linerless thermal rolls (see paragraph 7.5)
---------------	--

Paper width	57 mm ± 0,5 mm
-------------	----------------

Paper weight	from 55 g/m ² to 70 g/m ²
--------------	---

Paper thickness	from 63 µm to 85 µm
-----------------	---------------------

Recommended types of paper	KANZAN KF50 and KP460 MITSUBISHI PG5075
----------------------------	--

External roll diameter	max. 50 mm
------------------------	------------

External roll core diameter	12 mm (+ 1mm)
-----------------------------	---------------

Paper end	Not attached to roll core
-----------	---------------------------

Core type	Cardboard or plastic
-----------	----------------------

PRINTER ELECTRICAL SPECIFICATIONS

Power supply	
--------------	--

<i>standard model</i>	From 4 to 7.5 Vdc ±10% (optional external power supply)
-----------------------	---

<i>model with the extended range module plugged</i>	From 8 to 42 Vdc ±10% (optional external power supply)
---	--

Medium consumption ⁽²⁾	
-----------------------------------	--

<i>standard model</i>	1.25 A (4Vdc) 0.7 A (7.5Vdc)
-----------------------	---------------------------------

<i>model with the extended range module plugged</i>	0.21 A (8Vdc) 1 A (42Vdc)
---	------------------------------

Stand-by consumption	
----------------------	--

<i>standard model</i>	0.060 A
-----------------------	---------

*model with the extended range
module plugged*

0.060 A

ELECTRICAL SPECIFICATIONS POWER SUPPLY cod. 964GE010000003

Power supply voltage from 90 Vac to 264 Vac

Frequency from 50 Hz to 60 Hz

Current (output) 5 A

Power 25W

ENVIRONMENTAL CONDITIONS

Operating temperature from 0°C to +50°C

Relative humidity from 10% Rh to 85% Rh

Storage temperature from -20 °C to +70 °C

Storage relative humidity from 10% Rh to 90% Rh

NOTES:

- (1) : Respecting the regular schedule of cleaning for the device components.
- (2) : Referred to a standard CUSTOM receipt (L=10cm, Density = 12,5% dots on).

7.2 Character specifications in ESC/POS™ and PLUS emulation

Character set		3	
Character density	13 cpi	17 cpi	22 cpi
Number of columns	24	32	40/42
Chars / sec	360	480	640
Lines / sec	15	15	15
Characters (L x H mm)-Normal	2 x 3	1,5 x 3	1,125 x 3

7.3 Printer dimensions

Length	56.9 mm
Length with cover open	111 mm
Height	85 mm
Width	85 mm
Weight	141 g

NOTE:

Dimensions referred to devices without paper roll.
All the dimensions shown in following figures are in millimetres.

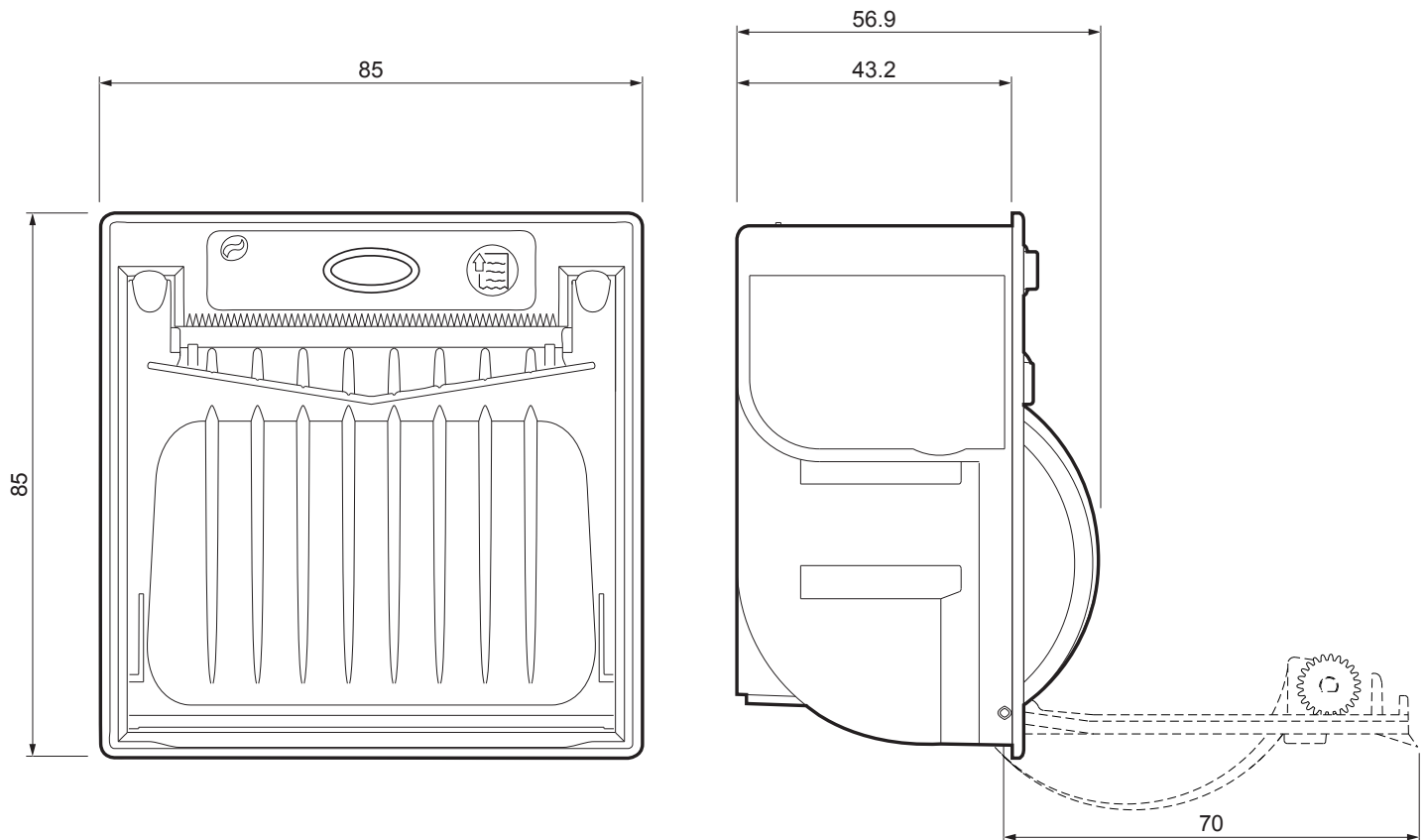

7.4 Power supply dimensions cod. 964GE010000003

Length	90.6 mm
Height	28,8 mm
Width	51 mm

NOTE: All the dimensions shown in following figures are in millimetres.

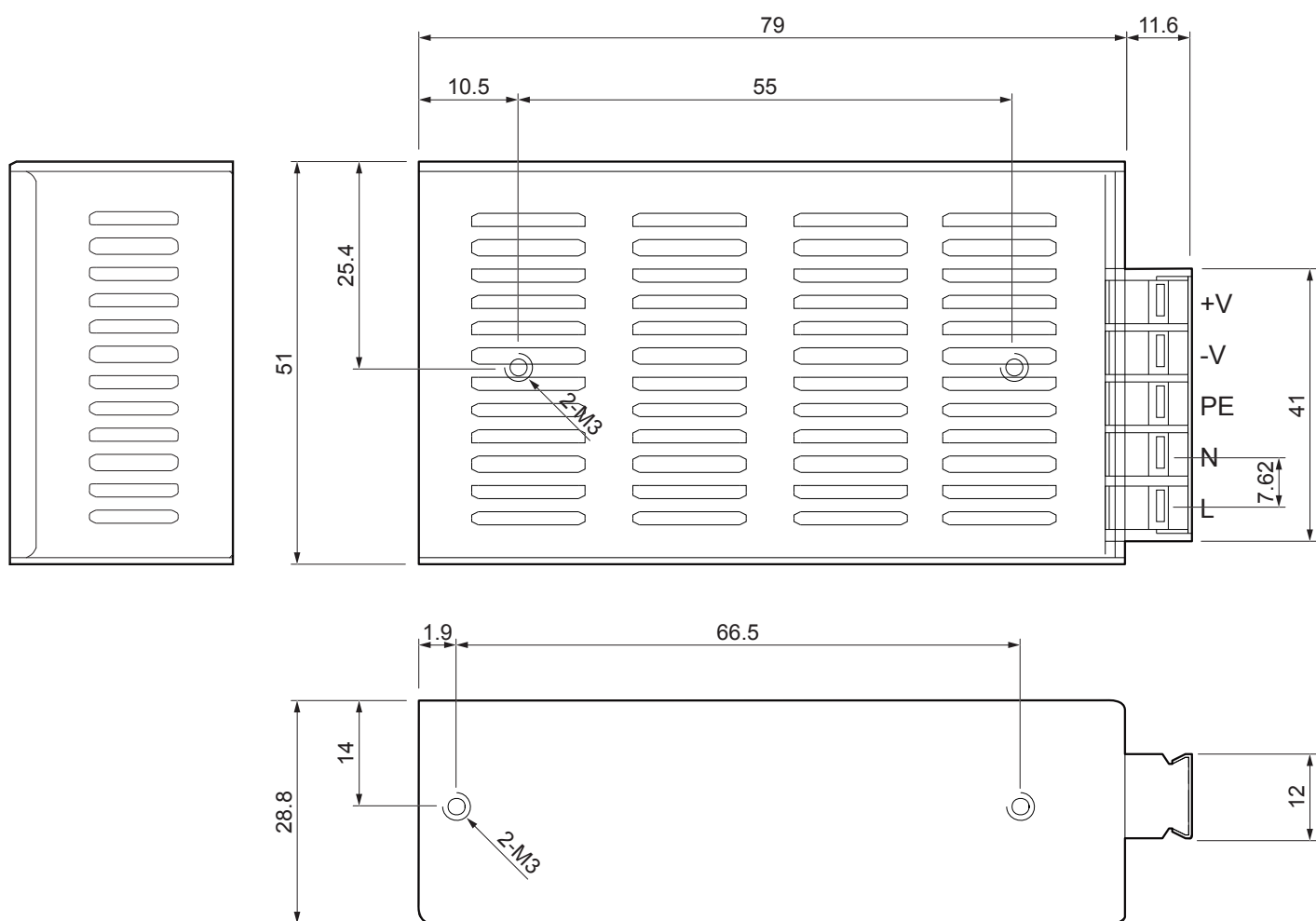

7.5 Paper specification

Linerless thermal paper

LINERLESS paper is a thermal paper with a self-adhesive layer without liner (on non-thermal side). For the better use with the printer the self-adhesive area must comply with the following dimensions:

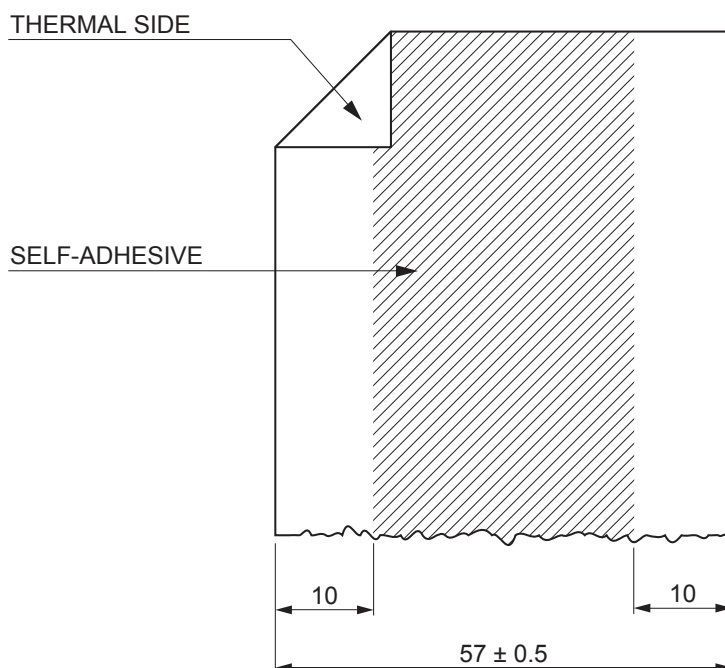

LINERLESS PAPER SPECIFICATIONS

Self-adhesive	Water based acrylic
Self-adhesive mass	Permanent 16 gr/mq ± 2 gr
Total thickness	93 μm ± 2 μm
Total weight	96 gr/mq ± 2 gr
Recommended temperature	
Stick	from +15°C to +40°C
Storage	from +10°C to +40°C
Resistance after stick	from -10°C to +50°C

WARNING:

Do not set "Printer Density" parameter on "Linerless" mode during the printer SETUP (see user manual) with common thermal paper.

In "Linerless" mode, if the printer is turned off a few hours, the first row of the press could be compressed, during the turning on. It is recommended to perform one or more paper FEED before printing.

7.6 Character sets in ESC/POS™ and PLUS emulation

The printer has 3 internal fonts with a width of 13, 17, 22 cpi, which can be associated with one of the coding tables stored on the device.

To know the coding tables actually stored on the device, print the font test (see par.2.4).

The selection of the font and the encoding table is done via command (see the commands manual of the device) or through the Setup procedure by properly setting the parameter “Chars / Inch”, “Code Table” and “Font Type” (see par. 5.4).

The following is the complete list of coding tables that can be installed on the device.

<CodeTable>	Character Tables	
0	PC437 - U.S.A., Standard Europe	
1	Katakana	
2	PC850 - Multilingual	
3	PC860 - Portuguese	
4	PC863 - Canadian/French	
5	PC865 - Nordic	
11	PC851 - Greek	on request
12	PC853 - Turkish	on request
13	PC857 - Turkish	on request
14	PC737 - Greek	on request
15	ISO8859-7 - Greek	on request
16	WPC1252	
17	PC866 - Cyrillic 2	
18	PC852 - Latin 2	on request
19	PC858 for Euro symbol at position 213	
20	KU42 - Thai	on request
21	TIS11 - Thai	on request
26	TIS18 - Thai	on request
30	TCVN_3 - Vientamese	on request
31	TCVN_3 - Vientamese	on request
32	PC720 - Arabic	on request
33	WPC775 - Baltic Rim	on request

<CodeTable>	Character Tables	
34	PC855 - Cyrillic	on request
35	PC861 - Icelandic	on request
36	PC862 - Hebrew	
37	PC864 - Arabic	
38	PC869 - Greek	on request
39	ISO8859-2 - Latin 2	on request
40	ISO8859-15 - Latin 9	on request
41	PC1098 - Farci	on request
42	PC1118 - Lithuanian	on request
43	PC1119 - Lithuanian	on request
44	PC1125 - Ukranian	on request
45	WPC1250 - Latin 2	
46	WPC1251 - Cyrillic	
47	WPC1253 - Greek	
48	WPC1254 - Turkish	
49	WPC1255 - Hebrew	
50	WPC1256 - Arabic	
51	WPC1257 - Baltic Rim	
52	WPC1258 - Vientamese	
53	KZ1048 - Kazakhstan	on request
255	Space page	

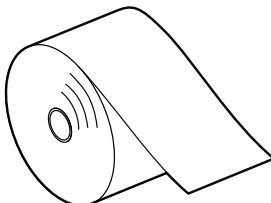
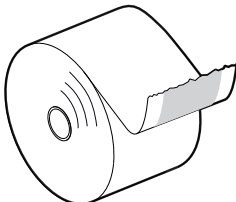

8 CONSUMABLES

The following table shows the list of available consumables for device:

DESCRIPTION	CODE
<p>THERMAL PAPER ROLL</p> <p>Width = 57mm Ø external = 50mm Ø core = 12mm Length = 30 mt</p>	<p>67300000000344</p> 
<p>LINERLESS THERMAL PAPER ROLL</p> <p>Width = 57mm Ø external = 50mm Ø core = 12mm Length = 16 mt</p>	<p>67300000000346</p> 

9 ACCESSORIES

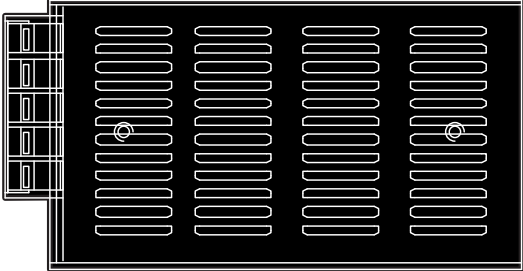
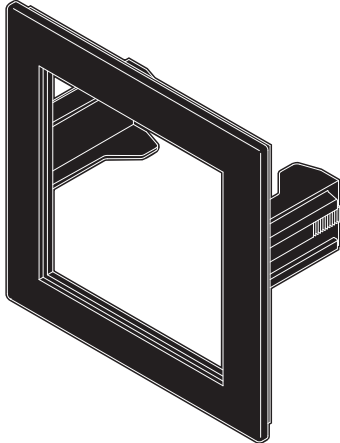
The following table shows the list of available accessories for device:

DESCRIPTION	CODE
POWER SUPPLY (for technical specifications, see the paragraph 7.1)	964GE01000003 
GREY FRAME 112X112 (WITH CLIPS) (see the paragraph 9.1)	974CW01000315 
CABLE KIT POWER SUPPLY + SERIAL/TTL INTERFACE 5 VOLT (500mm)	4400000033000 
8÷42 VDC EXTENDED RANGE MODULE	979CW18000001 

9.1 Grey frame 112X112

An adaptor frame is available and makes the device mechanically compatible with CUSTOM F and P series panel printers.

The kit is composed of:

1. Fixing clips (No.2)
2. Adaptor frame

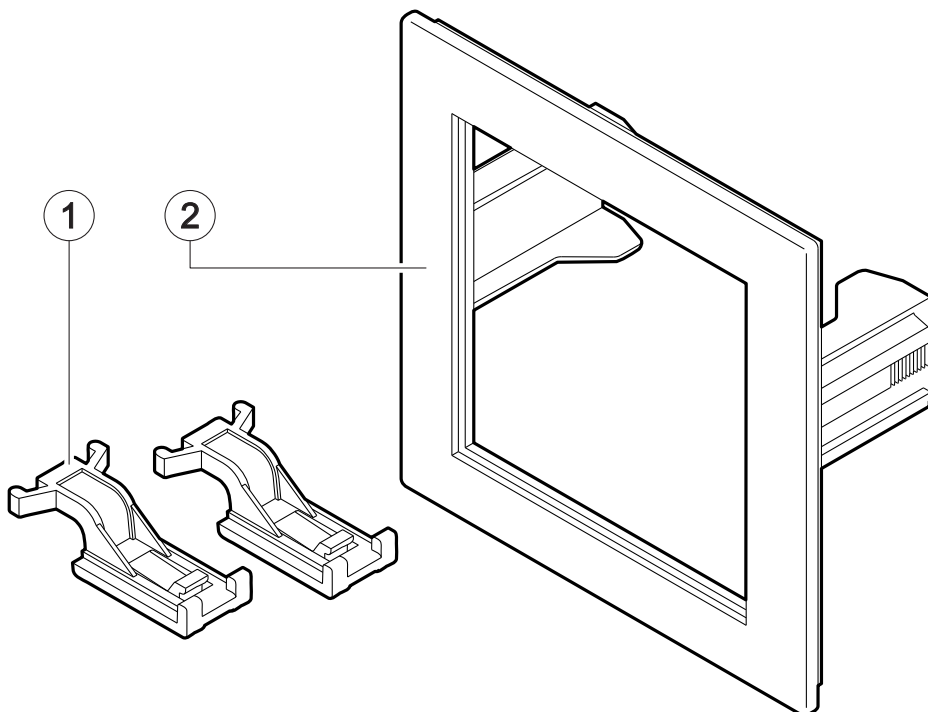

WARNING:

Pay attention that the external frame, the cover and the printer frame are made from polypropylene, so it's better to keep away from:

Ammonia, Methanol, Acetone, Washing-up liquid, Benzol, Dishwasher liquid, Hydrocarbon, Dichloromethane, Perchloroethylene, Ethylene, Trichlorethylene, Toluene.

Assembly instructions

NOTE: All the dimensions shown in following figures are in millimetres.

1

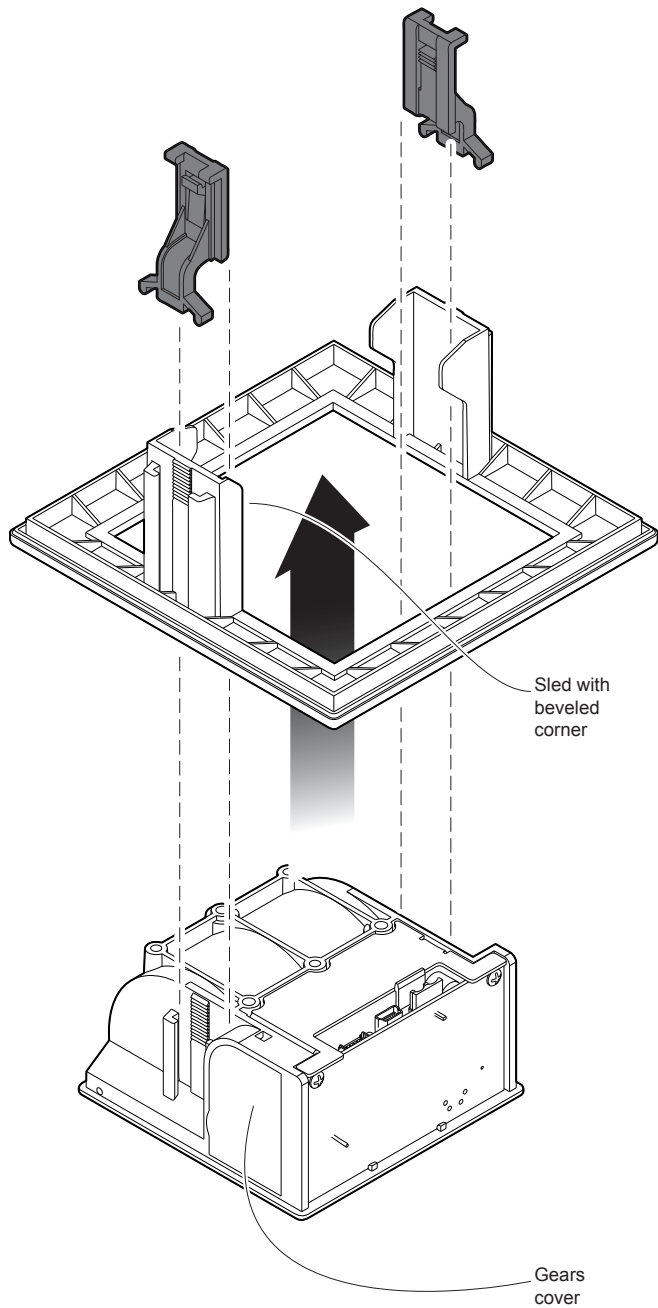

Fit the device into the frame, making sure to orient the side of the gears cover at the sled for hooking of the frame (with beveled corner). Secure the printer by using the clips supplied with the device.

2

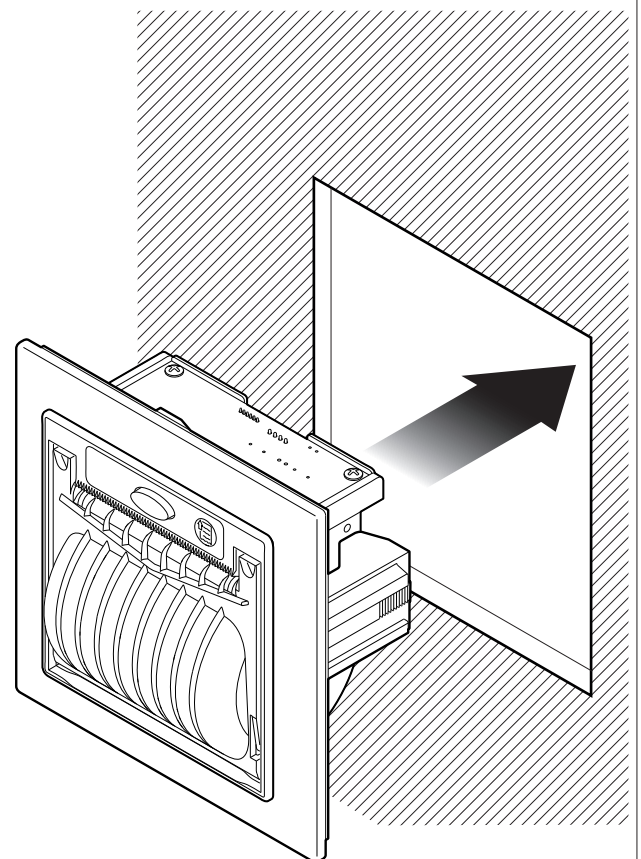
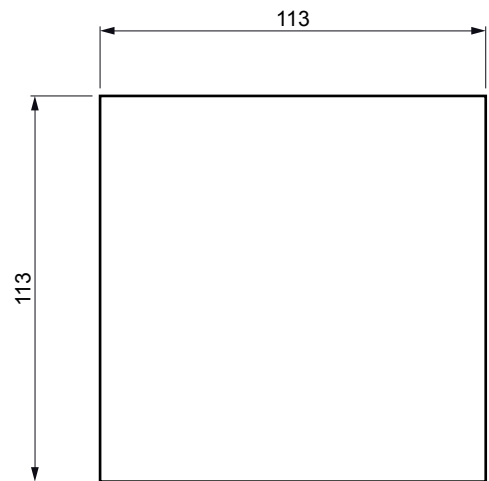

Insert the device assembled with the frame inside the panel

3

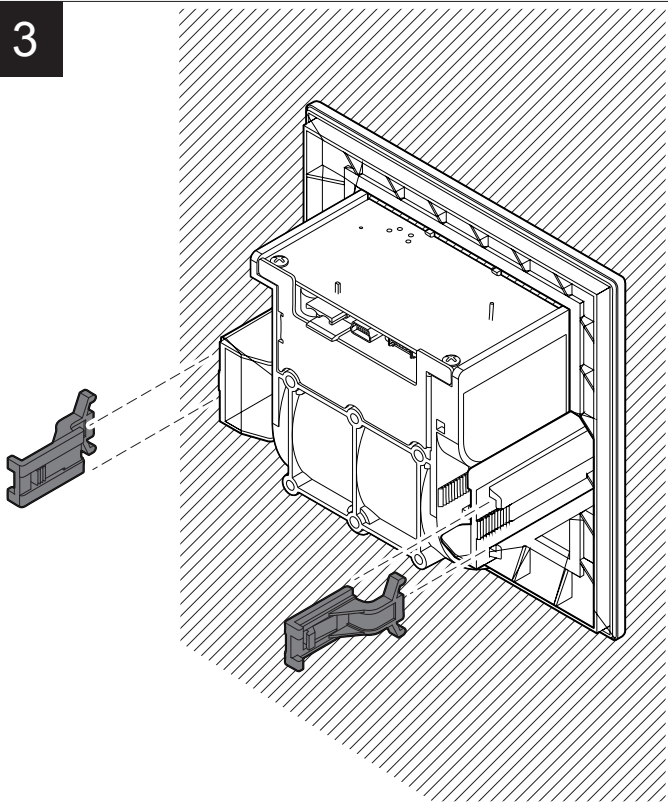

Insert the fixing clips included in the assembly kit into the seat on both the frame sides

4

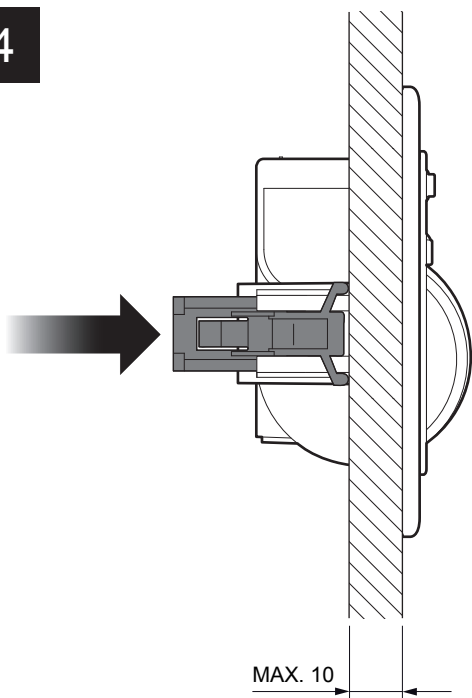

Push the two fixing clips to strike the panel

5

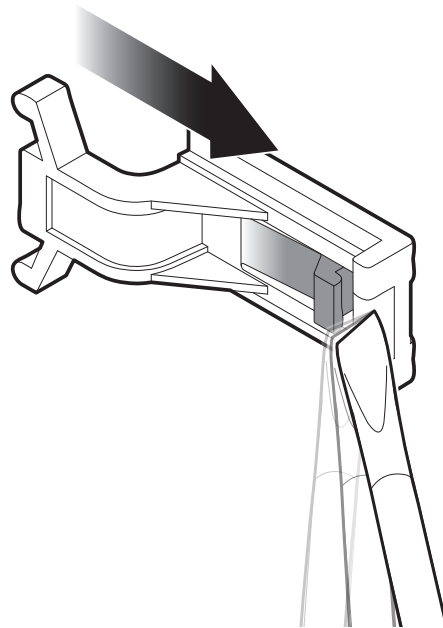

To remove the fixing clips lift the lever shown in figure with a small screwdriver

Printer dimensions with the frame assembled

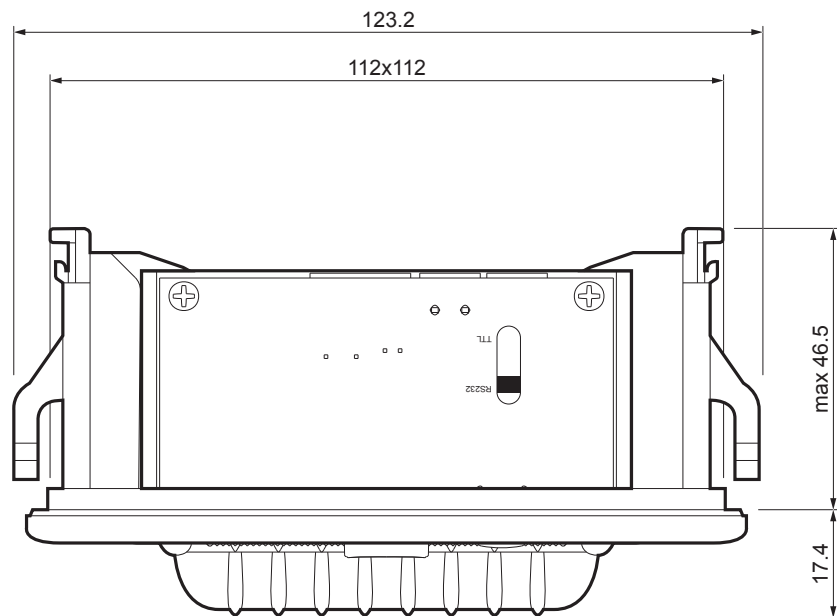
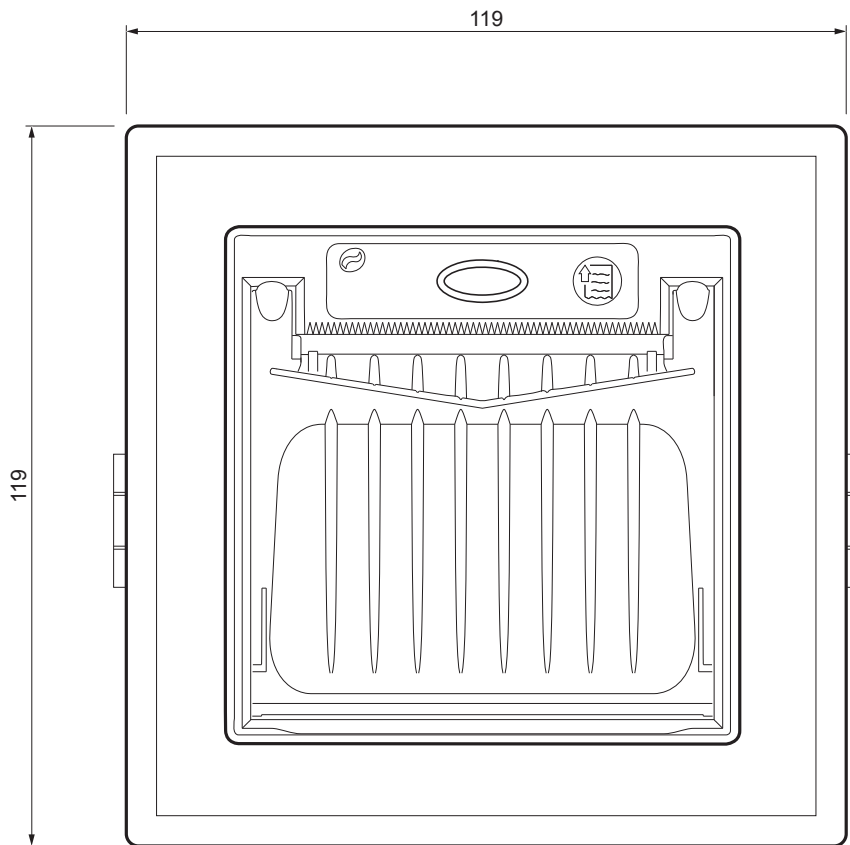

10 TECHNICAL SERVICE

In case of failure, contact the Technical Service by sending an e-mail to support@custom.it detailing:

1. Product code
2. Serial number
3. Hardware release
4. Firmware release

To get the necessary data, proceed as follows:

1

XXXXXXXXXXXXXXXXX Rx



00000000000000000000

Write down the data printed on the product label (see paragraph 2.3)

2

FW

[**FAST PUSH**] to skip Setup
[**PUSH**] to enter Printer setup

PLUS2 printer

SCODE <code>	-	rel 1.00
FCODE <code>	-	rel 1.00

PRINTER SETTINGS

PRINTER TYPEPLUS2
PRINTING HEAD TYPEE48-CE
INTERFACERS232
PROGRAM MEMORY TEST.....OK
DYNAMIC RAM TEST.....OK

Print a Setup report (see paragraph 5.1)
The Setup report shows the firmware release

3



↓

support@custom.it
Customer Service Department

Send an e-mail to the Technical Service, with the data collected

CUSTOM[®]

CUSTOM S.p.A.

World Headquarters

Via Berettine, 2/B - 43010 Fontevivo, Parma ITALY

Tel. +39 0521 680111 - Fax +39 0521 610701

info@custom.biz - www.custom.biz

All rights reserved