

CHEMINSTRUMENTS
HOT ROLL LAMINATOR
MODEL HL-100, HL-101
OPERATING INSTRUCTIONS

PRODUCT DESCRIPTION.....	2
SPECIFICATIONS	3
UNPACKING.....	3
ASSEMBLY	3
Key Components.....	5
SAFETY FEATURES	7
Trip Wire.....	7
Emergency Stop Button.....	8
TEMPERATURE CONTROLLER OPERATION.....	8
OPERATION	10
Theory of Operation.....	10
Laminating Procedure.....	10
OPTIONS.....	11
Gap Adjusters.....	11
Chrome Plated Steel pressure Roll (HL-101).....	12
Tension Unwind	11
Pneumatic Foot Control	12
Driven Heated Pressure Roll.....	12
Heated Drive Roll	12
MAINTENANCE.....	13
Tightening Belt	13
Air Connections	13
Safety Trip Wire Adjustment	14
Troubleshooting	15
WARRANTY	16

PRODUCT DESCRIPTION

The ChemInstruments Hot Roll Laminator is a state of the art laboratory scale pressure roll laminator with controlled heat.



Warning! This equipment can cause injury if not used properly. It is the operator's responsibility to observe all safety rules and warnings.

The unit has the following features:

- Hard coat anodized, Teflon coated aluminum top pressure roller. Model 101 has chrome plated steel top roll
- Top heated roller is pressure controlled with an easy to read dial indicator.
- Bottom drive roll is covered with 80-durometer-silicone rubber.
- Variable speed control of the drive rolls in both forward and reverse directions.
- Easy to use programmable temperature controller
- Safety features include a trip wire, which lifts the pressure roller and stops the motor.
- Another safety feature is the emergency stop (E Stop) switch that will open the nip and disrupt power to the entire unit.
- There is also the optional Heat Guard that provides an open mesh guard over the top heated roll.



SPECIFICATIONS:

Electrical	120 VAC/14A/60 or 240 VAC/7A/50				
Air Pressure	40 to 100 PSI				
Speed	to 20 FPM (to 6 MPM)				
Width	39" (98cm)	Depth	14" (36 cm)	Height	30" (76 cm)
Maximum opening at nip	2" (51 mm)				

UNPACKING

ChemInstruments has made every effort to ensure that the HL-100, HL-101 arrives at your location without damage. Check the unit for any damage that might have occurred in shipment. Make sure that no air lines have been disconnected and that the top roll has not been scratched. Check all packaging material carefully for individually wrapped accessories. If any damage did occur during transit, notify the **carrier** immediately.

ASSEMBLY



Warning! Due to its weight and size, use two people to move the HL-100/101.

The laminator should be set up on a sturdy bench, which will allow access to both the front and back of the machine. Some users have found a cart useful in reaching the front and back and also allow the unit to be mobile. Whether on a permanent bench top or a cart the weight of the unit (160 to 185 lbs.) must be considered.



Warning! Before proceeding with using the HL-100/101, it is advisable to become familiar with the Key Components of the laminator. These Key Components and a brief description of their function follow in the next section.

- Carefully remove the kraft paper from the laminating rolls.
- Attach the incoming airline to the machine. Use a female quick disconnect
- Set the laminator's air pressure regulator at 40 PSI for a midpoint starting pressure.
- Plug the laminator into a 120 VAC outlet or 240 VAC if requested as an option.

- The laminator will draw 12 – 15 amps at 120 volts.



Warning. Check the amp maximum for the circuit and be sure other electrical devices on the same circuit do not cause an overload.

- Remove the wooden blocks between the rollers. Save these wood blocks and insert them between the rolls when the unit is not in use! This will prevent indentations or flat spots from occurring on the rubber coverings of the roll(s).
- Press the red UP button to raise the pressure roll and remove these blocks.
- If equipped with the optional gap adjusters, create a gap by turning the middle portion of the air

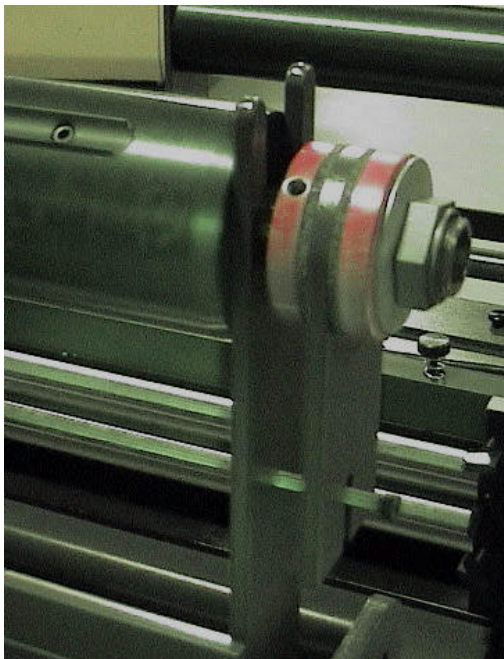

Photo 1 – Optional Brake Unwind

pistons in clockwise direction. The gap adjusters can be used to create a gap between the rollers when the machine is not in use. This gap will assure the top pressure roll is not resting on the rubber covered silicone roll when not in use thus preventing an indentation or flat spot from occurring on the rubber covered roller. (See Figure 1 for Gap Adjusters location)

- Be sure the roll unwind bar is seated correctly in the mount.
- If equipped with the optional tension unwind, be sure the pressure plate is positioned over the pin. (See Photo 1 Optional Brake Unwind)

The unit is now set up for laminating. See the Temperature Controller Operations manual for heating instructions.

KEY COMPONENTS (See Figure 1 below)

- **MOTOR POWER SWITCH** for drive motor is located on the control panel.
- **HEAT POWER SWITCH** for the heating element and is located on the control panel.
- **AIR REGULATOR** controls air pressure and is located on the back of the control cabinet
- **PROGRAMABLE HEAT CONTROL** provides set and current temperature reading of the heated roll and is located on the control panel
- **EMERGENCY STOP SWITCH** disrupts power to the entire machine, causes the top roll to rise and open the nip. It is located on the top of the control cabinet.
- **FORWARD/REVERSE SWITCH** controls the direction of the drive roll's rotation, and is located on the control panel.

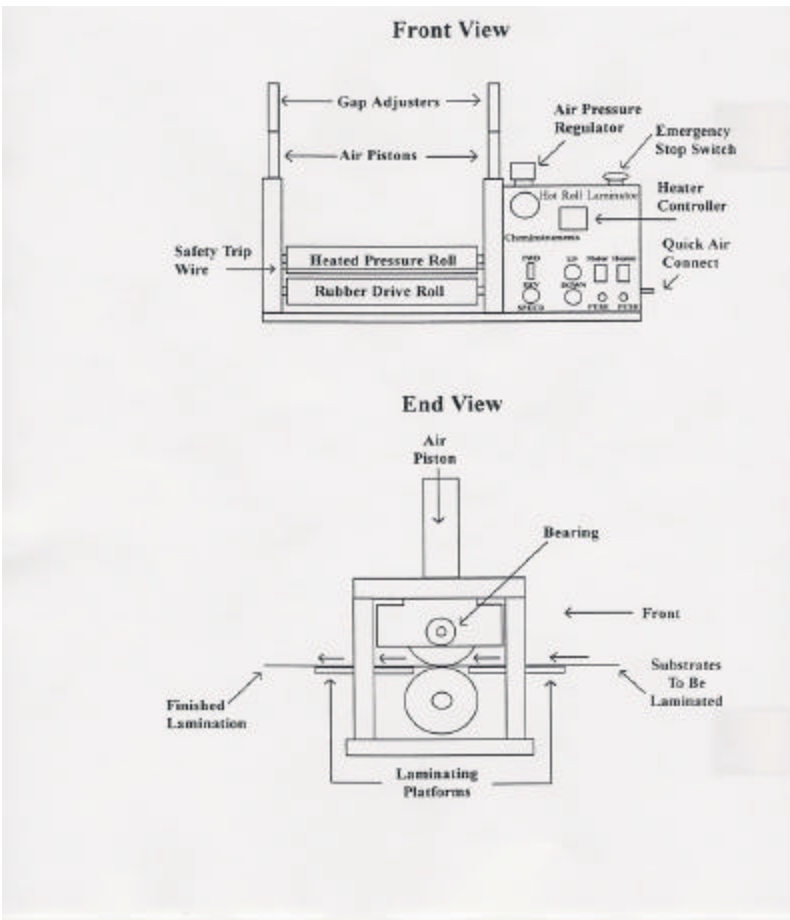

Figure 1 - Key Components

- **SPEED CONTROL** regulates the speed of the drive roll and is located on the control panel.
- **SAFETY TRIP WIRE** is located at the entrance of the nip and when it is triggered, opens the nip by raising the top roll.
- **QUICK AIR CONNECT** is the incoming airline connection and is located on the side of the control cabinet.
- **HEATED PRESSURE ROLL** on most models is the top roll of the laminator.
- **RUBBER DRIVE ROLL** on most models is the bottom

roll of the laminator.

- **NIP** is the pinch point where the two laminating rolls meet.
- **AIR PISTONS**, one on each end of the top-laminating roll moves the roll up and down.
- **GAP ADJUSTERS** provide adjustable mechanical stops that create a gap between the laminating rolls.
- **BEARINGS** are located at the end of each laminating roll shaft.
- **LAMINATING PLATFORMS** are provided on both sides of the nip for material control on entry and exit.

SAFETY FEATURES

The Hot Roll Laminator should be considered as any other piece of laboratory equipment. The safety features will not prevent injury. These safety devices will raise the top roll or stop the drive roll instantly. The objective is to prevent having to use these features. The following safety steps must be followed.



- **Tuck in ties and roll up sleeves. Loose clothing can be pulled into the laminating rolls and cause severe injury.**
- **Remove rings and watches. These will only increase your injury if caught in the laminator.**
- **Warning! Possibility of crushing/pinching. 1) Do not insert limbs into the nip area while rolls are rotating. 2) Do not lower the top roll while limbs are in the nip area.**



TRIP WIRE

Located in front of the top-laminating roll. When activated this will cause the pressure roll to rise and the drive roll to stop, allowing trapped articles to be freed. Test the trip wire by lowering the pressure roller and moving the trip wire. (See Photo 2)

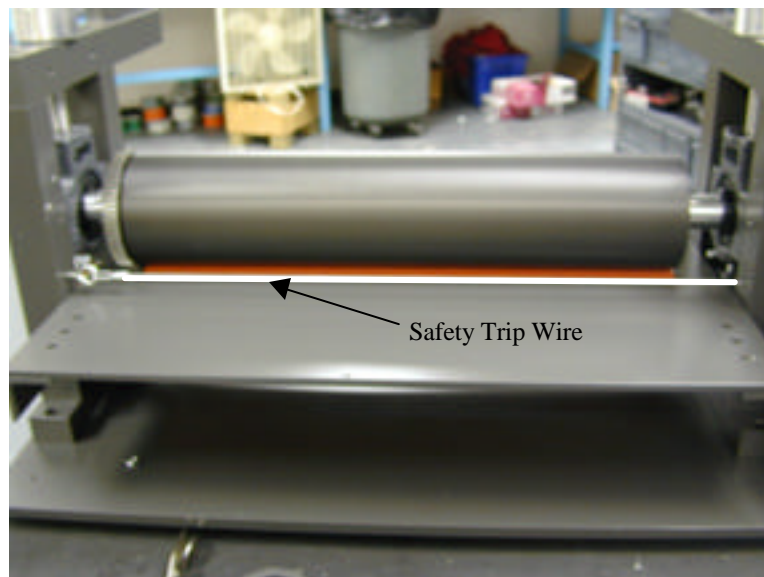

Photo 2 – Safety Trip Wire

E STOP

The Emergency Stop button will disrupt all power to the HL-100/101. It will also cause the top lamination roll to retract to the up position, thus opening the nip. The E Stop is located on the top of the control cabinet for easy access (See Photo 3). This switch is not intended to be an “on/off” switch and should not be used as such.

TEMPERATURE CONTROLLER OPERATIONS

The temperature controller is set and tested at the factory before shipment. Auto tuning has been performed at 250° F. It is ready to begin operating as soon as the HEATER switch is turned on.



Photo 3 – Control panel

(See Photo 3)

Allow the unit 45 minutes to one hour to fully stabilize to the set temperature. This also applies when changing temperatures. (See Temperature Controller Manual Enclosed).

To change the temperature set point:

- Press the SET/ENT button
- The brightly lit number is the number that will be changed. Use the left arrow button to select the number you would like to change.

- Use the up and down arrows to change the number.
- Once the new set point (SP) has been entered press the SET/ENT button again to save the new value. If the set enter button is not pushed the controller will continue at the previous temperature.
- When no buttons are pressed for a period of one (1) minute, the controller returns to normal operating mode automatically. Press SET/ENT again to continue changing the set point if desired.



WARNING: After the heater switch is turned on, the internal temperature of the heated roll(s) will rise very quickly. The 45 minutes mentioned above is the time for full roll temperature to stabilize. The surface of the roll will be hot whenever the heater switch is turned on.

DO NOT TOUCH THE HEATED ROLL(S) AFTER THE HEATER IS TURNED ON!!

OPERATION

THEORY OF OPERATION

ChemInstruments Hot Roll Laminator provides laminating capability with pressure and if desired heat. Sample material is placed between the laminating rolls where pressure and heat cause the samples to laminate together.



Warning: Before operating the laminator see page 7 for safety precautions.

LAMINATING PROCEDURE

- Raise the pressure roller (Red UP button), turn temperature controller on and allow the temperature to stabilize.
- Set the speed as necessary for your material. Turn the motor OFF after the speed is set.
- If the material is in roll form place it on the unwind stand with the heat activated side up and the uncoated side to the roll. Thread the material over the idler roll and through the pressure nip gap. Place the other material under heat-activated substrate.
- If you are working with hand sheets lay one on top of the other and place one end of the assembly in the pressure nip gap. Check to be sure the coated side is between the sample substrates.
- After the material is positioned to be laminated, push the DOWN green button and turn the motor switch to the ON position.
- As the sample moves through the laminating nip, it may be necessary to guide the sample over the rear sample platform.
- When the lamination is finished, turn the motor to the OFF position and press the UP (red) button to release the pressure.
- Insert the wooden blocks between the roller shafts when the machine is longer in use. Do not allow the rolls to rest together. This will cause flat spots to develop on the rubber roll.

OPTIONS

GAP ADJUSTERS

To set a mechanical gap between the laminating rolls, use the following procedure.

- To create a specific known gap, place feeler gauges between the rollers. For the best results use 2 sets of feeler gauges. Place the gauges at about 6 inches from each end of the rolls.
- Turn the center section of the air cylinders to provide a mechanical stop for the top-laminating roll.
- Continue to adjust this center section of the air cylinders until the gap between the laminating rolls is the same as the feeler gauges.
- Replace the wooden blocks or use the gap adjusters to prevent the rolls from resting together when the laminator is not in use.

CHROME PLATED STEEL PRESSURE ROLL (HL-101)

- The top pressure roll is chrome-plated steel that will create smoother laminations when working with thin gauge films.
- The chrome plated roll has been installed at the factory and is ready for use.

TENSION UNWIND

In order to laminate many materials, it is necessary to have appropriate back tension on the sample material to be laminated. Use the following procedure to set and adjust the tension unwind.

- The tension unwind consists of a core insert with a spring-loaded blade that prevents the face stock from turning and a pressure plate brake.
- Load the material over the open end of the core insert.
- Center the material over the spring loaded blade.
- Place the material in the unwind holders; making sure the pressure plate is aligned over the stop pin.

- To increase the tension, loosen the setscrews on the large nut on the pressure plate. Then turn the large nut clockwise. Once the right tension has been established tighten the setscrew

PNEUMATIC FOOT CONTROL

This control is used to switch either the motor drive roll on and off or to move the top pressure roll up and down. In order to do either, use the following procedure.

- Simply activate the foot control by pressing on the switch plate.
- When activated this feature will lower the pressure roller while you hold samples in place.
- Extreme caution should be taken when using this feature to assure that only the sample is near the nip when lowering the pressure roll. (See page 7 for safety issues).
- If the foot control is connected to the motor, then activating the switch plate will start and stop the drive roll of the laminator.

DRIVEN HEATED PRESSURE ROLL

- This feature uses gears on the bottom roll and the top heated roll. These cause both rolls to turn simultaneously.
- The gear located on the left end of the rolls will engage when the pressure roll is lowered to meet with the bottom rolls gear.

HEATED DRIVE ROLL

- The bottom driven roll is independently heated with a second temperature controller.
- Each controller is marked for the roll it is heating.
- See the separate temperature controller manual for instructions on operation.
- Maximum recommended temperature is 400°.

MAINTENANCE

The ChemInstruments Hot Roll Laminator should provide many years of trouble-free service. However, some maintenance may be necessary. The following are the maintenance procedures:



WARNING: Always unplug the unit before opening the control cabinet. Electric shock may occur.

TIGHTENING DRIVE BELT

Should you need to replace or adjust the drive belt, please follow the procedure below.

1. Remove the six screws holding the faceplate.
2. Remove the four screws holding the side panel.
3. Carefully pull these two panels away from the control box.
4. Make sure not to pull any wires or air hoses loose.
5. Loosen the four (4) motor mount screws.
6. Pull the motor to tighten the belt.
7. Tighten the motor mount screws.
8. Reinstall the front and side panels.

AIR CONNECTIONS

In the event that an air leak develops the following procedure will guide you through repair



Warning: Before opening the cabinet to search for air leaks or to do any work inside the cabinet disconnect the power cord.

1. Find the source of the leak, and then disconnect the air supply from the unit. The tubing is very flexible and is pushed onto a small barb at each connection.
2. Cut the tubing off the barb.
3. Cut off any bad section of the tubing.
4. Push the tubing back onto the barb.
5. If there is not enough good tubing to reconnect, trace the tubing to the next fitting connection and replace the entire section of tubing.

SAFETY TRIP WIRE ADJUSTMENT

If the pressure roller will not lower when the green DOWN button is pressed, the safety trip wire may need adjustment. To adjust the safety trip wire, follow this procedure.



Warning: When working on the HL-100/101 Hot Roll Laminator, it is always best to disconnect power and air supply. Before disconnecting the air supply, secure the top roll in the up position with blocks of wood or the optional Gap Adjusters.

1. Push or pull the wire to verify that there are two audible "clicks;" one as the wire is pushed and the other as it is released.
2. If you do not detect the click of the switch when the trip wire is pulled or pushed, loosen the eyebolt on the left side of the safety trip wire by loosening the set nut, and then turning the eyebolt counter-clockwise.
3. Tighten or loosen the eyebolt until there is a "click" when the trip wire is pulled or pushed.
4. Hold the eyebolt securely and tighten the set nut on the eyebolt.

CLEANING

From time to time the rolls may need to be cleaned. The laminating platforms can be moved to allow easier access to the rolls. To do this, loosen the black plastic thumbscrews, slide the platform, and then re-tighten the thumbscrews.



Warning: Always clean rolls with the power off and the heated roll cold to the touch. Do not clean the rolls while they are moving, and always clean the pressure roll while it is in the "up" position.

Mineral spirits may be used to clean both of the rolls. *Do not use toluene, as it will damage the rubber roll.* Do not clean the rolls while they are moving, and always clean the pressure roll while it is in the "up" position. Do not scrape the pressure roll with any objects! Use only a soft cloth and mineral spirits to clean this roll.

If you have any questions regarding the maintenance or the operation of your Hot Roll Laminator, or need to order replacement parts, feel free to call ChemInstruments at 513-860-1598, Monday - Friday from 8:00 AM to 5:00 PM EST. Or you may fax us at 513-860-1597.

TROUBLESHOOTING

Problem	Probable Cause	Procedure
Motor switch not lit.	Machine not plugged in.	Plug machine into 120 VAC outlets.
	Blown fuse.	Replace with a 2-amp time delay fuse.
Heater switch not lit.	Machine not plugged in.	Plug machine into 120 VAC outlets.
	Blown fuse.	Replace with a 15-amp fuse.
Rollers do not turn.	Motor speed set at zero.	Increase motor speed.
	Gear belt loose.	Tighten gear belt. (SEE BELOW - A)
Air hose leaks.	Loose connection.	Repair connection. (SEE BELOW - B)
Pressure roller will not lower.	Safety trip wire sticking.	Adjust safety trip wire. (SEE BELOW - C)
No air pressure.	Airline not connected.	Connect machine to compressed air line.