



IPM3300 Multi-Function Power Meter



User guide

IA Networks Technology Co., Ltd.

5F-1, No.44, Sec. 2, Roosevelt Rd., Taipei, Taiwan

TEL : 886-2-2395-3153 FAX : 886-2-2395-3152

http:// www.iantech.com.tw E-mail : market_infor@iantech.com.tw

Content

Chapter 1 Introduction

- 1.1 Product Introduction
- 1.2 Caution
 - 1.2.1 Danger
 - 1.2.2 PRODUCT WARRANTY & CUSTOMER SUPPORT
 - 1.2.3 LIMITATION OF WARRANTY
- 1.3 Specification

Chapter 2 Installation

- 2.1 Safety
- 2.2 Mounting
 - 2.2.1 Size and Latch

Chapter 3 Connection

- 3.1 Back view of connect port
 - 3.1.1 Aux. Power Supply
 - 3.1.2 Digital Output
 - 3.1.3 Current Terminal
 - 3.1.4 Voltage Terminal
- 3.2 Wiring diagram
 - 3.2.1 1P2W/1CT
 - 3.2.2 1P3W/2CT
 - 3.2.3 3P3W/2CT
 - 3.2.4 3P3W/3CT
 - 3.2.5 3P4W/3CT

Chapter 4 Display and setup

- 4.1 Display
- 4.2 Operation
 - 4.2.1 「M」 Button
 - 4.2.2 「P」 Button
 - 4.2.3 「E/T」 Button
 - 4.2.4 「V/A」 button
- 4.3 Setting 「M」、「P」、「E/T」 and 「V/A」
 - 4.3.1 General Setting (N)
 - 4.3.2 Clear Setting (C)
 - 4.3.3 Alarm Setting (A)

Chapter 5 Communication format

- 5.1 RS485
 - 5.1.1 RS485 standard
 - 5.1.2 Wiring for instruments communication
- 5.2 Modbus
 - 5.2.1 Modbus Format
- 5.3 Communication protocol
- 5.4 IEEE 754 Format
- 5.5 Modbus RTU Mode
- 5.6 Modbus Function Code
- 5.7 IPM3300 Parameter

Chapter 1 Product Introduction

1.1 IPM3300 Introduction

IPM3300 is designed for single and three phase power monitoring and measurement. It provides wide range of measurements including current, voltage, energy, watt, power factor, watt-hour, frequency...etc.

Product Features :

- Comply IEC62053-22 Class 0.5 standard
- V · I accuracy <0.2%, Wh<0.5%, with bi-directional energy measurement
- More than 90 parameters measure
- Current direction setting to correct the display value
- Large size of LCD with backlight adjustment in 4-stage, easy to operate
- Power Quality measurement in V/I unbalance · V Eligibility · Min.& Max. parameters
- Compact size, standard DIN 96*96, equipped with four clips to tight the meter on the sheet metal
- With RS485 communication protocol

1.2 Caution



1.2.1 Danger

The meter contains hazardous voltages. The meter should never be disassembled. Failure to observe this practice can result in serious injury or death. Any work on or near energized meters, meter sockets, or other metering equipment can present a danger of electrical shock. It is strongly recommended that all work should be performed only by qualified industrial electricians and metering specialist. IA networks Corporation assumes no responsibility if your electrical installer does not follow the appropriate national and local electrical codes.

1.2.2 PRODUCT WARRANTY & CUSTOMER SUPPORT

IA Networks Corporation warrants all products free from defects in material and workmanship for a period of one year from the date of shipping. During the warranty period, we will, at our position, either repair any product that proves to be defective. To report any defect, please contact : **+886-2-2395-3153** or **smarket_infor@iantech.com.tw**

Please have the model, serial number and a detailed problem description available when you call. If the problem concerns a particular reading, please have all meter readings available. When returning any merchandise to IA Networks Corporation a return SN. is required.

1.2.3 LIMITATION OF WARRANTY

This warranty does not apply to defects resulting from unauthorized modification, misuse, or use for reason other than electrical power monitoring. The supplied meter is not a user-serviceable product.

1.3 Product Spec.

Aux Power	AC80-264V/DC100-300V, Max.2.3W
Input Voltage	CATII 10V-600V L-L*
Input Current	2mA-5A
Accuracy	V、I 0.2%、W 0.5% (PF=1.0)
Frequency	45-65Hz
Measures	V, I, kW, kvar, kVA, kWh, kvarh, kVAh PF, Frequency, Demand, Running hour
Alarms	NONE、OVER V/I、OVER F； UNDER V/I、UNDER F； OVER Dmd； ANY
Power Quality	V/I unbalance、V Eligibility、Min.& Max. parameters
Display	Mono 68X59 LCD
Communication	RS485*1, LonTalk(option)
Timer	RTC
Wiring Ports	Aux Power、Voltage、Current、DO*2、RS485、LON
I/O	DO OUTPUT*2； DO1 Alarm output、DO2 Pulse/ Alarm output
Operation Temperature	-20°C-70°C
Storage Temperature	-25°C-80°C
Humidity	20-90%RH
Dust/Water Proof Rating	Panel：IP52、Case：IP20
Size	96(W) x 96(H) x 97(L) mm
Power consumption	0.45~0.7W (Backlight off) 1.3~1.7W (Max. ,Backlight) 2.3W (Max. Backlight & Lon module)
Environmental Conditions	Indoor use Altitude up to 2000M Transient overvoltage on the mains supply is 2500V Pollution degree：2

*CATII-Is for measurement performed on circuits directly connected to the low voltage installation

Chapter 2 Installation

2.1 Safety

On receipt of the instrument and prior to installation, makes sure it has not been damaged during shipment.

The instrument is no longer safe when,

- Shows clear signs of damage
- Does not work
- Long storage under extreme conditions
- Damage during shipment

2.2 Mounting

- This instrument should install on vibration free switchboard and with environment temperature between $-20^{\circ}\text{C} \sim 70^{\circ}\text{C}$, humidity between 20-90%RH (no condensing)
- For the instrument is already equipped with an internal protection fuse, a 1AmAT HBC fuse is still recommended during installation
- Prior to maintain/repair this instrument, always disconnect this instrument from all power sources
- Only have qualified and authorized personnel to carry out installation, maintenance and repair
- Water proof for front panel IP52, case IP20

2.2.1 Size and Latch

Front View(mm)

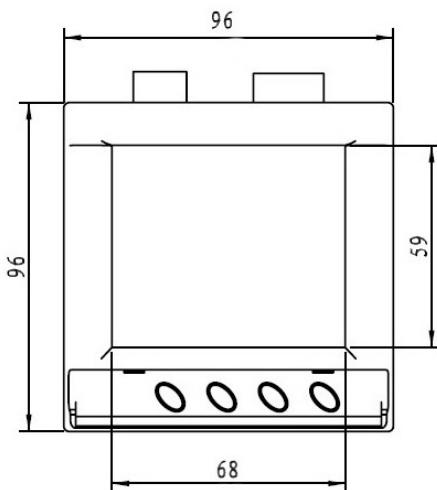

Back View (mm)

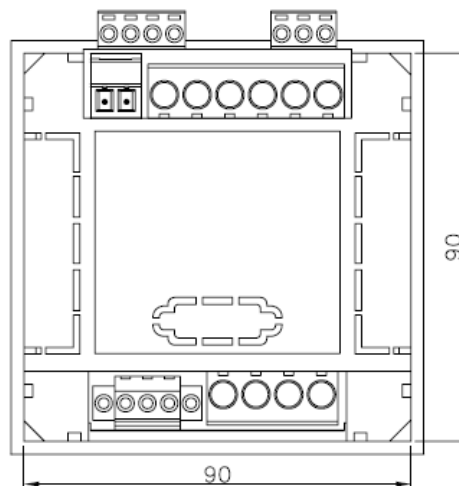

Side View(mm)

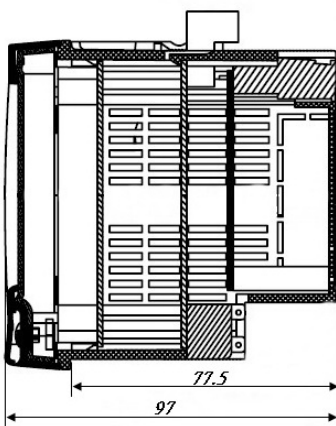

After mounting the instrument, place all four support latch in position.

Panel cut-out area is 91.5x91.5mm (+/-0.5mm)

Chapter 3 Connection

3.1 Back view of connect port

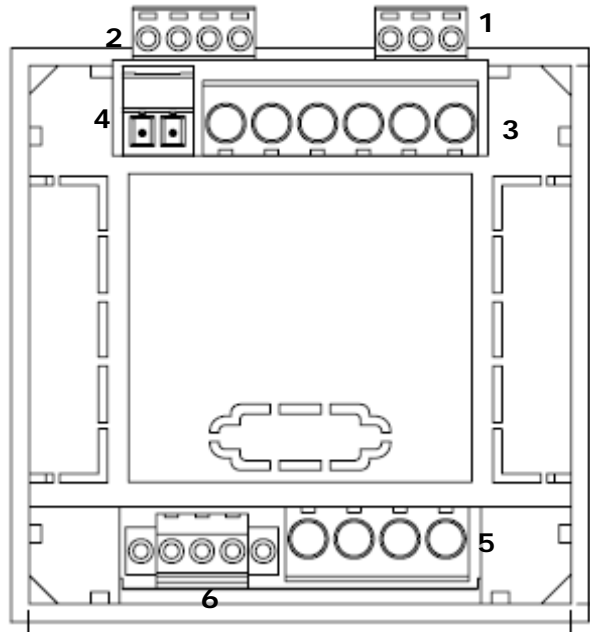

1.Aux Power(N-, ,L+)
2.Digital output (Com2 DO2 Com1 DO1)
3.Current Terminal (3L 3S 2L 2S 1L 1S)
4.Lon Port(D-,D+)
5.Voltage Terminal (N,C,B,A)
6.RS485 Port (D-,COM,D+)

3.1.1 Aux. Power Supply

- Before powering the instrument, verify the pin position at L and N, leave the middle pin blank.
- Power standard is 80-264Vac/100-300Vdc.
- An internal protection fuse 250V, 1A is equipped.
- The instrument Aux. power must not be earthed.

3.1.2 Digital Output

- 2 channel 4 pin digital output (Com2 DO2 Com1 DO1)
- 12-240VAC-DC/120mA max
- Com1 DO1 for digital output1, Com2 DO2 for digital output 2
- Port 1 assign selection : NONE 、 OVER V/I 、 OVER F ; UNDER V /I 、 UNDER F ; OVER Dmd ; ANY °
- Port 2 assign selection : Energy pulse output base on kh(wh/ pulse) setting or alarm output same as port 1

3.1.3 Current Terminal

- The current input are 3 channels/6 terminals(3L 3S 2L 2S 1L 1S)
- Input current range from 2mA to 5A (CT secondary)



Warning !

The CT input current must not exceed 10A



Warning !

Be sure to short secondary's of each current transformer, before removing the CT connection inputs.

3.1.4 Voltage Terminal

- There are 4 voltage terminals (N.C.B.A) ◦
- The instrument measure voltage from 10V-600V RMS. (PT secondary)
- Voltage must not exceed 600V, in case of over 600V, voltage transformer need to be applied.

Note !

3P3W/2CT and 3P3W/3CT wiring, only connect "C A N", and leave "B" blank

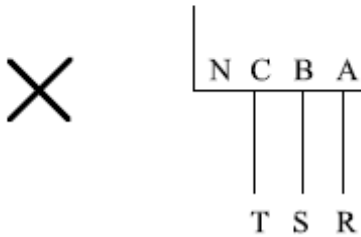
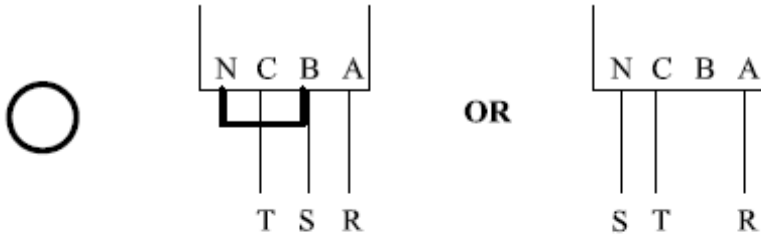

3.2 Wiring diagram

3.2.1 1P2W/1CT

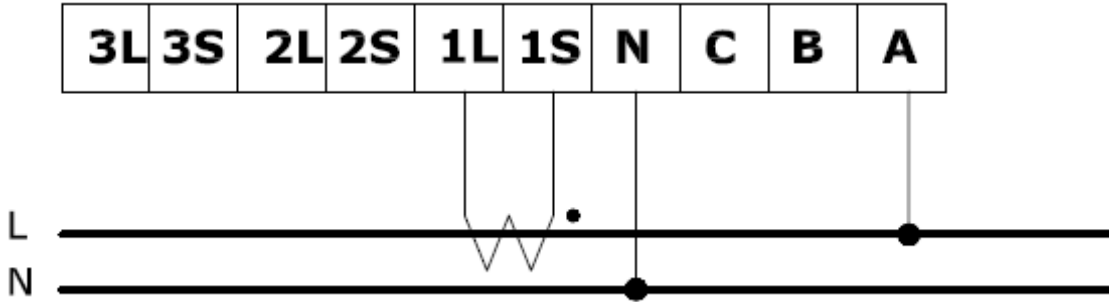

3.2.2 1P3W/2CT

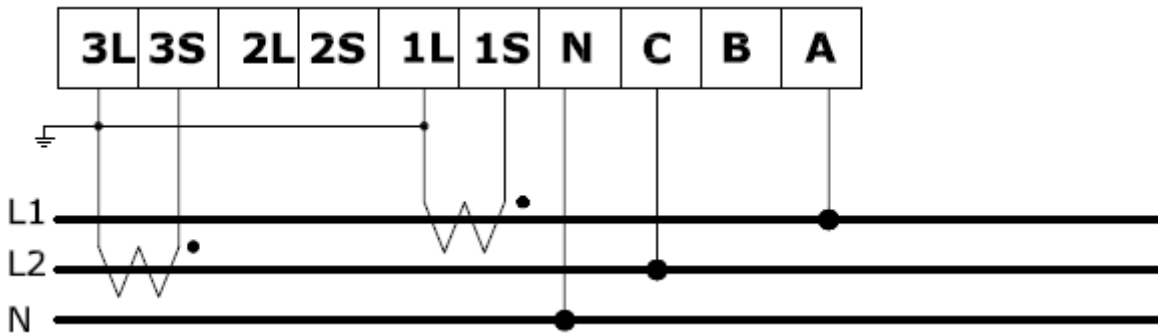

3.2.3 3P3W/2CT

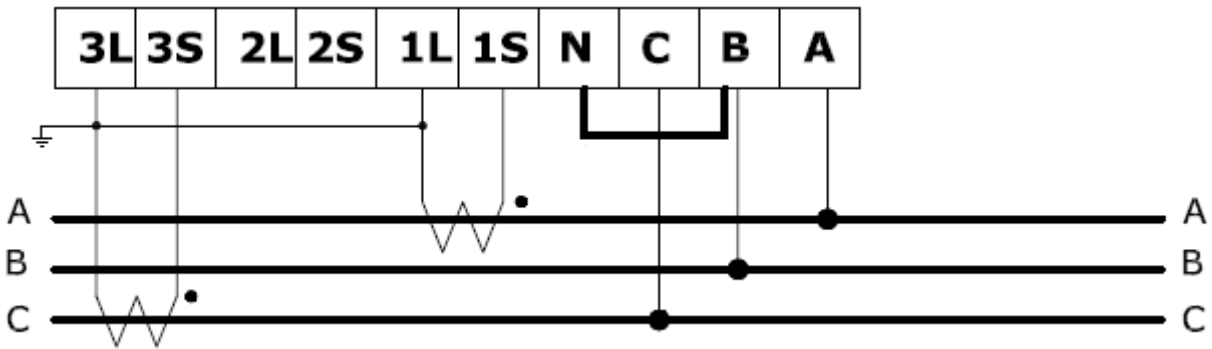

3.2.4 3P3W/3CT

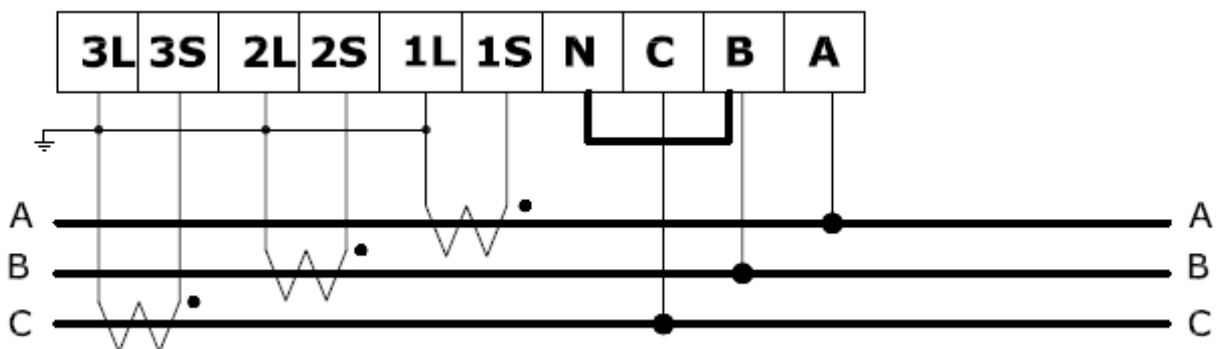

3.2.5 3P4W/3CT

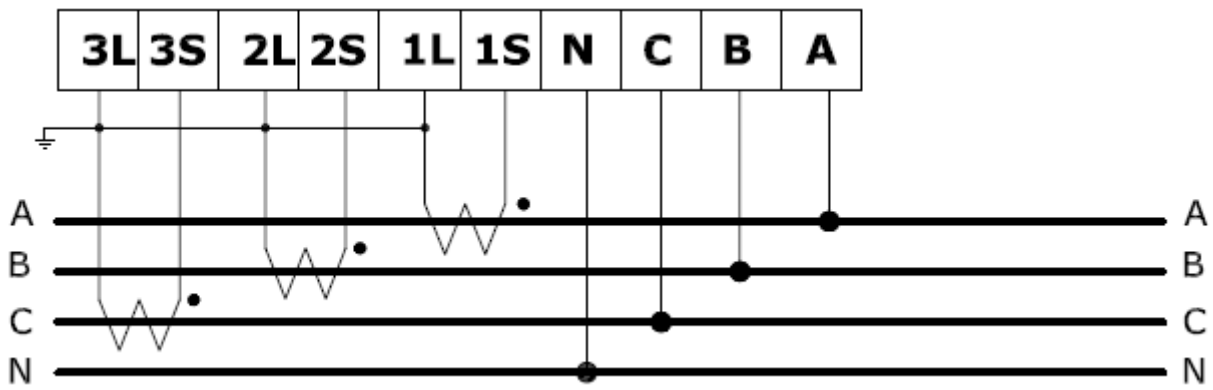

Chapter 4 Operation & Setting

4.1 Display

The IPM3300 is equipped with a large back-lit LCD and 4 function buttons. It shows up to five measurements simultaneously.

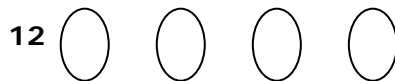
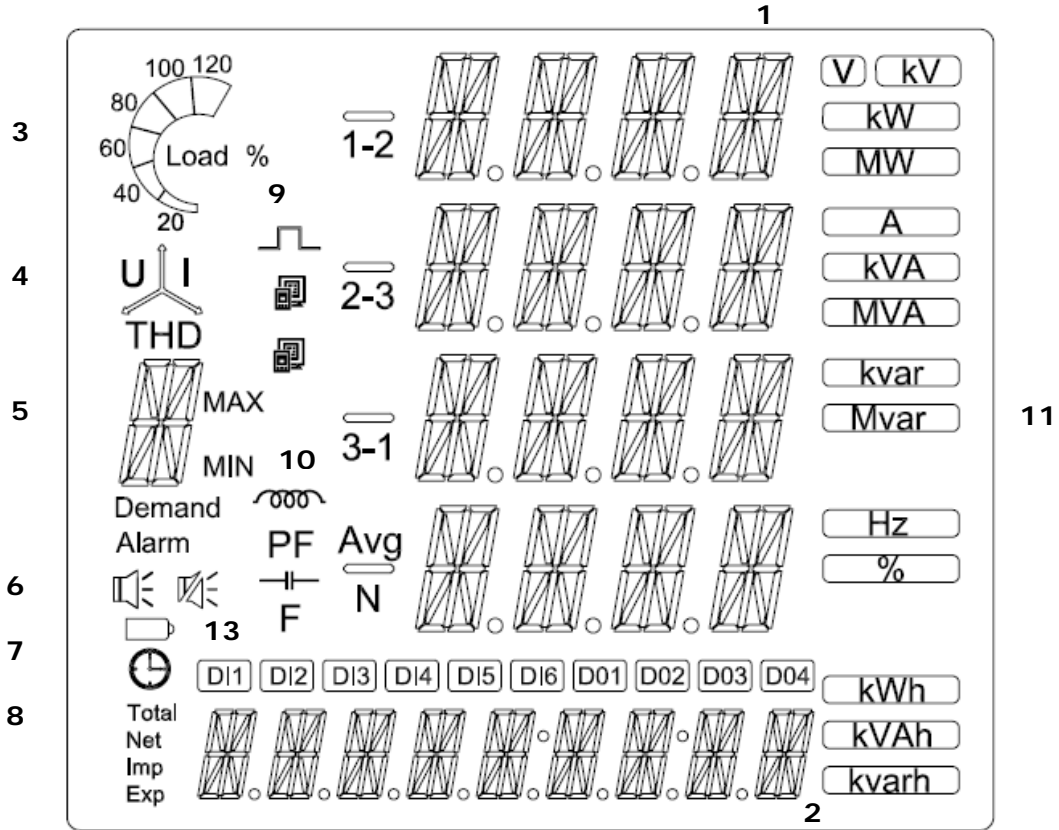

Item	Display Content
1	Values, for V,I,KW.....Demand, eligibility rate and unbalance rate
2	Values, for energy & time
3	Load percentages
4	Unbalance rate indicator
5	Types of measurement (I,U,E,P...)
6	Alarm buzzer on/off
7	Indicator for time display in zone 2
8	Indicator for energy display in zone 2
9	Indicator for pulse output and communication
10	Display for power factor and load characteristics
11	Units for measurements
12	Function Buttons, "M" "P" "E/T" "V/A"
13	DO1, DO2 Status

***THD、DI、DO3、DO4 : To be available in near future

4.2 Operation

The IPM3300 equipped with function buttons to easily view all values and modify device setting. From left to right, there are 「M」, 「P」, 「E/T」 and 「V/A」 respectively.

- Button 「M」 to display maximum and minimum values
- Button 「P」 to display power for each phase and total , power factor (PF), frequency (F) and power demand.
- Button 「E/T」 to display Energy 、RTC and running hour
- Button 「V/A」 to display Voltage and Current

4.2.1 「M」 Button

Press successively to present the maximum minimum and average values of present measure parameters. For example, if IPM3300 is currently display "Voltage" with "U" shown on the left middle of the screen, press "M" Button will show the Max./Min. and average values of Voltages. The following lists all the values that can be shown for Max./Min. and average values depending on the display parameters which are showing now

- Max./Min. Voltage(L-L , L-N , Average)
 - Max./Min. Current(Per phase , Average)
 - Max./Min. Voltage & Current unbalance rate
 - Max./Min. kW(Per phase , Total)
 - Max./Min. kvar (Per phase , Total)
 - Max./Min. kVA (Per phase , Total)
 - Max./Min. kW-t, kVA-t, kvar-t
 - Min. PF
 - Max./Min. Frequency
 - Max. Power Demand
-

4.2.2 「P」 Button

「P」 Button is for power selection. Press 「P」 Button successively to obtain:

- Active power (P) per phase and total
- Reactive power (Q) per phase and total
- Apparent power (S) per phase and total
- Total active power (P), reactive power (Q) , apparent power (S) and power factor(PF)
- Total active power (P), reactive power (Q) , apparent power (S) and frequency(F)
- Previous power demand kW, , demand subinterval remain time (sec) and current power demand kW

4.2.3 「E/T」 Button

「E/T」 Button is for Energy & Time. Press 「E/T」 successively to obtain the following values in the zone 8 (bottom lane of the screen)

- Total active energy (kWh-t)
- Total reactive energy (kvarh-t)
- Total apprerant energy (kVAh-t)
- Total meter running hours (Total)
- Total meter running hours with load (Net)
- Year-Month-Day
- Hr-Min-Sec.

4.2.4 「V/A」 button

「V/A」 button is for showing the Voltage and Current. Press button successively to obtain

- Phase to phase voltages and average (U)
- Phase to neutral voltages and average (U)
- Instantaneous current (I)
- Unbalance rate for voltages and current
- Voltage eligibility rate

4.3 Setting 「M」, 「P」, 「E/T」 and 「V/A」

To enter setting mode, press 「M」 and 「V/A」 buttons simultaneously. The setting mode is used for : basic operation, clear informal data and alarms setting

- 「M」 to move cursor right ward like 「→」
- 「P」 to move the cursor down ward like 「↓」 or 「reduce one」
- 「E/T」 to move the cursor up ward like 「↑」 or 「add one」
- 「V/A」 to confirm the selection like 「Enter」, and turn to next page
- 「M」 and 「V/A」 together to move back like 「ESC」 or back to operation display

First, to press 「M」 a 「V/A」 simultaneously to enter password entering page, it required 4 digits (default is 0000).

```
PASS
WORD
0000
```

Then, select the setting from 「BASIC」, 「ALARM+I/O」, 「CLEAR」 by used 「P」 or 「E/T」

```
P0
MAIN
MENU
BASIC / ALARM+I/O / CLEAR
```

4.3.1 General Setting (N)

N1: Address Setting from 1-255 (Default 15)

```
N1
Add
015
```

N2: BAUD RATE Setting - 4800, 9600, 19200, 38400, 57600. (Default 19200)

```
N2
BAUD
RATE
19200
```

N3: STOP BIT Setting - "1" or "2" (Default 1)

```
N3
STOP
BIT
1
```

N4: Wire Type Setting -1P2W , 1P3W , 3P3W-2CT , 3P3W-3CT , 3P4W-Y , AUTO (Default AUTO)

```
N4
WIRE
TYPE
3P4W
```

N5: PT Primary Setting from 60-600000 (Default 110)

```
N5
PT1
000110
```

N6: PT2 Secondary Setting from 1-600 (Default 110)

```
N6
PT2
110
```

N7: CT Primary Setting from 1-5000 (Default 1)

N7
CT1
0001

N8: CT Secondary Setting from 1-5 (Default 1)

N8
CT2
1

N9: BACK LIGHT TIME OUT Setting from 0-120 minutes (Default 1) .

If 0 is chosen, the back light will be always ON. Enter any key to turn on back light.

N9
BACK
LIT
120

N10: BACK LIGHT LEVEL Setting from 0-4 (Default 3).

If 0 is chosen, the back light will be always OFF.

N10
BACK
LIT
LVL
3

N11: I-1 Current Direction Setting - "Positive" or "Negative". (Default POSITIVE).

If the current is connected in wrong direction, select "Negative" to correct the display value.

N11
I-1
POSITIVE

N12: I-2 Current Direction setting - "Positive" or "Negative". (Default POSITIVE).

If the current is connected in wrong direction, select "Negative" to correct the display value.

N12
I-2
POSITIVE

N13: I-3 Current Direction setting - "Positive" or "Negative". (Default POSITIVE).

If the current is connected in wrong direction, select "Negative" to correct the display value.

N13
I-3
POSITIVE

N14: V1(V12) Voltage Eligibility Rate Up Limit Setting from 0-65535 (Scale 0.1, refer to Secondary) (Default 65535)

N14
U1
UP
LMT
65535

N15: V1(V12) Voltage Eligibility Rate Low Limit Setting from 0-65535 (Scale 0.1, refer to Secondary) (Default 0)

N15
U1
LOW
LMT
00000

N16: V2(V23) Voltage Eligibility Rate Up Limit Setting from 0-65535 (Scale 0.1, refer to Secondary) (Default 65535)

N16
U2
UP
LMT
65535

N17: V2 (V23) Voltage Eligibility Rate Low Limit Setting from 0-65535 (Scale 0.1, refer to Secondary) (Default 0)

N17
U2
LOW
LMT
00000

N18: V3 (V31) Voltage Eligibility Rate Up Limit Setting from 0-65535 (Scale 0.1, refer to Secondary) (Default 65535)

N18
U3
UP
LMT
65535

N19: V3 (V31) Voltage Eligibility Rate Low Limit Setting from 0-65535 (Scale 0.1, refer to Secondary) (Default 0)

N19
U3
LOW
LMT
00000

N20: Demand Mode Setting - 「BLOCK」 or 「ROLLING」 (Default BLOCK)

N20
DMD
MODE
BLOCK

N21: Sub-Interval Number Setting - 1,2,3,4,5,6,10, only used for "Rolling Mode" (Default 1)

N21
SUB
INTV
NUM
1

N22: Sub-Interval Length (Time) Setting - 1,2,3,4,5,6,10,12,15,30,60 min. (Default 15)

N22
SUB
INTV
LENG
15

N23: Date Setting

N23
DATE
2009.02.20

N24: Time Setting

N24
TIME
00:00:00

N25: Password Setting-four digits from 0000-FFFF (Default 0000)

N25
PASS
WORD
0000

4.3.2 Clear Setting (C)**C1: Energy Reset – Yes or No**

C1
ENRG
RST
NO

C2: Reset All – Yes or No

C2
RST
ALL
NO

C3: Reset OF Total Meter Run Hour – Yes or No

C3
RST
R-HR
TOT
NO

C4: Reset OF Net Load Run Hour – Yes or No

C4
RST
R-HR
NET
NO

C5: Demand Reset – Yes or No

C5
RST
DMD
NO

C6: Reset of Max and Min values – Yes or No

C6
RST
MAX
MIN
NO

C7: Reset to Default - Yes or No

C7
RST
DEFT
NO

C8: Reset Voltage Eligibility Rate – Yes or No

C8
RST
VER
NO

4.3.3 Alarm Setting (A)**A1: Enable Alarm – On or Off (Default OFF)**

A1
ALRM
OFF

A2: Enable Buzzer – On or Off (Default OFF)

A2
BUZZ
OFF

A3: DO1 can be assigned as the alarm output, and can be selected from 「None」, 「Any」, 「Over V」, 「Over I」, 「Over F」, 「Over Dmd」, 「Over V」, 「Under I」, 「Under F」 (Default None)

A3
DO1
ALRM
NONE

A4: DO2 can be assigned to output 「PULSE」 or 「ALARM」 (Default PULSE)

A4
DO2
OUT
PUT
PULSE/ALARM

A5: If DO2 is assigned to 「ALARM」, then select from 「None」, 「Any」, 「Over V」, 「Over I」, 「Over F」, 「Over Dmd」, 「Over V」, 「Under I」, 「Under F」 (Default None)

A5
DO2
ALRM
NONE

A6: If DO2 is assigned to 「PULSE」, then select from 「NONE」, 「kWh」, 「kvarh」, 「kVAh」 (Default NONE)

A6
PULS
OUT
PUT
NONE

A7: If DO2 is assigned to 「PULSE」, pulse rate can be 1 to 6000, 1 stand for 0.1kwh/pulse (Default 10)

A7
kh
0001

A8: Over Voltage Alarm – 「ENABLE」 or 「DISABLE」 (Default DISABLE)

A8
OVER
V
DISABLE

A9: Over Current Alarm – 「ENABLE」 or 「DISABLE」 (Default DISABLE)

A9
OVER
I
DISABLE

A10: Over Frequency Alarm – 「ENABLE」 or 「DISABLE」 (Default DISABLE)

A10
OVER
FREQ
DISABLE

A11: Over Demand Alarm – 「ENABLE」 or 「DISABLE」 (Default DISABLE)

A11
OVER
DMD
DISABLE

A12: Under Voltage Alarm – 「ENABLE」 or 「DISABLE」 (Default DISABLE)

A12
UNDE
V
DISABLE

A13: Under Current Alarm – 「ENABLE」 or 「DISABLE」 (Default DISABLE)

A13
UNDE
I
DISABLE

A14: Under Frequency Alarm – 「ENABLE」 or 「DISABLE」 (Default DISABLE)

A14
UNDE
FREQ
DISABLE

A15: Over Voltage Alarm Setting from 0-600000 (Default 600000)

A15
OVER
V
SET
600000

A16: Over Voltage Alarm Condition Clear Setting from 0-600000 (Default 0)

A16
OVER
V
CLR
0000000

A17: Over Current Alarm Setting from 0-9999 (Default 9999)

A17
OVER
I
SET
9999

A18: Over Current Alarm Condition Clear Setting from 0-9999 (Default 0)

A18
OVER
I
CLR
0000

A19: Over Frequency Alarm Setting from 45-65 (Default 65)

A19
OVER
FREQ
SET
63

A20: Over Frequency Alarm Condition Clear Setting from 45-65 (Default 45)

A20
OVER
FREQ
CLR
43

A21: Over Demand Alarm Setting from 0-65535 kW (Default 65535)

A21
OVER
DMD
SET
65535

A22: Over Demand Alarm Condition Clear Setting from 0-65535 kW (Default 0)

A22
OVER
DMD
CLR
00000

A23: Under Voltage Alarm Setting from 0-600000 (Default 0)

A23
UNDE
V
SET
000000

A24: Under Voltage Alarm Condition Clear Setting from 0-600000 (Default 600000)

A24
UNDE
V
CLR
600000

A25: Under Current Alarm Setting from 0-9999 (Default 0)

A25
UNDE
I
SET
0000

A26: Under Current Alarm Condition Clear Setting from 0-9999 (Default 9999)

A26
UNDE
I
CLR
9999

A27: Under Frequency Alarm Setting from 45-65 (Default 45)

A27
UNDE
FREQ
SET
45

A28: Under Frequency Alarm Condition Clear Setting from 45-65 (Default 65)

A28
UNDE
FREQ
CLR
65

Chapter 5 Communication

5.1 RS485

5.1.1 RS485 standard

PARAMETERS	
Mode of Operation	Differential
Number of Drivers and Receives	32 Drivers / 32 Receivers
Maximum cable length(meters)	1200
Maximum data rate (baud)	10M
Maximum common mode voltage (Volts)	12 to -7
Maximum Driver Output Levels (Loaded)	+/- 1.5
Maximum Driver Output Levels (Unloaded)	+/- 6
Drive Load (Ohms)	60(min)
Driver Output short circuit Resistance (kohms)	150 to Gnd, 250 to -7 or 12V
Minimum receiver input Resistance (kohms)	12
Receiver sensitivity	+/- 200mv

5.1.2 Wiring for instruments communication

RS485 communication must use twisted paired wire, as shown in the following program. "D+" connect to one wire and "D-" to the other one

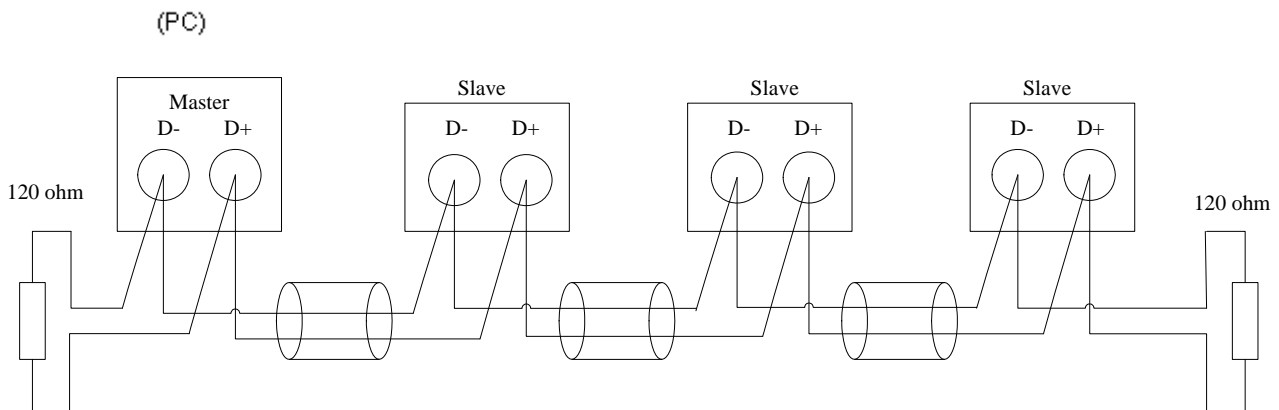

Cautions :

There must be no more than two wires connected to each terminal, this ensures that a "Daisy Chain" or "Straight Line" configuration is used. A "star" or a network with "Stubs(Tees)" is not recommended as reflections within the cable may result in data corruption.

5.2 Modbus

In the start of modbus communication, master will issue a "Query" to the slave. Every slave will monitor the "Query" address, so as to "execute" or give "response" when the address is right

5.2.1 Modbus Format

The Query-Response Cycle

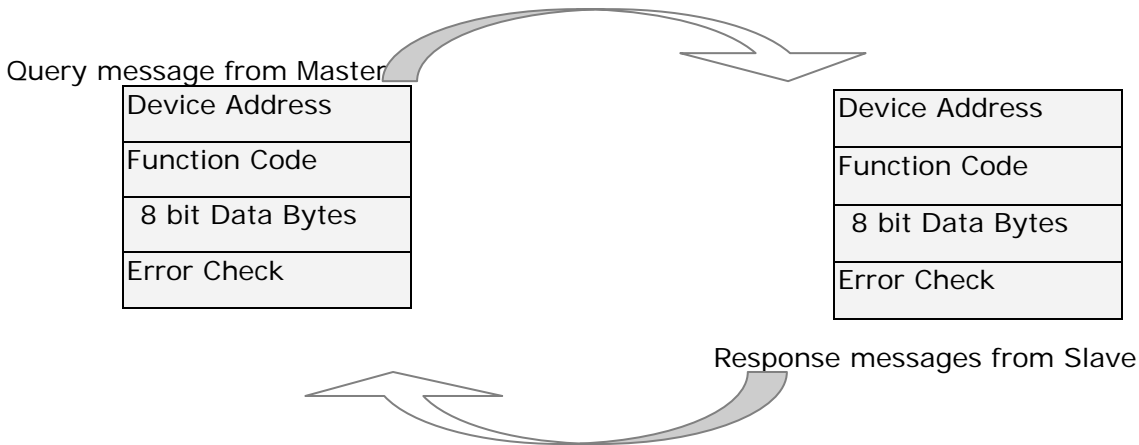
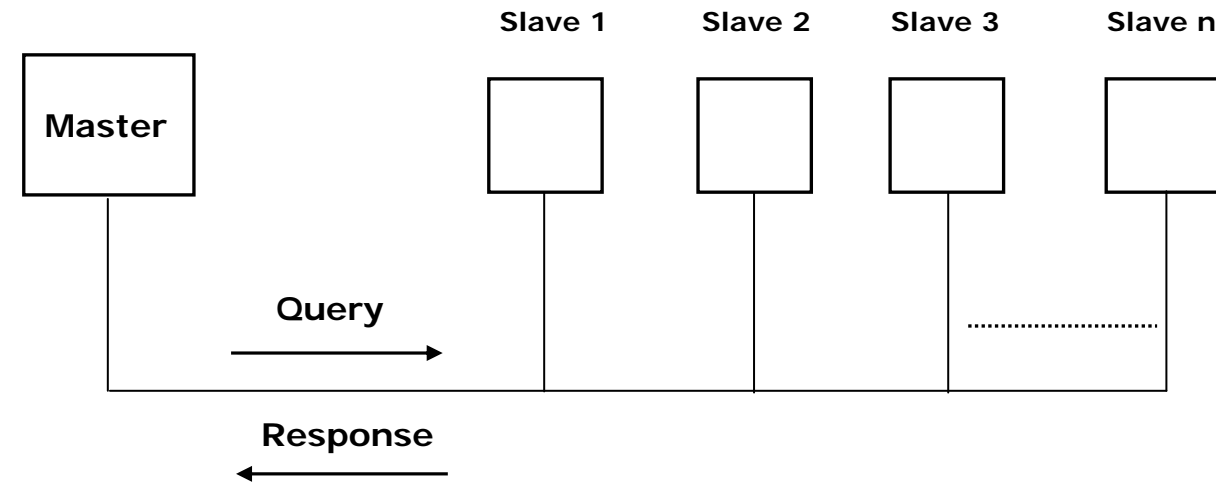

5.3 Communication protocol

IPM3300 use Modbus RTU as the communication protocol. The following shows Query and Response format.

Query :

Slave Address	Function Code 0x03, 0x04	Start Address (Hi)	Start Address (Lo)	Number of Points (Hi)	Number of Points (Lo)	Error Check (Lo)	Error Check (Hi)
---------------	--------------------------------	-----------------------	-----------------------	--------------------------	--------------------------	---------------------	---------------------

Response :

Slave Address	Function Code 0x03, 0x04	Byte Count	Data (Hi)	Data (Lo)	Error Check (Lo)	Error Check (Hi)
---------------	--------------------------------	------------	--------------	--------------	---------------------	---------------------

Query :

Slave Address	Function Code 0x10	Start Address (Hi)	Start Address (Lo)	Number of Points (Hi)	Number of Points (Lo)	Byte Count	Data (Hi)	Data (Lo)	Error Check (Lo)	Error Check (Hi)
---------------	-----------------------	--------------------	--------------------	-----------------------	-----------------------	------------	-----------	-----------	------------------	------------------

Response :

Slave Address	Function Code 0x10	Start Address (Hi)	Start Address (Lo)	Number of Points (Hi)	Number of Points (Lo)	Error Check (Lo)	Error Check (Hi)
---------------	-----------------------	--------------------	--------------------	-----------------------	-----------------------	------------------	------------------

5.4 IEEE 754 Format

The bits in an IEEE 754 format have the following significance:

Data Hi Word, Hi Byte	Data Hi Word, Lo Byte	Data Lo Word, Hi Byte	Data Lo Word, Lo Byte
SEEE EEEE	EMMM MMMM	MMMM MMMM	MMMM MMMM

Where:

S represents the sign bit where 1 is negative and 0 is positive

E is the two's complement exponent with an offset of 127, i.e. an exponent of zero is represented by 127, an exponent of 1 by 128 etc.

M is the 23-bit normal mantissa. The highest bit is always 1 and, therefore, is not stored.

For each floating point value requested two Modbus registers or points (four bytes) must be requested. The received order and significance of these four bytes for the Integral products is shown below:

Data Lo Word, Hi Byte	Data Lo Word, Lo Byte	Data Hi Word, Hi Byte	Data Hi Word, Lo Byte
-----------------------	-----------------------	-----------------------	-----------------------

5.5 Modbus RTU Mode

Since Controllers can be setup to communicate on standard Modbus networks using either of two transmission modes : **ASCII** or **RTU**. IPM3300 uses RTU transmission mode only. Users select the RTU mode, along with the serial port communication parameters(baud rate, parity mode, etc), during configuration of each controller. The mode and serial parameters must be the same for all devices on a Modbus connection.

RTU Mode

Coding System	8-bit binary, hexadecimal 0-9, A-F Two hexadecimal character contained in each 8-bit field of the message
Bits per Byte	1 start bit 8 data bits, least significant bit sent first none parity 1/2 stop bit
Error Check Field	Cyclical Redundancy Check(CRC)

5.6 Modbus Function Code

The function code of a Modbus message defines the action to be taken by the slave.

Function code use by IPM3300 is described below:

Code	Modbus name	Description
03	Read Holding Registers	Read the content of read/write location (4X reference)
04	Read Input Registers	Read the contents of read only location (3X reference)
16	Pre-set Multiple Registers	Set the contents of read/write location (4X reference)

Note: The maximum registers of Function 03 & Function 04 is 125

5.7 IPM3300 Parameter

No.	Type		Content	No. of points	R/W
1	Coil	0x0000~0x0001	Digital Output	2	R/W
2	Holding Register	0x1000~0x1001	Digital Output	2	R/W
3	Holding Register	0x1002~0x1040	Setup Parameter	63	R/W
4	Holding Register	0x1200~0x1207	Clear Function	8	W
5	Input Register	0x0000~0x000C	Realtime Data (Integer) – partial	14	R
6	Input Register	0x1000~0x0019	Realtime Data V, I, Frequency	26	R
7	Input Register	0x101A~0x1033	Realtime Data Power Result	26	R
8	Input Register	0x1034~0x1039	Energy	6	R
9	Input Register	0x103A~0x103E	Demand	5	R
10	Input Register	0x103F~0x1042	Unbalance Rate	4	R
11	Input Register	0x1043~0x1052	Voltage Eligibility Rate	16	R
12	Input Register	0x1053~0x1056	Running Hour	4	R
13	Input Register	0x1057	Alarm Flag	1	R
14	Input Register	0x1200~0x13BF	Max/Min (value & time)	448	R

Modbus Module #1 Coil Status : Digital Output

Parameter name	Modbus Register	Comment
Digital Output 1	00000	for function code 01: Read Coil Status & 05 : Force Single Coil
Digital Output 2	00001	for function code 01: Read Coil Status & 05 : Force Single Coil

Modbus Module #2 Holding Register : Digital Output

Parameter name	Modbus Register		Len	Data Type	Range	Default value	Units	Comment
	Modicom Format	Hex						
Digital Output	44097	0x1000	Word	UInt	bit 0 : Digital Output 1 bit 1 : Digital Output 2	0		
Digital_Output_Reserved	44098	0x1001	Word	UInt				

Modbus Module #3 Holding Register : Setup Parameter

Parameter name	Modbus Register		Len	Data Type	Range	Default value	Units	Comment
	Modicom Format	Hex						
Comm_485_Address	44099	0x1002	Word	UInt	1-255	15		
Comm_485_BaudRate	44100	0x1003	Word	UInt	0: 4800, 1: 9600 , 2: 19200, 3: 38400 4: 57600	2	bps	
Comm_485_StopBit	44101	0x1004	Word	UInt	0: 1 Stop bit, 1: 2 Stop bit	0		
Wiring_Mode	44102	0x1005	Word	UInt	0: 1P2W, 1: 1P3W, 2: 3P3W-2CT, 3: 3P3W-3CT, 4: 3P4W-Y 5: Auto	5		
PT_Primary	44103-44104	0x1006-0x1007	DWord	UInt32	60-600000	110	Volt	
PT_Secondary	44105	0x1008	Word	UInt	1-600	110	Volt	
CT_Primary	44106	0x1009	Word	UInt	1-5000	1	Amp.	
CT_Secondary	44107	0x100A	Word	UInt	1-5	1	Amp.	
Back_Light_Timeout	44108	0x100B	Word	UInt	0-120	1	min	

Brightness	44109	0x100C	Word	UInt	0-4	3		
I1_Flow	44110	0x100D	Word	UInt	0: Positive 1: Negative	0		

I2_Flow	44111	0x100E	Word	UInt	0: Positive 1: Negative	0		
I3_Flow	44112	0x100F	Word	UInt	0: Positive 1: Negative	0		
V1_Up_Limit	44113	0x1010	Word	UInt	0-65535	65535	0.1V	Secondary
V1_Low_Limit	44114	0x1011	Word	UInt	0-65535	0	0.1V	Secondary
V2_Up_Limit	44115	0x1012	Word	UInt	0-65535	65535	0.1V	Secondary
V2_Low_Limit	44116	0x1013	Word	UInt	0-65535	0	0.1V	Secondary
V3_Up_Limit	44117	0x1014	Word	UInt	0-65535	65535	0.1V	Secondary
V3_Low_Limit	44118	0x1015	Word	UInt	0-65535	0	0.1V	Secondary
Demand_mode	44119	0x1016	Word	UInt	0: Block, 1: Rolling	0		
Number_of_Subinterval	44120	0x1017	Word	UInt	1,2,3,4,5,6,10	1		
Subinterval_Length	44121	0x1018	Word	UInt	1,2,3,4,5,6,10,12, 15,20,30,60	15	min	
Year	44122	0x1019	Word	BCD				
Month	44123	0x101A	Word	BCD				
Date	44124	0x101B	Word	BCD				
Hour	44125	0x101C	Word	BCD				
Min	44126	0x101D	Word	BCD				
Second	44127	0x101E	Word	BCD				
Password	44128	0x101F	Word	UInt	0x0000-0xFFFF	0x0000		
Alarm_Enable	44129	0x1020	Word	UInt	0: OFF, 1: ON	0		
Buzzer_Enable	44130	0x1021	Word	UInt	0: OFF, 1: ON	0		
DO1_Alarm_Item	44131	0x1022	Word	UInt	0: None 1: Any 2: Over Voltage 3: Over Current 4: Over Frequency 5: Over Demand 6: Under Voltage 7: Under Current 8: Under Frequency	0		
DO2_Function	44132	0x1023	Word	UInt	0: Pulse Output 1: Alarm Output	0		
DO2_Alarm_Item	44133	0x1024	Word	UInt	0: None 1: Any 2: Over Voltage 3: Over Current 4: Over Frequency 5: Over Demand 6: Under Voltage 7: Under Current 8: Under Frequency	0		
DO2_Pulse_Item	44134	0x1025	Word	UInt	0: None, 1: kWh 2: kvarh, 3: kVAh	0		
DO2_Pulse_kh	44135	0x1026	Word	UInt	1-6000	10	0.1 kWh	
Over_Voltage_Enable	44136	0x1027	Word	UInt	0: Disable 1: Enable	0		
Over_Current_Enable	44137	0x1028	Word	UInt	0: Disable 1: Enable	0		
Over_Frequency_Enable	44138	0x1029	Word	UInt	0: Disable 1: Enable	0		
Over_Demand_Enable	44139	0x102A	Word	UInt	0: Disable 1: Enable	0		
Under_Voltage_Enable	44140	0x102B	Word	UInt	0: Disable 1: Enable	0		
Under_Current_Enable	44141	0x102C	Word	UInt	0: Disable 1: Enable	0		
Under_Frequency_Enable	44142	0x102D	Word	UInt	0: Disable 1: Enable	0		
Over_Voltage_Set_Point	44143-44144	0x102E-0x102F	DWord	UInt32	0-600000	600000	Volt	
Over_Voltage_Clear_Point	44145-44146	0x1030-0x1031	DWord	UInt32	0-600000	0	Volt	

Over_Current_Set_Point	44147	0x1032	Word	UInt	0-9999	9999	Amp	
Over_Current_Clear_Point	44148	0x1033	Word	UInt	0-9999	0	Amp	
Over_Frequency_Set_Point	44149	0x1034	Word	UInt	45-65	65	Hz	
Over_Frequency_Clear_Point	44150	0x1035	Word	UInt	45-65	45	Hz	

Over_Demand_Set_Point	44151	0x1036	Word	UInt	0-65535	65535	kW	
Over_Demand_Clear_Point	44152	0x1037	Word	UInt	0-65535	0	kW	
Under_Voltage_Set_Point	44153-44154	0x1038-0x1039	DWord	UInt32	0-600000	0	Volt	
Under_Voltage_Clear_Point	44155-44156	0x103A-0x103B	DWord	UInt32t	0-600000	600000	Volt	
Under_Current_Set_Point	44157	0x103C	Word	UInt	0-9999	0	Amp	
Under_Current_Clear_Point	44158	0x103D	Word	UInt	0-9999	9999	Amp	
Under_Frequency_Set_Point	44159	0x103E	Word	UInt	45-65	45	Hz	
Under_Frequency_Clear_Point	44160	0x103F	Word	UInt	45-65	65	Hz	
FWVersion	44161	0x1040	Word	UInt				read only

Modbus Module #4 Holding Register : Clear Function

Parameter name	Modbus Register		Len	Data Type	Range	Default value	Units	Comment
	Modicom Format	Hex						
Reset_Energy	44609	0x1200	Word	UInt	0x5aa5	0		0x5aa5: clear
Reset_All	44610	0x1201	Word	UInt	0x5aa5	0		0x5aa5: clear
Reset_Meter_Running_Hour	44611	0x1202	Word	UInt	0x5aa5	0		0x5aa5: clear
Reset_Load_Running_Hour	44612	0x1203	Word	UInt	0x5aa5	0		0x5aa5: clear
Demand_Reset	44613	0x1204	Word	UInt	0x5aa5	0		0x5aa5: clear
Period_Reset	44614	0x1205	Word	UInt	0x5aa5	0		0x5aa5: clear
Reset_To_Default	44615	0x1206	Word	UInt	0x5aa5	0		0x5aa5: clear
Reset_Voltage_Eligibility	44616	0x1207	Word	UInt	0x5aa5	0		0x5aa5: clear

Modbus Module #5 Input Register : Realtime Data (Integer)

Parameter name	Modbus Register		Len	Data Type	Range	Units	Comment
	Modicom Format	Hex					
R(R-S) voltage	30001	0x0000	Word	UInt	0-65535	0.1 Volt	0-6553.5V
S(S-T) voltage	30002	0x0001	Word	UInt	0-65535	0.1 Volt	0-6553.5V
T(T-R) voltage	30003	0x0002	Word	UInt	0-65535	0.1 Volt	0-6553.5V
R current	30004	0x0003	Word	UInt	0-65535	0.1A	0-6553.5A
S current	30005	0x0004	Word	UInt	0-65535	0.1A	0-6553.5A
T current	30006	0x0005	Word	UInt	0-65535	0.1A	0-6553.5A
Frequency	30007	0x0006	Word	UInt	0-999	0.1Hz	0-99.9Hz
PF.	30008	0x0007	Word	Int	-1000~ +1000	0.001Pf	-1.000~1.000
kW	30009	0x0008	Word	UInt	0-65535	0.1kW	0-6553.5kW
kvar	30010	0x0009	Word	UInt	0-65535	0.1kvar	0-6553.5kvar
kWH	30011-30012	0x0009-0x000A	DWord	UInt32	0-999999999	0.1kWh	0-99999999.9
kVArh	30013-30014	0x000B-0x000C	DWord	UInt32	0-999999999	0.1kvarh	0-99999999.9

Modbus Module #6 Input Register : Realtime Data Voltage, Current, Frequency (Float)

Parameter name	Modbus Register		Len	Data Type	Range	Units	Comment
	Modicom Format	Hex					
VIn_a	34097-34098	0x1000-0x1001	DWord	Float		Volt	Primary
VIn_b	34099-34100	0x1002-0x1003	DWord	Float		Volt	Primary
VIn_c	34101-34102	0x1004-0x1005	DWord	Float		Volt	Primary
VIn_avg	34103-34104	0x1006-0x1007	DWord	Float		Volt	Primary
VII_ab	34105-34106	0x1008-0x1009	DWord	Float		Volt	Primary

VII_bc	34107-34108	0x100A-0x100B	DWord	Float		Volt	Primary
VII_ca	34109-34110	0x100C-0x100D	DWord	Float		Volt	Primary
VII_avg	34111-34112	0x100E-0x100F	DWord	Float		Volt	Primary
I_a	34113-34114	0x1010-0x1011	DWord	Float		Amp.	Primary
I_b	34115-34116	0x1012-0x1013	DWord	Float		Amp.	Primary
I_c	34117-34118	0x1014-0x1015	DWord	Float		Amp.	Primary
I_avg	34119-34120	0x1016-0x1017	DWord	Float		Amp.	Primary
Frequency	34121-34122	0x1018-0x1019	DWord	Float		Hz	

Modbus Module #7 Input Register : Realtime Data Power Result (Float)

Parameter name	Modbus Register		Len	Data Type	Range	Units	Comment
	Modicom Format	Hex					
kW_a	34123-34124	0x101A-0x101B	DWord	Float		kW	Primary
kW_b	34125-34126	0x101C-0x101D	DWord	Float		kW	Primary
kW_c	34127-34128	0x101E-0x101F	DWord	Float		kW	Primary
kW_tot	34129-34130	0x1020-0x1021	DWord	Float		kW	Primary
kvar_a	34131-34132	0x1022-0x1023	DWord	Float		kvar	Primary
kvar_b	34133-34134	0x1024-0x1025	DWord	Float		kvar	Primary
kvar_c	34135-34136	0x1026-0x1027	DWord	Float		kvar	Primary
kvar_tot	34137-34138	0x1028-0x1029	DWord	Float		kvar	Primary
kVA_a	34139-34140	0x102A-0x102B	DWord	Float		kVA	Primary
kVA_b	34141-34142	0x102C-0x102D	DWord	Float		kVA	Primary
kVA_c	34143-34144	0x102E-0x102F	DWord	Float		kVA	Primary
kVA_tot	34145-34146	0x1030-0x1031	DWord	Float		kVA	Primary
PF	34147-34148	0x1032-0x1033	DWord	Float			

Modbus Module #8 Input Register : Energy (Float)

Parameter name	Modbus Register		Len	Data Type	Range	Units	Comment
	Modicom Format	Hex					
kWh	34149-34150	0x1034-0x1035	DWord	Float			

kvarh	34151-34152	0x1036-0x1037	DWord	Float			
kVAh	34153-34154	0x1038-0x1039	DWord	Float			

Modbus Module #9 Input Register : Realtime data Demand

Parameter name	Modbus Register		Len	Data Type	Range	Units	Comment
	Modicom Format	Hex					
Demand_kW_Pre_Period	34155-34156	0x103A-0x103B	DWord	Float		kW	Primary
Demand_kW	34157-34158	0x103C-0x103D	DWord	Float		kW	Primary
Demand_Remain_Time	34159	0x103E	Word	UInt		sec	

Modbus Module #10 Input Register : Unbalance Rate

Parameter name	Modbus Register		Len	Data Type	Range	Units	Comment
	Modicom Format	Hex					
V_Unbalance_Rate	34160-34161	0x103F-0x1040	DWord	Float		%	
I_Unbalance_Rate	34162-34163	0x1041-0x1042	DWord	Float		%	

Modbus Module #11 Input Register : Voltage Eligibility Rate

Parameter name	Modbus Register		Len	Data Type	Range	Units	Comment
	Modicom Format	Hex					
Va_Eligibility_Rate	34164-34165	0x1043-0x1044	DWord	Float		%	
Vb_Eligibility_Rate	34166-34167	0x1045-0x1046	DWord	Float		%	
Vc_Eligibility_Rate	34168-34169	0x1047-0x1048	DWord	Float		%	
Vavg_Eligibility_Rate	34170-34171	0x1049-0x104A	DWord	Float		%	
Va Eligible Running Hour	34172-34173	0x104B-0x104C	DWord	UInt32	0-360000000	sec	up to 100000 hr
Vb Eligible Running Hour	34174-34175	0x104D-0x104E	DWord	UInt32	0-360000000	sec	up to 100000 hr
Vc Eligible Running Hour	34176-34177	0x104F-0x1050	DWord	UInt32	0-360000000	sec	up to 100000 hr
V Eligible total check Running Hours	34178-34179	0x1051-0x1052	DWord	UInt32	0-360000000	sec	up to 100000 hr

Modbus Module #12 Input Register : Running Hour

Parameter name	Modbus Register		Len	Data Type	Range	Units	Comment
	Modicom Format	Hex					
Load Running Hour	34180-34181	0x1053-0x1054	DWord	UInt32	0-360000000	sec	up to 100000 hr
Meter Running Hour	34180-34181	0x1055-0x1056	DWord	UInt32	0-360000000	sec	up to 100000 hr

Modbus Module #13 Input Register : Alarm Flag

Parameter name	Modbus Register		Len	Data Type	Range	Units	Comment
	Modicom Format	Hex					
Alarm Flag	34182	0x1057	Word	UInt	bit 0: Over Voltage 1: Over Current 2: Over Frequency 3: Over Demand 4: Under Voltage 5: Under Current 6: Under Frequency	bit	0 : Disable 1 : Enable

Modbus Module #14 Input Register : Max/Min Data

Parameter name	Modbus Register		Len	Data Type	Range	Units	Comment
	Modicom Format	Hex					
Va_max	34609-34610	0x1200-0x1201	DWord	Float		Volt	
Va_max_Year	34611	0x1202	Word	BCD	00-99		
Va_max_Month	34612	0x1203	Word	BCD	1-12		
Va_max_Date	34613	0x1204	Word	BCD	1-31		
Va_max_Hour	34614	0x1205	Word	BCD	0-23		
Va_max_Min	34615	0x1206	Word	BCD	0-59		
Va_max_Second	34616	0x1207	Word	BCD	0-59		
Va_min	34617-34618	0x1208-0x1209	DWord	Float		Volt	
Va_min_Year	34619	0x120A	Word	BCD	00-99		
Va_min_Month	34620	0x120B	Word	BCD	1-12		
Va_min_Date	34621	0x120C	Word	BCD	1-31		

Va_min_Hour	34622	0x120D	Word	BCD	0-23		
Va_min_Min	34623	0x120E	Word	BCD	0-59		
Va_min_Second	34624	0x120F	Word	BCD	0-59		
Vb_max	34625-34626	0x1210-0x1211	DWord	Float		Volt	
Vb_max_Year	34627	0x1212	Word	BCD	00-99		
Vb_max_Month	34628	0x1213	Word	BCD	1-12		
Vb_max_Date	34629	0x1214	Word	BCD	1-31		
Vb_max_Hour	34630	0x1215	Word	BCD	0-23		
Vb_max_Min	34631	0x1216	Word	BCD	0-59		
Vb_max_Second	34632	0x1217	Word	BCD	0-59		
Vb_min	34633-34634	0x1218-0x1219	DWord	Float		Volt	
Vb_min_Year	34635	0x121A	Word	BCD	00-99		
Vb_min_Month	34636	0x121B	Word	BCD	1-12		
Vb_min_Date	34637	0x121C	Word	BCD	1-31		
Vb_min_Hour	34638	0x121D	Word	BCD	0-23		
Vb_min_Min	34639	0x121E	Word	BCD	0-59		
Vb_min_Second	34640	0x121F	Word	BCD	0-59		
Vc_max	34641-34642	0x1220-0x1221	DWord	Float		Volt	
Vc_max_Year	34643	0x1222	Word	BCD	00-99		
Vc_max_Month	34644	0x1223	Word	BCD	1-12		
Vc_max_Date	34645	0x1224	Word	BCD	1-31		
Vc_max_Hour	34646	0x1225	Word	BCD	0-23		
Vc_max_Min	34647	0x1226	Word	BCD	0-59		
Vc_max_Second	34648	0x1227	Word	BCD	0-59		
Vc_min	34649-34650	0x1228-0x1229	DWord	Float		Volt	
Vc_min_Year	34651	0x122A	Word	BCD	00-99		
Vc_min_Month	34652	0x122B	Word	BCD	1-12		
Vc_min_Date	34653	0x122C	Word	BCD	1-31		
Vc_min_Hour	34654	0x122D	Word	BCD	0-23		
Vc_min_Min	34655	0x122E	Word	BCD	0-59		
Vc_min_Second	34656	0x122F	Word	BCD	0-59		
Vlnavg_max	34657-34658	0x1230-0x1231	DWord	Float		Volt	
Vlnavg_max_Year	34659	0x1232	Word	BCD	00-99		
Vlnavg_max_Month	34660	0x1233	Word	BCD	1-12		

Vlnavg_max_Date	34661	0x1234	Word	BCD	1-31		
Vlnavg_max_Hour	34662	0x1235	Word	BCD	0-23		
Vlnavg_max_Min	34663	0x1236	Word	BCD	0-59		
Vlnavg_max_Second	34664	0x1237	Word	BCD	0-59		
Vlnavg_min	34665-34666	0x1238-0x1239	DWord	Float		Volt	
Vlnavg_min_Year	34667	0x123A	Word	BCD	00-99		
Vlnavg_min_Month	34668	0x123B	Word	BCD	1-12		
Vlnavg_min_Date	34669	0x123C	Word	BCD	1-31		
Vlnavg_min_Hour	34670	0x123D	Word	BCD	0-23		
Vlnavg_min_Min	34671	0x123E	Word	BCD	0-59		
Vlnavg_min_Second	34672	0x123F	Word	BCD	0-59		
Vab_max	34673-34674	0x1240-0x1241	DWord	Float		Volt	
Vab_max_Year	34675	0x1242	Word	BCD	00-99		
Vab_max_Month	34676	0x1243	Word	BCD	1-12		
Vab_max_Date	34677	0x1244	Word	BCD	1-31		
Vab_max_Hour	34678	0x1245	Word	BCD	0-23		
Vab_max_Min	34679	0x1246	Word	BCD	0-59		
Vab_max_Second	34680	0x1247	Word	BCD	0-59		
Vab_min	34681-34682	0x1248-0x1249	DWord	Float		Volt	
Vab_min_Year	34683	0x124A	Word	BCD	00-99		
Vab_min_Month	34684	0x124B	Word	BCD	1-12		
Vab_min_Date	34685	0x124C	Word	BCD	1-31		
Vab_min_Hour	34686	0x124D	Word	BCD	0-23		
Vab_min_Min	34687	0x124E	Word	BCD	0-59		
Vab_min_Second	34688	0x124F	Word	BCD	0-59		
Vbc_max	34689-34690	0x1250-0x1251	DWord	Float		Volt	

V.bc_max_Year	34691	0x1252	Word	BCD	00-99		
Vbc_max_Month	34692	0x1253	Word	BCD	1-12		
Vbc_max_Date	34693	0x1254	Word	BCD	1-31		
Vbc_max_Hour	34694	0x1255	Word	BCD	0-23		
Vbc_max_Min	34695	0x1256	Word	BCD	0-59		
Vbc_max_Second	34696	0x1257	Word	BCD	0-59		
Vbc_min	34697-34698	0x1258-0x1259	DWord	Float		Volt	
Vbc_min_Year	34699	0x125A	Word	BCD	00-99		
Vbc_min_Month	34700	0x125B	Word	BCD	1-12		
Vbc_min_Date	34701	0x125C	Word	BCD	1-31		
Vbc_min_Hour	34702	0x125D	Word	BCD	0-23		
Vbc_min_Min	34703	0x125E	Word	BCD	0-59		
Vbc_min_Second	34704	0x125F	Word	BCD	0-59		
Vca_max	34705-34706	0x1260-0x1261	DWord	Float		Volt	
Vca_max_Year	34707	0x1262	Word	BCD	00-99		
Vca_max_Month	34708	0x1263	Word	BCD	1-12		
Vca_max_Date	34709	0x1264	Word	BCD	1-31		
Vca_max_Hour	34710	0x1265	Word	BCD	0-23		
Vca_max_Min	34711	0x1266	Word	BCD	0-59		
Vca_max_Second	34712	0x1267	Word	BCD	0-59		
Vca_min	34713-34714	0x1268-0x1269	DWord	Float		Volt	
Vca_min_Year	34715	0x126A	Word	BCD	00-99		
Vca_min_Month	34716	0x126B	Word	BCD	1-12		
Vca_min_Date	34717	0x126C	Word	BCD	1-31		
Vca_min_Hour	34718	0x126D	Word	BCD	0-23		
Vca_min_Min	34719	0x126E	Word	BCD	0-59		
Vca_min_Second	34720	0x126F	Word	BCD	0-59		
Vllavg_max	34721-34722	0x1270-0x1271	DWord	Float		Volt	
Vllavg_max_Year	34723	0x1272	Word	BCD	00-99		
Vllavg_max_Month	34724	0x1273	Word	BCD	1-12		
Vllavg_max_Date	34725	0x1274	Word	BCD	1-31		

Vllavg_max_Hour	34726	0x1275	Word	BCD	0-23		
Vllavg_max_Min	34727	0x1276	Word	BCD	0-59		
Vllavg_max_Second	34728	0x1277	Word	BCD	0-59		
Vllavg_min	34729-34730	0x1278-0x1279	DWord	Float		Volt	
Vllavg_min_Year	34731	0x127A	Word	BCD	00-99		
Vllavg_min_Month	34732	0x127B	Word	BCD	1-12		
Vllavg_min_Date	34733	0x127C	Word	BCD	1-31		
Vllavg_min_Hour	34734	0x127D	Word	BCD	0-23		
Vllavg_min_Min	34735	0x127E	Word	BCD	0-59		
Vllavg_min_Second	34736	0x127F	Word	BCD	0-59		
Ia_max	34737-34738	0x1280-0x1281	DWord	Float		Amp	
Ia_max_Year	34739	0x1282	Word	BCD	00-99		
Ia_max_Month	34740	0x1283	Word	BCD	1-12		
Ia_max_Date	34741	0x1284	Word	BCD	1-31		
Ia_max_Hour	34742	0x1285	Word	BCD	0-23		
Ia_max_Min	34743	0x1286	Word	BCD	0-59		
Ia_max_Second	34744	0x1287	Word	BCD	0-59		
Ia_min	34745-34746	0x1288-0x1289	DWord	Float		Amp	
Ia_min_Year	34747	0x128A	Word	BCD	00-99		
Ia_min_Month	34748	0x128B	Word	BCD	1-12		
Ia_min_Date	34749	0x128C	Word	BCD	1-31		
Ia_min_Hour	34750	0x128D	Word	BCD	0-23		
Ia_min_Min	34751	0x128E	Word	BCD	0-59		
Ia_min_Second	34752	0x128F	Word	BCD	0-59		
Ib_max	34753-34754	0x1290-0x1291	DWord	Float		Amp	
Ib_max_Year	34755	0x1292	Word	BCD	00-99		
Ib_max_Month	34756	0x1293	Word	BCD	1-12		
Ib_max_Date	34757	0x1294	Word	BCD	1-31		
Ib_max_Hour	34758	0x1295	Word	BCD	0-23		
Ib_max_Min	34759	0x1296	Word	BCD	0-59		

Ib_max_Second	34760	0x1297	Word	BCD	0-59		
Ib_min	34761-34762	0x1298-0x1299	DWord	Float		Amp	
Ib_min_Year	34763	0x129A	Word	BCD	00-99		
Ib_min_Month	34764	0x129B	Word	BCD	1-12		
Ib_min_Date	34765	0x129C	Word	BCD	1-31		
Ib_min_Hour	34766	0x129D	Word	BCD	0-23		
Ib_min_Min	34767	0x129E	Word	BCD	0-59		
Ib_min_Second	34768	0x129F	Word	BCD	0-59		
Ic_max	34769-34770	0x12A0-0x12A1	DWord	Float		Amp	
Ic_max_Year	34771	0x12A2	Word	BCD	00-99		
Ic_max_Month	34772	0x12A3	Word	BCD	1-12		
Ic_max_Date	34773	0x12A4	Word	BCD	1-31		
Ic_max_Hour	34774	0x12A5	Word	BCD	0-23		
Ic_max_Min	34775	0x12A6	Word	BCD	0-59		
Ic_max_Second	34776	0x12A7	Word	BCD	0-59		
Ic_min	34777-34778	0x12A8-0x12A9	DWord	Float		Amp	
Ic_min_Year	34779	0x12AA	Word	BCD	00-99		
Ic_min_Month	34780	0x12AB	Word	BCD	1-12		
Ic_min_Date	34781	0x12AC	Word	BCD	1-31		
Ic_min_Hour	34782	0x12AD	Word	BCD	0-23		
Ic_min_Min	34783	0x12AE	Word	BCD	0-59		
Ic_min_Second	34784	0x12AF	Word	BCD	0-59		
Iavg_max	34785-34786	0x12B0-0x12B1	DWord	Float		Amp	
Iavg_max_Year	34787	0x12B2	Word	BCD	00-99		
Iavg_max_Month	34788	0x12B3	Word	BCD	1-12		
Iavg_max_Date	34789	0x12B4	Word	BCD	1-31		
Iavg_max_Hour	34790	0x12B5	Word	BCD	0-23		
Iavg_max_Min	34791	0x12B6	Word	BCD	0-59		

lavg_max_Second	34792	0x12B7	Word	BCD	0-59		
lavg_min	34793-34794	0x12B8-0x12B9	DWord	Float		Amp	
lavg_min_Year	34795	0x12BA	Word	BCD	00-99		
lavg_min_Month	34796	0x12BB	Word	BCD	1-12		
lavg_min_Date	34797	0x12BC	Word	BCD	1-31		
lavg_min_Hour	34798	0x12BD	Word	BCD	0-23		
lavg_min_Min	34799	0x12BE	Word	BCD	0-59		
lavg_min_Second	34800	0x12BF	Word	BCD	0-59		
kWa_max	34801-34802	0x12C0-0x12C1	DWord	Float			
kWa_max_Year	34803	0x12C2	Word	BCD	00-99		
kWa_max_Month	34804	0x12C3	Word	BCD	1-12		
kWa_max_Date	34805	0x12C4	Word	BCD	1-31		
kWa_max_Hour	34806	0x12C5	Word	BCD	0-23		
kWa_max_Min	34807	0x12C6	Word	BCD	0-59		
kWa_max_Second	34808	0x12C7	Word	BCD	0-59		
kWa_min	34809-34810	0x12C8-0x12C9	DWord	Float			
kWa_min_Year	34811	0x12CA	Word	BCD	00-99		
kWa_min_Month	34812	0x12CB	Word	BCD	1-12		
kWa_min_Date	34813	0x12CC	Word	BCD	1-31		
kWa_min_Hour	34814	0x12CD	Word	BCD	0-23		
kWa_min_Min	34815	0x12CE	Word	BCD	0-59		
kWa_min_Second	34816	0x12CF	Word	BCD	0-59		
kWb_max	34817-34818	0x12D0-0x12D1	DWord	Float			
kWb_max_Year	34819	0x12D2	Word	BCD	00-99		
kWb_max_Month	34820	0x12D3	Word	BCD	1-12		
kWb_max_Date	34821	0x12D4	Word	BCD	1-31		
kWb_max_Hour	34822	0x12D5	Word	BCD	0-23		
kWb_max_Min	34823	0x12D6	Word	BCD	0-59		
kWb_max_Second	34824	0x12D7	Word	BCD	0-59		
kWb_min	34825-34826	0x12D8-0x12D9	DWord	Float			
kWb_min_Year	34827	0x12DA	Word	BCD	00-99		
kWb_min_Month	34828	0x12DB	Word	BCD	1-12		

kWb_min_Date	34829	0x12DC	Word	BCD	1-31		
kWb_min_Hour	34830	0x12DD	Word	BCD	0-23		
kWb_min_Min	34831	0x12DE	Word	BCD	0-59		
kWb_min_Second	34832	0x12DF	Word	BCD	0-59		
kWc_max	34833-34834	0x12E0-0x12E1	DWord	Float			
kWc_max_Year	34835	0x12E2	Word	BCD	00-99		
kWc_max_Month	34836	0x12E3	Word	BCD	1-12		
kWc_max_Date	34837	0x12E4	Word	BCD	1-31		
kWc_max_Hour	34838	0x12E5	Word	BCD	0-23		
kWc_max_Min	34839	0x12E6	Word	BCD	0-59		
kWc_max_Second	34840	0x12E7	Word	BCD	0-59		
kWc_min	34841-34842	0x12E8-0x12E9	DWord	Float			
kWc_min_Year	34843	0x12EA	Word	BCD	00-99		
kWc_min_Month	34844	0x12EB	Word	BCD	1-12		
kWc_min_Date	34845	0x12EC	Word	BCD	1-31		
kWc_min_Hour	34846	0x12ED	Word	BCD	0-23		
kWc_min_Min	34847	0x12EE	Word	BCD	0-59		
kWc_min_Second	34848	0x12EF	Word	BCD	0-59		
kWtot_max	34849-34850	0x12F0-0x12F1	DWord	Float			
kWtot_max_Year	34851	0x12F2	Word	BCD	00-99		
kWtot_max_Month	34852	0x12F3	Word	BCD	1-12		
kWtot_max_Date	34853	0x12F4	Word	BCD	1-31		
kWtot_max_Hour	34854	0x12F5	Word	BCD	0-23		
kWtot_max_Min	34855	0x12F6	Word	BCD	0-59		

kWtot_max_Second	34856	0x12F7	Word	BCD	0-59		
kWtot_min	34857-34858	0x12F8-0x12F9	DWord	Float			
kWtot_min_Year	34859	0x12FA	Word	BCD	00-99		
kWtot_min_Month	34860	0x12FB	Word	BCD	1-12		
kWtot_min_Date	34861	0x12FC	Word	BCD	1-31		
kWtot_min_Hour	34862	0x12FD	Word	BCD	0-23		
kWtot_min_Min	34863	0x12FE	Word	BCD	0-59		
kWtot_min_Second	34864	0x12FF	Word	BCD	0-59		
kvara_max	34865-34866	0x1300-0x1301	DWord	Float			
kvara_max_Year	34867	0x1302	Word	BCD	00-99		
kvara_max_Month	34868	0x1303	Word	BCD	1-12		
kvara_max_Date	34869	0x1304	Word	BCD	1-31		
kvara_max_Hour	34870	0x1305	Word	BCD	0-23		
kvara_max_Min	34871	0x1306	Word	BCD	0-59		
kvara_max_Second	34872	0x1307	Word	BCD	0-59		
kvara_min	34873-34874	0x1308-0x1309	DWord	Float			
kvara_min_Year	34875	0x130A	Word	BCD	00-99		
kvara_min_Month	34876	0x130B	Word	BCD	1-12		
kvara_min_Date	34877	0x130C	Word	BCD	1-31		
kvara_min_Hour	34878	0x130D	Word	BCD	0-23		
kvara_min_Min	34879	0x130E	Word	BCD	0-59		
kvara_min_Second	34880	0x130F	Word	BCD	0-59		
kvarb_max	34881-34882	0x1310-0x1311	DWord	Float			
kvarb_max_Year	34883	0x1312	Word	BCD	00-99		
kvarb_max_Month	34884	0x1313	Word	BCD	1-12		
kvarb_max_Date	34885	0x1314	Word	BCD	1-31		
kvarb_max_Hour	34886	0x1315	Word	BCD	0-23		
kvarb_max_Min	34887	0x1316	Word	BCD	0-59		
kvarb_max_Second	34888	0x1317	Word	BCD	0-59		
kvarb_min	34889-34890	0x1318-0x1319	DWord	Float			
kvarb_min_Year	34891	0x131A	Word	BCD	00-99		
kvarb_min_Month	34892	0x131B	Word	BCD	1-12		
kvarb_min_Date	34893	0x131C	Word	BCD	1-31		
kvarb_min_Hour	34894	0x131D	Word	BCD	0-23		
kvarb_min_Min	34895	0x131E	Word	BCD	0-59		
kvarb_min_Second	34896	0x131F	Word	BCD	0-59		

kvarc_max	34897-34898	0x1320-0x1321	DWord	Float			
kvarc_max_Year	34899	0x1322	Word	BCD	00-99		
kvarc_max_Month	34900	0x1323	Word	BCD	1-12		
kvarc_max_Date	34901	0x1324	Word	BCD	1-31		
kvarc_max_Hour	34902	0x1325	Word	BCD	0-23		
kvarc_max_Min	34903	0x1326	Word	BCD	0-59		
kvarc_max_Second	34904	0x1327	Word	BCD	0-59		
kvarc_min	34905-34906	0x1328-0x1329	DWord	Float			
kvarc_min_Year	34907	0x132A	Word	BCD	00-99		
kvarc_min_Month	34908	0x132B	Word	BCD	1-12		
kvarc_min_Date	34909	0x132C	Word	BCD	1-31		
kvarc_min_Hour	34910	0x132D	Word	BCD	0-23		
kvarc_min_Min	34911	0x132E	Word	BCD	0-59		
kvara_min_Second	34912	0x132F	Word	BCD	0-59		
kvar_tot_max	34913-34914	0x1330-0x1331	DWord	Float			
kvar_tot_max_Year	34915	0x1332	Word	BCD	00-99		
kvar_tot_max_Month	34916	0x1333	Word	BCD	1-12		
kvar_tot_max_Date	34917	0x1334	Word	BCD	1-31		
kvar_tot_max_Hour	34918	0x1335	Word	BCD	0-23		
kvar_tot_max_Min	34919	0x1336	Word	BCD	0-59		
kvar_tot_max_Second	34920	0x1337	Word	BCD	0-59		

kVartot_min	34921-34922	0x1338-0x1339	DWord	Float			
kVartot_min_Year	34923	0x133A	Word	BCD	00-99		
kVartot_min_Month	34924	0x133B	Word	BCD	1-12		
kVartot_min_Date	34925	0x133C	Word	BCD	1-31		
kVartot_min_Hour	34926	0x133D	Word	BCD	0-23		
kVartot_min_Min	34927	0x133E	Word	BCD	0-59		
kVartot_min_Second	34928	0x133F	Word	BCD	0-59		
kVAa_max	34929-34930	0x1340-0x1341	DWord	Float			
kVAa_max_Year	34931	0x1342	Word	BCD	00-99		
kVAa_max_Month	34932	0x1343	Word	BCD	1-12		
kVAa_max_Date	34933	0x1344	Word	BCD	1-31		
kVAa_max_Hour	34934	0x1345	Word	BCD	0-23		
kVAa_max_Min	34935	0x1346	Word	BCD	0-59		
kVAa_max_Second	34936	0x1347	Word	BCD	0-59		
kVAa_min	34937-34938	0x1348-0x1349	DWord	Float			
kVAa_min_Year	34939	0x134A	Word	BCD	00-99		
kVAa_min_Month	34940	0x134B	Word	BCD	1-12		
kVAa_min_Date	34941	0x134C	Word	BCD	1-31		
kVAa_min_Hour	34942	0x134D	Word	BCD	0-23		
kVAa_min_Min	34943	0x134E	Word	BCD	0-59		
kVAa_min_Second	34944	0x134F	Word	BCD	0-59		
kVAb_max	34945-34946	0x1350-0x1351	DWord	Float			
kVAb_max_Year	34947	0x1352	Word	BCD	00-99		
kVAb_max_Month	34948	0x1353	Word	BCD	1-12		
kVAb_max_Date	34949	0x1354	Word	BCD	1-31		
kVAb_max_Hour	34950	0x1355	Word	BCD	0-23		
kVAb_max_Min	34951	0x1356	Word	BCD	0-59		
kVAb_max_Second	34952	0x1357	Word	BCD	0-59		
kVAb_min	34953-34954	0x1358-0x1359	DWord	Float			
kVAb_min_Year	34955	0x135A	Word	BCD	00-99		
kVAb_min_Month	34956	0x135B	Word	BCD	1-12		
kVAb_min_Date	34957	0x135C	Word	BCD	1-31		
kVAb_min_Hour	34958	0x135D	Word	BCD	0-23		
kVAb_min_Min	34959	0x135E	Word	BCD	0-59		
kVAb_min_Second	34960	0x135F	Word	BCD	0-59		
kVAc_max	34961-34962	0x1360-0x1361	DWord	Float			
kVAc_max_Year	34963	0x1362	Word	BCD	00-99		
kVAc_max_Month	34964	0x1363	Word	BCD	1-12		

kVAc_max_Date	34965	0x1364	Word	BCD	1-31		
kVAc_max_Hour	34966	0x1365	Word	BCD	0-23		
kVAc_max_Min	34967	0x1366	Word	BCD	0-59		
kVAc_max_Second	34968	0x1367	Word	BCD	0-59		
kVAc_min	34969-34970	0x1368-0x1369	DWord	Float			
kVAc_min_Year	34971	0x136A	Word	BCD	00-99		
kVAc_min_Month	34972	0x136B	Word	BCD	1-12		
kVAc_min_Date	34973	0x136C	Word	BCD	1-31		
kVAc_min_Hour	34974	0x136D	Word	BCD	0-23		
kVAc_min_Min	34975	0x136E	Word	BCD	0-59		
kVAc_min_Second	34976	0x136F	Word	BCD	0-59		
kVAtot_max	34977-34978	0x1370-0x1371	DWord	Float			
kVAtot_max_Year	34979	0x1372	Word	BCD	00-99		
kVAtot_max_Month	34980	0x1373	Word	BCD	1-12		
kVAtot_max_Date	34981	0x1374	Word	BCD	1-31		
kVAtot_max_Hour	34982	0x1375	Word	BCD	0-23		
kVAtot_max_Min	34983	0x1376	Word	BCD	0-59		

kVAtot_max_Second	34984	0x1377	Word	BCD	0-59		
kVAtot_min	34985-34986	0x1378-0x1379	DWord	Float			
kVAtot_min_Year	34987	0x137A	Word	BCD	00-99		
kVAtot_min_Month	34988	0x137B	Word	BCD	1-12		
kVAtot_min_Date	34989	0x137C	Word	BCD	1-31		
kVAtot_min_Hour	34990	0x137D	Word	BCD	0-23		
kVAtot_min_Min	34991	0x137E	Word	BCD	0-59		
kVAtot_min_Second	34992	0x137F	Word	BCD	0-59		
Frequency_max	34993-34994	0x1380-0x1381	DWord	Float			
Frequency_max_Year	34995	0x1382	Word	BCD	00-99		
Frequency_max_Month	34996	0x1383	Word	BCD	1-12		
Frequency_max_Date	34997	0x1384	Word	BCD	1-31		
Frequency_max_Hour	34998	0x1385	Word	BCD	0-23		
Frequency_max_Min	34999	0x1386	Word	BCD	0-59		
Frequency_max_Second	35000	0x1387	Word	BCD	0-59		
Frequency_min	35001-35002	0x1388-0x1389	DWord	Float			
Frequency_min_Year	35003	0x138A	Word	BCD	00-99		
Frequency_min_Month	35004	0x138B	Word	BCD	1-12		
Frequency_min_Date	35005	0x138C	Word	BCD	1-31		
Frequency_min_Hour	35006	0x138D	Word	BCD	0-23		
Frequency_min_Min	35007	0x138E	Word	BCD	0-59		
Frequency_min_Second	35008	0x138F	Word	BCD	0-59		
PF_min	35009-35010	0x1390-0x1391	DWord	Float			
PF_min_Year	35011	0x1392	Word	BCD	00-99		
PF_min_Month	35012	0x1393	Word	BCD	1-12		
PF_min_Date	35013	0x1394	Word	BCD	1-31		
PF_min_Hour	35014	0x1395	Word	BCD	0-23		
PF_min_Min	35015	0x1396	Word	BCD	0-59		
PF_min_Second	35016	0x1397	Word	BCD	0-59		
Demand_max	35017-35018	0x1398-0x1399	DWord	Float			
Demand_max_Year	35019	0x139A	Word	BCD	00-99		
Demand_max_Month	35020	0x139B	Word	BCD	1-12		
Demand_max_Date	35021	0x139C	Word	BCD	1-31		
Demand_max_Hour	35022	0x139D	Word	BCD	0-23		
Demand_max_Min	35023	0x139E	Word	BCD	0-59		
Demand_max_Second	35024	0x139F	Word	BCD	0-59		
V_Unbalance_max	35025-35026	0x13A0-0x13A1	DWord	Float			
V_Unbalance_max_Year	35027	0x13A2	Word	BCD	00-99		
V_Unbalance_max_Month	35028	0x13A3	Word	BCD	1-12		
V_Unbalance_max_Date	35029	0x13A4	Word	BCD	1-31		

V_Unbalance_max_Hour	35030	0x13A5	Word	BCD	0-23		
V_Unbalance_max_Min	35031	0x13A6	Word	BCD	0-59		
V_Unbalance_max_Second	35032	0x13A7	Word	BCD	0-59		
V_Unbalance_min	35033-35034	0x13A8-0x13A9	DWord	Float			
V_Unbalance_min_Year	35035	0x13AA	Word	BCD	00-99		
V_Unbalance_min_Month	35036	0x13AB	Word	BCD	1-12		
V_Unbalance_min_Date	35037	0x13AC	Word	BCD	1-31		
V_Unbalance_min_Hour	35038	0x13AD	Word	BCD	0-23		
V_Unbalance_min_Min	35039	0x13AE	Word	BCD	0-59		
V_Unbalance_min_Second	35040	0x13AF	Word	BCD	0-59		
I_Unbalance_max	35041-35042	0x13B0-0x13B1	DWord	Float			
I_Unbalance_max_Year	35043	0x13B2	Word	BCD	00-99		
I_Unbalance_max_Month	35044	0x13B3	Word	BCD	1-12		
I_Unbalance_max_Date	35045	0x13B4	Word	BCD	1-31		
I_Unbalance_max_Hour	35046	0x13B5	Word	BCD	0-23		
I_Unbalance_max_Min	35047	0x13B6	Word	BCD	0-59		
I_Unbalance_max_Second	35048	0x13B7	Word	BCD	0-59		
I_Unbalance_min	35049-35050	0x13B8-0x13B9	DWord	Float			
I_Unbalance_min_Year	35051	0x13BA	Word	BCD	00-99		
I_Unbalance_min_Month	35052	0x13BB	Word	BCD	1-12		
I_Unbalance_min_Date	35053	0x13BC	Word	BCD	1-31		
I_Unbalance_min_Hour	35054	0x13BD	Word	BCD	0-23		
I_Unbalance_min_Min	35055	0x13BE	Word	BCD	0-59		
I_Unbalance_min_Second	35056	0x13BF	Word	BCD	0-59		