

iMPACT User Guide



"Xilinx" and the Xilinx logo shown above are registered trademarks of Xilinx, Inc. Any rights not expressly granted herein are reserved.

CoolRunner, RocketChips, RocketIP, Spartan, StateBENCH, StateCAD, Virtex, XACT, XC2064, XC3090, XC4005, and XC5210 are registered trademarks of Xilinx, Inc.



The shadow X shown above is a trademark of Xilinx, Inc.

ACE Controller, ACE Flash, A.K.A. Speed, Alliance Series, AllianceCORE, Bencher, ChipScope, Configurable Logic Cell, CORE Generator, CoreLINX, Dual Block, EZTag, Fast CLK, Fast CONNECT, Fast FLASH, FastMap, Fast Zero Power, Foundation, Gigabit Speeds...and Beyond!, HardWire, HDL Bencher, IRL, J Drive, JBits, LCA, LogiBLOX, Logic Cell, LogiCORE, LogicProfessor, MicroBlaze, MicroVia, MultiLINX, NanoBlaze, PicoBlaze, PLUSASM, PowerGuide, PowerMaze, QPro, Real-PCI, Rocket I/O, SelectI/O, SelectRAM, SelectRAM+, Silicon Xpresso, Smartguide, Smart-IP, SmartSearch, SMARTswitch, System ACE, Testbench In A Minute, TrueMap, UIM, VectorMaze, VersaBlock, VersaRing, Virtex-II Pro, Wave Table, WebFITTER, WebPACK, WebPOWERED, XABEL, XACT-Floorplanner, XACT-Performance, XACTstep Advanced, XACTstep Foundry, XAM, XAPP, X-BLOX +, XC designated products, XChecker, XDM, XEPLD, Xilinx Foundation Series, Xilinx XDTV, Xinfo, XSI, XtremeDSP, and ZERO+ are trademarks of Xilinx, Inc.

The Programmable Logic Company is a service mark of Xilinx, Inc.

All other trademarks are the property of their respective owners.

Xilinx, Inc. does not assume any liability arising out of the application or use of any product described or shown herein; nor does it convey any license under its patents, copyrights, or maskwork rights or any rights of others. Xilinx, Inc. reserves the right to make changes, at any time, in order to improve reliability, function or design and to supply the best product possible. Xilinx, Inc. will not assume responsibility for the use of any circuitry described herein other than circuitry entirely embodied in its products. Xilinx provides any design, code, or information shown or described herein "as is." By providing the design, code, or information as one possible implementation of a feature, application, or standard, Xilinx makes no representation that such implementation is free from any claims of infringement. You are responsible for obtaining any rights you may require for your implementation. Xilinx expressly disclaims any warranty whatsoever with respect to the adequacy of any such implementation, including but not limited to any warranties or representations that the implementation is free from claims of infringement, as well as any implied warranties of merchantability or fitness for a particular purpose. Xilinx, Inc. devices and products are protected under U.S. Patents. Other U.S. and foreign patents pending. Xilinx, Inc. does not represent that devices shown or products described herein are free from patent infringement or from any other third party right. Xilinx, Inc. assumes no obligation to correct any errors contained herein or to advise any user of this text of any correction if such be made. Xilinx, Inc. will not assume any liability for the accuracy or correctness of any engineering or software support or assistance provided to a user.

Xilinx products are not intended for use in life support appliances, devices, or systems. Use of a Xilinx product in such applications without the written consent of the appropriate Xilinx officer is prohibited.

The contents of this manual are owned and copyrighted by Xilinx. © Copyright 1994-2002 Xilinx, Inc. All Rights Reserved. Except as stated herein, none of the material may be copied, reproduced, distributed, republished, downloaded, displayed, posted, or transmitted in any form or by any means including, but not limited to, electronic, mechanical, photocopying, recording or otherwise, without the prior written consent of Xilinx. Any unauthorized use of any material contained in this manual may violate copyright laws, trademark laws, the laws of privacy and publicity, and communications regulations and statutes.

About This Manual

This guide describes the iMPACT configuration tool, a command line and GUI based tool that enables you to configure your PLD designs using Boundary-Scan, Slave Serial, and SelectMAP configuration modes, as well as the MultiPRO Desktop Programmer. You can also generate programming files using iMPACT's System ACE, PROM Formatter, SVF, and STAPL file generation modes.

Manual Contents

This book contains the following chapters.

- [“Introduction”](#)
- [“Cables”](#)
- [“Designing Boundary-Scan and ISP Systems”](#)
- [“Using iMPACT to Configure Devices”](#)
- [“Using iMPACT to Generate Files”](#)
- [“Troubleshooting for Boundary-Scan Chains”](#)
- [“Glossary of Terms”](#)
- [“Boundary-Scan Basics” appendix](#)
- [“Parallel Cable III \(DLC 5\) Schematic” appendix](#)
- [“Command Line and Batch Mode Commands” appendix](#)

Additional Resources

For additional information, go to <http://support.xilinx.com>. The following table lists some of the resources you can access from this Web site. You can also directly access these resources using the provided URLs.

| Resource | Description/URL |
|-------------------|--|
| Tutorials | Tutorials covering Xilinx design flows, from design entry to verification and debugging http://support.xilinx.com/support/techsup/tutorials/index.htm |
| Answers Database | Current listing of solution records for the Xilinx software tools Search this database using the search function at http://support.xilinx.com/support/searchtd.htm |
| Application Notes | Descriptions of device-specific design techniques and approaches http://support.xilinx.com/apps/appsweb.htm |
| Data Book | Pages from <i>The Programmable Logic Data Book</i> , which contains device-specific information on Xilinx device characteristics, including readback, Boundary-Scan, configuration, length count, and debugging http://support.xilinx.com/partinfo/databook.htm |
| Xcell Journals | Quarterly journals for Xilinx programmable logic users http://support.xilinx.com/xcell/xcell.htm |
| Technical Tips | Latest news, design tips, and patch information for the Xilinx design environment http://support.xilinx.com/support/techsup/journals/index.htm |

Conventions

This manual uses the following conventions. An example illustrates most conventions.

Typographical

The following conventions are used for all documents.

- **Courier font** indicates messages, prompts, and program files that the system displays.

```
speed grade: - 100
```

- **Courier bold** indicates literal commands that you enter in a syntactical statement. However, braces “{ }” in Courier bold are not literal and square brackets “[]” in Courier bold are literal only in the case of bus specifications, such as bus [7:0].

```
rpt_del_net=
```

Courier bold also indicates commands that you select from a menu.

File → **Open**

- *Italic font* denotes the following items.
 - ◆ Variables in a syntax statement for which you must supply values

```
edif2ngd design_name
```

- ◆ References to other manuals

See the *Development System Reference Guide* for more information.

- ◆ **Emphasis in text**

If a wire is drawn so that it overlaps the pin of a symbol, the two nets are *not* connected.

- Square brackets “[]” indicate an optional entry or parameter. However, in bus specifications, such as bus [7:0], they are required.

```
edif2ngd [option_name] design_name
```

- Braces “{ }” enclose a list of items from which you must choose one or more.

```
lowpwr = {on|off}
```

- A vertical bar “|” separates items in a list of choices.

```
lowpwr = {on|off}
```

- A vertical ellipsis indicates repetitive material that has been omitted.

```
IOB #1: Name = QOUT'
```

```
IOB #2: Name = CLKIN'
```

```
.  
. .  
. . .
```

- A horizontal ellipsis “...” indicates that an item can be repeated one or more times.

```
allow block block_name loc1 loc2 ... locn;
```

Online Document

The following conventions are used for online documents.

- **Blue text** indicates cross-references within a book. **Red text** indicates cross-references to other books. Click the colored text to jump to the specified cross-reference.
- **Blue, underlined text** indicates a Web site. Click the link to open the specified Web site. You must have a Web browser and internet connection to use this feature.

Contents

About This Manual

| | |
|----------------------------|-----|
| Manual Contents | iii |
| Additional Resources | iv |

Conventions

| | |
|-----------------------|----|
| Typographical | v |
| Online Document | vi |

Chapter 1 Introduction

| | |
|--|------|
| Configuration Device Operations Available to Users | 1-1 |
| Non-Volatile Device Data Security | 1-2 |
| Required Files | 1-3 |
| JEDEC Files | 1-3 |
| BSDL Summary | 1-3 |
| BIT Files | 1-3 |
| PROM Files | 1-4 |
| RBT Files | 1-4 |
| Chain Description Files | 1-4 |
| iMPACT Features | 1-4 |
| User Feedback | 1-5 |
| PROM Formatter | 1-5 |
| Serial PROMs | 1-5 |
| Parallel PROMs. | 1-6 |
| System ACE | 1-6 |
| MultiPRO Desktop Programmer (MultiPRO) | 1-6 |
| iMPACT Platform Support | 1-6 |
| Starting iMPACT | 1-7 |
| From Project Navigator | 1-7 |
| From the Command Line | 1-7 |
| Exiting iMPACT | 1-7 |
| Using the Interface | 1-7 |
| Main Window | 1-7 |
| Title Bar | 1-7 |
| Menu Bar | 1-8 |
| Toolbar | 1-8 |
| Status Window | 1-10 |

| | |
|---|------|
| Commands and Dialog Boxes | 1-10 |
| Common Fields | 1-11 |
| Selection Dialog Boxes | 1-11 |
| Selecting Commands and Dialog Box Options | 1-11 |
| Using the Mouse | 1-11 |
| Using the Keyboard | 1-12 |
| Using Help | 1-12 |
| Help Menu | 1-12 |
| Toolbar Help Button | 1-13 |
| F1 Key | 1-13 |
| Help Button in Dialog Boxes | 1-13 |
| Architecture Support | 1-13 |

Chapter 2 Cables

| | |
|---|------|
| Download Cables | 2-1 |
| Cable Support | 2-2 |
| Cable Baud Rates | 2-2 |
| Software and Cable Interface | 2-3 |
| Cable Auto Connect (Automatic) | 2-3 |
| Cable Setup (Manual) | 2-3 |
| Resetting the Cable | 2-5 |
| Disconnecting the Cable | 2-5 |
| Target Board Requirements | 2-5 |
| High Performance Ribbon Cable | 2-5 |
| Flying Lead Connectors | 2-6 |
| Flying Leads | 2-6 |
| Mode Pin Connections for FPGAs Only | 2-6 |
| Parallel Cables | 2-7 |
| Parallel Cable IV | 2-7 |
| Connecting to Host Computer | 2-8 |
| Cable Power | 2-8 |
| High Performance Ribbon Cable | 2-9 |
| Target Board Header | 2-10 |
| Parallel Cable III | 2-12 |
| Connecting for System Operation | 2-13 |
| Serial Configuration Connection | 2-15 |
| MultiPRO Desktop Tool | 2-17 |
| Connecting to Host Computer | 2-19 |
| Cable Power | 2-19 |
| High Performance Ribbon Cables | 2-19 |
| Desktop Programming | 2-21 |
| MultiLINX Cable | 2-24 |
| MultiLINX Power Requirements | 2-25 |
| MultiLINX Cable and Flying Leads | 2-25 |
| MultiLINX Connection and Power Sequence | 2-30 |
| Connecting Cable to Target System | 2-30 |

Chapter 3 Designing Boundary-Scan and ISP Systems

| | |
|---|-----|
| Connecting Devices in a Boundary-Scan Chain | 3-1 |
|---|-----|

| | |
|--|------|
| FPGA Device Considerations | 3-3 |
| Bitstream Considerations | 3-3 |
| Virtex Considerations | 3-3 |
| Device Behavior Notes | 3-3 |
| Selecting a Configuration Mode | 3-4 |
| FPGA Supported Modes | 3-5 |
| JTAG or Boundary-Scan Mode | 3-5 |
| SelectMAP/Slave-Parallel Modes | 3-5 |
| Master SelectMAP Mode | 3-5 |
| Master-Serial Mode | 3-5 |
| Slave-Serial Mode | 3-6 |
| CPLD/PROM Supported Modes | 3-6 |
| Standalone Programmer Mode | 3-6 |
| JTAG or Boundary-Scan Mode | 3-6 |
| Programming and Configuring Options | 3-6 |
| CPLD Programming Options | 3-6 |
| ATE/Embedded Solutions | 3-7 |
| MultiPRO Desktop Programmer | 3-7 |
| Third Party Programmers | 3-8 |
| FPGA Configuration Flows | 3-8 |
| Embedded Solutions | 3-8 |
| PROM | 3-9 |
| PROMGen/PROM Formatter | 3-9 |
| Third Party Programmers | 3-10 |
| Xilinx Common Configuring and Programming Setups | 3-10 |
| CPLD JTAG Chain Setup | 3-10 |
| Hardware Considerations | 3-11 |
| General JTAG Checklist | 3-12 |
| XC9500/XL/XV Specific Checklist | 3-12 |
| XPLA3 Specific Checklist | 3-13 |
| Software Implementation Considerations | 3-13 |
| Software Download Considerations | 3-13 |
| Prototyping Environment | 3-14 |
| Production Environment | 3-14 |
| Virtex Series or Spartan-II Master Serial and Boundary-Scan (JTAG) Combination Setup | 3-14 |
| Hardware Considerations | 3-16 |
| Virtex Spartan-II Master Serial and Boundary-Scan (JTAG) Mode Connections | 3-16 |
| Software Implementation Considerations | 3-17 |
| Software Download Considerations | 3-18 |
| Prototyping | 3-18 |
| Production | 3-18 |
| Configuration Checklist | 3-18 |

Chapter 4 Using iMPACT to Configure Devices

| | |
|--|-----|
| Configuration Mode General Information | 4-1 |
| Connecting to a Cable | 4-3 |
| Boundary-Scan Configuration Mode | 4-5 |

| | |
|--|------|
| Automatically Creating the Chain | 4-5 |
| Manually Creating the Chain | 4-6 |
| Assigning Configuration Files | 4-7 |
| Saving the Chain Description | 4-9 |
| Edit Preferences | 4-10 |
| Available Boundary-Scan Operations | 4-11 |
| Performing Boundary-Scan Operations | 4-12 |
| Slave Serial Configuration Mode | 4-15 |
| Adding a Device | 4-15 |
| Programming the Device | 4-18 |
| Troubleshooting Slave Serial Configuration | 4-19 |
| SelectMAP Configuration Mode | 4-21 |
| Adding a Device | 4-21 |
| Programming and Verifying a Device | 4-24 |
| Troubleshooting SelectMAP Programming and Verify | 4-25 |
| Desktop Configuration Mode | 4-27 |
| Automatically Identifying the Device | 4-27 |
| Manually Identifying the Device | 4-28 |
| Assigning a Configuration File | 4-28 |
| Setting Options | 4-28 |
| Performing Device Operations | 4-30 |

Chapter 5 Using iMPACT to Generate Files

| | |
|---|------|
| General File Mode Instructions | 5-2 |
| Creating System ACE Programming Files | 5-3 |
| System ACE CF Settings | 5-4 |
| Size | 5-4 |
| Reserve Space | 5-4 |
| System ACE CF Collection Name | 5-4 |
| Location | 5-4 |
| Configuration Address | 5-4 |
| Design Name | 5-5 |
| System ACE MPM Settings | 5-5 |
| Size (16,32,64, Generic) | 5-5 |
| System ACE MPM Name | 5-5 |
| Location | 5-5 |
| Target in: Slave Serial Mode or SelectMAP Mode | 5-5 |
| Slave Serial Mode > Number Of Chains | 5-5 |
| SelectMAP Mode > Specify CS Pin to be used in this design | 5-6 |
| Configuration Address | 5-6 |
| File Generation > Compress File | 5-6 |
| Adding Files to System ACE Devices | 5-6 |
| System ACE CF | 5-7 |
| System ACE CF Screen | 5-7 |
| Viewing Different Configuration Addresses | 5-9 |
| Adding More Devices After the Wizard Has Finished | 5-9 |
| Assigning a Different File to a Device | 5-9 |
| Managing Multiple Collections | 5-9 |
| Generating System ACE CF Files | 5-10 |

| | |
|---|------|
| System ACE MPM | 5-11 |
| System ACE MPM Screen | 5-11 |
| Viewing Different Configuration Addresses | 5-14 |
| Adding More Devices After the Wizard Has Finished | 5-14 |
| Assigning a Different File to a Device | 5-14 |
| Generating System ACE MPM Files | 5-14 |
| Creating PROM Formatter Programming Files | 5-16 |
| General PROM File Information | 5-16 |
| PROMs | 5-16 |
| PROM Formatter Files | 5-16 |
| BIT Swapping in PROM Files | 5-17 |
| Implementing Your Applications | 5-18 |
| Single Application PROM Files | 5-19 |
| Multiple Application PROM Files | 5-19 |
| Configuration Setups | 5-20 |
| XILINX PROM Part Names | 5-20 |
| PROM Formatter Operations | 5-20 |
| Serial PROM Settings | 5-20 |
| Parallel PROM Settings | 5-21 |
| Adding Files to PROM Devices | 5-22 |
| Generating PROM Files | 5-23 |
| Serial PROM File Creation | 5-23 |
| Parallel PROM File Creation | 5-25 |
| Creating an SVF or STAPL File | 5-27 |
| Creating the chain | 5-27 |
| Selecting the Programming File | 5-27 |
| Writing to an SVF or STAPL File | 5-28 |

Chapter 6 Troubleshooting for Boundary-Scan Chains

| | |
|---------------------------------|-----|
| Communication | 6-1 |
| Improper Connections | 6-2 |
| Improper or Unstable Vcc | 6-3 |
| Boundary-Scan Chain Debug | 6-3 |
| System Noise | 6-5 |

Glossary of Terms

Appendix A Boundary-Scan Basics

| | |
|--|-----|
| Boundary-Scan/IEEE Standard 1149.1 | A-1 |
| What can it be used for? | A-1 |
| How does it work? | A-2 |
| The TAP Controller | A-2 |
| The Instruction Register | A-2 |
| The Data Registers | A-2 |
| Impact Test Access Port | A-2 |
| JTAG TAP Controller | A-3 |
| JTAG TAP Controller States | A-3 |
| Mandatory Boundary-Scan Instructions | A-5 |
| Optional Boundary-Scan Instructions | A-5 |

Configuring the Parallel Download CableA-5

Appendix B Parallel Cable III (DLC 5) Schematic

Appendix C Command Line and Batch Mode Commands

Difference Between Command Line and Batch Mode Operation .C-1

Command Line UsageC-2

Command Line OptionsC-2

Batch Mode CommandsC-3

 Batch Mode DefinitionsC-4

 General CommandsC-5

Configuration Mode CommandsC-6

 General Configuration Mode CommandsC-6

 Boundary-Scan Mode Specific CommandsC-8

File Generation Mode CommandsC-9

 PROM Formatter Specific CommandsC-10

 System ACE Specific CommandsC-10

Example Batch Mode Command SequencesC-10

 General Batch Command Sequence FormatC-11

 Command Sequence Example 1: Creating a Chain Using addDe-
 viceC-11

 Command Sequence Example 2: Chain Consisting of: XC18V04
 (programmed), Third Party Device (bypassed) XC18v04 (pro-
 grammed), XC18V04 (bypassed with .bsd file)C-13

 Command Sequence Example 3: Using JTAG to Automatically
 Identify a ChainC-13

 Command Sequence Example 4: Loading a .cdf File and Program-
 ming a DeviceC-14

JTAGPROG to iMPACT Script MigrationC-14

 Getting StartedC-14

 Determining the Part NameC-14

 Programming and Verifying a DeviceC-15

 JTAGPROGC-15

 iMPACTC-16

 iMPACT (XC18V00 Family)C-16

 iMPACT (when assigning a BSDL file)C-16

 Example: Programming a XC18v00 PROMC-17

 JTAGPROGC-17

 iMPACTC-17

 iMPACT (SVF mode)C-17

 Example: XC2v1000 Device (bypassed with a .bit file) in a Chain with
 an XC18v04 Device (programmed)C-18

 iMPACTC-18

 iMPACT (SVF mode)C-18

 Example: XC2v1000 (programmed) in a Chain with a XC18v04 (by-
 passed with a BSDL file)C-19

 JTAGPROGC-19

 iMPACTC-19

 iMPACT (SVF mode)C-19

 Example: Chain Consisting of XC18v04 (programmed), Third Party De-

| | |
|--|------|
| vice (bypassed), XC18v04 (programmed), XC18v04 (bypassed with a .bsd file) | C-20 |
| JTAGPROG | C-20 |
| iMPACT | C-20 |
| iMPACT (SVF mode) | C-21 |

Introduction

This chapter introduces you to the basic concepts of the iMPACT software and related Xilinx in-system programmable products. You can use iMPACT to download, read back and verify design configuration data as well as to create PROM, SVF, STAPL, System ACE CF and System ACE MPM programming files. This chapter contains the following sections:

- “Configuration Device Operations Available to Users”
- “Non-Volatile Device Data Security”
- “Required Files”
- “iMPACT Features”
- “iMPACT Platform Support”
- “Starting iMPACT”
- “Using the Interface”
- “Using Help”
- “Architecture Support”

Configuration Device Operations Available to Users

Program. Downloads the contents of the JEDEC, BIT or PROM file to the device.

Verify. Reads back the contents of the device configuration and compares them with the JEDEC, BIT or PROM file.

Erase. Clears device configuration information.

Functional Test. Applies user-specified functional vectors from the JEDEC file to the device using the JTAG INTEST instruction,

comparing results obtained against expected values. Reports any differences to the user.

Blank Check. Checks whether a device is in a programmed or erased state.

Readback. Reads back the contents of the device configuration and creates a new JEDEC or PROM file with the results.

Program XPLA UES. This is a Coolrunner only option. Programs the user electronic signature of the selected devices.

Get Device ID. Reads the contents of the JTAG IDCODE register. Displays contents for the user.

Get Device Checksum. Reads back the contents of device configuration registers and calculates a checksum for comparison against the expected value specified in the JEDEC or PROM file.

Get Device Signature/Usercode. For FPGAs and CPLDs this value is selected by the user during program file generation. The specified value is translated to binary values in the JEDEC file. During device programming these values are loaded into the JTAG USERCODE register. This function reads the contents of the USERCODE register and displays the result.

Get XPLA Device UES. This is a CoolRunner only option. Gets the user electronic signature from the selected devices in the JTAG chain.

IDCODE Looping. Performs IDCODE operations a specified number of times.

Non-Volatile Device Data Security

Any Xilinx XC9500 family device selected for programming can be secured with the Write Protect or Read Protect or both. CoolRunner, CoolRunner-II, and PROM devices can be secured with the Read Protect only.

When enabled, Read Protect disables reading the programmed contents of a device (the IDCODE, USERCODE and all Boundary-Scan registers remain readable).

Write Protect enables only the reading of the programmed data. The device contents cannot be altered or re-programmed.

When both Read Protect and Write Protect are enabled, the device programmed data can be neither read nor re-programmed.

Required Files

For Boundary-Scan programming, you need to provide JEDEC files for each CPLD family device, BIT files for each Xilinx FPGA device, .mcs or .exo files for each PROM device, and BSDL files for the remaining devices.

For Slave Serial programming, you must provide a single BITfile if there is only one FPGA, or an .mcs/.exo file for Serial daisy chains with multiple FPGAs.

For SelectMAP programming, you must provide a BITfile for each target device.

JEDEC Files

JEDEC files are CPLD programming files generated by the Xilinx fitter. They are ASCII text files containing programming information that describes the desired functional implementation of the user's design. One JEDEC file is required for each CPLD device in the JTAG programming chain.

BSDL Summary

The Boundary-Scan Description Language (BSDL) files use a subset of VHDL to describe the Boundary-Scan features of a device. iMPACT automatically extracts the length of the instruction register from the BSDL file to place non-Xilinx devices in bypass mode. Xilinx BSDL files are located automatically by iMPACT.

BIT Files

BIT files are Xilinx FPGA configuration files generated by the Xilinx FPGA design software. They are proprietary format binary files containing configuration information. One BIT file is required for each Xilinx FPGA in a Boundary-Scan chain, for a single Slave Serial connected device, or for each SelectMAP connected device.

PROM Files

PROM files are PROM programming files generated either by iMPACT using the PROM Formatter tab in the File Generation mode, or by the command line utility, PROMGen. The PROM files are ASCII text files used to specify configuration data. PROM files are also used to download a serial daisy chain of multiple FPGAs.

A Xilinx PROM file may consist of one or more data streams. In this context, a data stream represents all the configuration data required to implement a given application. Each data stream contains one or more BIT files and once saved, has a separate preamble and length count.

The PROM file can be formatted in one of three industry standard formats: Intel MCS-86® (.mcs), Tektronix TEKHEX (.tek), and Motorola EXOR-macs (.exo).

The PROM Formatter performs the same function as the PROMGen program, which can be executed from the UNIX™ or PC command line. Refer to the *Development System Reference Guide* for details about PROMGen.

RBT Files

A Raw BIT File is an ASCII version of the BIT file. The only difference is that the header information in a BIT File is removed from the Raw BIT File. This is also created by BitGen and is used to program a single FPGA.

Chain Description Files

A Chain Description file is used to save and restore information about the composition of device configuration chains. It stores information about the order of devices in the chain and the configuration data file associated with each device.

iMPACT Features

You can use iMPACT to perform the following functions.

- Configure one or more devices
- Verify configuration data for single devices

- Create PROM, SVF, STAPL, System ACE CF, and System ACE MPM programming files.

For downloading, use any of the three configuration data file types (BIT, JEDEC, or PROM) and any download cable.

For single device verification of Xilinx FPGAs, use a BIT file. In addition, you will need to generate a MSK file. Be certain to include the readback symbol in your design and optionally, the STARTUP symbol. Verification ensures that a device's configuration memory contents match the source configuration file contents. It does not ensure the device has started up and is functioning. Only actual system verification can verify start up and overall function.

User Feedback

When using the graphical user interface, immediate feedback is provided by a scrolling log file and alert boxes. Detailed information regarding operation history and status is displayed in the status window and collected in the iMPACT log file.

PROM Formatter

The PROM Formatter tab enables you to format BIT files into a PROM file compatible with Xilinx and third-party PROM programmers. It is also used to concatenate multiple bitstreams into a single PROM file for daisy chain applications. This feature also enables you to take advantage of the Xilinx FPGA reconfiguration capability, as you can store several applications in the same PROM file.

PROM files are also compatible with iMPACT's configuration mode. You can use iMPACT to download a PROM file to an XC18V00 series PROM, a single FPGA, or a slave serial daisy chain of FPGA devices.

Serial PROMs

Serial PROMs are PROMs that are read one BIT at a time. In Serial PROM mode, you can create files that:

- Configure a single device with one or more PROM devices.
- Configure daisy-chained devices with one or more PROM devices.

Parallel PROMs.

A Parallel PROM is a PROM that is read one byte at a time. In Parallel PROM mode, you can create files that:

- Configure a single device with one or more applications.
- Configure daisy-chained devices with one or more applications.

System ACE

System ACE is a Xilinx-developed configuration environment that enables space-efficient, pre-engineered, high-density configuration solutions for systems with multiple FPGAs. There are two versions of System ACE; System ACE CF and System ACE MPM. See the [“Using iMPACT to Generate Files” chapter](#) for more information.

MultiPRO Desktop Programmer (MultiPRO)

The MultiPRO download cable is a multi-function download cable capable of facilitating socket based, single device configuration using Boundary-Scan as well as standard device configuration using Slave Serial, or SelectMAP interfaces.

- The MultiPRO connects to your PC using an IEEE-1284 standard parallel port.
- The MultiPRO supports the CoolRunner-II CPLD family, and the XC 18V00 Flash PROM family.

iMPACT Platform Support

iMPACT supports the following platforms.

Table 1-1 Platform Support

| Cable | Platforms | Ports |
|------------|---------------------|------------|
| MultiLINUX | Sol/Win2000/ME/XP | RS-232,USB |
| Parallel | WinNT/Win2000/ME/XP | Parallel |
| MultiPRO | WinNT/Win2000/ME/XP | Parallel |

Starting iMPACT

This section explains how to start and exit iMPACT.

From Project Navigator

To start iMPACT from Project Navigator, follow these steps:

- In the Processes for Current Source window, double click the “Configure Device (iMPACT)” selection under the “Generate Programming File” process.

From the Command Line

To start iMPACT from the UNIX[®] or DOS[™] command prompt, enter the following command:

```
impact
```

If you want to start iMPACT with a `.bit`, `.cdf`, or `.jed` extension, or use iMPACT in batch mode, please see Appendix C for further instructions.

Exiting iMPACT

To exit iMPACT, select **File** → **Exit**. If you have an open window, you are prompted to save the data before quitting the application.

Using the Interface

This section describes the iMPACT interface.

Main Window

The main window is the background against which all other windows are displayed.

Title Bar







The title bar displays the program name followed by the name of the currently loaded design.









Menu Bar



The menu bar, located at the top of the window, includes the File, Edit, Mode, Operations, Output, View, and Help menus. You can also select menu commands by typing the letter underlined in the menu name while holding down the Alt key.

Toolbar

The toolbar, located below the menu bar, consists of buttons that you can use to execute commands. Place the mouse pointer over each button to display the command associated with the button. The command name appears as a “tool tip” and the status bar provides more descriptive information.

| Button | Name | Function |
|---|-------|--|
|  | New | Removes all configuration descriptions from all tabs to let you start a new configuration description. |
|  | Open | Open an existing CDF file. |
|  | Save | Saves the active chain file. Clicking this button is the same as selecting Save in the file menu. |
|  | Cut | Removes a selection from the iMPACT main window and temporarily stores it on the clipboard. |
|  | Copy | Copies a device and temporarily stores a copy of it on the clipboard. |
|  | Paste | Inserts data stored on the clipboard into the iMPACT main window. |

| Button | Name | Function |
|---|-------------------------------|---|
|  | Toggle Mode | Switches iMPACT tabs between Configuration and File Generation modes. |
|  | Initialize Chain | Automatically detects the number and types of devices in a Boundary-Scan chain. |
|  | Debug Chain | Initiates rudimentary Boundary-Scan TAP debug operations. |
|  | Select All | Selects all the devices in the chain. |
|  | Unselect All | Unselects all the devices in the chain. |
|  | Add Xilinx Device | Adds a new Xilinx device to the chain. |
|  | Assign New Configuration File | Changes the current device configuration file selection. |
|  | Program | Configures the selected device or devices. |
|  | Verify | Verifies the correct configuration has been programmed to the device. |

| Button | Name | Function |
|---|-------|---|
|  | Erase | Erases the contents of a programmed device. |
|  | About | Displays the program information and copyright. |
|  | Help | Invokes context-sensitive help. When you click this button, the cursor changes into a large question mark with an arrow. You can then select an object, such as a menu command or a toolbar button, and receive help for that object. |

Status Window

The status window, located at the very bottom of the iMPACT window, is broken into five individual display panes on the right side, and general display section on the left. The status window provides command and application state information. When you select a menu command, a brief description of the command's function appears on the left side status window. The five right side status panes display (from left to right) the application operation mode, the active sub mode, the cable being used, the cable port, and the cable port speed.

Commands and Dialog Boxes

You communicate with iMPACT by selecting commands from the menus and the toolbar.

Common Fields

The fields shown in the following table are common to most dialog boxes.

Table 1-2 Common Dialog Box Fields

| Dialog Box Field | Function |
|------------------|--|
| OK | Closes the dialog box and implements the intended action according to the settings in the dialog box |
| Help | Displays information on that particular dialog box |
| Cancel | Closes the dialog box without affecting any action |
| Cancel All | Cancels the current configuration setup |

The standard file open and file save dialog boxes enable you to load a project file or save a project file. This type of dialog box includes a file browser.

Selection Dialog Boxes

Use Selection dialog boxes to specify specific values and selections.

Selecting Commands and Dialog Box Options

To choose a menu item, a toolbar button, or a dialog box option, you can use the mouse or the keyboard.

Using the Mouse

1. Move the mouse cursor over the object you want to select, and click the left mouse button to select the object.
2. To exit a dialog box without making a selection, click **Cancel** or double-click the close box in the upper left corner of the dialog box.
3. To obtain help, click **Help** in the dialog box.

Using the Keyboard

You can use the keyboard to select objects on your screen, such as a dialog box button or a menu option.

1. To select a dialog box option, use the **Tab** key to position the cursor on that object and highlight it. Press the **Enter** key to process the selection.

To exit a dialog box without making a selection, press the **Esc** key.
2. To choose a menu and display its commands, press the **Alt** key and the appropriate underlined letter key corresponding to the menu you want. For example, press **Alt F** to select the File menu.
3. Use the arrow keys to scroll down the list of commands in a menu or the options in a list box. Press **Enter** when the selection you want to use is highlighted or, in the case of a menu item, press the underlined letter corresponding to the menu command. For example, press the **N** key to select the New command of the File menu.

Using Help

iMPACT includes both context-sensitive help and a Help menu. You can obtain help on commands and procedures through the Help menus or by selecting the Help toolbar button. In addition, the dialog boxes associated with many commands have a Help button that you can click to obtain context-sensitive help.

Help Menu

Use the following Help menu commands to get help.

- The Help Topics command opens the online help and lists the various topics available for iMPACT. From the Help Topics page, you can jump to command information or step-by-step instructions for using iMPACT. When you want to return to the help topic list, click the Help Topics button.
- The Online Documentation command provides access to the online documentation.

- The About iMPACT command displays a popup window that shows the version number of the iMPACT software and a copyright notice.
- The Supported Devices command displays a list of devices supported in iMPACT.

Toolbar Help Button

Click once with the left mouse button on the menu item or toolbar button for which you want help. iMPACT displays help for the selected command or option.

Note: You can also press `Shift F1` to obtain context-sensitive help.

F1 Key

Pressing the F1 key on a dialog box displays help on that dialog box. Pressing the F1 key is the same as selecting Help → Help Topics, if no dialog boxes are displayed.

Help Button in Dialog Boxes

Many of the dialog boxes in iMPACT have a Help button that you can click to get help on the dialog box options. You can also press `Alt H` or `F1` on your keyboard with the cursor positioned over the dialog box to access the online help.

Architecture Support

The software supports the following architecture families in this release.

- Virtex-II Pro™
- Virtex™/E/II
- Spartan™ II/IIE
- CoolRunner™ XPLA3 /II
- XC9500™ (Version 2 or greater)
- XC9500XL/XV
- XC18V00 PROMs

- XC17V00 PROM's -File Generation Only
- System ACE CF
- System ACE MPM

Cables

This chapter gives specific information about using cables to download from the iMPACT Configuration Tool to devices in-system.

This chapter contains the following sections.

- “Download Cables”
- “Cable Support”
- “Software and Cable Interface”
- “Target Board Requirements”
- “Parallel Cables”
- “MultiPRO Desktop Tool”
- “MultiLINX Cable”
- “MultiLINX Connection and Power Sequence”

Download Cables

There are four cables available for use with the iMPACT Configuration Tool. The first is the Parallel Download Cable III which is connected to a PC's parallel port. The second is the Parallel Cable IV which is also parallel port connected and backward compatible to the Parallel Cable III. The third is the MultiLINX cable which is connected to a USB port or serial port. The fourth is the MultiPRO desktop tool which can be used as a download cable or desktop programmer. The USB port is used on Win2000/ME/XP. There are a few options to be considered in selecting a cable:

- The MultiLINX Cable connects to the serial port of both PCs and workstations or the USB port on a PC.

- The Parallel Cable IV is over 10 times faster than Parallel Cable III and over 5 times faster than the MultiLINX cable.
- All four cables are ChipScope ILA compatible.

Cable Support

iMPACT supports the following cables.

Table 2-1 Cable Support

| Name | Platforms | Voltages | Modes | Notes |
|----------------------------------|-----------------|----------------------------|---|---|
| MultiLINX Cable (Model: DLC6) | PC, Workstation | 2.5, 3.3, 5 Volt | JTAG, Slave Serial, SelectMAP | The USB port can be used on Win2000/ME/XP. It cannot be used on Win95 or WinNT. |
| Parallel Cable IV (Model: DLC7) | PC | 1.5, 1.8, 2.5, 3.3, 5 Volt | JTAG, Slave Serial | |
| Parallel Cable III (Model: DLC5) | PC | 2.5, 3.3, 5 Volt | JTAG, Slave Serial | Replaced by PC IV in March 2002. |
| MultiPRO | PC | 1.5 - 5 Volt | Desktop Programmer, JTAG, Slave Serial, SelectMAP | |

Cable Baud Rates

The supported Baud Rates for the cables are shown in the following table.

Table 2-2 Cable Baud Rates

| Cable | PC | WorkStation |
|--------------------------|-------------------------------|--|
| MultiLINX Cable (USB) | 1 M-12 M | USB is currently not supported on WorkStation. |
| MultiLINX Cable (RS-232) | 9600, 19200, 38400, and 57600 | 9600, 19200, and 38400 |
| Parallel Cable III | Not Selectable | Not Applicable |

Table 2-2 Cable Baud Rates

| Cable | PC | WorkStation |
|-------------------|----------------|--------------------|
| Parallel Cable IV | Not Selectable | Not Applicable |
| MultiPRO | Not Selectable | Not Applicable |

Software and Cable Interface

iMPACT allows for both automatic and manual cable connections.

Cable Auto Connect (Automatic)

Select **Output** → **Cable Auto Connect** if you want the software to scan for the presence of a cable and automatically establish communication. Cable information is presented in the status bar.

If you select any operation that requires a cable, such as **Program** or **Initialize Chain**, without first selecting a cable connection, iMPACT attempts to auto connect.

Cable Setup (Manual)

After connecting the cable to download and verify, power your target board to enable the software to communicate with the cable and start iMPACT. You then set the cable options manually with the following steps:

1. Select **Output** → **Cable Setup** to display the Cable Communication Setup dialog box, shown in the following figure.

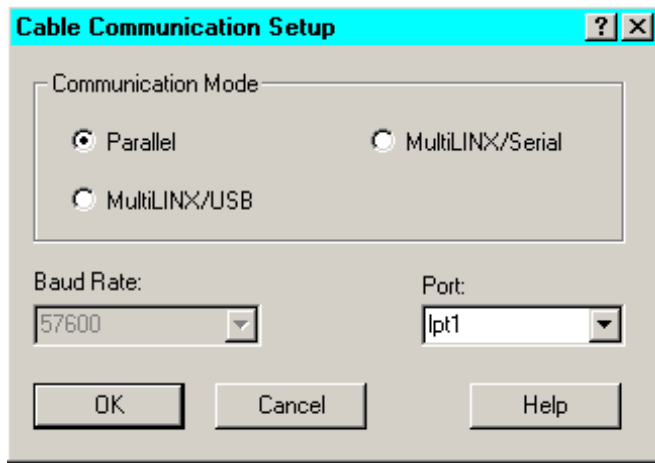

Figure 2-1 Cable Communication Setup Dialog Box

2. In the Communication Mode field, select the cable type that you installed for downloading. The Parallel Cable is supported for the PC only.
3. In the Port list box, select the port to use for downloading and readback. If the port name you want is not listed, select the blank name from the list box and type in the new port name. This list box saves up to two user-specified port names.

The Port list box contains a list of valid ports for the platform, as shown in the following table. If you selected the MultiLINX Cable, the USB port is displayed. If you selected a serial cable, the serial ports are displayed. If you selected a parallel cable, the parallel ports are displayed.

Table 2-3 USB, Serial, and Parallel Ports

| Platform | USB Ports | Serial Ports | Parallel Ports |
|----------|-----------|------------------------|------------------------|
| Sol | none | /dev/ttya, /dev/ttyb | not supported |
| PC | USB | com1, com2, com3, com4 | lpt1, lpt2, lpt3, lpt4 |

4. In the Baud Rate list box, select a communications baud rate between the cable and the host system. You cannot specify the baud rate for a parallel cable.

Communication speed between the host system and the Cable depends on host system capability. Refer to the “Valid Baud Rates” table for a list of valid baud rates.

5. Click **OK** to accept the selections.
iMPACT attempts to connect to the cable.

Resetting the Cable

To reset internal logic of the cable after a power glitch, select **Output** → **Cable Reset** to reset the internal logic of the cable. The cable is reinitialized and the proper baud rate is set.

Reset your cable if you experience a power failure to the target device board.

Disconnecting the Cable

To disconnect the cable connection, select **Output** → **Cable Disconnect**.

Note You need to disconnect the cable if you want to use the same cable in a different configuration mode. For instance, if you start using the parallel cable in Boundary-Scan mode, then wish to use it for Slave Serial configuration, you first have to disconnect it in Boundary-Scan and reconnect it in Slave Serial mode.

Target Board Requirements

The following are general target board requirements for all target boards regardless of the type of cable being used. Specific cables and configuration modes may have additional target board requirements.

High Performance Ribbon Cable

The Parallel Cable IV uses a high performance ribbon cable which incorporates multiple signal-ground pairs. The cable has a single 14-pin connector which requires a corresponding 14-pin board header with 0.5mm square posts on 2mm centers.

When you lay out the printed circuit board for use with iMPACT in-system programming and testing, a few adjustments make the process of connecting and downloading easier. Place pins or header on the board so that flying leads or the high performance ribbon cable

can reach them. The length of our flying leads is either six inches (Parallel Cable) or twelve inches (MultiLINX Cable). The ribbon cable is recommended for all new designs in order to achieve the highest configuration data throughput. When using the ribbon cable, you must select **Ribbon Cable** in the Cable Leads section of the Preferences dialog box.

Note The Ribbon Cable is available for the Parallel IV and MultiPRO only. The high performance ribbon cable is 6" long.

Flying Lead Connectors

Some Xilinx cables use flying lead connectors that have individual female connectors on one end that fit onto standard 0.025" square male pins on your target board. Each lead is labeled to identify the proper pin connection.

Flying Leads

- Provide pins on your printed circuit board for your desired configuration mode. For example, Boundary-Scan configuration would require Vcc, GND, TCK, TDO, TDI and TMS header pins.
- These pins must be standard 0.025" square male pins that have dedicated traces to the target device control pins. You connect to these pins with the flying lead connector.
- While pins may be a couple of inches apart, do not have any two JTAG connector pins more than six inches apart.

Note When using flying leads, you must select **Flying Leads** in the Cable Leads section of the Preferences dialog box to insure safe operation of the cable. You also need to keep header pins on your board a minimum of 0.10" apart.

Mode Pin Connections for FPGAs Only

When using download cables to configure a device or chain of devices, you must set the appropriate device configuration mode. You must set M0, M1, and M2 to the value specified in the device's databook for the desired mode. Refer to the *Development System Guide* or *The Programmable Logic Data Book* for information on setting the mode pins.

Parallel Cables

If you are using a Parallel Download Cable proceed to the Parallel Cable section.

If you have a MultiLINX Cable proceed to the MultiLINX Cable section.

Parallel Cable IV

Parallel Cable IV

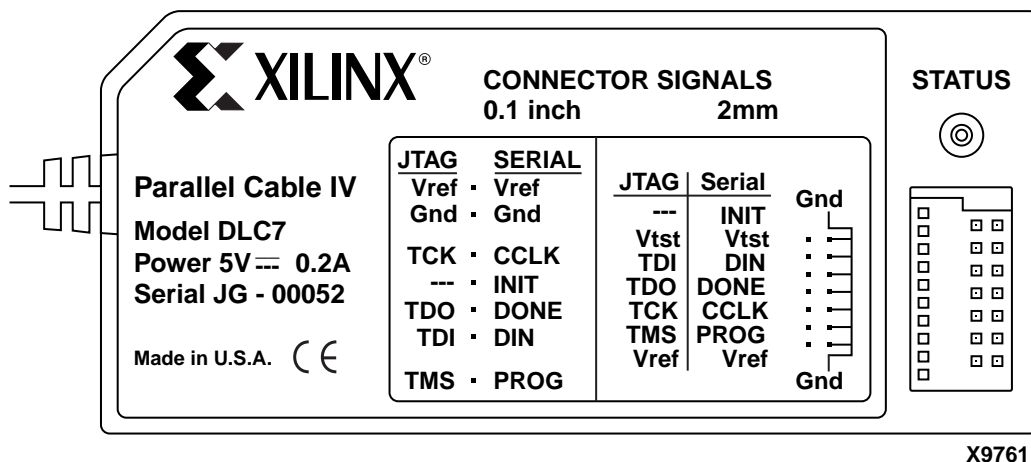

Figure 2-2 Top View of the Parallel Cable IV

The new Xilinx Parallel Cable IV (PC IV) is a high-speed download cable that configures or programs all Xilinx FPGA, CPLD, ISP PROM, and System ACE MPM devices. The cable takes advantage of the IEEE 1284 ECP protocol and Xilinx iMPACT software to achieve download speeds that are over 10 times faster than the PC III. The cable automatically senses and adapts to target I/O voltages and is able to accommodate a wide range of I/O standards from 1.5V to 5V.

PC IV supports the widely used industry standard IEEE 1149.1 Boundary-Scan (JTAG) specification using a four-wire interface. It also supports the Xilinx Slave Serial mode for Xilinx FPGA devices. It

interfaces to target systems using a ribbon cable that features integral alternating ground leads to reduce noise and increase signal integrity.

The cable is externally powered from either a power brick or by interfacing to a standard PC mouse or keyboard connection. A bi-color status LED indicates the presence of operating and target reference voltages.

Connecting to Host Computer

The PC IV connects to any PC using Win2000, Win XP, or through the standard IEEE 1284 DB25 parallel (printer) port connector. To fully utilize the higher speeds of this cable, the host PC must have a parallel port that supports extended capability port (ECP) mode. If ECP mode is not enabled, the PC IV defaults to compatibility mode and does not run at the optimum speeds listed.

Cable Power

The host interface cable (Figure 2-3) includes a short power jack for connection to one of two possible +5V DC power sources: (1) an external AC adapter or (2) the keyboard or mouse port of the host PC (shown). The supplied power splitter cable is required when using the second option. The splitter cable is installed between the mouse cable and the standard 6-pin mini-DIN (PS2) connector on the host PC. PC IV operating current is less than 100 mA. It draws approximately 15 mA from the target board's reference voltage supply to power the JTAG/Slave Serial buffers.

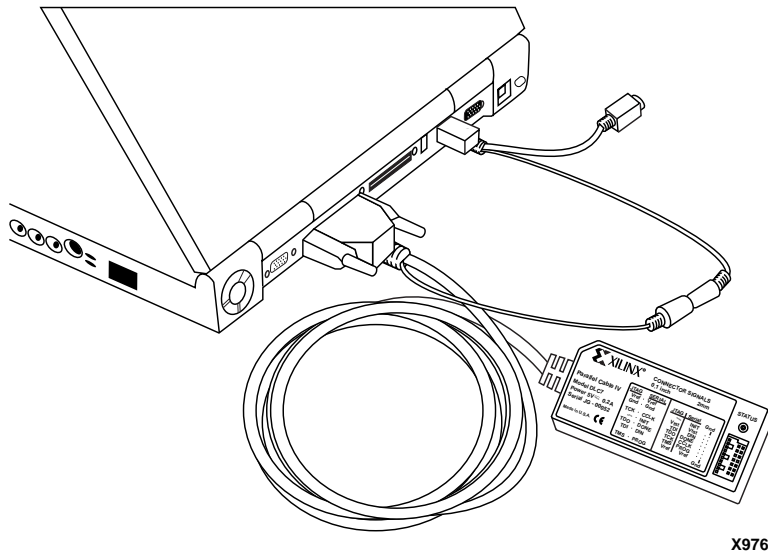

X9762

Figure 2-3 Parallel Cable IV Parallel and PS2 Connection

High Performance Ribbon Cable

An insulation displacement (IDC) ribbon cable is supplied and recommended for connection to target systems. This cable incorporates multiple signal-ground pairs and facilitates error-free connection. A very small footprint, keyed mating connector is all that is required on the target system.

The Parallel Cable IV can also interface to target systems using flying lead wires. However, these are not included with PC IV and can be purchased separately. The ribbon cable is recommended for new designs to attain optimal speeds.

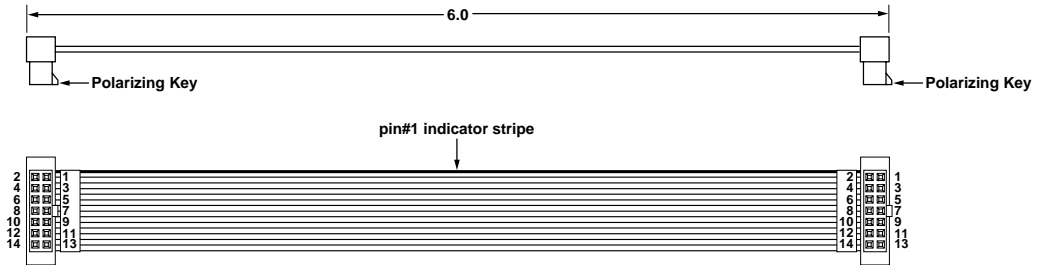

X9760

Figure 2-4 High Performance Ribbon Cable

Note Ribbon Cable - 14 conductor 1.0mm centers Round Conductor Flat Cable; 28 AWG (7x36) stranded copper conductors; gray PVC with pin 1 edge marked.

Note 2mm Ribbon Female Polarized Connectors - IDC connection to ribbon; contacts are beryllium copper plated; 30 micro inches gold plating over 50 micro inches nickel; connectors mate to 0.5mm square posts on 2mm centers.

Target Board Header

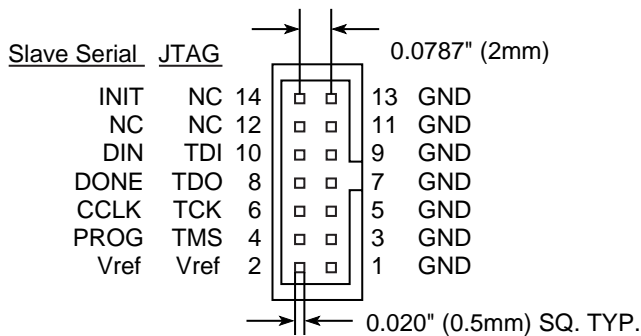

X9776

Figure 2-5 Target Interface Connector Signal Assignments

Table 2-4 Mating Connectors for 2mm pitch, 14 Conductor Ribbon Cable

| Manufacturer | SMT. Vertical | SMT. Right Angle | Through-Hole Vertical | Through-Hole Right Angle |
|---------------------|----------------------|-------------------------|------------------------------|---------------------------------|
| Molex | 87332-1420 | N/A | 87331-1420 | 87333-1420 |
| FCI | 95615-114 | N/A | 90309-114 | 95609-114 |
| Comm Con Connectors | 2475-14G2 | N/A | 2422-14G2 | N/A |

Parallel Cable III

Parallel Cable III

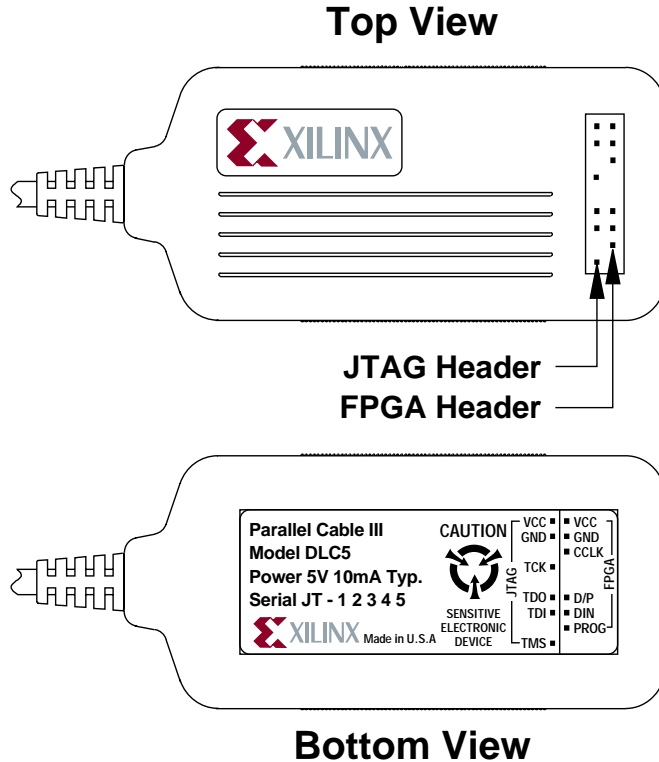

X9759

Figure 2-6 Top and Bottom View of Parallel Download Cable III

The Parallel Download Cable III consists of a cable assembly containing logic to protect your PC's parallel port and a set of headers to connect to your target system. PC III was replaced by PC IV in March 2002 with legacy support from iMPACT.

Using the Parallel Download Cable requires a PC equipped with an AT compatible parallel port interface with a DB25 standard printer connector. Figure 2-6 shows the Parallel Download Cable.

Connecting for System Operation

Connect the parallel cable to the host system and your target system as shown in Figure 2-3.

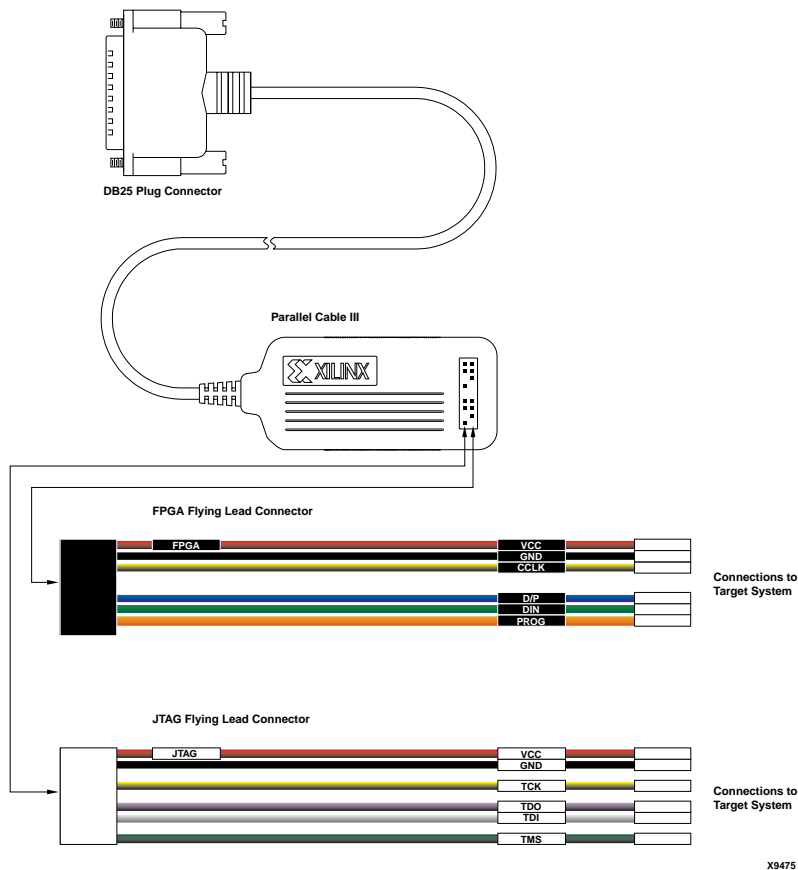
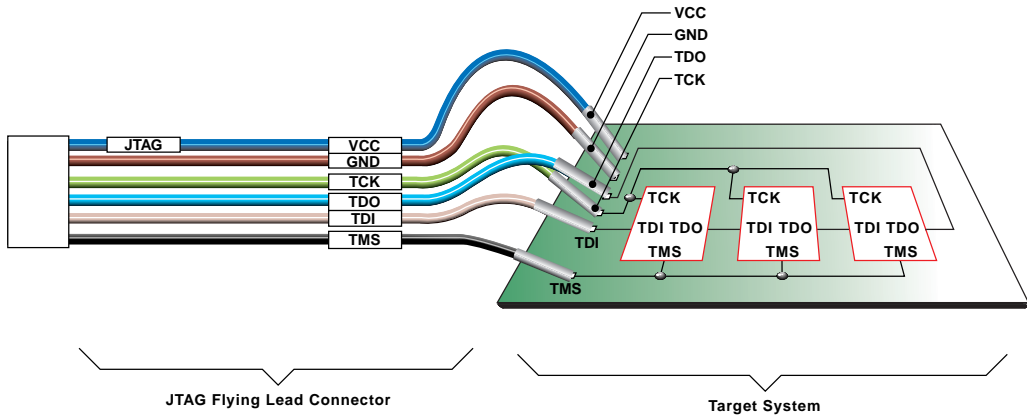

Figure 2-7 Parallel Download Cable III and Accessories

The parallel download cable can download to a single device or several devices connected in either a Boundary-Scan chain or a slave-serial daisy chain (FPGA only). The parallel cable can be used to read back configuration and Boundary-Scan data.

The transmission speed of the Parallel Download Cable is determined solely by the speed at which the host PC can transmit data through its parallel port interface.



X8005

Figure 2-8 Parallel Download Cable Connection to JTAG Boundary-Scan TAP

JTAG parallel cable schematic contains schematic diagrams of the Parallel Download Cable.

Table 2-5 Parallel Cable Connections and Definitions

| Name | Function | Connections |
|------|---|----------------------------|
| Vcc | Power – Supplies Vcc (5 V, 3.3V, or 2.5V, 10 mA, typically) to the cable. | To target system Vcc |
| GND | Ground – Supplies ground reference to the cable. | To target system ground |
| TCK | Test Clock – this clock drives the test logic for all devices on Boundary-Scan chain. | Connect to system TCK pin. |

Table 2-5 Parallel Cable Connections and Definitions

| Name | Function | Connections |
|------|---|----------------------------|
| TDO | Read Data – Read back data from the target system is read at this pin. | Connect to system TDO pin. |
| TDI | Test Data In – this signal is used to transmit serial test instructions and data. | Connect to system TDI pin. |
| TMS | Test Mode Select – this signal is decoded by the TAP controller to control test operations. | Connect to system TMS pin. |

Serial Configuration Connection

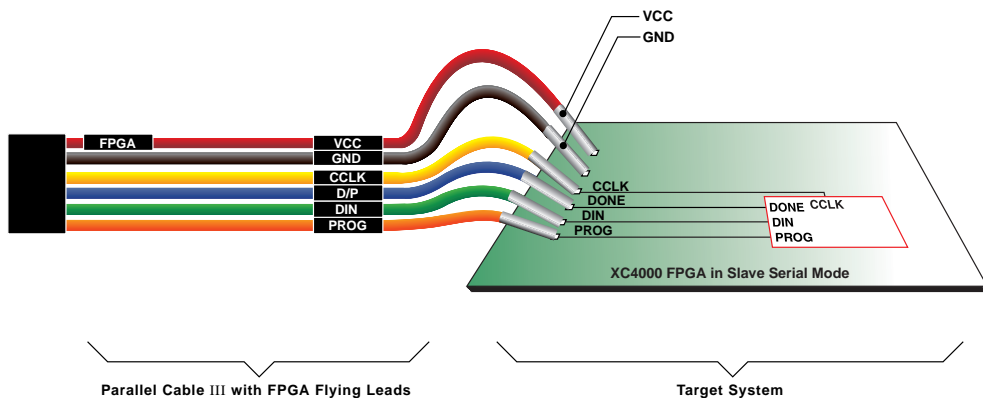

X8326

Figure 2-9 Parallel Cable III Connections

Table 2-6 Parallel Cable Connections and Definitions

| Name | Function | Connections |
|-------------|--|-----------------------------|
| Vcc | Power – Supplies Vcc (5 V, 3.3V, or 2.5V, 10 mA, typically) to the cable. | To target system Vcc |
| GND | Ground – Supplies ground reference to the cable. | To target system ground |
| CCLK | <i>Configuration Clock</i> --- is the configuration clock pin, and the default clock for readback operation. | Connect to system CCLK pin. |
| DONE (D/P) | <i>Done/Program</i> --- Indicates that configuration loading is complete, and that the start-up sequence is in progress. | Connect to system DONE pin. |
| DIN | <i>Data In</i> --- Provides configuration data to target system during configuration and is tristated at all other times. | Connect to system DIN pin. |
| PROG | <i>Program</i> --- A Low indicates the device is clearing its configuration memory. Active Low signal is used to initiate the configuration process. | Connect to system PROG pin. |

MultiPRO Desktop Tool

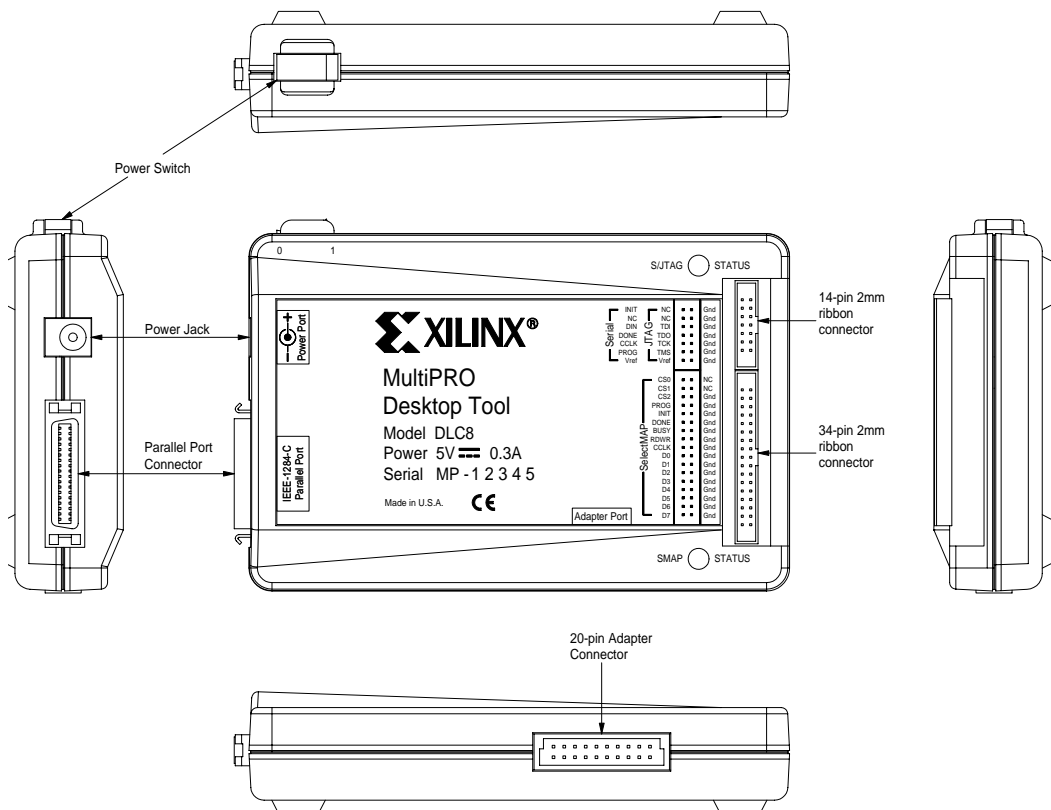

Figure 2-10 MultiPRO Desktop Tool

The new Xilinx MultiPRO is a high-speed desktop download tool that configures all Xilinx FPGA devices and programs all Xilinx CPLD, ISP PROM, and System ACE MPM devices. The cable takes advantage of the IEEE-1284 ECP protocol and Xilinx iMPACT software to achieve download speeds similar to the Parallel Cable IV and is over 10 times faster than the Parallel Cable III. MultiPRO automatically senses and adapts to target I/O voltages and is able to accommodate a wide range of I/O standards from 1.5V to 5V.

The MultiPRO can also function as a desktop programmer, similar to the Xilinx HW-130 when the appropriate programming adapter is connected to the MultiPRO's 20-pin adapter port. Using these

adapters, MultiPRO supports desktop programming of the CoolRunner-II CPLD family, the XC18V00 ISP PROM family. For more information, see the “[Desktop Programming](#)” section of this chapter.

MultiPRO supports the widely used industry standard IEEE 1149.1 Boundary-Scan (JTAG) specification using a four-wire interface. It also supports the Xilinx Slave Serial mode and SelectMAP mode for Xilinx FPGA devices. It interfaces to target systems using ribbon cables that feature alternating ground leads to reduce noise and increase signal integrity.

An IEEE-1284 parallel cable is supplied to interface between the MultiPRO Desktop Tool and any PC with a parallel port (See Figure 2-11). The cable uses a standard DB25 male connector for the PC. When attaching or disconnecting the parallel cable to the MultiPRO Desktop Tool, squeeze the parallel cable’s connector to open the locking tabs.

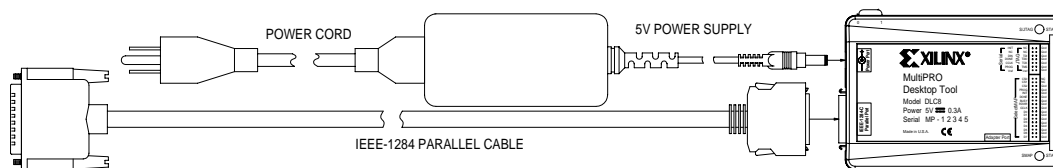

Figure 2-11 IEEE-1284 Parallel Cable and 5V Power Supply

MultiPRO is externally powered from a 5V universal power supply that is included. The power supply’s 5.5x2.1mm DC plug is connected to the MutliPRO’s power port jack. The power supply has a detachable power cord that allows different style AC plugs to be used.

Two bi-color status LEDs indicate the presence of operating and target reference voltages. The LED labeled S/JTAG STATUS is associated with the 14 conductor ribbon cable used with the Slave Serial and JTAG modes of operation. The LED labeled SMAP STATUS is associated with the 34 conductor ribbon cable used with the SelectMAP mode of operation. Both STATUS indicators illuminate amber color when the 5V supply is connected and the MultiPRO power switch is turned on. The S/JTAG STATUS indicator will change color to green when the target reference voltage from the 14 conductor ribbon cable is present (1.5V to 5V). The SMAP STATUS

indicator will change color to green when the target reference voltage from the 34 conductor ribbon cable is present (1.5V to 5V).

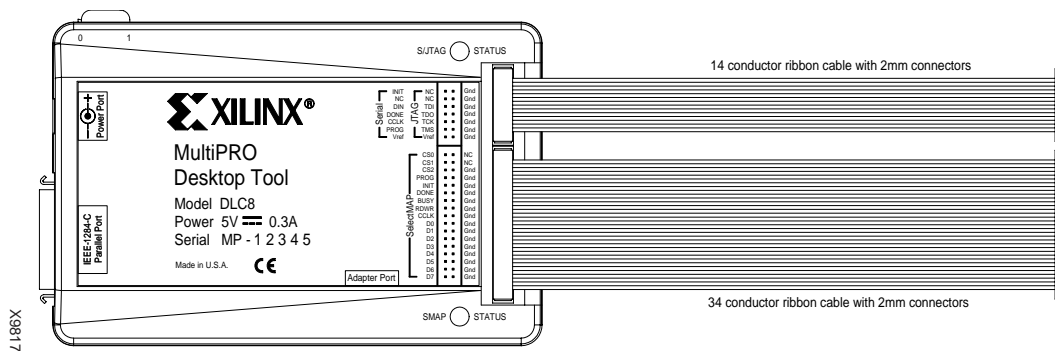

Figure 2-12 Ribbon Cables Connected to MultiPRO

Connecting to Host Computer

The MultiPRO Desktop Tool connects to any PC using Win2000 or WinXP through the standard IEEE-1284 DB25 parallel (printer) port connector. To fully utilize the higher speeds of this cable, the host PC must have a parallel port that is enabled to support extended capability port (ECP) mode. If ECP is not enabled, the MultiPRO will default to compatibility mode and will not run at the optimum speeds listed. While in compatibility mode, the MultiPRO will also not support SelectMAP nor the programming adapters. Compatibility mode simulates the operation of a Parallel Cable III using only the Slave Serial/JTAG functions.

Cable Power

The universal 5V switching power supply, included with the MultiPRO, can accept input voltages from 100 to 240VAC at 46 to 63 Hz. The MultiPRO takes less than 300mA from the 5V supply. MultiPRO's load on the target board's reference voltage supply for the Slave Serial/JTAG or SelectMAP connection is less than 1mA.

High Performance Ribbon Cables

Insulation displacement (IDC) ribbon cables are supplied and are the only means of connection to the target system. The MultiPRO does

not support the use of Xilinx “flying lead” wires. These cables incorporate multiple signal-ground pairs and facilitate error-free connections. A small footprint, keyed mating connector is all that is required on the target system.

The 14 conductor ribbon cable, used for MultiPRO’s Slave Serial & JTAG connection, is identical to the one used with Parallel Cable IV.

The 34 conductor ribbon cable, used for MultiPRO’s SelectMAP connection, is shown in Figure 2-13 below. See figure 2-14 for the appropriate connector pin assignments and sample vendor part number.

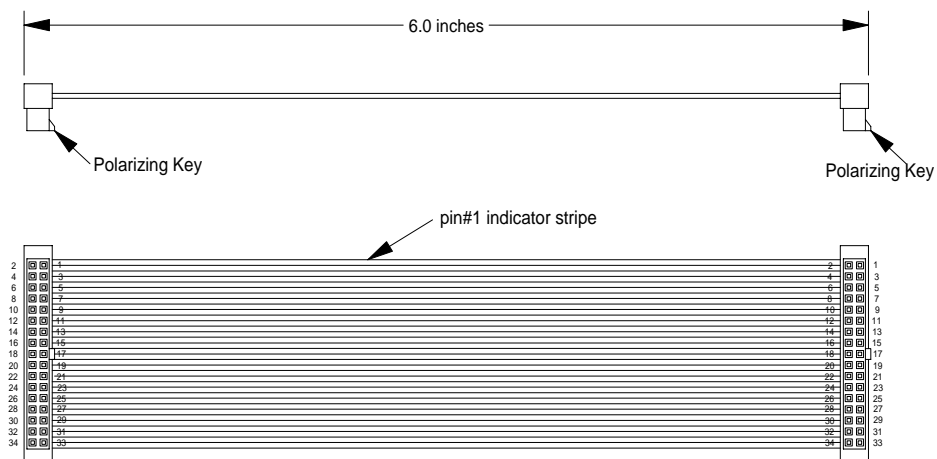

NOTES:

1. RIBBON CABLE - 34 conductor
 1.0mm Round Conductor Flat Cable
 28AWG (7x36) stranded copper conductors
 Gray PVC with pin #1 edge marked.
2. 2mm Ribbon Female Polarized Connectors
 IDC connection to ribbon
 Contacts are beryllium copper plated
 30 micro inches Gold plating over 50 micro inches Nickel
 Connectors mate to 0.5mm square posts on 2mm centers.

X9818

Figure 2-13 34 Conductor Ribbon Cable

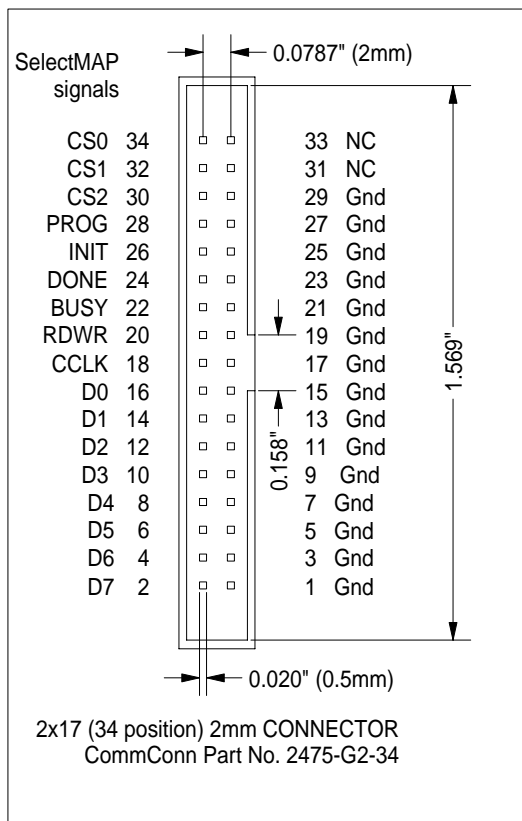

Figure 2-14 Connector Pin Assignments for 34 Conductor Ribbon Cable

Desktop Programming

The MultiPRO can be used as a desktop programmer, similar to the Xilinx HW-130 Programmer, to program Xilinx CPLDs and ISP PROMs. Optional adapters can be purchased separately and plugged into the 20 pin Adapter Port connector of the MultiPRO (See Figure 2-15).

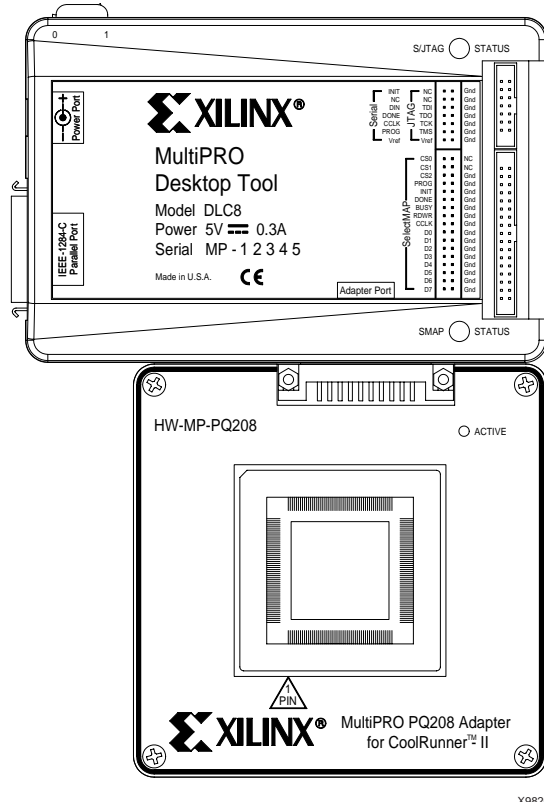

Figure 2-15 MultiPRO Adapter

The MultiPRO programming adapters currently support the CoolRunner-II CPLD family and the XC18V00 ISP PROM family (see Table 2-7). The device adapters for the HW-130 and the MultiPRO are physically incompatible.

The red LED labeled “ACTIVE” on the adapters is illuminated when the device is busy being programmed. Do not remove a device from

its socket nor unplug the adapter from MultiPRO when the “ACTIVE” LED is illuminated.

Table 2-7 Available Adapters for MultiPRO

| XC18V00 ISP PROM Family | | |
|---------------------------------------|----------------|----------------------------|
| Device | Package | Adapter Part Number |
| 18V256, 18V512, 18V01 | PC20 | HW-MP-PC20 |
| 18V256, 18V512, 18V01 | SO20 | HW-MP-SO20 |
| 18V02, 18V04 | PC44 | HW-MP-PC44-1 |
| 18V256, 18V512, 18V01 18V02, 18V04 | VQ44 | HW-MP-VQ44-1 |
| CoolRunner-II CPLD Family | | |
| Device | Package | Adapter Part Number |
| 2C32, 2C64 | PC44 | HW-MP-PC44-2 |
| 2C32, 2C64 | VQ44 | HW-MP-VQ44-2 |
| 2C32, 2C64 | CP56 | HW-MP-CP56 |
| 2C64, 2C128, 2C256 | VQ100 | HW-MP-VQ100 |
| 2C128, 2C256 | CP132 | HW-MP-CP132 |
| 2C128, 2C256, 2C384 | VQ144 | HW-MP-VQ144 |
| 2C256, 2C384, 2C512 | PQ208 | HW-MP-PQ208 |
| 2C256, 2C384, 2C512 | FT256 | HW-MP-FT256 |
| 2C384, 2C512 | FG324 | HW-MP-FG324 |

MultiLINX Cable

Figure 2-16 shows the top and bottom view of the MultiLINX Cable.

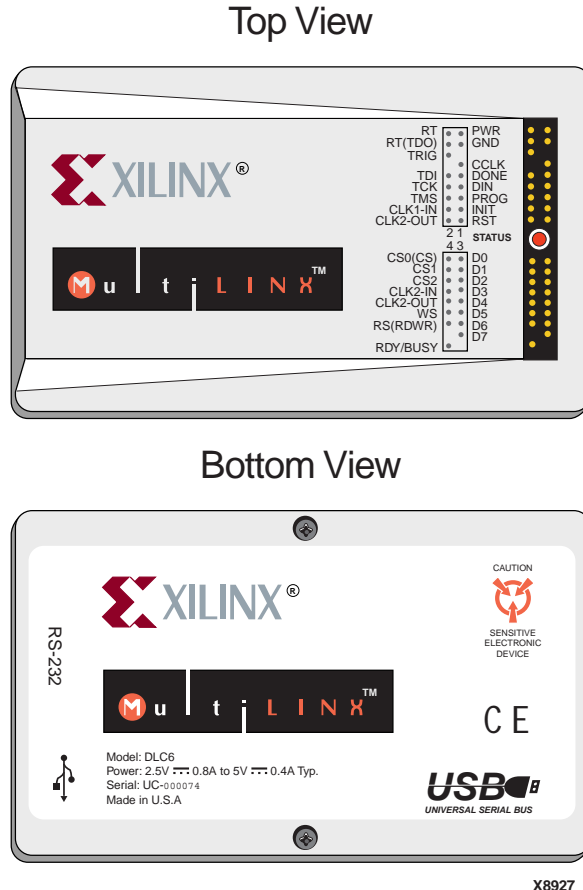

Figure 2-16 MultiLINX Cable

You can use the MultiLINX Cable to download and verify all Xilinx CPLDs and FPGAs. The MultiLINX Cable hardware communicates with the host over the Universal Serial Bus (USB) or at variable baud rates over an RS-232 interface at up to 57600 BITS/sec.

You can access the following application notes with descriptions of device-specific design techniques and approaches from the support page at (<http://support.xilinx.com/support/searchtd.htm>).

“Getting Started with the MultiLINX Cable” application note #168 is a quick reference to everything you need to know to use the MultiLINX Cable, including using a USB device, Mixed Voltage environments, and connections for all the supported Modes.

MultiLINX Power Requirements

The MultiLINX Cable gets its power from the User’s circuit board. The cable power does not come from the USB port (nor the RS-232 port). The red (PWR) and black (GND) wires from Flying Wire Set #1 are connected to the Vcc (red wire) and Ground (black wire) lines of the circuit board that is powering the Xilinx device.

The minimum input voltage to the cable is 2.5 V (.8 A). The maximum input voltage is 5 V (.4 A).

MultiLINX Cable and Flying Leads

The MultiLINX Cable is shipped with four sets of flying lead wires. A USB Cable and RS-232 Cable (with adapter) are also supplied.

Figure 2-17 shows the MultiLINX Cable hardware and flying lead connection wires.

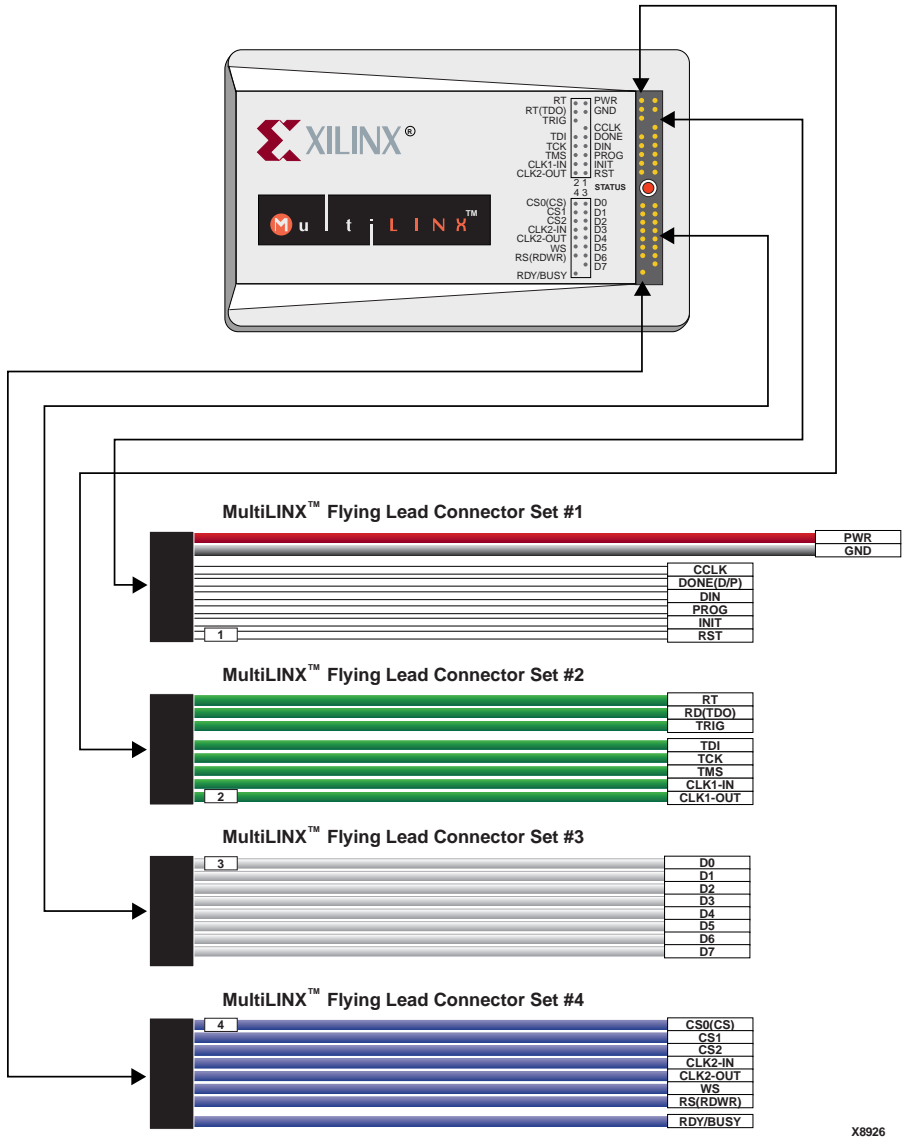

Figure 2-17 MultiLINX Cable and Flying Lead Connectors

The MultiLINX Flying wires are described in the following tables.

Table 2-8 MultiLINX Pin Descriptions (Flying Lead Set #1)

| Signal Name | Function |
|-------------|---|
| PWR | <i>Power</i> - Supplies Vcc to cable (Works at multiple voltages 5V, 3.3V, and 2.5V). |
| GND | <i>Ground</i> - Supplies ground reference to cable. |

Table 2-9 MultiLINX Slave Serial Pin Descriptions (Flying Lead Set #1)

| Signal Name | Function |
|-------------|---|
| CCLK | <i>Configuration Clock</i> - is the configuration clock pin, and the default clock for readback operation. |
| DONE (D/P) | <i>Done/Program</i> - Indicates that configuration loading is complete, and that the start-up sequence is in progress. |
| DIN | <i>Data In</i> - Provides configuration data to target system during configuration and is tristated at all other times. |
| PROG | <i>Program</i> - A Low indicates the device is clearing its configuration memory. Use the Active Low signal to initiate the configuration process. |

**Table 2-9 MultiLINX Slave Serial Pin Descriptions
(Flying Lead Set #1)**

| Signal Name | Function |
|-------------|---|
| INIT | <i>Initialize</i> — Initialization sequencing pin during configuration (indicates start of configuration). A logical zero on this pin during configuration indicates a data error. |
| RST | <i>Reset</i> — Pin used to reset internal FPGA logic. Connection to this pin is optional during configuration. |

**Table 2-10 MultiLINX Boundary-Scan Pin Descriptions
(Flying Lead Set #2)**

| Signal Name | Function |
|-------------------|---|
| RD (TDO) | <i>Read Data</i> — MultiLINX input. iMPACT receives the readback data through the RD pin after readback is initiated. Pin used to initiate a readback of target FPGA. TDO is for JTAG (Boundary-Scan). |
| TDI TCK TMS | These pins are used for JTAG (Boundary-Scan) device configuration. The JTAG/Boundary-Scan pins function for FPGA, CPLD, ISP PROM, and SystemACE MPM operations. |

**Table 2-11 MultiLINUX SelectMAP Pin Descriptions
(Flying Lead Sets 3&4)**

| Signal Name | Function |
|-------------|--|
| D0-D7 | <i>Data Bus</i> — This pin is used for Virtex SelectMAP Mode. An 8 BIT data bus supporting the SelectMAP and Express configuration modes. |
| CS0 (CS) | <i>Chip Select</i> — CS on the Virtex. The CS0/CS pin represents a chip select to the target FPGA during configuration. |
| CS1 | <i>Chip Select</i> — The CS1 pin represents Chip Select to FPGAs during configuration. |
| CS2 | <i>Chip Select</i> — The CS2 pin represents Chip Select to the FPGA while using the Peripheral configuration mode. |
| WS | <i>Write Select</i> — The WS pin represents Write Select control for the Asynchronous Peripheral configuration mode. |
| RS (RDWR) | <i>Read Select</i> — The RS pin represents Read Select control for the Asynchronous Peripheral configuration mode. <i>Read/Write</i> — The RDWR pin is used as an active high READ and an active low WRITE control signal to the Virtex FPGA. |
| RDY/BUSY | <i>Busy Pin</i> — Busy pin on the Virtex. |

MultiLINX Connection and Power Sequence

The following considerations should be followed when powering up the MultiLINX cable.

Caution Connecting the MultiLINX leads to the wrong signal causes permanent damage to the MultiLINX internal hardware. You must connect PWR to Vcc and GND to ground. As with any CMOS device, the input/output pins of the internal FPGA should always be at a lower or equal potential than the rail voltage to avoid internal damage. The cable draws its power from the target system through Vcc and GND. Therefore, power to the cable, as well as to the target FPGA, must be stable. Do not connect any signals before connecting Vcc and GND.

Connecting Cable to Target System

This section covers cable connection to the target device. You need appropriate pins on the target system for connecting the target system board to the header connectors on the cable.

1. Connect your cable to your host computer. If you have a MultiLINX Cable, connect it to the USB or RS-232 port. A DB-9/DB-25 adapter may be required to connect the cable to your serial port. If you have a different serial port connection, you need to use the appropriate adapter.
2. Turn the power to your target system off, if possible.
3. The power for the drivers is derived from the target system. Connect the cable's GND wire to the corresponding signal on the target board. Next, connect Vcc to the corresponding signal on the target board.
4. Download cables do not operate if the target system's power is turned off before or during iMPACT Configuration operations. Make certain that this power connection is on and stable. Your system's power should be on during iMPACT Configuration operations.
5. Next, connect the signal leads.

Note When using Boundary-Scan connections, please note that TRST is not supported by Xilinx Download Cables. If any of your JTAG parts have a TRST pin, it should be connected to Vcc.

6. Turn on power to the target system.
7. Make sure Vcc rises to a stable level within 10ms. After the cable Vcc stabilizes, the level should be within 5% of the target systems Vcc IO.

Designing Boundary-Scan and ISP Systems

This chapter gives design considerations for Boundary-Scan and ISP systems.

This chapter contains the following sections.

- “Connecting Devices in a Boundary-Scan Chain”
- “FPGA Device Considerations”
- “Selecting a Configuration Mode”
- “Programming and Configuring Options”
- “Xilinx Common Configuring and Programming Setups”
- “Virtex Series or Spartan-II Master Serial and Boundary-Scan (JTAG) Combination Setup”
- “Configuration Checklist”

Connecting Devices in a Boundary-Scan Chain

All devices in the chain share the TCK and TMS signals. The system TDI signal is connected to the TDI input of the first device in the Boundary-Scan chain. The TDO signal from that first device is connected to the TDI input of the second device in the chain and so on. The last device in the chain has its TDO output connected to the system TDO pin. This configuration is illustrated in Figure 3-1.

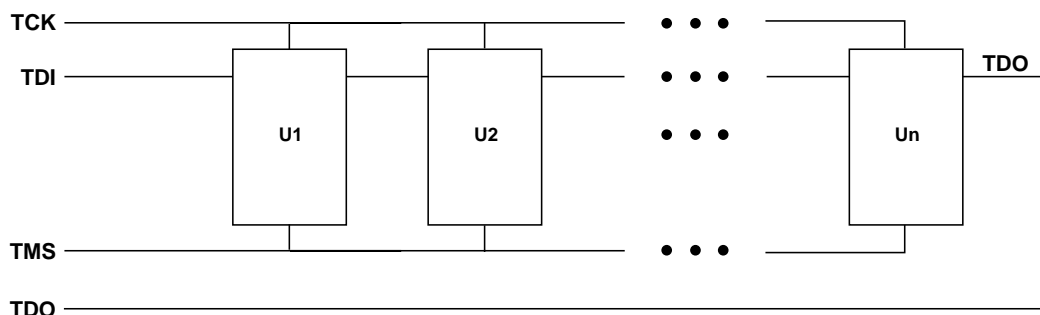

X9855

Figure 3-1 Single Port Serial Boundary-Scan Chain

The Boundary-Scan standard requires pull-up resistance to be supplied internally to the TDI and TMS pins by the chips, but no particular value is required. Vendors supply whatever they choose and still remain in full compliance. Therefore, very long Boundary-Scan chains, or chains using parts from multiple vendors, may present significant loading to the ISP drive cable. In these cases:

- Use the latest Xilinx download cables (parallel cables or Multi-LINX cable).
- Consider including buffers on TMS or TCK signals interleaved at various points on your JTAG circuitry to account for unknown device impedance.
- Some users have noted that their designs appear to experience erase time or programming time extension as the design progresses, particularly for long chains. This is probably due to switching noise.
- Put the rest of the JTAG chain into HIGHZ mode by selecting the HIGHZ preference in the iMPACT Edit → Preferences dialog box when programming a troublesome part.
- If free running clocks are delivered into Boundary-Scan devices, it may be necessary to disconnect or disable their entry into these devices during ISP or Boundary-Scan operations.
- Charge pumps, the heart of the XC9500/XL/XV ISP circuitry, require a modest amount of care. The voltages to which the pumps must rise are directly derived from the external voltage

supplied to the VccINT pins on the XC9500/XL/XV parts. Because these elevated voltages must be within their prescribed values to properly program the CPLD, it is vital that they be provided with very clean (noise free) voltage within the correct range. This suggests the first two key rules:

- Make sure Vcc is within the rated value for the devices you are using.
- Provide both 0.1mF and 0.01 mF capacitors at every Vcc point of the chip, and attach directly to the nearest ground.

FPGA Device Considerations

iMPACT supports the configuration of Xilinx FPGA devices through the Boundary-Scan test access port (TAP). In order to enable Boundary-Scan-based configuration capabilities for FPGA devices, you must design your systems and prepare your configuration bitstreams in the following manner.

Bitstream Considerations

Express mode bitstreams cannot be used to configure devices via Boundary-Scan.

Keep your device bitstream files separate for each device in the Boundary-Scan chain. iMPACT requires you to assign a single BITfile to each device. It cannot manipulate composite BIT files in Boundary-Scan mode.

Virtex Considerations

When generating bitstreams for Virtex devices, always select the option to choose the JTAG clock as the startup clock. iMPACT notifies you if this is set incorrectly and gives you the option of correcting it in the memory image of the bitstream.

Note The source bitstream will not be corrected. You must rerun BitGen to correct the source bitstream.

Device Behavior Notes

The implementation of Boundary-Scan based configuration of FPGAs precludes the use of concurrent ISP. For this reason, the concurrent

mode preference is disabled (or ignored) when FPGAs are selected to be operated upon.

Selecting a Configuration Mode

Before deciding on the configuration environment, it is important to be aware of the available configuration modes. The following table shows the modes supported by each family with a description of each mode following the table.

Table 3-1 Modes Supported (by Family)

| Family | JTAG | SelectMAP / Slave-Parallel | Master-Serial | Slave-Serial | Standalone Programmer |
|--|------|----------------------------|---------------|--------------|-----------------------|
| Virtex/E/II/III-PRO Families (FPGA) | X | X | X | X | |
| CoolRunner Families (CPLD) | X | | | | X* |
| Spartan/II/II-E Families (FPGA) | X | Spartan-II/II-E only | X | X | |
| XC9500/XL/XV Families (CPLD) | X | | | | X |
| XC18V00 Family (PROM) | X | | | | X* |
| XC17S00 Family (PROM) | | | | | X |

*Supported by iMPACT Desktop Configuration Mode

FPGA Supported Modes

JTAG or Boundary-Scan Mode

JTAG or Boundary-Scan mode is an industry standard (IEEE 1149.1, or 1532) serial programming mode supported by iMPACT. External logic from a cable, microprocessor, or other device is used to drive the JTAG specific pins, Test Data In (TDI), Test Mode Select (TMS), and Test Clock (TCK). This mode has gained popularity due to its standardization and ability to program FPGAs, CPLDs, and PROMs through the same four JTAG pins. The data in this mode is loaded at one BIT per TCK.

SelectMAP/Slave-Parallel Modes

SelectMAP mode is supported by the Virtex families, and Slave-Parallel mode is supported by the Spartan-II family, as well as by iMPACT. SelectMAP/Slave-Parallel modes allow parallel reading and writing through byte-wide ports. An external clock source, microprocessor, download cable or other FPGA is required. The data is loaded one byte per CCLK in this mode. This mode is typically used as a configuration mode on Virtex, Virtex-II or Spartan-II devices when configuration speed is an important factor.

Master SelectMAP Mode

Master SelectMAP mode is a master version of the SelectMAP mode. The device is configured byte-wide on a CCLK supplied by the Virtex-II Pro FPGA device. Timing is similar to the Slave SerialMAP mode except that CCLK is supplied by the Virtex-II Pro FPGA.

Master-Serial Mode

Master-Serial mode is supported by all Xilinx FPGA families, but not Xilinx CPLDs, nor by iMPACT. It is the simplest configuration method for FPGAs. The FPGA loads configuration data from a serial PROM. Using the FPGA to provide the clock, it virtually loads itself and utilizes its internal oscillator, which drives the configuration clock. The FPGA provides all the control logic. In this mode, data is loaded at one BIT per CCLK.

Slave-Serial Mode

Slave-Serial mode, like Master-Serial, is supported by all Xilinx FPGA families, but not Xilinx CPLDs. It uses an external clock and allows for daisy-chain configurations. In this mode, an external clock, such as a microprocessor, another FPGA, or download cable is required. Data in this mode is loaded at one BIT per CCLK. Slave Serial mode is supported by iMPACT.

CPLD/PROM Supported Modes

Standalone Programmer Mode

Standalone Programmer mode is supported by Third Party Programmers, and for some devices in the MultiPRO Desktop Programming Cable.

JTAG or Boundary-Scan Mode

JTAG or Boundary-Scan mode is an industry standard (IEEE 1149.1, or 1532) serial programming mode. External logic from a cable, microprocessor, or other device is used to drive the JTAG specific pins, Test Data In (TDI), Test Data Out (TDO), Test Mode Select (TMS), and Test Clock (TCK). This mode has gained popularity due to its standardization and ability to program FPGAs, CPLDs, and PROMs through the same four JTAG pins. The data in this mode is loaded at one BIT per TCK.

Programming and Configuring Options

The next section gives an overview of all configuration or programming flows for each family.

CPLD Programming Options

The CPLD programming flow starts after the CPLD fitter software generates the **JEDEC** file. The following chart shows the options available for downloading the **JEDEC** file into the CPLD device.

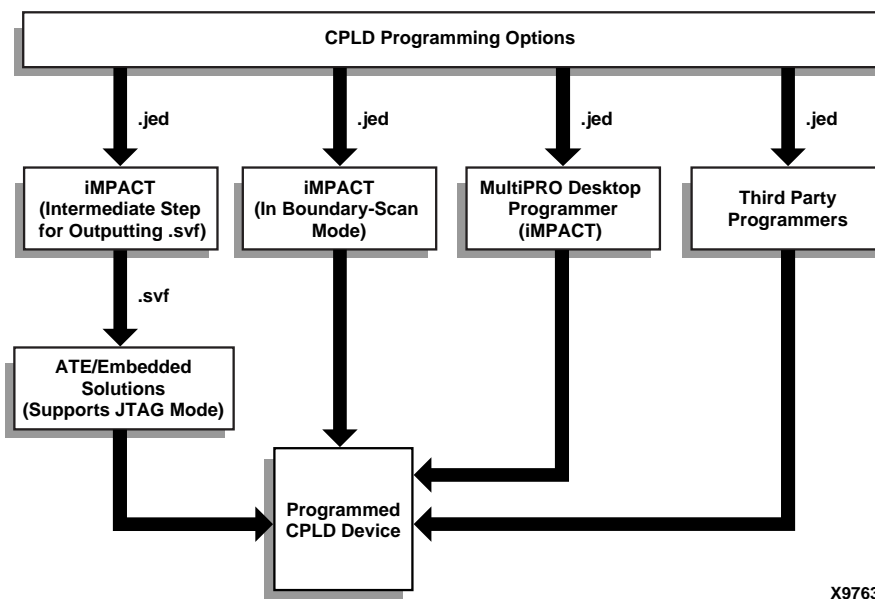

Figure 3-2 CPLD Programming Options

ATE/Embedded Solutions

Embedded solutions are becoming very popular as board densities increase and microprocessors become commonplace in many systems. For examples of how to use Xilinx CPLDs in ATE or embedded systems, see the websites at: <http://www.xilinx.com/isp/ate.htm> and <http://www.xilinx.com/isp/ess.htm>

MultiPRO Desktop Programmer

MultiPRO is the Xilinx desktop programmer. Primarily an upgrade from the HW130, the MultiPRO cable is a multi-function tool capable of ISP configuration using JTAG, Slave-Serial, or SelectMAP interfaces. Ribbon cables can be simultaneously attached to an ISP target system.

Third Party Programmers

Third Party Programmers, such as Data I/O and BP Microsystems, support many Xilinx CPLD's. For details on available third party support, see the website at: <http://www.xilinx.com/support/programr/ps.htm>

FPGA Configuration Flows

Refer to Table 3-1 for the software packages available to generate FPGA bitstreams. The following chart shows several options for downloading the bitstream into the FPGA device.

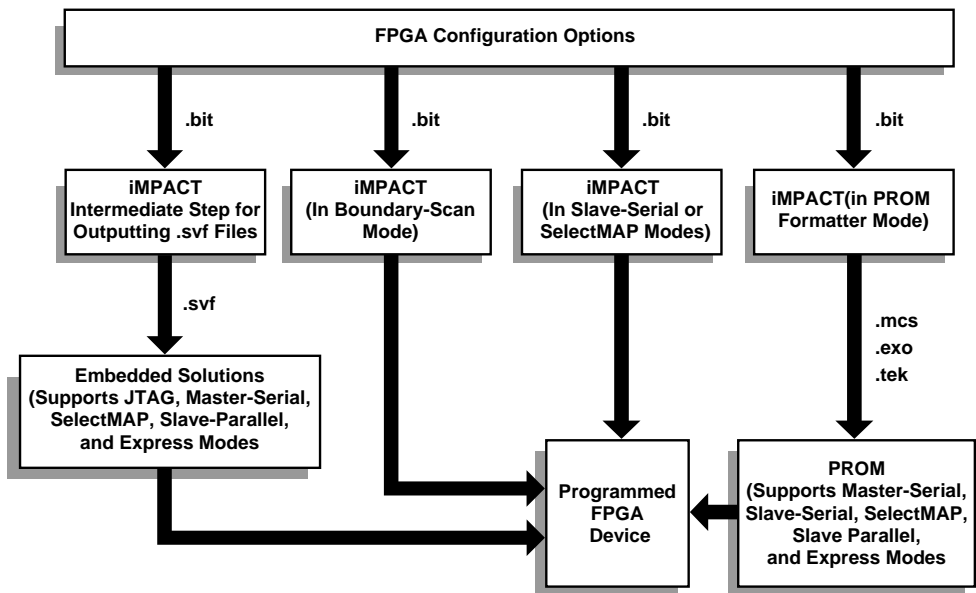

X9856

Figure 3-3 FPGA Configuration Options

Embedded Solutions

Embedded solutions are becoming very popular as board densities increase and microprocessors become commonplace in many systems. For examples of using Xilinx FPGA devices in embedded systems, see the website at: http://www.xilinx.com/xlnx/xil_prodcart_product.jsp?title=isp_ess_page

PROM

A PROM is a companion memory device to the FPGA. Configuring the FPGA from a PROM is one of the most widely used configuration methods. The PROM must be configured with the data intended for the FPGA. When the PROM is placed in the system, the FPGA configures itself from the memory device. This method supports Master-Serial, Slave-Serial, SelectMAP, Slave-Parallel, and Express modes.

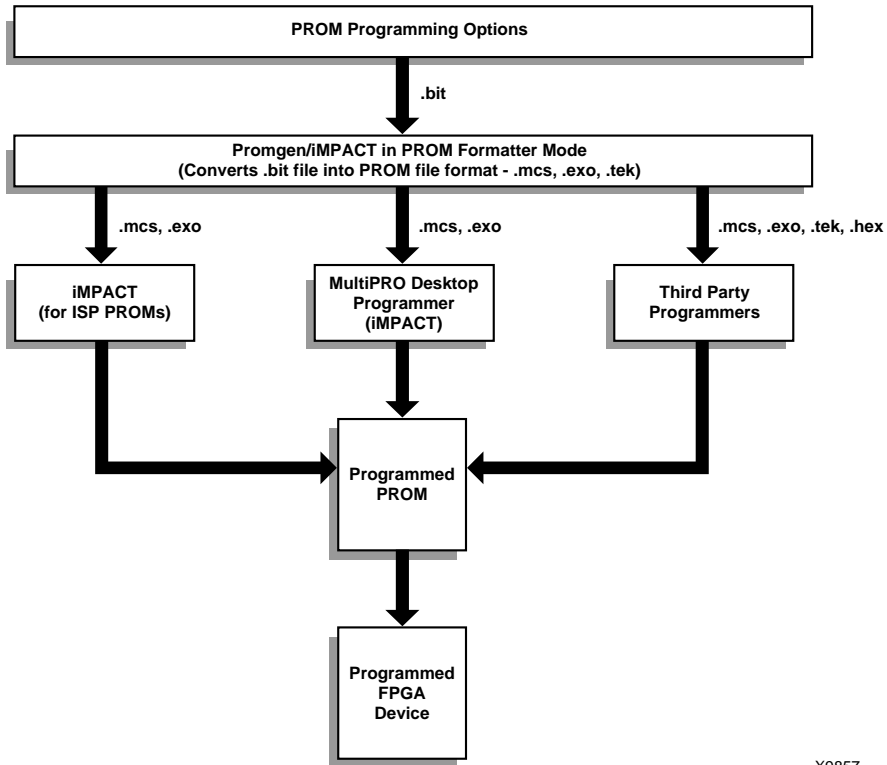

X9857

Figure 3-4 PROM Programming Options

PROMGen/PROM Formatter

PROMGen or the PROM Formatter mode of iMPACT are software tools that create PROM files for serial or byte-wide configuration

PROMs. These tools convert **.bit** files into one of three popular standard PROM file formats: **.mcs**, **.exo**, or **.tek**.

The PROM Formatter tab of iMPACT's File Generation mode provides a (GUI) version of the PROMGen command line software.

Third Party Programmers

Third Party Programmers, such as Data I/O and BP Microsystems, support many Xilinx CPLDS. For details on available third party support, see the website at: <http://www.xilinx.com/support/programr/ps.htm>

Xilinx Common Configuring and Programming Setups

This section provides the Xilinx user a quick summary of some of the more common configuration and programming setups. There are many other methodologies for configuring Xilinx devices. The following setups are commonly used to allow for easy prototyping of robust production setups. A brief description of the setup advantages, required software and hardware, and hardware connections is provided for each setup.

CPLD JTAG Chain Setup

The CPLD JTAG Chain is the most common programming method for CPLDs, since it can be used for both prototyping and production environments.

Advantages:

In-System Programming support

Requires only the four JTAG pins to configure and test the chain

Hardware Used:

Combination of Xilinx CPLD devices (XC9500/XL/XV, XPLA3, CoolRunner-II).

For Prototyping: Xilinx Cable (Parallel III, IV or MultiLINX)

For Production: Microprocessor (Embedded Solution), Automatic Test Equipment (ATE), or Third Party Programmer

Software Used:

Xilinx CPLD programming **JEDEC** files.

For Prototyping: iMPACT Software in Boundary-Scan mode

For Production: Xilinx CPLD programming **JEDEC** files are converted to Xilinx Serial Vector Files (.svf) for use with a microprocessor, ATE, or Third Party Programmer.

Hardware Considerations

The connections to implement a CPLD JTAG chain are shown in the Figure below.

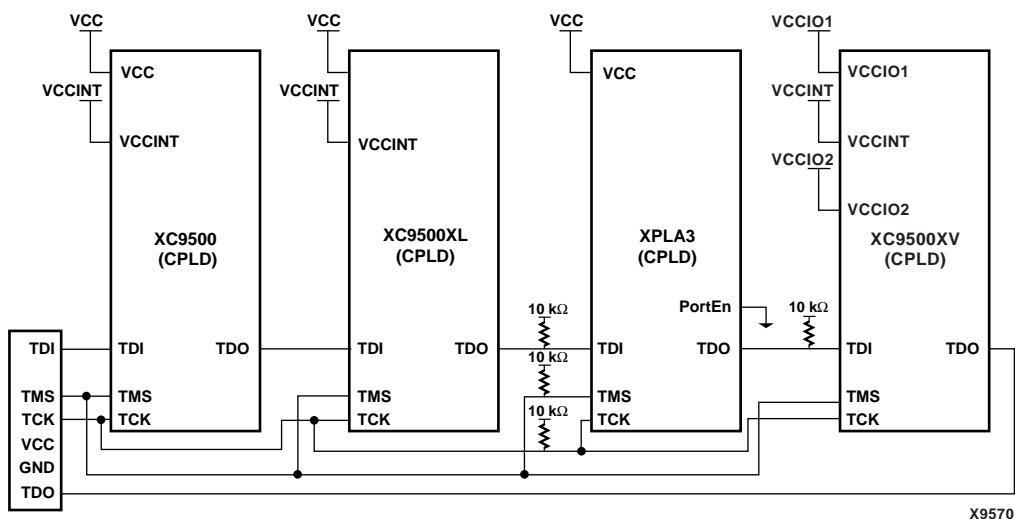

Figure 3-5 CPLD JTAG Chain Connections

When using a JTAG Chain with mixed voltage devices, extra care must be taken to ensure the integrity between the devices. Refer to the device's data sheet for the appropriate voltage operating ranges. In this example, using a 5 V, 3.3 V, and 2.5 V device in a single JTAG chain, although not as typical, allows consideration for a mixed voltage chain to be discussed.

To accommodate both the XC9500 (5 V) and XC9500XV (2.5 V) devices, the VccIO signals should be tied to 3.3 V. This drives the

TDO pin on all of the devices at 3.3 V, which meets the voltage requirements. For the 9500XV, only the VccIO bank (1 or 2) where the TDO pin is located needs to be driven at 3.3 V.

When using a cable with this setup, it should be driven at 3.3 V. This ensures that the TMS and TCK TAP pin values are within the required voltage ranges for all of the specified devices. Since the 5 V part receives slightly lower but acceptable signal levels, good signal integrity is another practice that should be given appropriate consideration. Refer to the following sections for tips and techniques to ensure proper integrity strength and general practices on implementing a CPLD JTAG chain.

General JTAG Checklist

Include buffers on TMS and TCK signals interleaved at various points for larger JTAG chains of more than five devices to account for unknown device impedance.

Make sure the Vcc is within the rated value: 5 V \pm 5% for the XC9500 device, 3.3 V \pm 10% for XC9500XL/XPLA3 devices, and 2.5 V \pm 10% for the XC9500XV device.

Provide both 0.1 mF and 0.01 mF capacitors at every Vcc point of the chip and attach them directly to the nearest ground.

XC9500/XL/XV Specific Checklist

The TDI and TMS (JTAG) pins have internal pullups for the XC9500/XL/XV families and do not require any external pullups since the pins are dedicated for JTAG use.

It is vital that the XC9500/XL/XV devices be provided with very clean (noise free) voltage supplied to the Vcc INTpins within the correct range.

The JTAG Clock for the XC9500/XL devices, TCK, has a maximum frequency of 10 MHz.

When deciding the placement of devices in a mixed voltage chain, care should be taken to ensure compatibility. For instance, the XC9500XV parts are not 5 V tolerant, and care should be taken to ensure the device inputs are driven by the appropriate voltage levels.

XPLA3 Specific Checklist

The PortEn pin should be connected to ground when using dedicated JTAG pins as recommended in this programming setup example.

Note: If the JTAG pins need to be used as dual-purpose I/Os, the PortEn pin should be jumpered out. The PortEn pin is driven high to re-establish connection with the JTAG pins.

The XPLA3 JTAG pins should have an external 10 kW resistor placed on them to prevent them from floating.

The JTAG clock for the XPLA3 devices, TCK, has a maximum frequency of 10 MHz.

Software Implementation Considerations

The software **JEDEC** files need to be created to program the devices. In the implementation step, there are several options that can be modified. The only option whose default setting may need to be changed for XC 9500/XL/XV configuration purposes is “Create Programmable GND Pins on Unused I/O.” By default this option is not selected. Check this option to prevent unused I/O from floating and drawing additional power.

For CoolRunner XPLA3 devices, two of the most important options for programming you should be aware of are described below:

“Pull UP Unused I/O pins” – By default, this option is selected. This is the recommended state to prevent additional power draw due to the CMOS I/O.

“Reserve ISP pins” – By default, this option is selected. Deselect this option only if you intend the JTAG pins to be used as dual-purpose I/Os.

Software Download Considerations

The last step needed to complete the implementation of a CPLD JTAG Chain is programming the bitstream to the device. With the JTAG Chain programming, this can be done for both prototyping and production environments.

Prototyping Environment

In a prototyping environment, it is very common to use a Xilinx programmer, which comprises a stand-alone downloadable software module that requires a Xilinx cable and access to the JTAG pins of the devices.

Production Environment

In a production environment, ATEs or Third Party Programmers are more common. In general, these tools supply faster programming times, and in many cases, supply a means to program more devices at a given time.

For this environment, a JEDEC file is normally converted into a standard vector format (.svf) file. This file format is a standard widely accepted by vendors and is a common way to distribute programming files. This format is an optional output of the Xilinx programmers described above in the Prototyping section.

Virtex Series or Spartan-II Master Serial and Boundary-Scan (JTAG) Combination Setup

Master Serial mode and Boundary-Scan (JTAG) mode are two of the most commonly used configuration modes for the Virtex Series and Spartan-II devices.

- **Advantages:**
 - ◆ The combination of the Master-Serial mode with the Boundary-Scan (JTAG) mode gives you a versatile setup for easy debug and multiple configuration methods.
 - ◆ Master Serial mode provides a simple and robust configuration mode for production, and the Boundary-Scan (JTAG) mode provides in-system programming support for flexibility when configuring a chain in the prototyping stage.
- **Hardware Used:** Any combination of Xilinx Virtex/E or Spartan-II and companion XC18Vxx companion devices.
 - ◆ For Prototyping: Xilinx Cable (Parallel Cable IV, Parallel III or MultiLINX)

- ◆ For Production: Xilinx PROM and supporting Programmer / Software.
- **Software Used:** Xilinx FPGA programming or configuration.
 - ◆ For Prototyping: iMPACT Software to program Xilinx FPGA bitstreams (.bit files).
 - ◆ For Production: Third Party programmers or automatic test equipment to program PROM's to configure FPGA's.

Hardware Considerations

The hardware connections to implement the Master Serial/ Boundary-Scan (JTAG) Mode Combination are shown in the figure below for the Virtex or Spartan-II families.

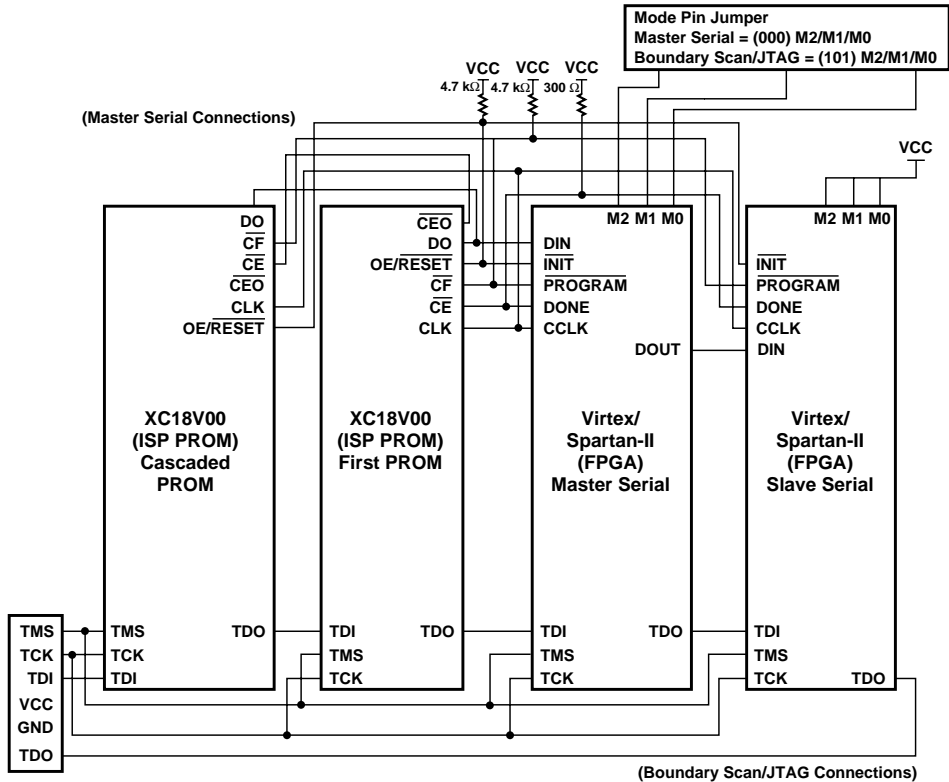

X9573

Figure 3-6 Virtex/Spartan-II Master Serial and Boundary-Scan (JTAG) Mode Connections

Virtex Spartan-II Master Serial and Boundary-Scan (JTAG) Mode Connections

Additional hardware considerations are listed below:

Refer to the appropriate family data sheets for voltage values required for each part.

For Spartan-II or Virtex mode pins, the following settings are required:

Master-Serial mode – M0=0, M1=0, M2=0

Boundary-Scan (JTAG) mode – M0=1, M1=0, M2=1

Boundary-Scan (JTAG) pins – For Virtex and Spartan-II, internal programmable 50-150 kW pullups are provided by default on the TMS, TCK, and TDI pins. TDO is floating.

Output buffer can source up to 24 mA and sink up to 48 mA.

The maximum Boundary-Scan (JTAG) clock, TCK, for the Virtex devices is 33 MHz and for Spartan-II is 2 MHz-5 MHz.

Software Implementation Considerations

Once the hardware setup has been established, you must create bitstreams to prepare for programming the devices. When using this configuration setup with the Virtex or Spartan-II devices, consider the following software implementation options when generating the bitstream.

Start-Up Clock – Generate the bitstream with the appropriate startup clock option to configure the part properly. The “Start-Up Clock” option by default is set to “CCLK” for Master Serial Mode. When generating a bitstream for Boundary-Scan (JTAG) Mode the option must be set to “JTAGCLK” in the pull-down menu of the GUI or using BitGen’s command line.

For configuring using Boundary-Scan (JTAG):

```
bitgen -g startupclk:jtagclk designName.ncd
```

For configuring via Master-Serial:

```
bitgen -g startupclk:cclk designName.ncd
```

If you use these two configuration modes in a setup, you must generate two bitstreams must be generated, one for the Boundary-Scan (JTAG) download and the other for the Master Serial download.

The Virtex or Spartan-II configuration options are the same for all of the Xilinx software packages. The default configuration option settings are recommended for this example, and some of the important options are described below:

“ConfigRate” is an implementation option which controls the speed of the CCLK in Master Serial Mode.

The configuration options include programmable pull-ups on the mode pins, PROGRAM, DONE, and CLK. Leave Boundary-Scan (JTAG) pins as a default.

For more detailed information or information on command line options, refer to the *Development Systems Reference Guide*.

Software Download Considerations

After creating the bitstream follow the recommended programming options for this setup as discussed below.

Prototyping

For prototyping with this setup, use the Xilinx iMPACT Configuration tool with a Xilinx cable to download the bitstream from the PC to the device. To achieve this, you must have access to the four Boundary-Scan (JTAG) pins of the Virtex, Spartan-II, or the XC18V00 device.

Production

In the production environment, systems must not be affected by power glitches or power down situations. Because the FPGA devices are volatile, a power outage erases the device contents. In order to ensure that the programmed data is not lost when the system is shut off, use a mode like Master Serial. The configuration data is permanently stored in the PROM in this example. If a power outage occurs, the data in the PROM reconfigures the FPGA when you regain power. Below are the steps needed to program a XC18V00 PROM.

- Use the PROM Formatter tab in the File Generation mode in iMPACT (GUI version) or PROMGen (command line version) to format the bitstream into a PROM file.
- Use iMPACT Boundary-Scan mode to program the PROM.

Configuration Checklist

Before designing a board with FPGAs/CPLDs, consider the following configuration issues.

Hardware:

- **Boundary-Scan (JTAG) Related:**
 - ◆ If there are multiple FPGAs/CPLDs/(ISP)PROMs in a configuration chain, consider adding jumpers to isolate the devices to allow each to be loaded separately for debugging.
 - ◆ Be sure to treat configuration or Boundary-Scan (JTAG) clocks like any other high-speed clock.
 - ◆ Consider adding extra spare pins to the design to bring signals out for later debugging.
 - ◆ Place buffers on TMS or TCK signals interleaved at various points on the Boundary-Scan (JTAG) circuitry to account for unknown device impedance.
 - ◆ Put the rest of the JTAG chain into HIGHZ mode by selecting the HIGHZ preference on iMPACT when having difficulty programming a particular part. This reduces any noise seen by the part.
 - ◆ If free running clocks are delivered into a Boundary-Scan (JTAG) device, you may have to disconnect or disable their entry into these devices during ISP or Boundary-Scan (JTAG) operations.
- **Cable Related:**
 - ◆ Do not attach extension cables to the target system side of the cable, because this can compromise configuration data integrity and cause checksum errors.
 - ◆ Attach cable configuration leads firmly to the target system.
 - ◆ The Parallel Cable used with PCs draws less power from the target board than the MultiLINX cable. This is because the MultiLINX cable utilizes an embedded microprocessor and has additional features like SelectMAP/USB support that the parallel cable does not have.
 - ◆ Design for the ability to configure using a cable, as well as your selected production configuration method, allowing for programming options and a method for debugging the part easily.
- **Board Related:**

- ◆ Include the ability to set the mode pins to different values using jumpers.
- ◆ Remember signal integrity issues, termination, edge rates, ground bounce, and trace layout.
- ◆ For designs over 60 MHz, Xilinx recommends that you simulate board level switching to ensure there are no reflection or ground bounce issues.
- ◆ Keep in mind simultaneous switching output issues.
- ◆ Ensure that the ground pins are not overloaded to prevent ground bounce on the outputs.
- ◆ Unused I/Os can be set as outputs tied to ground to add extra grounding to a device.
- ◆ If there is space, add LEDs to the DONE pins so that you can determine whether or not the FPGAs were configured.
- ◆ Put test points on the key configuration pins (DOUT, INIT, DONE, and PROGRAM) for debug and status information.
- ◆ Do not overload configuration signals. Check the Fan-out/Fan-in loading of the configuration signals.
- ◆ Use the Output Enable on your clock source so you can stop the system clocks during configuration to check for cross-talk and other noise issues.
- ◆ Be aware of switching noise that might cause erase time or programming time extension as the design progresses, especially for long chains.
- ◆ Make sure the Vcc is within the rated value for devices being used.
- ◆ Provide both 0.1 mF and 0.01mF capacitors at every Vcc point of the chip, and attach them directly to the nearest ground.
- **Software:**
 - ◆ Xilinx WEBPACK has the latest iMPACT software and can be used as a lab install.
 - ◆ Programmable pull-ups and pull-downs need I/O pins that are set in the software for configuration.

- ◆ Check if release of DONE comes after or before the DLL has locked on the system clock.
- ◆ Do not put regular design signals on configuration pins.
- ◆ The STARTUP block is not recommended for Virtex designs. If using this feature, be sure the internal signals do not conflict and lock up the part after configuration. The STARTUP reset polarity and the regular system reset need to be of the same polarity.
- ◆ Check for system noise by running the IDCODE looping instruction in iMPACT (**Operations** → **IDCODE Looping**). This displays the edit window. Specify the number of loops desired. The operation should complete this correctly otherwise, there might be system noise.

Using iMPACT to Configure Devices

This chapter shows you how to use iMPACT to program and verify devices, and supplies some troubleshooting tips for common issues. It focuses on the most commonly used features and methodologies in iMPACT. For more detailed information on specific menu items and options that are not covered here, use the context sensitive help inside the iMPACT program.

This chapter contains the following sections.

- “Configuration Mode General Information”
- “Connecting to a Cable”
- “Boundary-Scan Configuration Mode”
- “Available Boundary-Scan Operations”
- “Performing Boundary-Scan Operations”
- “Slave Serial Configuration Mode”
- “SelectMAP Configuration Mode”
- “Desktop Configuration Mode”

Configuration Mode General Information

Configuration is the process of loading design-specific information into one or more FPGA, PROM, or CPLD devices to define the functional operations of the logical blocks, their interconnectors, and the chip I/O. When configuring devices in this mode of iMPACT, you must have one of three cables; Parallel Cable III, Parallel Cable IV, or a MultiLINX cable.

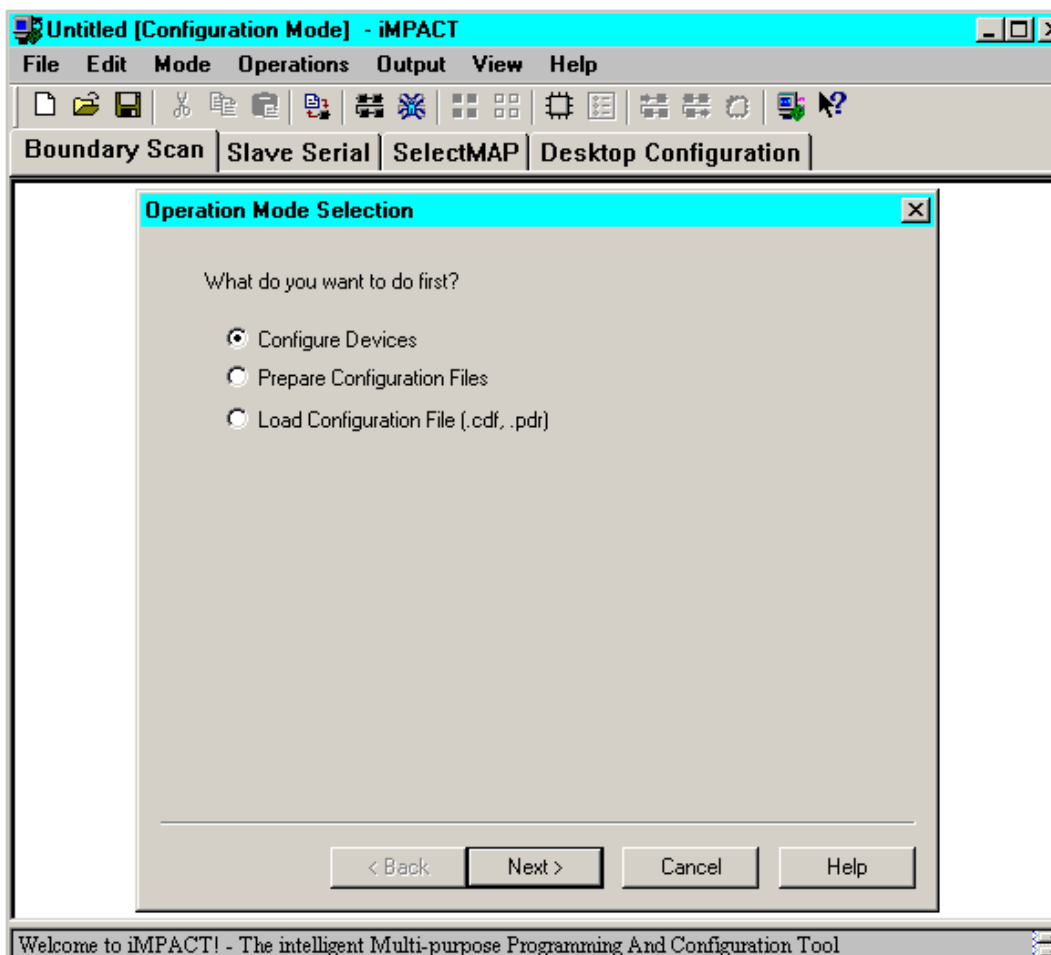

Figure 4-1 Initial Window When Opening iMPACT stand-alone

In the initial window of iMPACT, the wizard prompts you to select an operation mode. To configure devices, select the Configure Devices radio button, then select Next. The Configure Devices wizard appears.

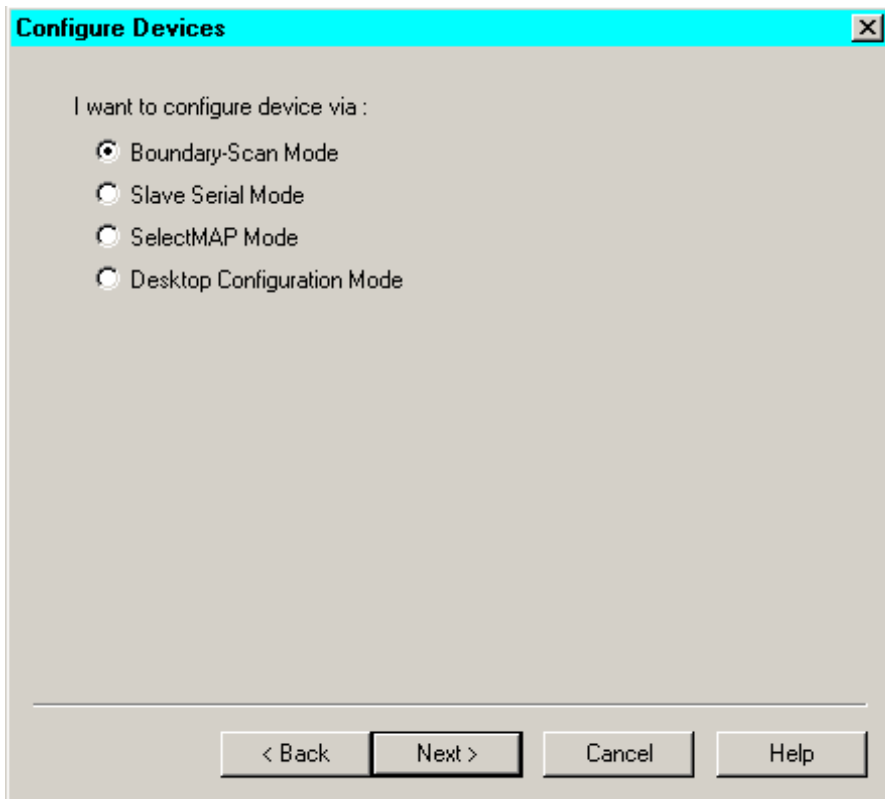

Figure 4-2 Configure Devices Wizard

Connecting to a Cable

A connection to a cable must be established before operations can be performed on a device. If a connection has not been established, attempting to perform any cable operation, such as Program, causes iMPACT to attempt to auto detect the cable. An alternate method is to right-click on a blank portion of the iMPACT window and select either **Cable Auto Connect** or **Cable Setup**.

Cable Auto Connect forces the software to search every port for a connection. Cable Setup enables you to select the cable and the port connection.

```
GUI --- Auto connect to cable...
AutoDetecting cable. Please wait.
CB_PROGRESS_START - Starting Operation.
Connecting to cable (USB Port).
Cable connection failed.
Connecting to cable (Parallel Port - LPT1).
Checking cable driver.
Cable device driver is not installed.
Installing WinDriver...
Failed.
```

Figure 4-3 Failed Attempt to Establish Cable Connection

If a cable is connected to the machine and the cable autodetection fails, use the following steps to debug:

1. Verify that the Vcc and GND pins of the cable are connected to Vcc and GND on the board and make sure that the power supply for the board is turned on.
2. If a connection was previously established with another cable or if the configuration mode has changed, terminate the previous connection by selecting **Output** → **Cable Disconnect** from the menu at the top of the iMPACT window.
3. Try performing a cable reset by selecting **Output** → **Cable Reset**.
4. Check the connection to the port on the computer and try another port if possible.
5. Shut down the software and reopen it.
6. Verify that the drivers for the cables were installed. Open the `fileset.txt` file that is located in the directory where the software was installed. The following lines should be in this file:

```
<Date of install> <Time> <Year>:: summary=MultiLINX Cable
Driver
```

```
<Date of install> <Time> <Year>:: summary=Parallel Cable III Driver
```

If these lines are not present, the drivers were not installed. They are installed by reinstalling the software or by installing the Webpack Programmer.

Boundary-Scan Configuration Mode

Boundary-Scan Configuration mode enables you to perform Boundary-Scan Operations on any chain of JTAG compliant devices. The chain can consist of both Xilinx and non-Xilinx devices, but only the BYPASS and HIGHZ operations are available for a non-Xilinx devices.

To perform operations, the cable must be connected and the JTAG pins, TDI, TCK, TMS, and TDO need to be connected from the cable to the board. The Boundary-Scan chain that is created in the software must match the chain on the board. If the chain consists of eight devices, but only one of them is going to be configured, all eight devices must be added to the chain in the iMPACT window.

Automatically Creating the Chain

To automatically create the chain, right-click on an empty space in the iMPACT window and select Initialize Chain. iMPACT passes data through the devices and automatically identifies the size and composition of the Boundary-Scan chain.

Any supported Xilinx device is recognized and labeled and any other device is labeled as unknown. iMPACT then highlights each device in the chain and prompts you for a configuration file.

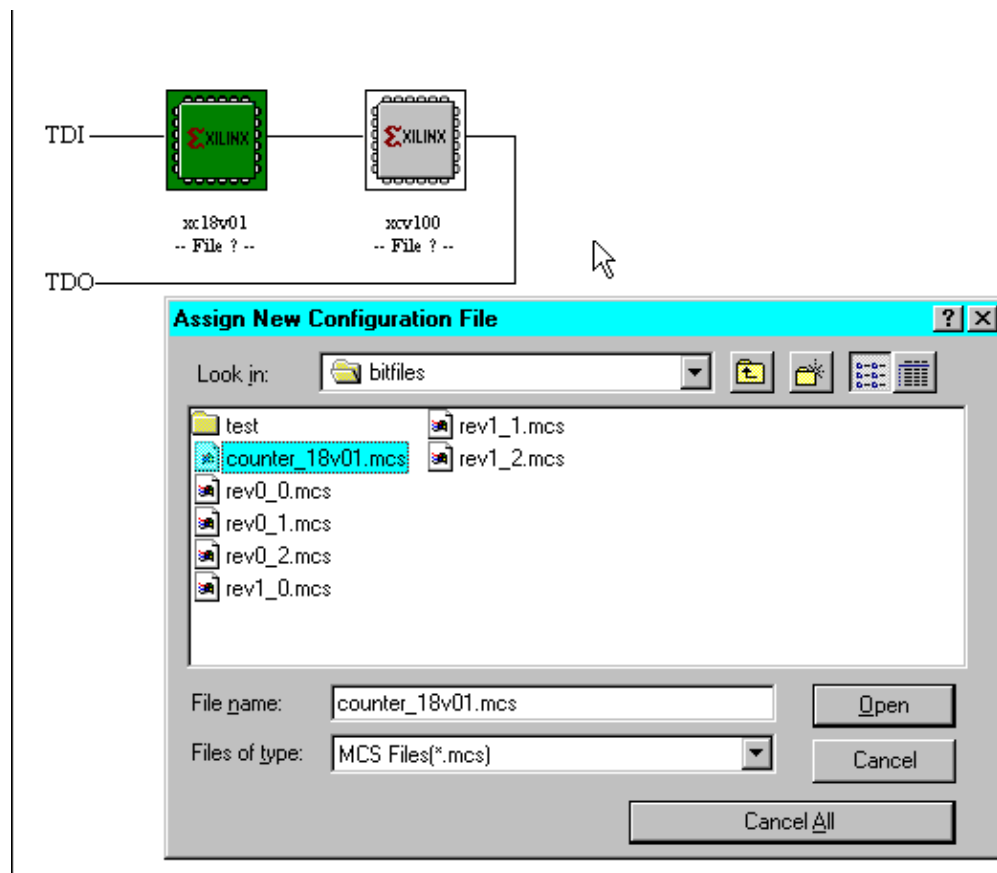

Figure 4-4 Assign New Configuration File Dialog Box

Manually Creating the Chain

The chain is manually created or modified as well. To perform this operation, right-click on an empty space in the iMPACT window and select **Add Xilinx Device** or **Add Non-Xilinx device**. This enables you to add devices one at a time. The device is added where the large cursor is positioned. To add a device between existing devices, click on the line between them and add the new device.

Manually adding devices is useful when creating a chain that is used to generate an SVF or STAPL file. However, the Initialize Chain command should be used whenever possible. Initializing the chain

verifies that the chain is set up correctly and that iMPACT can correctly identify all of the devices.

Assigning Configuration Files

There are several types of configuration files. A Bitstream file (*.bit) is used to configure an FPGA. A JEDEC file (*.jed) is used to configure a CPLD. A PROM file (*.mcs or .exo,) is used to configure a PROM and to program FPGAs in Slave Serial mode. A System ACE MPM/SC (.mpm) file is used to program it's associated Flash. A IEEE 1532 JTAG (.isc) file can be used to program IEEE compliant Xilinx devices. A Raw BIT File (*.rbit) is an ASCII version of the BIT file. The only difference is that the header information in a BIT File is removed from the Raw BIT File.

After initializing a chain or adding a device, iMPACT prompts you for a configuration file (see Figure 4-4). This is the file that is used to program the device. If a configuration file is not available, a Boundary-Scan Description File (BSDL or BSD) file can be applied instead. The BSDL file provides iMPACT with necessary Boundary-Scan information that enables a subset of the Boundary-Scan operations to be available for that device.

To select a BSDL file, change the file type to *.bsd in the Assign New Configuration File window and browse to the BSDL file (see Figure 4-5). BSDL files for Xilinx devices are located in the \$Xilinx\

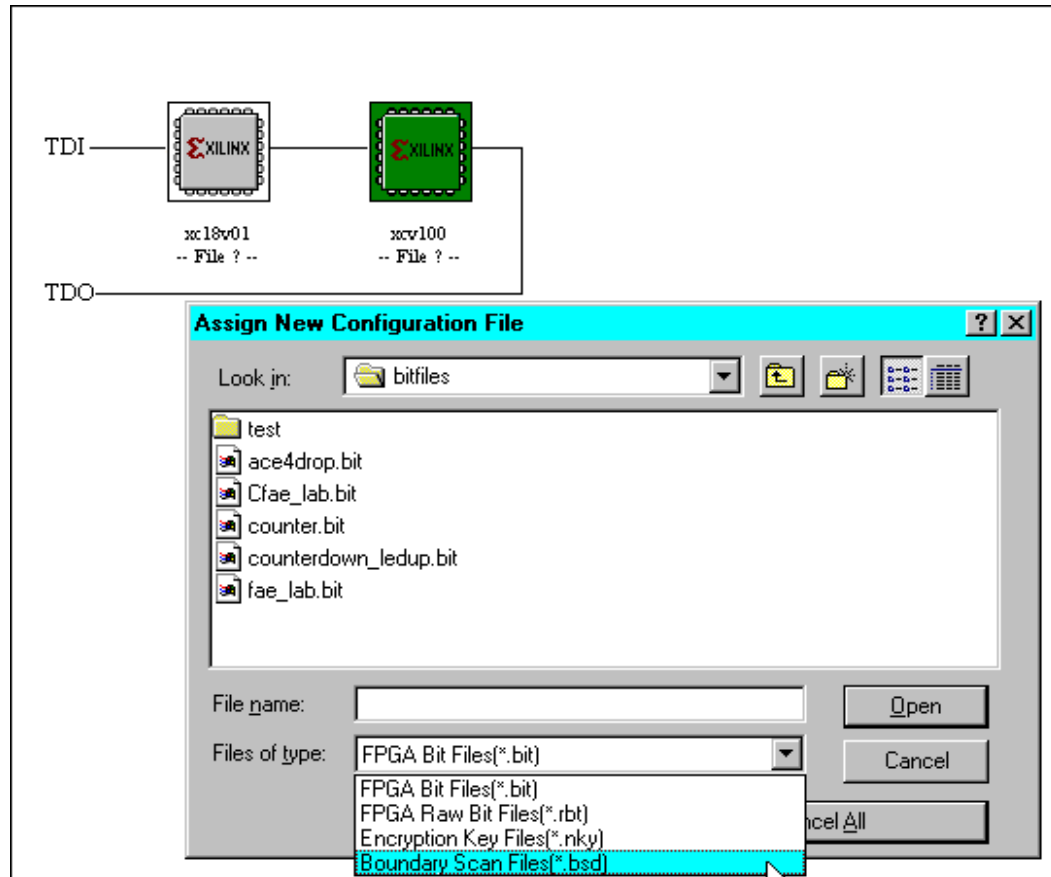

Figure 4-5 Selecting a BSDL File

For Xilinx devices, you do not have to associate a BSDL, JEDEC, or BIT file with devices that you only wish to place in bypass mode. Press Cancel for that device in the Assign New Configuration File dialog box. When any chain operation is attempted, iMPACT automatically searches the Xilinx directories for the correct BSDL file and places the device in bypass mode.

For non-Xilinx devices, a BSDL must be applied. The BSDL file is typically obtained from the vendor of the device. If a BSDL file cannot be obtained, iMPACT can create a generic BSDL file. When a non-

Xilinx device is added, iMPACT asks you if a BSDL or BIT file exists for the device (see Figure 4-6).

If yes, you can browse to the file. If no, iMPACT asks you for the device name and the Instruction Register Length (see Figure 4-7). This minimal amount of information enables iMPACT to create a generic BSDL file and enables the device to be put in BYPASS or HIGHZ. Check with the vendor of the device to obtain the Instruction Register Length.

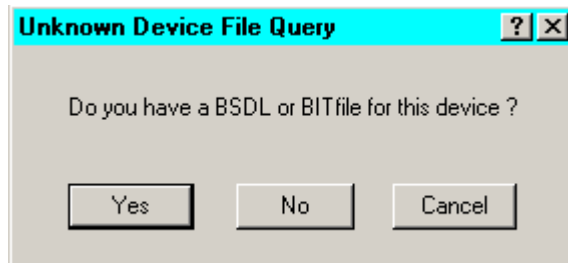

Figure 4-6 Unknown Device Query

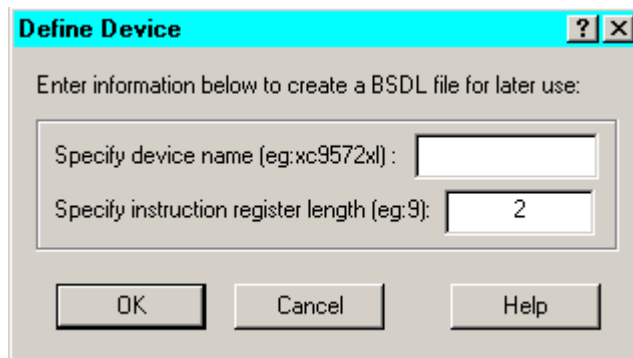

Figure 4-7 Defining an Unknown Device

Saving the Chain Description

Once the chain has been fully described, it can be saved for later use. This prevents you from having to redefine the chain each time the iMPACT software is started. To do this, select **File** → **Save** or **Save As**. This creates a Chain Description File (*.CDF).

To restore the chain when reopening iMPACT, select **File** → **Open** and browse to the CDF file. The CDF file is also selected in the Process Properties window in ISE. This restores the chain when opening iMPACT from the Project Navigator.

Edit Preferences

To edit the preferences for the Boundary-Scan Configuration, select **Edit** → **Preferences**. This opens the window shown in Figure 4-8. Click on help for a description of the Preferences.

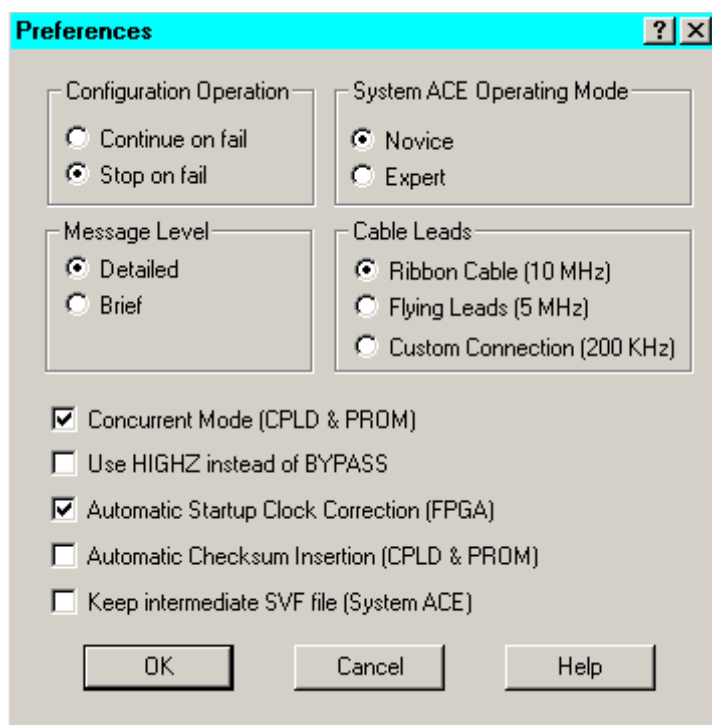

Figure 4-8 Edit Preferences

Available Boundary-Scan Operations

The available Boundary-Scan Operations vary based on the device and the configuration file that was applied to the device. To see a list of the available options, right-click on any device in the chain. This brings up a window with all of the available options. Figure 4-9 shows the available options for a XC9500XL device that has a JEDEC file applied to it.

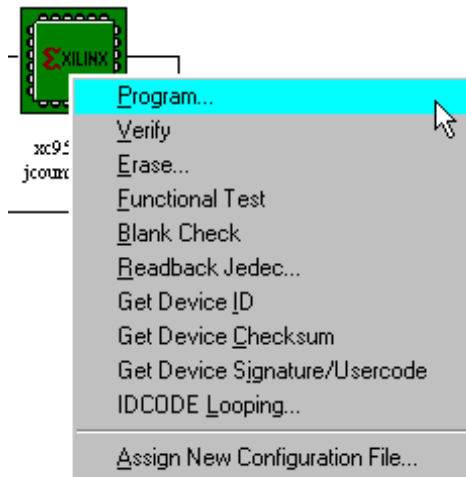

Figure 4-9 Available Boundary-Scan Operations for an XC9572XL device

When a Virtex device is selected, a different set of options are available (see Figure 4-10).

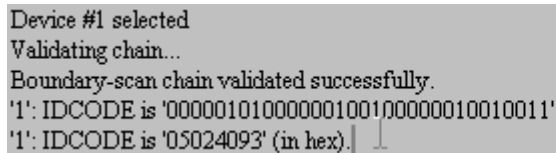

Figure 4-10 Available Boundary-Scan Operations for a Virtex device

Performing Boundary-Scan Operations

Boundary-Scan operations are performed on one device at a time. When you select a device and perform an operation on that device, all other devices in the chain are automatically placed in BYPASS (or HIGHZ - see Figure 4-8).

To perform an operation, right click on a device and then left click on one of the selections. For instance, when the Virtex Device is right-clicked, the window in Figure 4-10 appears. Then left click on **Get Device ID**. The software gets the IDCODE for this Virtex Device. The result is displayed in the Log Window (see Figure 4-11).



```
Device #1 selected
Validating chain...
Boundary-scan chain validated successfully.
'1': IDCODE is '00000101000000100100000010010011'
'1': IDCODE is '05024093' (in hex).
```

Figure 4-11 Log Window showing result of Get Device ID

For another example, if the user right clicks on the XC9572XL and then left clicks on Program (see Figure 4-9), the Program Options Window appears (see Figure 4-12). You then select the desired options and click OK to begin programming. The Program options vary based on the device.

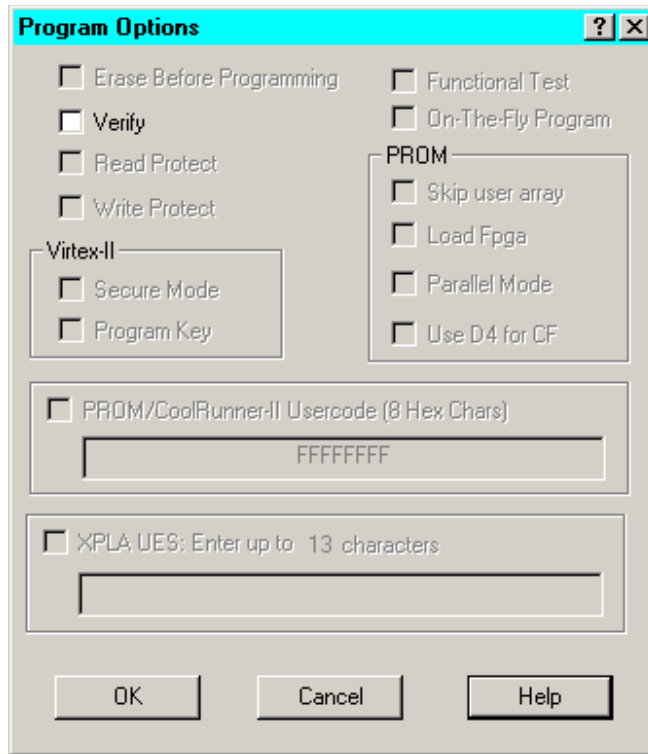

Figure 4-12 Program Options dialog box

After clicking on OK, the Program operation begins and an operation status window appears (see Figure 4-13). At the same time, the log window reports all of the operations being performed.



Figure 4-13 Operation Status

When the Program operation completes, a large blue message appears showing that Programming Succeeded (See Figure 4-14).

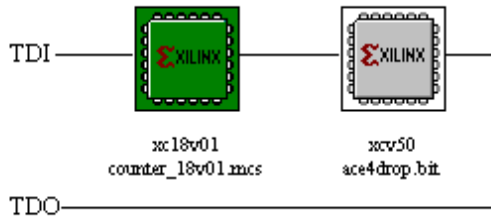

Figure 4-14 Programming Succeeded

The log window shows that the programming completed successfully and that all of the operations were performed (see Figure 4-15).

```
Device #1 selected
Validating chain...
Boundary-scan chain validated successfully.
'1': Putting device in ISP mode...
done.
'1': Erasing device...
done.
'1': Erasure completed successfully.
'1': Putting device in ISP mode...
done.
'1': Programming device...
done.
'1': Setting user-programmable bits...
done.
'1': Programming completed successfully.
=>
```

Figure 4-15 Log window showing successful configuration of the CPLD

Operations can continue to be performed in this manner. Select a device and then select the operation. Wait for the previous operation to complete and then perform the next operation.

Slave Serial Configuration Mode

Slave Serial Configuration mode enables you to program a single Xilinx device or a serial chain of Xilinx devices.

To use the Slave Serial Configuration Mode, enter via the wizard, or click on the Slave Serial Tab at the top of the iMPACT window and establish a cable connection by right-clicking on a blank section of the iMPACT window and selecting **Cable Auto Connect**.

Adding a Device

To add a device, right click on the iMPACT window and select **Add Xilinx Device** (see Figure 4-16).

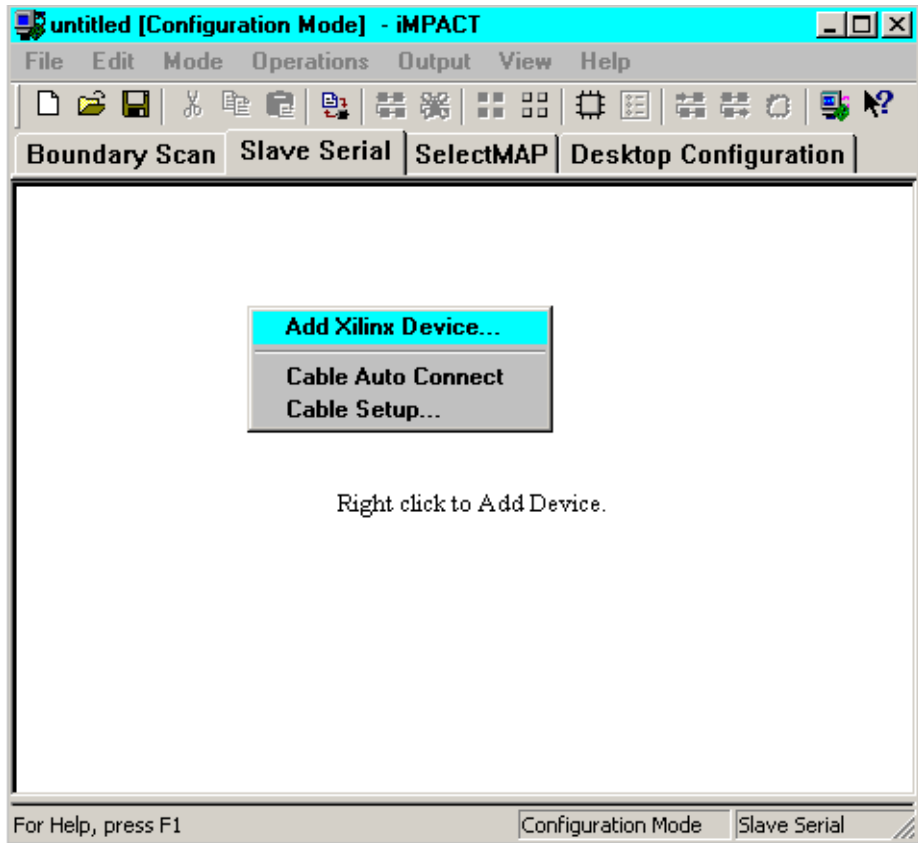

Figure 4-16 Adding a Xilinx Device in Slave Serial Mode

After clicking on **Add Xilinx Device**, a window appears that enables you to browse to the desired file (see Figure 4-17).

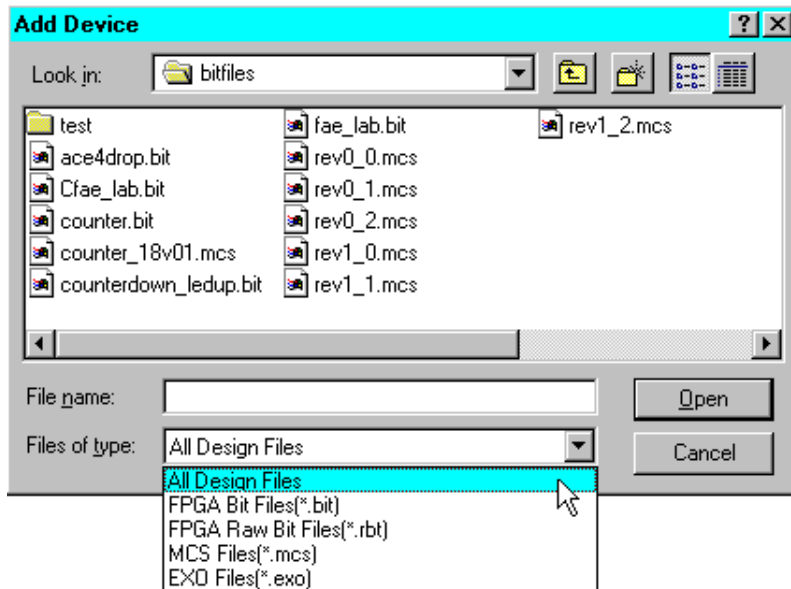

Figure 4-17 Add Device File Types for Slave Serial

Notice in Figure 4-17 that there are a number of different file types to select from. An explanation of each type is below:

FPGA BIT File (*.bit). Standard BITfile created by BitGen. A BIT file is used to program a single FPGA.

FPGA Raw BIT Files (*.rbt). A Raw BIT File is an ASCII version of the BIT file. The only difference is that the header information in a BIT File is removed from the Raw BIT File. This is also created by BitGen and is used to program a single FPGA.

MCS and EXO Files (*.mcs, *.exo). These are PROM files. To program a serial chain of Xilinx devices, a PROM file is used to concatenate all of the BIT files. This device represents a single device when a BIT or RBT file is used, and could represent a chain of devices when a PROM file is used. The PROM files are created in the PROM Formatter tab in the File Generation mode of iMPACT.

Only one file can be loaded for Slave Serial Configuration Mode so the PROM file must be used for programming a serial chain of devices. Once the desired file is selected, a window similar to Figure 4-18 appears.

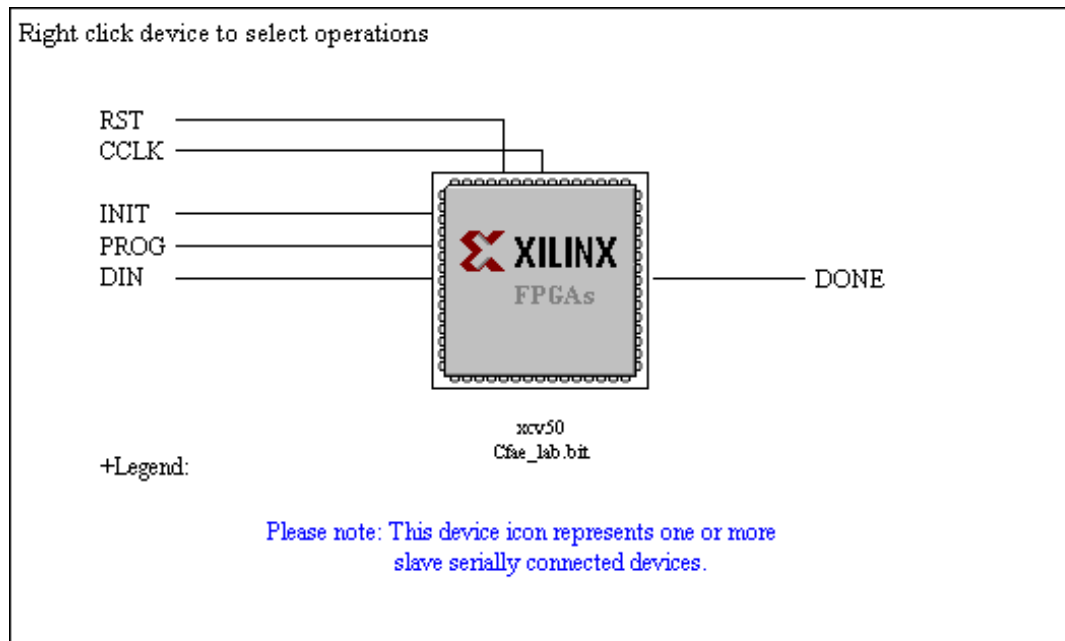
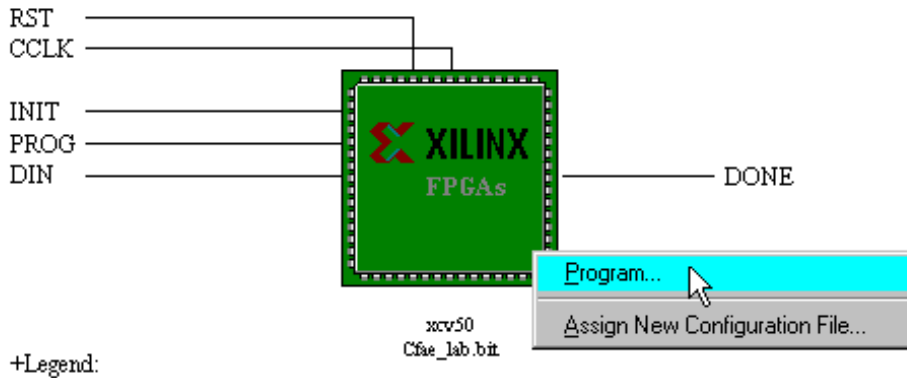

Figure 4-18 Device Loaded with a Single BIT File

Even if a chain of devices is being programmed, only the single device shown in Figure 4-18 appears. This device represents a single device, when a BIT or RBT file is used and represents a chain of devices when a PROM file is used.

Programming the Device

To program a device, right click on the device and then select **Program** (see Figure 4-19).



Please note: This device icon represents one or more slave serially connected devices.

Figure 4-19 Selecting the Program Option

When Program is selected, iMPACT begins programming the device or chain of devices. When it completes, a message shows that programming succeeded.

Troubleshooting Slave Serial Configuration

If configuration fails, the window in Figure 4-20 appears.

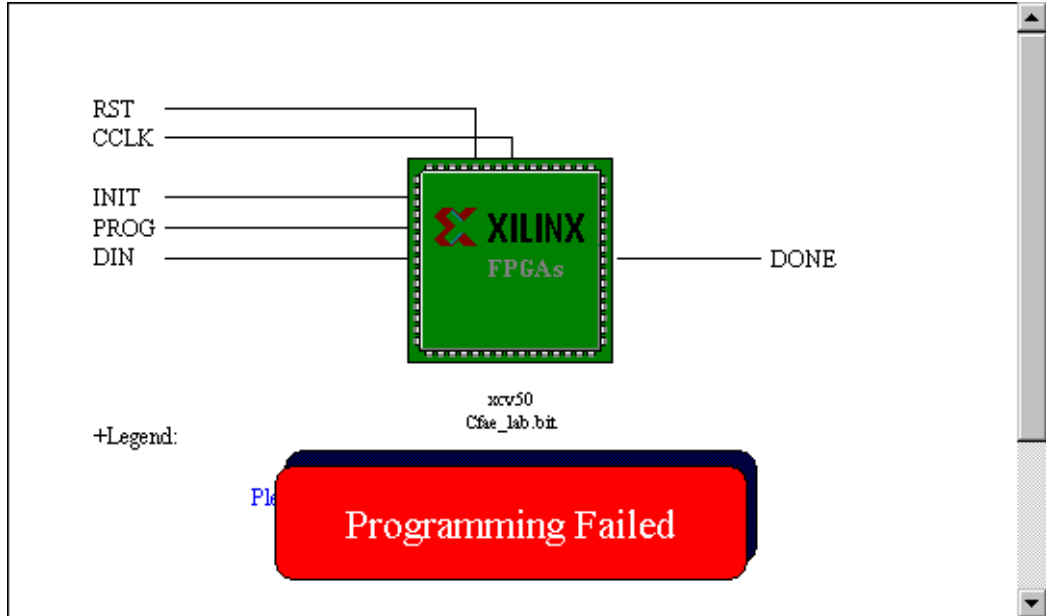

Figure 4-20 Programming Failed

There are two main error messages that you may encounter. The first is:

1. DONE pin did not go low. Please check cable connection.
Programming terminated due to error.

The first step in programming through slave serial is that PROG is pulsed low, which erases the device and forces DONE to go low. If the above error message appears, it is likely that the PROG or DONE pin of the cable is not properly connected to the device.

The second common error message is:

2. Done pin did not go high. Programming terminated due to error.

The above error message can occur for many reasons. Below are some of the common causes:

- The Mode pins on the device are not set to Slave Serial
- DIN, INIT, or CCLK are not connected.
- Noise is corrupting CCLK or DIN signals.

- The hardware is not set up properly.
- The wrong configuration file was used or the PROM file does not have the BIT files concatenated in the correct order.

SelectMAP Configuration Mode

With iMPACT, SelectMAP Configuration mode enables you to program up to three Xilinx devices. The devices are programmed one at a time and are selected by the assertion of the correct CS pin. To use the SelectMAP Configuration Mode, click on the SelectMAP tab at the top of the iMPACT window and establish a cable connection. Only the MultiLINX cable can be used for SelectMAP Configuration.

Adding a Device

To add a device, right click on the iMPACT window and select **Add Xilinx Device** (see Figure 4-21).

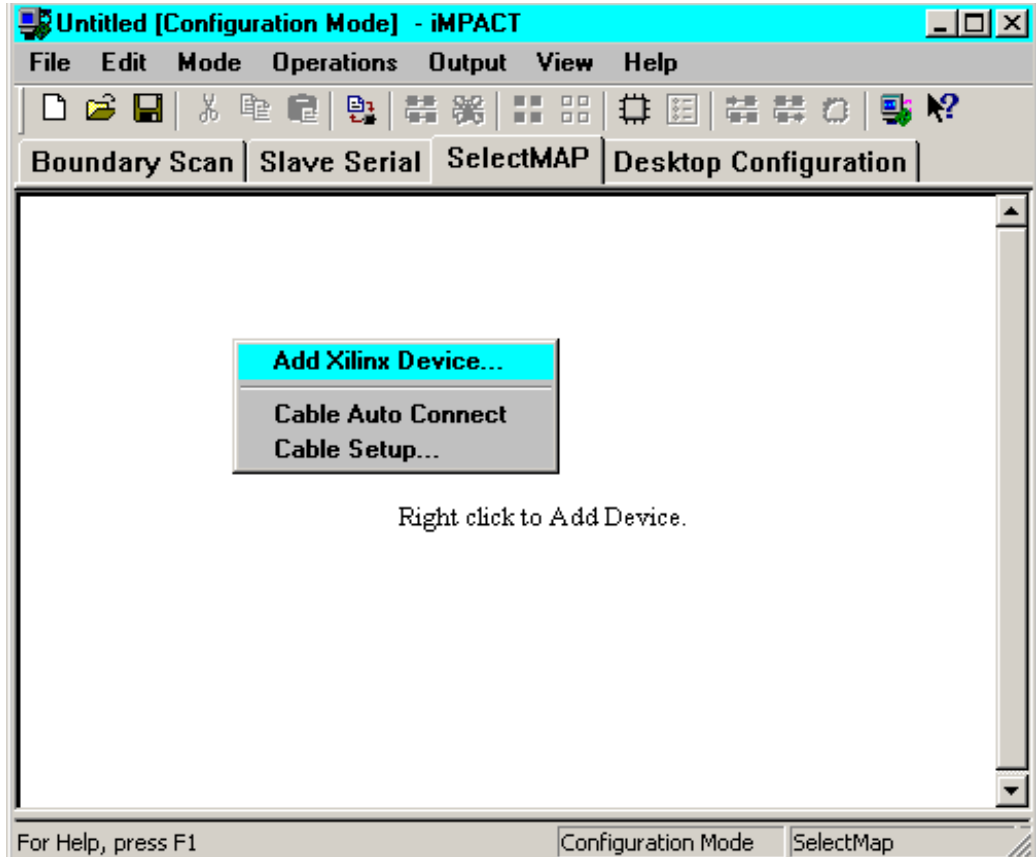

Figure 4-21 Adding a Device for SelectMAP Configuration

After clicking on **Add xilinx Device**, a window appears that enables you to browse to the configuration file(see Figure 4-22).

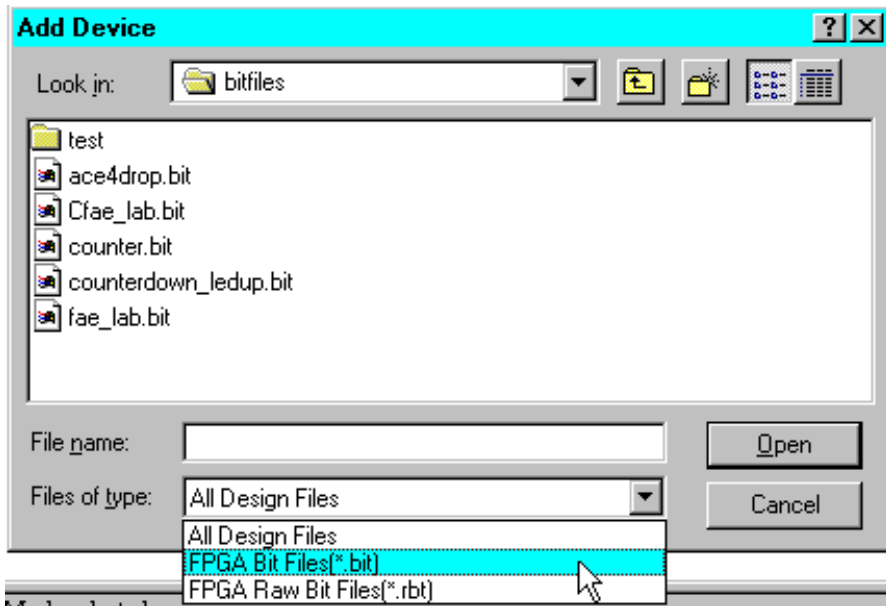

Figure 4-22 Configuration File Types for SelectMAP Mode

Notice in Figure 4-22 that only two file types can be used, FPGA BIT Files and FPGA Raw BIT Files. For a description of these files, see the Add Device Section for Slave Serial Configuration.

Once a BIT or RBT file is selected the device appears in the iMPACT window. Up to three devices can be added. Figure 4-23 shows an example where two devices have been added. Notice that each one has a different Chip Select (CS) pin. These correspond to the CS pin on the MultiLINX Cable. Make sure that the correct CS pin is connected to the correct device. The CS pins are swapped by dragging and dropping the pins in the window.

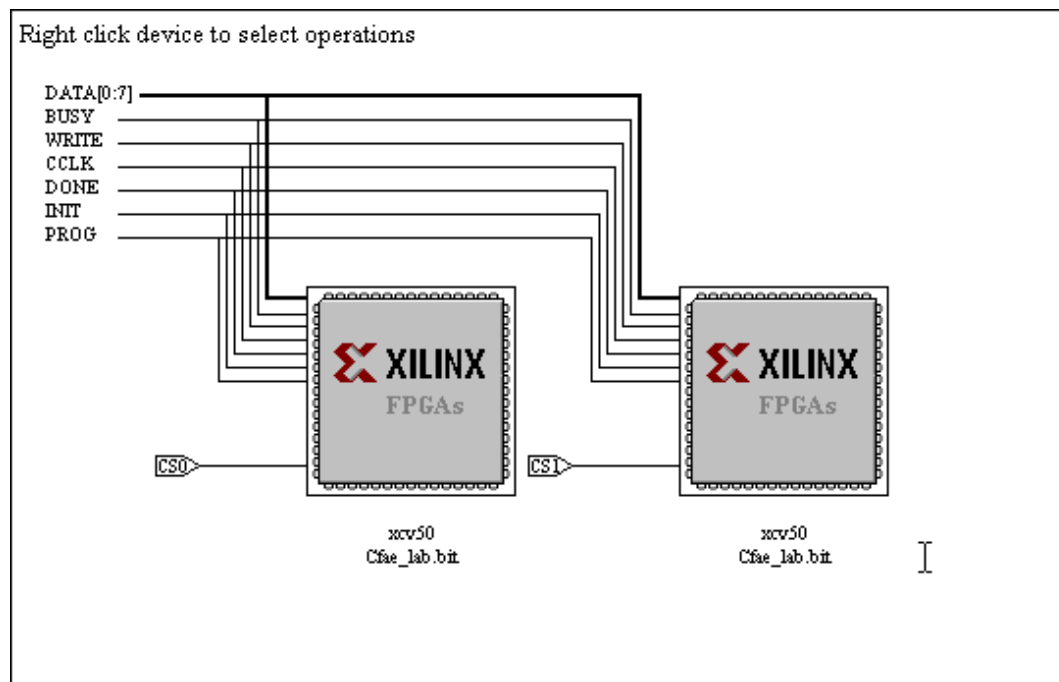

Figure 4-23 Two Devices Added for SelectMAP Configuration

Programming and Verifying a Device

To program or verify a device, right click on the device and then select **Program** or **Verify** (see Figure 4-24). The MultiLINX cable asserts the correct CS pin and then performs that operation on that device.

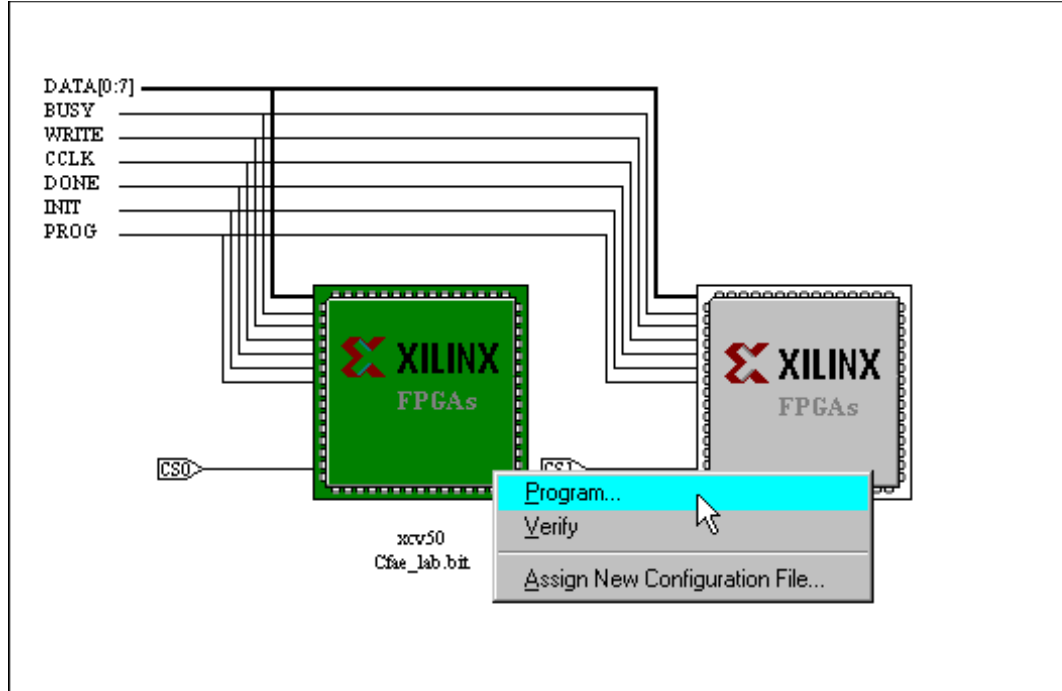

Figure 4-24 Selecting Program or Verify in SelectMAP Mode

When **Program** or **Verify** is selected, iMPACT performs the operation and a status message indicates the operation completed successfully.

Troubleshooting SelectMAP Programming and Verify

If **Program** or **Verify** fails, a red status message indicates the operation failed. Figure 4-25 shows a failed Program Operation.

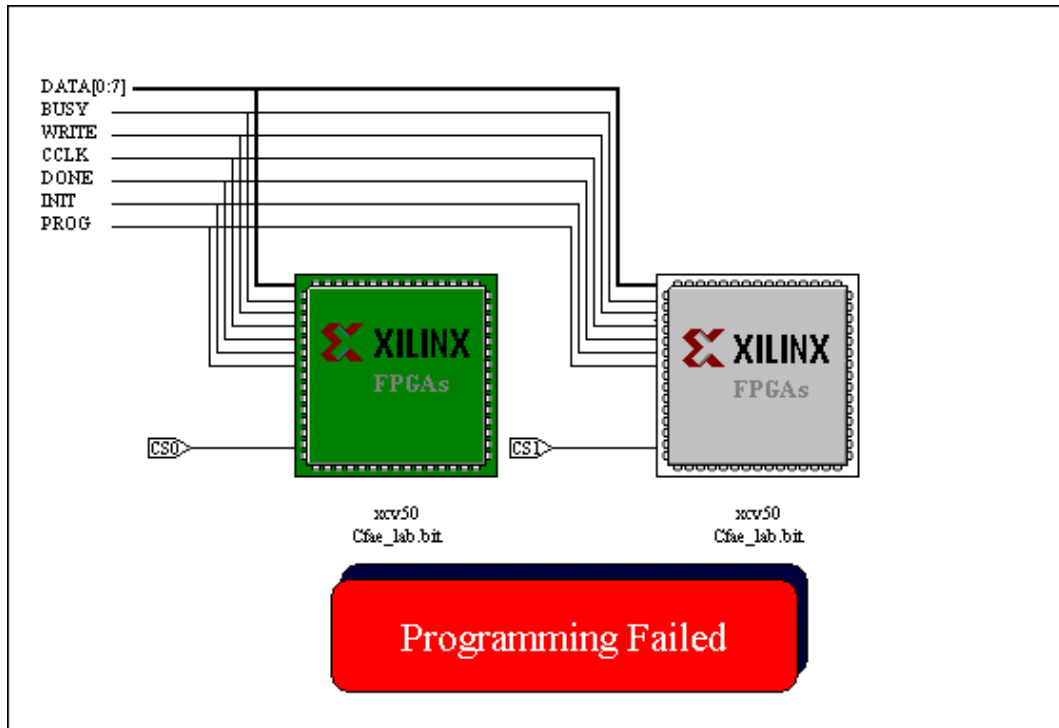

Figure 4-25 SelectMAP Programming Failed

When Programming fails, the error message reads:

Done pin did not go high.

Programming terminated due to error.

Programming failed.

The above error message can occur for many reasons. Below are some of the common causes:

- The Mode pins on the device are not set to SelectMAP Mode.
- One or more of the SelectMAP signals are not connected properly.
- The wrong CS pin is connected to the device.
- Noise is corrupting CCLK or the DATA lines.

- The hardware is not set up properly.
- The wrong configuration file was applied to the device.

When Verify fails, the error message reads:

ERROR:Bitstream:98 - There are ## differences.

ERROR:iMPACT:395 - The number of difference is ##

Verification failed.

The above error message can be caused by any of the conditions listed above for a failed Program operation. In addition, the problem might be caused because the BIT File was generated incorrectly. If security is set to Level1 or Level2 or if Persist is set to No, verify fails. Check the BitGen options and make sure that Security is set to None and Persist is set to YES.

Desktop Configuration Mode

The Desktop Configuration mode is used to configure single, non-volatile, socket-based devices using the Xilinx MultiPRO Desktop Configuration Cable. The MultiPRO supports the CoolRunner II CPLD family, the XC18V00 Flash PROM family, and all System ACE-MPM modules.

Automatically Identifying the Device

To automatically identify the device, select **File → Identify Device**. iMPACT passes data through the device and automatically identifies the type of device connected. Any supported Xilinx device is recognized and labeled. iMPACT then highlights the device and prompts you for a configuration file.

Manually Identifying the Device

The chain can be manually created or modified as well. To perform this operation, right-click on an empty space in the iMPACT window and select **Add Xilinx Device**. The device is added where the large cursor is positioned.

Assigning a Configuration File

After identifying the device, iMPACT prompts you for a configuration file. This is the file that you use to program the device.

If you want to assign a new file to the device, the device must first be selected. You can then select **Edit**, or right-click and select **Assign New Configuration File**.

Setting Options

Note In contrast to the other configuration modes in iMPACT, Desktop Programmer mode requires that you set options before performing device operations. This enables you to set options once, then operate on several devices using those settings. If you do not set options first, default settings are applied.

To set the program options, select the device, then in the **Options** menu, select **Program Option**. The Program Options dialog box appears (Figure 4-26).

The same steps also apply for **Erase** and **Readback** operations.

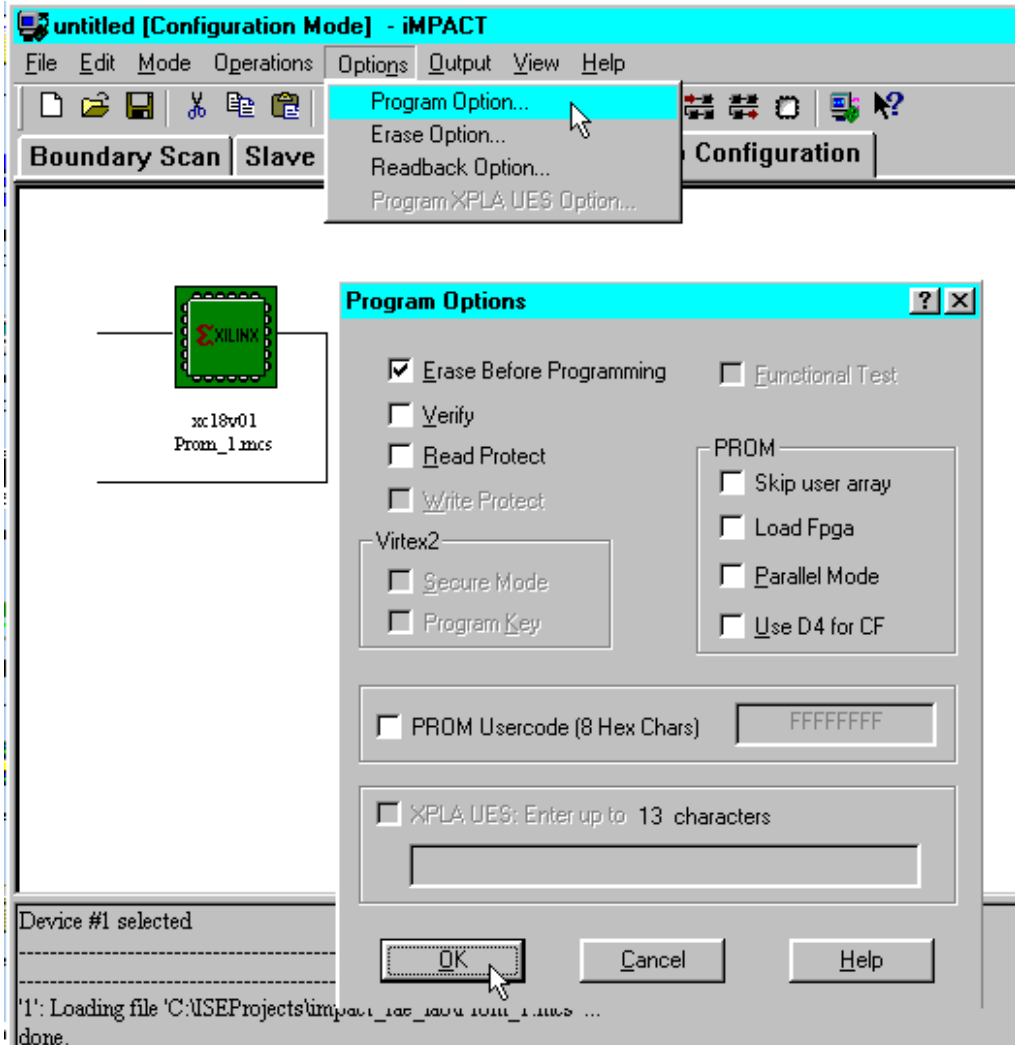

Figure 4-26 Program Options Dialog Box

Performing Device Operations

For the programming of devices in Desktop Programming mode, there are three commonly used buttons located on the iMPACT toolbar. From left to right, they are; Program, Verify, and Erase (See Figure 4-27).



Figure 4-27 Desktop Programmer Toolbar Buttons

To program a device, the device must first be selected. Once selected, you then click the **Program** toolbar button. If you right-click, you receive more operation choices.

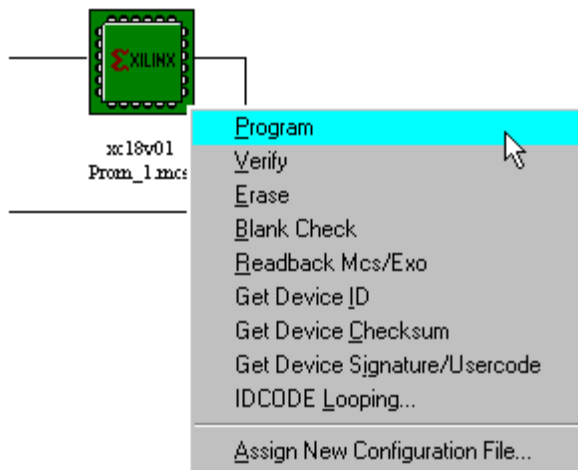

Figure 4-28 Right-Click Programming Options

Using iMPACT to Generate Files

iMPACT supports the generation of secondary configuration files based on bitstreams or JEDEC files in five formats: System ACE CF (.ace) and MPM (.mpm), PROM Files (.tek, .exo, .mcs, and .hex), SVF and STAPL files. System ACE and PROM files are output files which can be used to program one or more devices. SVF and STAPL files contain both programming instructions and configuration data. They are used by ATE machines and embedded controllers to perform Boundary-Scan operations.

This chapter contains the following sections.

- [“General File Mode Instructions”](#)
- [“Creating System ACE Programming Files”](#)
- [“Creating PROM Formatter Programming Files”](#)
- [“Creating an SVF or STAPL File”](#)

General File Mode Instructions

When iMPACT is first launched, a wizard appears that enables you to start the file generation process, as shown in Figure 5-1.

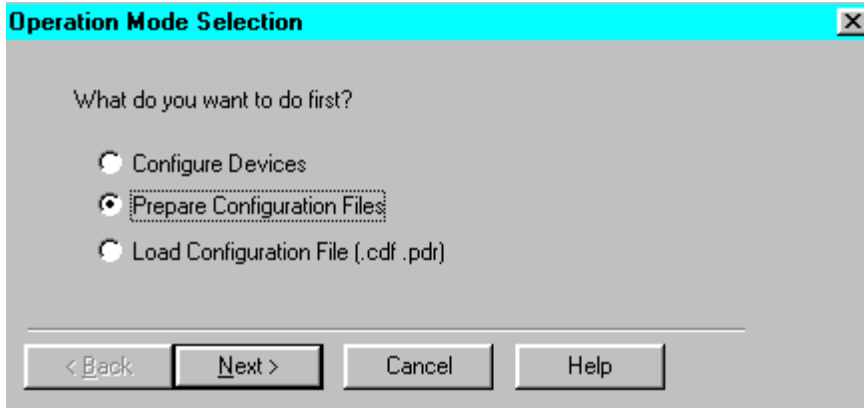

Figure 5-1 Operation Mode Selection Wizard

To generate a System ACE or PROM file, you must use the wizard to set required properties. To access the wizard from anywhere inside iMPACT, select **Edit** → **Launch Wizard** as shown in Figure 5-2.

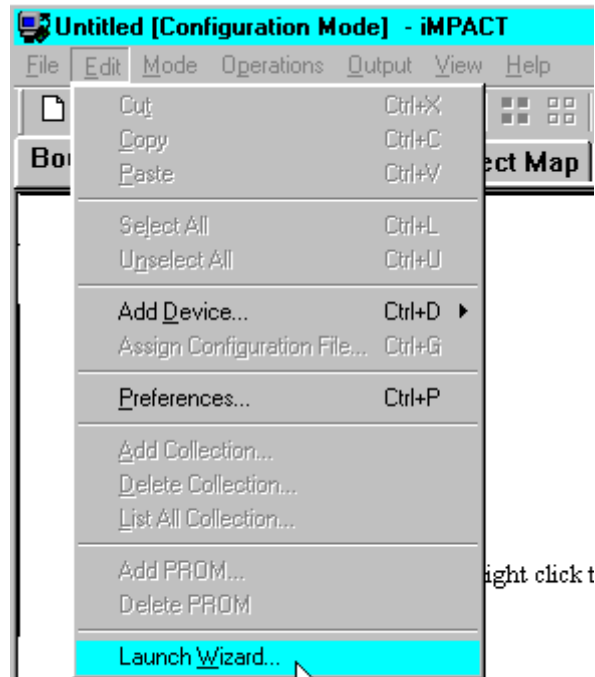

Figure 5-2 Launching the Wizard from the Edit Menu

A dialog appears telling you that launching the wizard "cleans up" (erases) all current contents from all modes. If you wish to save your current work, click No, then select **F**ile → **S**ave to save a .cdf file. Then relaunch the wizard. If you wish to continue, click Yes.

Creating System ACE Programming Files

There are two types of System ACE products, System ACE CF and System ACE MPM. Although similar in some ways, each product type uses a different configuration methodology and therefore each requires a different type of file. System ACE CF uses Boundary-Scan protocol to configure devices connected to the System ACE CF controller, while System ACE MPM uses either Slave Serial or SelectMAP configuration protocols.

The following sections explain the settings on the wizard screens for the individual System ACE types. After setting the properties, you are prompted to add devices to the configuration chain or chains. As

the final step in the wizard, you are asked if you wish to generate the System ACE file. If you click "No", you can generate the file later by using the Operations Menu.

System ACE CF Settings

The following are System ACE CF Wizard Selections.

Size

This enables you to specify the size of the compact flash you use in conjunction with the System ACE Controller. This enables iMPACT to automatically confirm that the System ACE files fit in your selected Compact Flash device. If your device is larger than 256 Megabits, or if you wish to disable this check, select Generic.

Reserve Space

This enables you to set aside space in the Compact Flash for other information, such as microprocessor code, general purpose ROM, etc. This value is subtracted from the CF size, and the calculation for System ACE files is based upon this reduced size.

System ACE CF Collection Name

All of the configuration files related to the eight different revisions in your System ACE design are referred to as a collection. This selection prompts you for the first collection name. You are able to create other collections later in the flow. When creating the System ACE file, you are prompted for which collection to make active. The active collection is the one used to configure the devices on your board.

Location

This is the directory path where you want your collection(s) to be saved on your local or network disk.

Configuration Address

These are also referred to as "revisions" and are accessed at run-time by using the physical address pins of the CF controller. You have up to eight of these "revisions" per collection. Check the box next to the configuration address you wish to use.

Design Name

This is the name of the "revision." Default is "rev<n>" where n corresponds to the configuration address number.

System ACE MPM Settings

Size (16,32,64, Generic)

Enables you to specify the size of the MPM device you use. This enables iMPACT to automatically confirm the System ACE files fit in your selected MPM device.

Note The Generic file generation can be used when the desired Flash size is unknown.

System ACE MPM Name

This is the name of your System ACE MPM/SC formatted file.

Location

This is the directory path where you want your MPM file to be saved on your local or network disk.

Target in: Slave Serial Mode or SelectMAP Mode

Enables you to specify how devices are connected on your board. You have the choice of either connecting the FPGAs via SelectMAP parallel bus, or you can have up to 8 separate Slave Serial daisy chains. You can only select one mode per single MPM/SC device, as each configuration method is mutually exclusive of the other.

Slave Serial Mode > Number Of Chains

Clicking on a checkbox next to a data pin enables System ACE MPM/SC to download to a Slave Serial chain, connected to that data pin. You may have up to 8 independent daisy chains. You do not have to use sequential data pins. For example, you can have a chain hooked up to ConfigData0, and then another hooked up to ConfigData5, with none of the others used. Simply check the box next to the pin you are using.

SelectMAP Mode > Specify CS Pin to be used in this design

Clicking on a checkbox next to a Chip Select pin enables that pin as a chip select to a device in SelectMAP mode. You can have up to four FPGA devices connected to the System ACE MPM/SC device. You do not have to use sequential Chip Select pins. You can have one device hooked to CS0, and another connected to CS3. Simply check the box next to the pin you are using.

Configuration Address

This selection applies to both Slave Serial and SelectMAP MPM/SC configurations. These addresses are also referred to as "revisions" and are accessed at run-time by using the physical address pins of the MPM/SC device. You can have up to eight of these "revisions" per collection. Check the box next to the configuration address that you wish to use.

File Generation > Compress File

MPM/SC devices offer compression/decompression of bitstreams which enables you to utilize the flash memory space more efficiently, effectively increasing the bitstream capacity of the MPM. The bitstreams are decompressed by the MPM/SC device before they are sent out over the data pins to the FPGA devices.

Adding Files to System ACE Devices

The last stage of the wizard enables you to add the individual configuration files you wish to be included in the System ACE file.

Note The same startup clock restrictions that apply for configuring devices with a cable also apply to adding bitstreams to the System Ace files. For System ACE CF, only bitstreams with startup clock settings of Boundary-Scan (JTAG) Clock are allowed. For System ACE MPM, only bitstreams with startup clock settings of CCLK are allowed.

The Add Files wizard sequence first takes you through adding devices in a single Configuration Address space (revision). When you have added all of your files in the current revision, click No when you see the dialog that looks similar to the one in Figure 5-3.

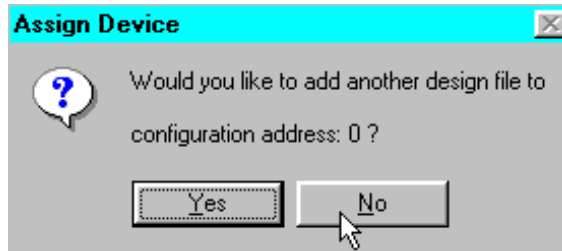

Figure 5-3 Assign Device Dialog Box

The wizard then moves to the next configuration address that you enabled earlier in the wizard sequence, and enable you to assign files to the devices shown in this address space. Follow the sequence until all desired files have been added.

System ACE CF

The following section provides specific information for System ACE CF operations.

System ACE CF Screen

Figure 5-4 shows the System ACE screen for a typical CF design. Moving your mouse over different areas of the screen reveals details specific to that area. There are three basic areas of the screen:

1. The collection table at the top.
2. The chain description area in the center.
3. The System ACE area at the left.

In the Figure below, three different areas are shown. When moving the mouse over a configuration address, the configuration size for that address displays. Moving your mouse over the "Collection:" row of the table near the top of the screen displays a detailed summary for that collection. Moving your mouse over a device in the chain shows the size of that bitstream, and moving your mouse over the Compact Flash icon shows detailed size information for the total CF design, including all collections and any reserve space specified. Also, a tally of total utilization is always displayed under the System ACE CF icon.

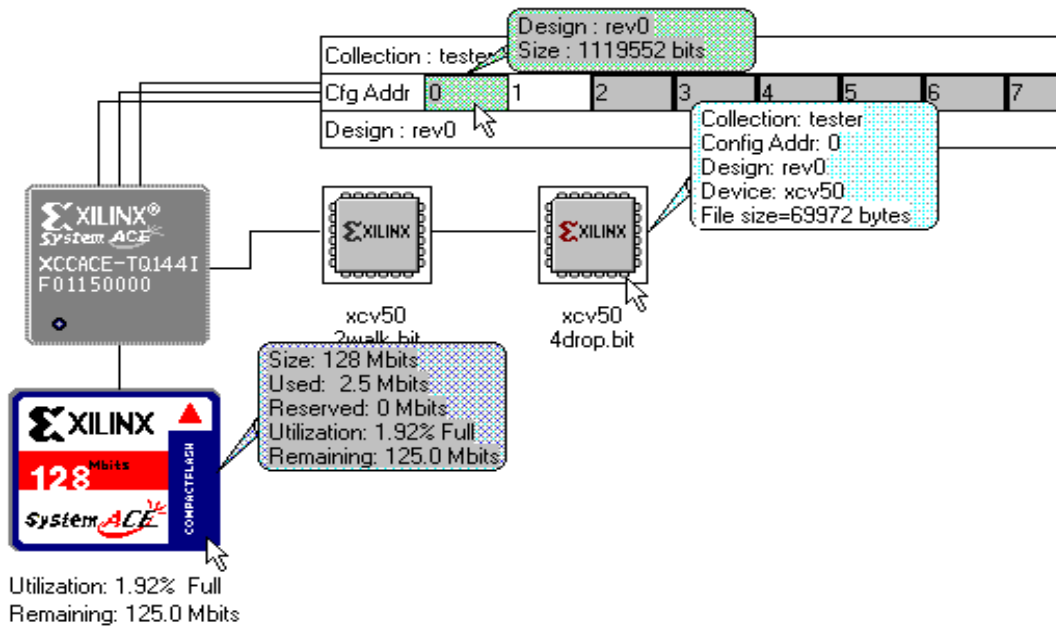

Figure 5-4 System ACE Screen for a CF Design

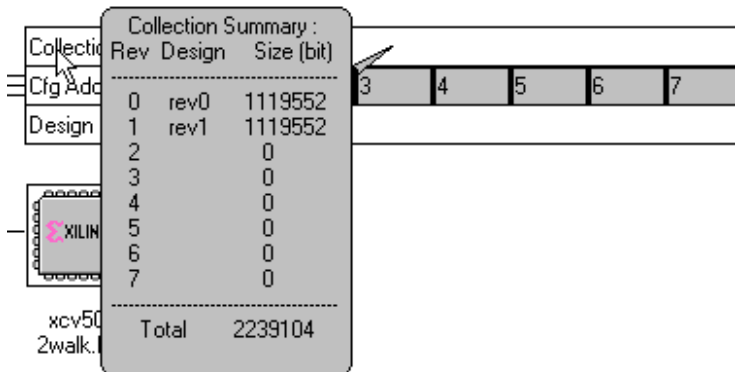

Figure 5-5 Collection Summary for a CF Design

Viewing Different Configuration Addresses

In the collection table, there is a row titled "Cfg Addr" which also is referred to as revisions. Each revision that is not being used is grayed out and cannot be selected. Left-clicking your mouse on an active (lighter colored) revision name selects this revision and displays the contents of the chain in the center of the window.

Adding More Devices After the Wizard Has Finished

In a blank portion of the chain description portion of the screen, right-click or use the **Edit** menu to select **Add Xilinx Device**. A dialog box appears that enables you to select a bitstream to add to the chain.

Note If you are in Novice Mode for System ACE CF devices, adding a device to one revision also adds a device to all revisions. In this case, a wizard appears and assists in assigning files to the other revisions.

Assigning a Different File to a Device

If you wish to change the file that is assigned to a certain device, you can double-click the device and the Assign New Configuration File dialog appears. This dialog can also be accessed by selecting the device and right-clicking or by using the **Edit** menu to select **Assign Configuration File**.

Managing Multiple Collections

System ACE CF devices enable you to store multiple collections on the Compact Flash device. However, only one collection, called the "active collection," is available to be loaded into FPGA devices by the System ACE CF controller. The decision on which collection is active is made when you actually generate the System ACE file. See "Generating the System ACE CF File" section for more information.

In a blank section of the chain description portion of the screen, right-click or use the **Edit** menu to select **Add Collection**, **Delete Collection**, **List All Collections**. **Add Collection** opens the Wizard at the collection name input screen, and the wizard proceeds from there to take you through the steps of adding files to your newly created collection.

To switch to a different collection, use **List All Collections**. This menu item displays the dialog box shown in Figure 5-6. The

drop down list enables you to select which collection you wish to work on and clicking OK makes that collection current.

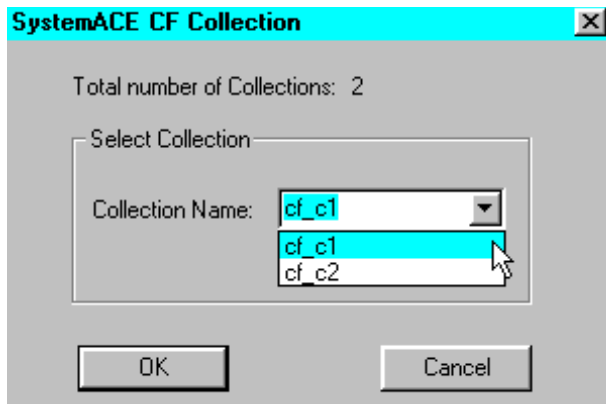

Figure 5-6 SystemACE CF Collection Dialog Box

To delete a collection, use the **Delete Collection** menu item. This brings up the list dialog shown in Figure 5-6. Clicking OK on this dialog box causes the selected collection to be deleted from iMPACT's current session. However, this command does not delete previously generated System ACE CF files from your disk.

Generating System ACE CF Files

To generate a System ACE CF fileset, right-click in a blank space in the Chain Description area, or from the **Operations** menu, select **Generate File**. This opens the dialog shown in Figure 5-7. Here you can select the active collection. Click OK to generate the file.

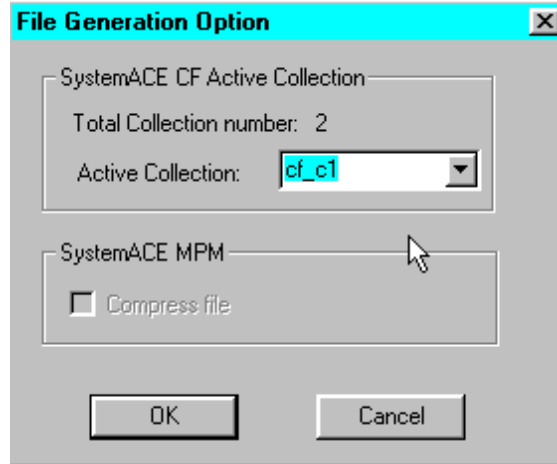

Figure 5-7 File Generation Option Dialog Box

System ACE MPM

The following section provides specific information for System ACE MPM operations.

System ACE MPM Screen

Figure 5-8 shows the System ACE screen for a typical MPM Slave Serial Mode design and Figure 5-9 shows the screen for a typical SelectMAP design. Moving your mouse over different areas of the screen reveals details specific to that area. There are four basic areas of the screen:

1. The Configuration Address (Revision) table at the top.
2. The chain description area in the center.
3. The Chip Select or Serial Data Stream selection area to the near left.
4. The System ACE MPM area at the far left.

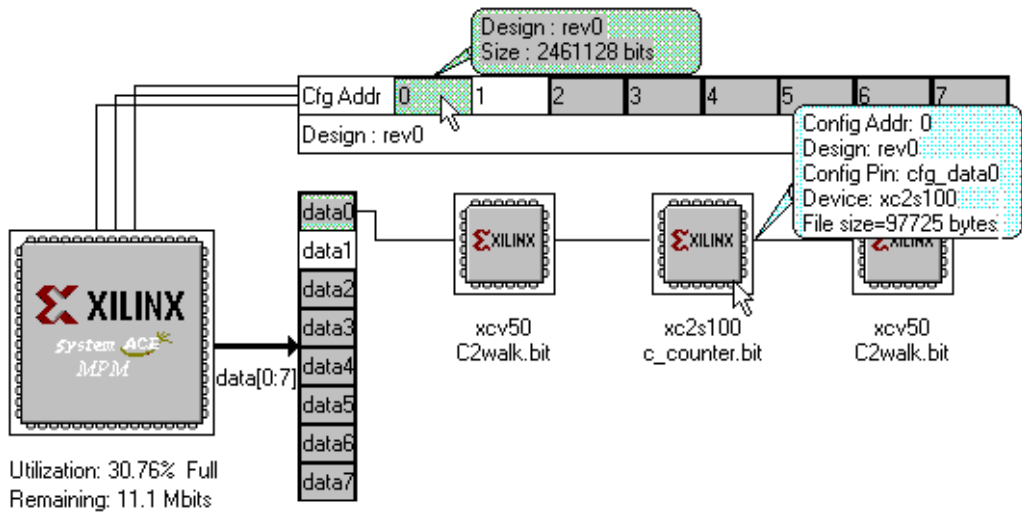

Figure 5-8 System ACE Screen for an MPM Slave Serial Design

In Figure 5-8, three different areas are shown. When moving the mouse over a configuration address, the configuration size for that address is shown. Moving your mouse over a device in the chain shows the size of that bitstream. In Slave Serial Mode, moving your mouse over a data pin shows the size of the chain connected to that pin.

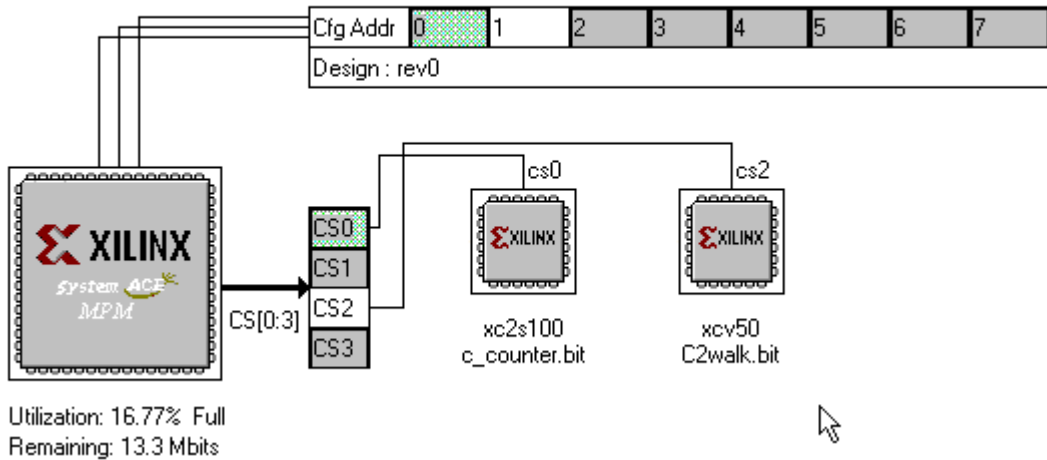

Figure 5-9 System ACE Screen for an MPM SelectMAP Design

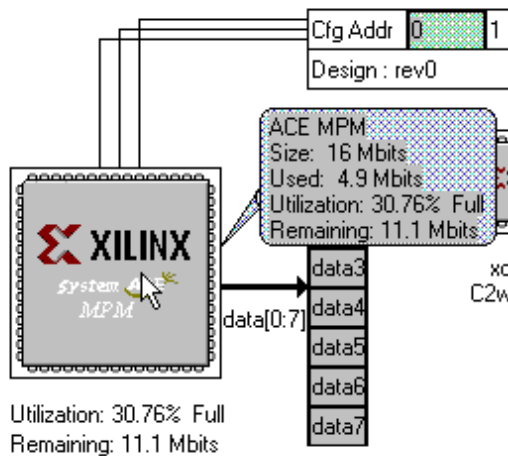

Figure 5-10 System ACE MPM Design Size Information

As shown in Figure 5-10, moving your mouse over the MPM icon shows detailed size information for the total MPM design, including any reserve space specified. Also, a tally of total utilization is always displayed under the MPM icon.

Viewing Different Configuration Addresses

In the collection table, there is a row titled "Cfg Addr." Each configuration address is commonly referred to as a revision. Each revision that is not being used is grayed out and cannot be selected. Left-clicking your mouse on an active (lighter colored) revision number selects this revision and displays the content of the chain in the center of the window.

Adding More Devices After the Wizard Has Finished

In a blank section of the chain description portion of the screen, right-click or use the **Edit** menu to select **Add Xilinx Device**. A dialog box appears that enables you to select a bitstream to add to the chain.

Assigning a Different File to a Device

If you wish to change the file that is assigned to a certain device, you can double-click the device and the Assign New Configuration File dialog box appears. This dialog can also be accessed by selecting the device and right-clicking or by using the **Edit** menu to select **Assign Configuration File**.

Generating System ACE MPM Files

To generate a System ACE MPM file, right-click in a blank space in the Chain Description area, or from the **Operations** menu, select **Generate File**. This opens the dialog shown in Figure 5-11. Here you turn on the file compression by checking the **Compress File** box. Click OK to generate the file.

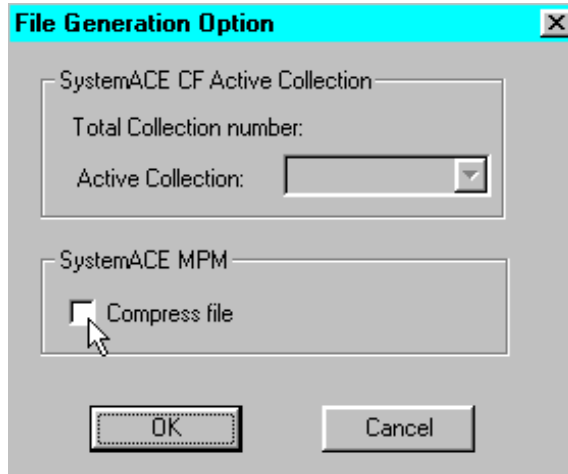

Figure 5-11 File Generation Option Dialog Box

Creating PROM Formatter Programming Files

The following section describes how to generate PROM files using the PROM Formatter in the File Generation mode of iMPACT.

General PROM File Information

This section provides general background information on PROMs and PROM files. For instructions on using PROM Formatter, go to [“PROM Formatter Operations”](#).

PROMs

There are two types of PROMs supported in iMPACT: Xilinx Serial PROMs and 3rd-party parallel PROMs. Xilinx Serial PROMs are designed to work with Xilinx FPGAs in a master-serial daisy-chain. Parallel PROMs are most commonly used in conjunction with CPLDs or microprocessors to program FPGAs in a daisy chain where the first device is in Slave Parallel Mode. Multiple data streams are only allowed in Parallel PROM mode.

PROM Formatter Files

Input Files

You can input one or more BIT files into the PROM Formatter. A BIT file contains configuration information for a single FPGA device.

Output Files

The PROM Formatter generates the following files as outputs:

- PROM files—The file or files containing the PROM configuration information. Depending on the PROM file format your PROM programmer uses, you output a TEK, MCS, or EXO file. If you are using a microprocessor to configure your devices, you output a HEX file.

If the data in the PROM Formatter is going to be split into multiple PROMs, there is a PROM file corresponding to each PROM.

- PRM file—An ASCII file containing a memory map of the output PROM file. If the data in the PROM Formatter is split into

multiple PROM files, there is a PROM file corresponding to each PROM.

The following is a sample PRM file.

```
PROM /design/fpga1/fpga100.prm map: Fri Feb 21
    11:00:50 1998
Format      Mcs86
Size        32K
PROM start  0000:0000
PROM end    0000:7fff
            Addr1      Addr2 File(s)
0000:0000   0000:7fff /design/fpga1/fpga1.bit
```

BIT Swapping in PROM Files

The PROM Formatter produces a PROM file in which the BITS within a byte are swapped compared to the BITS in the input BIT file. BIT swapping (also called “BIT mirroring”) reverses the BITS within each byte, as shown in the following figure.

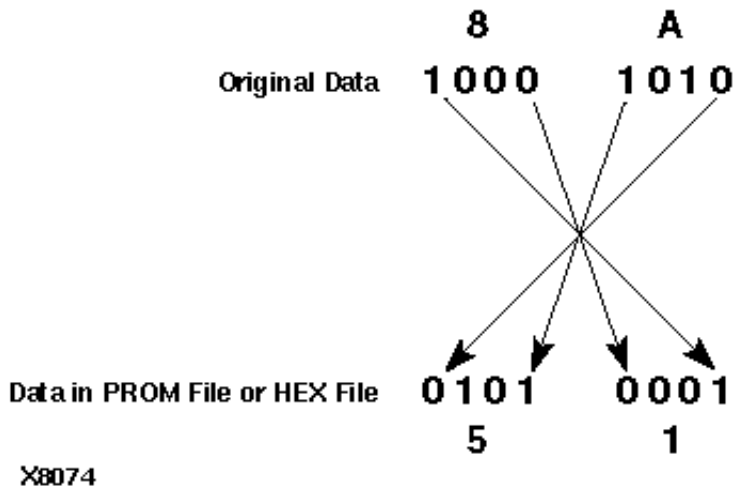

Figure 5-12 BIT Swapping

In a bitstream contained in a BIT file, the Least Significant BIT (LSB) is always on the left side of a byte. But when a PROM programmer or a microprocessor reads a data byte, it identifies the LSB on the right side of the byte. In order for the PROM programmer or microprocessor to read the bitstream correctly, the BITS in each byte must first be swapped so they are read in the correct order.

The BITS are automatically swapped for all of the PROM formats: MCS, EXO, and TEK. For a HEX file output, BIT swapping is on by default, but it can be turned off by deselecting a Swap BITS option that is available only for HEX file format.

Implementing Your Applications

You use the PROM Formatter to generate a PROM file containing data to configure a single FPGA device, or a PROM file to configure one or more groups of FPGA devices. You can also store multiple data streams in the same PROM file and use these data streams to reconfigure a device or daisy chain for different applications.

The following table summarizes the various ways of structuring a PROM file.

Table 5-1 Configuration Data Stream Combinations

| Number of Applications | Number of FPGA Devices to Configure | Number of Data Streams and BIT Files |
|---------------------------------------|---|---|
| Single Application | Single device | One data stream with a single BIT file |
| | Daisy chain of devices | One data stream with multiple BIT files |
| | Multiple daisy chains of devices ^a | Multiple data streams with multiple BIT files in each data stream. Each data stream includes configuration data for a different daisy chain of devices. |
| Multiple Applications (Reprogramming) | Single device | Multiple data streams with a single BIT file in each data stream |
| | Daisy chain of devices | Multiple data streams with multiple BIT files in each data stream. Each data stream programs the group of devices for a different application |

- a. This type of application can be implemented with a byte-wide PROM only. Each data stream uses a different start-up address in the PROM file.

Single Application PROM Files

There are three different types of configuration data streams.

- **Single Device**
To implement an application for a single device, use a data stream containing a single BIT file.
- **One group of daisy-chained devices**
To implement an application for a group of FPGA devices connected together in a daisy chain, use a single data stream containing multiple BIT files; that is, one BIT file for each device in the daisy chain.
- **Several groups of daisy-chained devices**
To implement an application for several groups of daisy chained devices, you must build one data stream per daisy chain. This type of implementation is valid for byte-wide PROMs, which can be set for different start-up addresses, or for creating a bitstream for microprocessor download.

Multiple Application PROM Files

The Xilinx SRAM FPGA technology enables you to design multiple applications for a single device or a daisy chain of devices. Each data stream in the PROM description area represents a different configuration or application for the same device or daisy chain of devices.

To implement several applications for a single device, build a PROM file made of several data streams, with each data stream containing a single BIT file. To implement several applications for a group of daisy chained devices, use several data streams containing multiple BIT files. Each data stream programs the group of devices for a different application.

Note The number of BIT files within each data stream must be the same.

Configuration Setups

For information on setups for configuring FPGA devices and daisy chains for a single application, refer to The Programmable Logic Data Book.

XILINX PROM Part Names

The part name for a Xilinx serial configuration PROM indicates the PROM's size and type. The fields in the part name are described in the following figure.



Notes:

1. XC18V04 and XC18V02 only.
2. XC18V01, XC18V512, and XC18V256 only.

Figure 5-13 PROM Device Names

PROM Formatter Operations

The following section explains the properties on the wizard screens for PROM files. After setting the properties, you are prompted to add devices to the configuration chain or chains. As the final step in the wizard, you are asked if you want to generate the PROM file. If you click "No", you can always generate the file later by using the Operations Menu.

Serial PROM Settings

Select Serial PROM

There are two fields that make up this selection. The first, which defaults to the value of 17V, is the PROM family. PROMs in each of the Xilinx 1700 families are one-time programmable. The flash-based

in-system re-programmable PROMs are called the 18V family. Once a family is selected, the drop-down list for the individual PROMs enable you to select the exact PROM you are using. The primary reason for selecting a PROM size is that you want iMPACT to automatically perform a capacity check. If that is desired, select a size, and click the Add button.

Auto Select PROM

If you want iMPACT to automatically choose the correctly sized PROM for you, turn on this checkbox (off by default).

Note PROM files are compatible across same-sized devices (i.e. a PROM file fit to an XC17512 will also work in an XC18V512).

Add button

This button adds the selected PROM to the list of PROMs in the box below the button. For multiple PROMs (also called a PROM daisy-chain), select the next PROM you want to use and select the add button. This second PROM starts at position 1. iMPACT limits you to a maximum of 32 serial PROMs in a chain.

Parallel PROM Settings

Select Parallel PROM Density

In the drop-down list, there are common PROM densities listed, up to 32 Mbytes. If you want iMPACT to automatically perform a capacity check, select a size, and click the Add button.

Auto Select PROM

If you want iMPACT to automatically choose the correctly sized PROM for you, turn on this checkbox (off by default).

Note PROM files are compatible across same-sized devices (i.e. a PROM file fit to an XC17512 will also work in an XC18V512).

Add Button

This button adds the selected PROM to the list of PROMs in the box below the button. For multiple PROMs select the next PROM you want to use and select the **Add** button. This second PROM starts at position 1. iMPACT limits you to a maximum of 32 PROMs.

Number of Data Streams (1-64)

For parallel PROMs, it is possible to utilize multiple configurations, or revisions, and store these in the parallel PROM. Typically, this is controlled with a microprocessor or other external logic, and each serial chain is referred to as a "data stream".

Loading Direction

This determines whether the PROM data is placed at sequentially higher addresses (UP), or if they are placed at sequentially lower addresses (DOWN).

Fill Value

When fitting the files to the PROM, the fill value indicates the unfilled space. The value will fill the unused bit in the file and may change the checksum.

Adding Files to PROM Devices

The last stage of the wizard enables you to add the individual FPGA configuration files you wish to be included in the PROM file.

Note The same startup clock restrictions that apply for configuring devices with a cable also apply to adding bitstreams to PROM files. For PROM files, only bitstreams with startup clock settings of CCLK are allowed.

The Add Files wizard sequence takes you through adding devices in a single Data Stream. If you are using a parallel PROM, and you have more than one data stream, you are then directed to enter the devices and the starting address for further data streams as shown in Figure 5-14. Follow the sequence until all desired files in all Data Streams have been added.

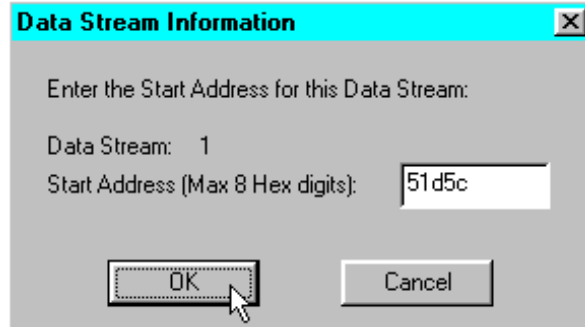

Figure 5-14 Data Stream Information Dialog Box

Generating PROM Files

To generate PROM files from the main PROM screens, right-click in a blank space in the Chain Description area, or from the Operations menu, select **Generate File**.

Serial PROM File Creation

The following section gives specific information on creating Serial PROM files.

Serial PROM Formatter Screen

Figure 5-15 shows the Serial PROM Formatter screen for a typical design. The PROM order is from top to bottom, with the PROM on top being the one that is read from first. Moving your mouse over a device in the chain shows the size of that bitstream. A tally of total utilization is always displayed under each PROM icon.

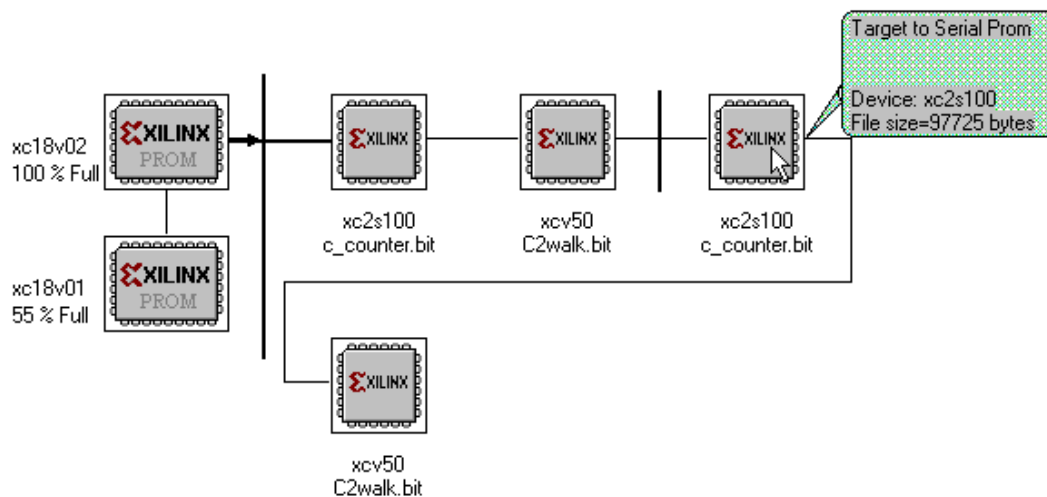

Figure 5-15 PROM Formatter Screen for a Serial PROM

Adding or Deleting FPGA Devices After The Wizard Has Finished

To add an FPGA device, right-click in a blank portion of the screen or use the **Edit** menu to select **Add xilinx Device**. A dialog box appears that enables you to select a bitstream to add to the chain. To delete an FPGA, select the device by clicking on it, and then press the Delete key on the keyboard.

Adding or Deleting Serial PROM Devices After The Wizard Has Finished

To add a PROM, right-click in a blank portion of the screen or use the **Edit** menu to select **Add PROM**. A dialog box appears that enables you to select a new PROM to add to the serial PROM chain. To delete a PROM, select the device by clicking on it, and then press the Delete key on the keyboard, or use the **Edit** or right-click menus to select **Delete PROM**.

Assigning A Different File To A Device

If you want to change the file that is assigned to a certain device, you double-click the device and the Assign New Configuration File dialog box appears. This dialog can also be accessed by selecting the device and right-clicking or by using the **Edit** menu to select **Assign Configuration File**.

Modifying PROM Sizes

Double-click on the PROM you wish to change, or use the **Modify PROM** command under the **Edit** or right-click menus. A dialog appears that enables you to select a different PROM.

Parallel PROM File Creation

The following section gives specific information on creating Parallel PROM files.

Parallel PROM Formatter Screen

Figure 5-16 shows the Parallel PROM Formatter screen for a typical design. There are three basic areas of the screen:

- The Data Stream table at the top
- The chain description area in the center
- The PROM area at the left.

The PROM order is from top to bottom, with the PROM on top being the one that is filled first. Moving your mouse over an active data stream gives size information and the starting address for that data stream. Moving your mouse over a device in the chain shows the size of that bitstream. A tally of total utilization is always displayed under the each PROM icon.

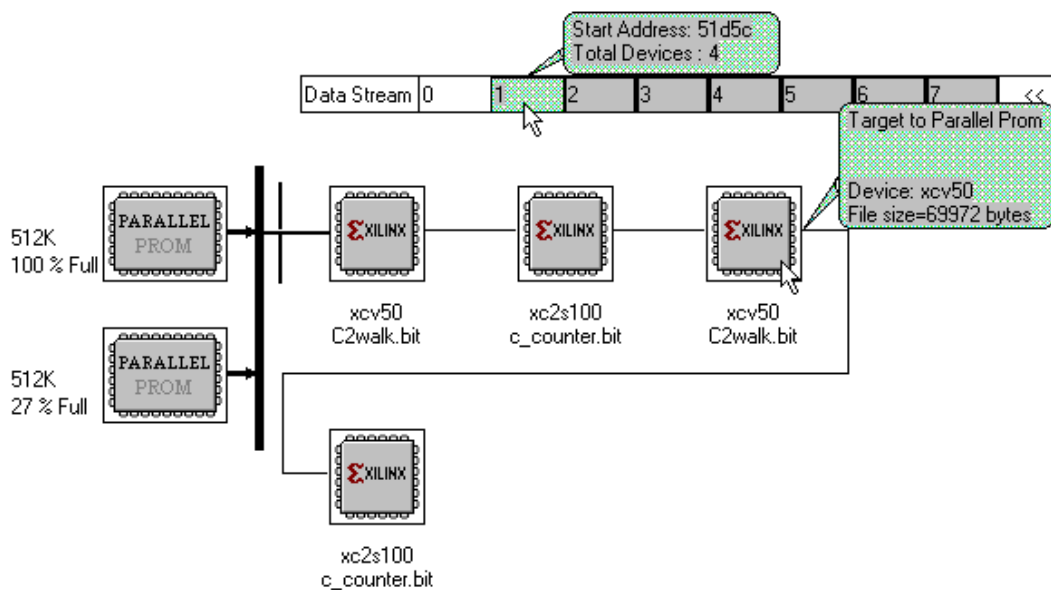

Figure 5-16 PROM Formatter Screen for a Parallel PROM

Viewing Different Data Streams

In the Data Stream table at the top of the screen, notice that each data stream that is not being used is grayed out and cannot be selected. Left-clicking your mouse on an active (lighter colored) data stream selects this stream and displays the contents of the chain in the center of the window. You then are able to modify this stream by the editing methods described below.

Adding or Deleting FPGA Devices After The Wizard Has Finished

To add an FPGA device, right-click in a blank portion of the screen or use the **Edit** menu to select **Add Xilinx Device**. A dialog box appears that enables you to select a bitstream to add to the chain. To delete an FPGA, select the device by clicking on it, and then press the Delete key on the keyboard.

Adding or Deleting Parallel PROM Devices After The Wizard Has Finished

To add a PROM, right-click in a blank portion of the screen or use the **Edit** menu to select **Add PROM**. A dialog box appears that enables you to select a new PROM to add to the parallel PROM area of the screen. To delete a PROM, select the device by clicking on it, and then press the Delete key on the keyboard, or use the **Edit** or right-click menus to select **Delete PROM**.

Assigning A Different File To A Device

If you want to change the file that is assigned to a certain device, you double-click the device and the Assign New Configuration File dialog box appears. This dialog can be accessed by selecting the device and right-clicking or by using the **Edit** menu to select **Assign Configuration File**.

Modifying PROM Sizes

Double-click the PROM you wish to change, or to select a PROM use the **Modify PROM** command under the **Edit** or right-click menus. A dialog box appears that enables you to select a different PROM size.

Creating an SVF or STAPL File

To create an SVF or STAPL file, the File mode must be selected. A cable does not need to be connected because operations are not being performed on devices; all of the configuration information is written to the SVF or STAPL file.

Creating the chain

Before creating the SVF or STAPL file, the Boundary-Scan chain must be created. Refer to the section on "Manually Creating the Chain" for the Boundary-Scan Configuration Mode. The method of adding devices is the same as described in this section. In addition, a chain previously defined in Boundary-Scan mode can be automatically copied to the SVF/STAPL mode window.

Selecting the Programming File

After the chain has been fully described, right-click on a blank area of the window and select **Create SVF File** or **Create STAPL File**

(see Figure 5-17). This brings up a window that enables you to select a name for your programming file and specify the location for this file. After selecting the name and location, the SVF or STAPL file is ready to be written to.

Right click device to select operations

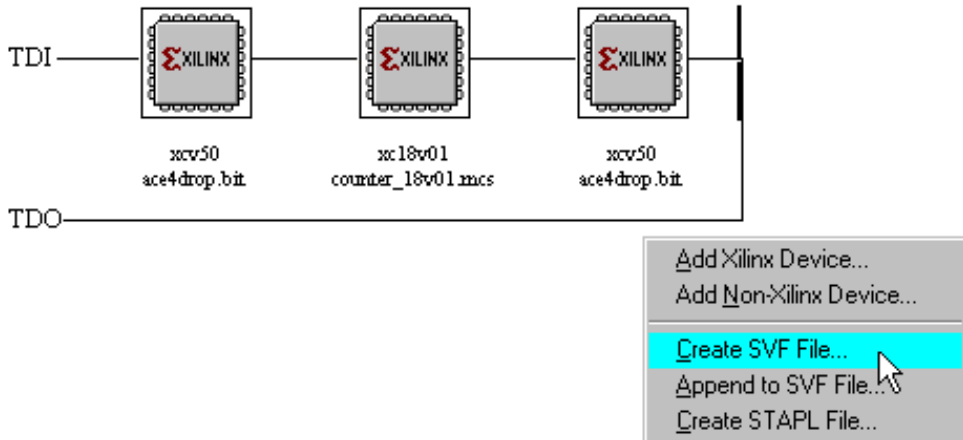

Figure 5-17 Selecting a SVF or STAPL File

Writing to an SVF or STAPL File

The process for writing to an SVF or STAPL file is identical to performing Boundary-Scan operations with a cable. You simply right-click on a device and select an operation. For instance, in Figure 5-18, the user right-clicked on the first device in the chain and left-clicked on **Get Device ID**. The instructions that are necessary to perform a Get Device ID operation is then written to the file. Figure 5-19 shows what the SVF file looks like after the **Get Device ID** operation is performed.

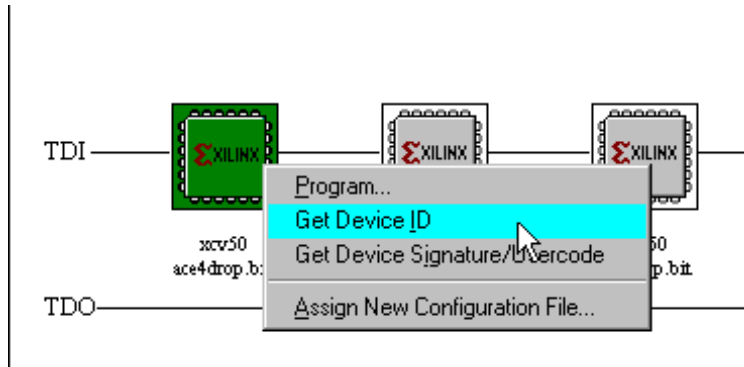

Figure 5-18 Selecting Boundary-Scan Operation

```
Device #1 selected
Validating chain...
Boundary-scan chain validated successfully.
'1': IDCODE is '11110000011000010000000010010011'
'1': IDCODE is 'f0610093' (in hex).
```

Figure 5-19 SVF File That Gets a Device ID from the First Device in the Chain

Any number of operations can be written to an SVF or STAPL file. For instance, after selecting **Get Device ID** for the first device in the chain, you select the second device in the chain and select the **Program** option. The instructions and configuration data needed to Program the second device are added to the file.

After all the desired operations are performed, right-click in a blank area of the window and select **Close SVF File** or **Close STAPL File** (See Figure 5-20). This closes the file so that no more information can be written to it.

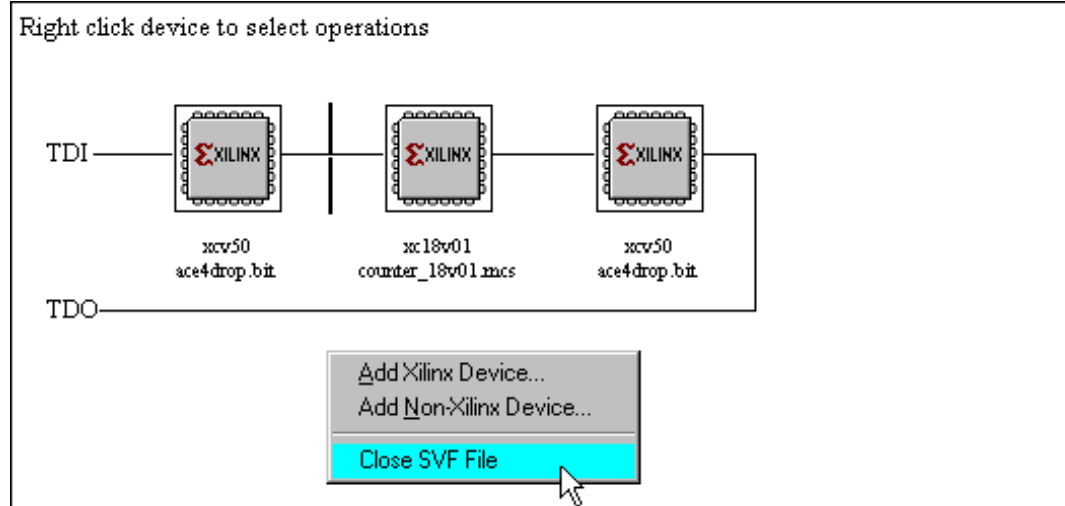

Figure 5-20 Closing the SVF File

To add additional operations in the future, right-click and select **Append to SVF File**.

Note STAPL files do not support appending.

Troubleshooting for Boundary-Scan Chains

This chapter contains the following sections.

- “Communication”
- “Improper Connections”
- “Improper or Unstable Vcc”
- “Boundary-Scan Chain Debug”
- “System Noise”

Communication

Observing the following guidelines should minimize the communication difficulties that can occur between the cable hardware and the target system.

- Do not attach extension cables to the target system side of the cable; this can compromise configuration data integrity and cause checksum errors.
- Attach the cable configuration leads firmly to the target system.
- After connecting the target system, specify the Boundary-Scan chain configuration by adding a device (**Edit** → **Add Device** → **Xilinx Device**). Then use the "partinfo -id part_name" command to read the IDCODE from each part in the system. This verifies the integrity of the Boundary-Scan chain.
- Then read the IDCODE value of the device (**Operations** → **Get Device ID**). This verifies the integrity of the configuration data.
- After a device has been configured, use the verify operation (**Operations** → **Verify**) to assure integrity of the configuration data. You can do this from the command line with the -v

option or in the interactive mode by specifying the verify command.

Improper Connections

Check the following:

- Always make sure that cable leads are connected properly.
- Connecting the cable leads to the wrong signal causes permanent damage to cable internal hardware. On a parallel cable, you must connect Vcc to +5 V, +3.3V or +2.5V, and GND to ground.
- Make sure the Parallel Cable IV's modular power connector is connected to a PC or external power source.
- For workstations, you must have read and write permissions to the port to which you connect the cable. iMPACT might issue a message stating that the cable is not connected to port ttyx. When you see this message, follow the checklist below:

- ◆ The board must have the power on, since the cable uses power from the board.
- ◆ Check if the specific port is valid and if not, reconnect the cable to a valid port.
- ◆ Check the device driver using the following command string:

```
ls -l /dev/ttya /dev/ttyb
```

The result should be the following:

```
crw-rw-rw- 1 root12,0 month date time /dev/ttya
```

```
crw-rw-rw- 1 root12,1 month date time /dev/ttyb
```

- ◆ Read the /etc/ttytab file. There should be two lines, as follows:

```
ttya"/usr/etc/getty std.9600" unknown off local secure  
ttyb"/usr/etc/getty std.9600" unknown off local secure
```
- If you use a port to connect a modem or a remote login, you cannot use that port. The port must be on. Consult your System Administrator if the information in the /etc/ttytab file is different than what is listed in the aforementioned list.

Improper or Unstable Vcc

If you are having problems with unstable Vcc, try the following:

Never connect the control signals to the cable before Vcc and ground. Xilinx recommends the following sequence:

- Turn off power to the target system.
- Connect the Parallel Cable IV's modular power cable to a power source.
- Connect Vcc ground, and then the signal leads.
- Turn on power to the target system.
- Make sure that Vcc rises to a stable level within 10msec. The stable Vcc level should be within 5% of the targets VccIO.
- In the event of power glitches, reset the cable by selecting:

`Output →Cable Reset`

Boundary-Scan Chain Debug

If you experience a consistent error that identifies a break in your Boundary-Scan chain but are unable to identify such a discontinuity, execute the following steps:

1. Use the **Operations** →**IDCODE Looping** function to shift out a Device IDCODE repeatedly. Use the default loop count (10000) to begin this procedure.

iMPACT executes the IDCODE instruction and data shift 10000 times before quitting.

2. Use an oscilloscope or logic analyzer to probe the pins of the Boundary-Scan test access port (TAP) at each individual device.
3. Probe the TDO and watch for the following two data patterns:

The instruction capture value (once)

The IDCODE value (10000 times)

The IDCODE looping operations sequences the TAP through a TMS reset sequence (TMS set to 1, TCK pulsed 5 times) and then transitions the TAP to the RunTest/Idle state (TMS set to 0, TCK pulsed once).

Then the TAP is transitioned to the Shift-IR state and the IDCODE instruction is shifted into the device. As this value is shifted in, the instruction capture value is shifted out. For all XC9500/XL/XV devices this sequence is a "1" followed by seven zeroes (this value can be read from the device's BSDL file). You should therefore see a "1" on TDO after the falling edge of the 4th TCK pulse after transitioning out of the RunTest Idle state.

The CAPTURE -IR sequence consists of the following (starting from RunTest/Idle), as illustrated in Figure 6-1.

TMS set to 1; TCK pulsed twice.

TMS set to 0; TCK pulsed twice.

TCK pulsed (number of bits in instruction register -1) times.

TMS set to 1; TCK pulsed twice.

TMS set to 0; TCK pulsed once.

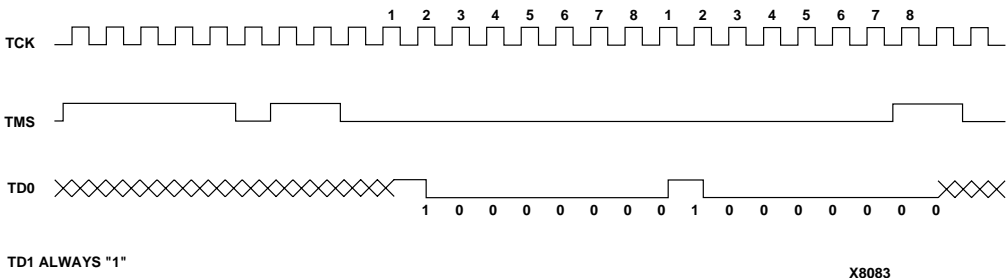

Figure 6-1 Sample Expected Waveform

Check for the following:

- The expected number of TCK pulses occur.
- The same TMS sequence occurs for each part.
- The TDO is not shorted or floating between parts, or floating at the system interconnect point.
- Make certain that all 4 TAP signals are getting into each part (Note that both TDI and TMS have internal pull-ups on them which could keep the device in TRST mode if TMS is not properly connected).

You can also use the Boundary-Scan Chain Debug dialog and a logic probe or oscilloscope to transition the TAP state machine directly and observe results.

The IDCODE value (which can be determined from the device's BSDL file) is visible each time the TAP is in the Shift-DR state.

System Noise

You can check for system noise by running the IDCODE looping instruction. The IDCODE should read correctly 100% of the time. If by test you find that the instruction is working less than 100% of the time, you may be experiencing system noise. To use IDCODE looping:

Operations →IDCODE Looping

This displays the Edit window. Enter the number of loops you desire and click OK.

To remedy a problem with system noise, select Use HIGHZ instead of BYPASS from the Preferences dialog box. This places devices into tri-state mode and reduces susceptibility to system noise. To find this box use:

Edit →Preferences

- The Preferences dialog box appears. Place a check in the box adjacent to Use HIGHZ instead of BYPASS.

Glossary of Terms

This glossary contains definitions and explanations for terms commonly used in the iMPACT program.

ACE Flash

The Xilinx ACE Flash memory card is a CompactFlash solid-state storage device with an on-card intelligent controller that manages interface protocols, data storage and retrieval, ECC, defect handling and diagnostics, power management, and clock control.

BIT file

A synonym for a configuration bitstream file.

bitstream (BIT file)

A data stream, also called BIT file, that contains location information of logic on a device, that is, the placement of CLBs, IOBs, TBUFs, pins, and routing elements. The bitstream also includes empty placeholders that are filled with the logical states sent by the device during a readback. Only the memory elements, such as flip-flops, RAMs, and CLB outputs, are mapped to these placeholders, because their contents are likely to change from one state to another. When downloaded to a device, a bitstream programs the device.

A bitstream file has a .bit extension.

Boundary-Scan

Boundary-Scan mode is the method used for board-level testing of electronic assemblies. The primary objectives are the testing of chip I/O signals and the interconnections between ICs. It is the method for observing and controlling all new chip I/O signals through a standard interface called a Test Access Port (TAP). The Boundary-

Scan architecture includes four dedicated I/O pins for control and is described in IEEE spec 1149.1.

byte wide PROM

A PROM that is read one byte at a time. The other PROM type is a serial PROM, which is read one bit at a time.

CCLK pins

The pin of the configuration cable that connects the configuration clock to the device.

CFG_DONE pin

The CFG_DONE pin is a MultiLINX Target Interface Pin.

CFG_RDY pin

When asserted, this pin indicates that the FPGA is ready to receive configuration data. When de-asserted, the pin indicates that either the FPGA is in the power-up mode, or a configuration error has occurred. The CFG_RDY pin is a MultiLINX Target Interface Pin.

CFG_RESET pin

The CFG_RESET pin is a MultiLINX Target Interface Pin.

console log

A record of the commands that you executed during an iMPACT session.

CS/CS0 pin

CS on the Virtex. The CS/CS0 pin represents a chip select to the target FPGA during configuration. The CS/CS0 pin is a MultiLINX Target Interface Pin.

CS1 pin

The CS1 pin is a MultiLINX Target Interface Pin.

CS2 pin

The CS2 pin is a MultiLINX Target Interface Pin.

daisy chain

In the context of iMPACT, a data stream used to configure a set of devices that are connected in series such that the Dout pin of a device in the daisy chain is connected to the DIN pin of the next device. You can generate a daisy chain data stream by concatenating two or more bitstreams (BIT files) together using the PROM Formatter tab in the File Generation mode of iMPACT.

data stream

In the context of the PROM Formatter, a data stream is a collection of one or more concatenated BIT files used to implement a single user application. To implement multiple applications, concatenate data streams — one data stream per application — to form a multiple data stream PROM file that enables you to reprogram a single FPGA or a daisy chain.

debugging

The process of reading back or probing the states of a configured device to ensure that the device is behaving normally while in circuit.

DIN pin

The Data In pin of the configuration cable connects to the DIN pin of your target device. In serial mode, the DIN pin loads the bitstream data to the target FPGA.

DONE pin (Virtex/Spartan-II)

This pin connects to the DONE pin of your target FPGA. It indicates the completion of the configuration process. During configuration, this pin is Low. After configuration, this pin is High.

downloading

Configuring or programming a device by sending bitstream data to the device.

D0-D7 pins

An 8-bit data bus supporting the Express and SelectMAP configuration modes. The D0-D7 pins are MultiLINUX Target Interface Pins.

DOUT pin

Provides configuration data to downstream devices in a daisy-chain. The pin becomes a user I/O after configuration.

EXORmacs (Motorola)

A PROM file format supported by the Xilinx tools. Its maximum address is 16,777,216. This format supports PROM files of up to $(8 \times 16,777,216) = 134,217,728$ bits.

Express Mode

FPGA configuration mode (XC5200 only) in which configuration data is loaded into the FPGA in parallel; one byte per clock cycle instead of one bit per clock cycle.

GND pin

Ground (0 volt) pin of the configuration cable. This pin connects to the Ground pin of a power supply.

hexidecimal format (HEX)

An ASCII hexadecimal version of the PROM data. It has unlimited data capacity.

INIT pin

Initialization pin on your configuration cable. This pin is connected to the INIT pin of your target device indicating when a device is ready to receive configuration data after power up. During configuration, INIT=0 indicates a configuration error.

loading direction

The direction in which data is stored on your PROM. In the Up direction, the data is stored in ascending order, starting at a low address. In the Down direction, the data is stored in descending order, starting at a high address.

MCS-86 (Intel)

An Intel PROM format supported by the Xilinx tools. Its maximum address is 1,048,576. This format supports PROM files of up to $(8 \times 1,048,576) = 8,388,608$ bits.

(.msk) file

The mask file, (.msk) file indicates which bits are configuration bits and which ones are not. This file is needed to do a verify operation on a Virtex family device using the MultiLINX Cable. This file is generated during the implementation process (BitGen) if readback is enabled in the “Configuration Template”.

main window

The background against which other windows are displayed in iMPACT.

The area located at the top of the iMPACT window. It includes the File, Edit, Mode, Operations, Options, Output, View, and Help menus.

PROG pin

The Program pin of your configuration cable provides a reprogram pulse to devices when connected to the PROG pin of the device.

PROM file

A PROM file is the file output by the PROM Formatter tab in the File Generation mode of iMPACT, which can be used to program one or more devices. iMPACT supports the following PROM file formats: MCS (Intel MCS-86), EXO (Motorola EXORMacs), TEKHEX (Tektronix hexadecimal).

PROM description area

The area located on the left side of the PROM Formatter window. The area shows the structure of your PROM file. It is a hierarchical view of the data streams and BIT files in the PROM file.

PROM description (PDR) file

An ASCII report file listing all the data streams and BIT files used to construct the PROM file, as well as the load direction and PROM file splitting information. The PROM Formatter uses this file to determine the structure and properties you have specified for the PROM file.

RBT file

A raw BIT format file, the ASCII version of the BIT file.

readback

The process of reading the logic downloaded to an FPGA device.

- A readback with a filter that extracts the configuration bits to verify that a design was downloaded correctly.

RD (TDO) pin

The readback data pin of the MultiLINX Cable. This pin connects to the RDATA pin of the device. When connected, the pin reads data from the programmed target device.

RDWR pin

The RDWR pin is used as an active high READ and an active low WRITE control signal to the Virtex FPGA. The RDWR pin is a MultiLINX Target Interface Pin.

RDY/BUSY pin

The RDY/BUSY pin is a MultiLINX Target Interface Pin. This pin controls the rate at which configuration data is loaded.

RS pin

The RS pin is a MultiLINX Target Interface Pin.

SelectMAP

SelectMAP mode is a configuration mode supported by the Spartan-II, Virtex, Virtex-II, and Virtex-II Pro device families.

Slave Serial

Slave Serial mode is a configuration mode supported by Virtex.

serial PROM

A PROM whose data is read serially, one bit at a time. The other PROM type is a byte wide PROM, which is read one byte at a time.

status bar

The field located at the bottom of the iMPACT window. It provides information about the commands that you are about to select or that are already being processed.

System ACE

System ACE is a Xilinx developed configuration environment that enables space-efficient, pre-engineered, high-density configuration solutions for systems with multiple FPGAs. There are two versions of System ACE: System ACE CF and System ACE MPM.

TCK pin

In iMPACT, the Boundary-Scan clock pin.

TDI pin

In iMPACT, the Boundary-Scan data pin.

TEKHEX (Tektronix)

A Tektronix PROM format supported by Xilinx. Its maximum address is 65,536. This format supports PROM files of up to $(8 \times 65,536) = 524,288$ bits.

TMS pin

In iMPACT, the Boundary-Scan select pin.

toolbar

A field located under the menu bar at the top of the main window. It contains a series of buttons that execute some of the most frequently

used commands. These buttons constitute an alternative to the menu commands.

TRIG pin

The external trigger pin of the MultiLINX Cable. This pin is connected to an external signal used as a trigger. A Low to High transition on this pin signals the cables to initiate a readback.

Vcc pin

Power pin of the configuration cable. This pin connects to the power pin of a target board.

verification

The process of reading back the configuration data and comparing it to the original downloaded design to ensure that all of the design was received by the device.

WS pin

The WS pin is a MultiLINX Target Interface Pin.

Boundary-Scan Basics

This appendix contains the following sections.

- [“Boundary-Scan/IEEE Standard 1149.1”](#)
- [“Configuring the Parallel Download Cable”](#)

Boundary-Scan/IEEE Standard 1149.1

Design complexity, difficulty of loaded board testing, and the limited pin access of surface mount technology led industry leaders to seek accord on a standard to support the solution of these problems.

JTAG Boundary-Scan, formally known as IEEE Standard 1149.1, is primarily a testing standard created to alleviate the growing cost of designing and producing digital systems. The primary benefit of the standard is the ability to transform extremely difficult printed circuit board testing problems (that could only be attacked with ad-hoc testing methods) into well-structured problems that software can handle easily and swiftly.

The standard defines a hardware architecture and the mechanisms for its use to solve the aforementioned problems.

What can it be used for?

Although primarily a testing standard for on-chip circuitry, the proliferation of the standard has opened the door to a wide variety of applications. The standard itself defines instructions that can be used to perform functional and interconnect tests as well as built-in self test procedures.

Vendor-specific extensions to the standard have been developed to allow execution of maintenance and diagnostic applications as well

as programming algorithms for reconfigurable parts. It is the latter that have been implemented (in addition to all the mandatory operations of the standard and some optional ones) in the FastFLASH family.

How does it work?

The top level schematic of the test logic defined by IEEE Std 1149.1 includes three key blocks:

The TAP Controller

This responds to the control sequences supplied through the test access port (TAP) and generates the clock and control signals required for correct operation of the other circuit blocks.

The Instruction Register

This shift register-based circuit is serially loaded with the instruction that selects an operation to be performed.

The Data Registers

These are a bank of shift register based circuits. The stimuli required by an operation are serially loaded into the data registers selected by the current instruction. Following execution of the operation, results can be shifted out for examination.

Impact Test Access Port

The JTAG Test Access Port (TAP) contains four pins that drive the circuit blocks and control the operations specified. The TAP facilitates the serial loading and unloading of instructions and data. The four pins of the TAP are: TMS, TCK, TDI and TDO. The function of each TAP pin is as follows:

TCK - this pin is the JTAG test clock. It sequences the TAP controller as well as all of the JTAG registers provided in the XC95108.

TMS - this pin is the mode input signal to the TAP Controller. The TAP controller is a 16-state FSM that provides the control logic for JTAG. The state of TMS at the rising edge of TCK determines the sequence of states for the TAP controller. TMS has an internal pull-up resistor on it to provide a logic 1 to the system if the pin is not driven.

TDI -this pin is the serial data input to all JTAG instruction and data registers. The state of the TAP controller as well as the particular instruction held in the instruction register determines which register is fed by TDI for a specific operation. TDI has an internal pull-up resistor on it to provide a logic 1 to the system if the pin is not driven. TDI is sampled into the JTAG registers on the rising edge of TCK.

TDO - this pin is the serial data output for all JTAG instruction and data registers. The state of the TAP controller as well as the particular instruction held in the instruction register determines which register feeds TDO for a specific operation. Only one register (instruction or data) is allowed to be the active connection between TDI and TDO for any given operation. TDO changes state on the falling edge of TCK and is only active during the shifting of data through the device. This pin is three-stated at all other times.

JTAG TAP Controller

The JTAG TAP Controller is a 16-state finite state machine, that controls the scanning of data into the various registers of the JTAG architecture. The state of the TMS pin at the rising edge of TCK is responsible for determining the sequence of state transitions. There are two state transition paths for scanning the signal at TDI into the device, one for shifting in an instruction to the instruction register and one for shifting data into the active data register as determined by the current instruction.

JTAG TAP Controller States

Test-Logic-Reset. This state is entered on power-up of the device whenever at least five clocks of TCK occur with TMS held high. Entry into this state resets all JTAG logic to a state such that it does not interfere with the normal component logic, and causes the IDCODE instruction to be forced into the instruction register.

Run-Test-Idle. This state enables certain operations to occur depending on the current instruction. For the XC9500/XL/XV family, this state causes generation of the program, verify and erase pulses when the associated in-system programming (ISP) instruction is active.

Select-DR-Scan. This is a temporary state entered prior to performing a scan operation on a data register or in passing to the Select-IR-Scan state.

Select-IR-Scan. This is a temporary state entered prior to performing a scan operation on the instruction register or in returning to the Test-Logic-Reset state.

Capture-DR. This state enables data to be loaded from parallel inputs into the data register selected by the current instruction on the rising edge of TCK. If the selected data register does not have parallel inputs, the register retains its state.

Shift-DR. This state shifts the data, in the currently selected register, towards TDO by one stage on each rising edge of TCK after entering this state.

Exit1-DR. This is a temporary state that enables the option of passing on to the Pause-DR state or transitioning directly to the Update-DR state.

Pause-DR. This is a wait state that enables shifting of data to be temporarily halted.

Exit2-DR. This is a temporary state that enables the option of passing on to the Update-DR state or returning to the Shift-DR state to continue shifting in data.

Update-DR. This state causes the data contained in the currently selected data register to be loaded into a latched parallel output (for registers that have such a latch) on the falling edge of TCK after entering this state. The parallel latch prevents changes at the parallel output of these registers from occurring during the shifting process.

Capture-IR. This state enables data to be loaded from parallel inputs into the instruction register on the rising edge of TCK. The least two significant bits of the parallel inputs must have the value 01 as defined by IEEE Std. 1149.1, and the remaining 6 bits are either hard-coded or used for monitoring of the security and data protect bits.

Shift-IR. This state shifts the values in the instruction register towards TDO by one stage on each rising edge of TCK after entering this state.

Exit1-IR. This is a temporary state that enables the option of passing on to the Pause-IR state or transitioning directly to the Update-IR state.

Pause-IR. This is a wait state that enables shifting of the instruction to be temporarily halted.

Exit2-IR. This is a temporary state that enables the option of passing on to the Update-IR state or returning to the Shift-IR state to continue shifting in data.

Update-IR. This state causes the values contained in the instruction register to be loaded into a latched parallel output on the falling edge of TCK after entering this state. The parallel latch prevents changes at the parallel output of the instruction register from occurring during the shifting process.

Mandatory Boundary-Scan Instructions

BYPASS. The BYPASS instruction enables rapid movement of data to and from other components on a board that are required to perform test operations.

SAMPLE/PRELOAD. The SAMPLE/PRELOAD instruction enables a snapshot of the normal operation of a component to be taken and examined. It enables data values to be loaded onto the latched parallel outputs of the Boundary-Scan shift register prior to the selection of other Boundary-Scan test instructions.

EXTEST. The EXTEST instruction enables testing of off-chip circuitry and board level interconnections.

Optional Boundary-Scan Instructions

INTEST. The INTEST instruction enables testing of the on-chip system logic while the components are already on the board.

HIGHZ. The HIGHZ instruction forces all drivers into high impedance states.

IDCODE. The IDCODE instruction enables blind interrogation of the components assembled onto a printed circuit board to determine what components exist in a product.

USERCODE. The USERCODE instruction enables a user-programmable identification code to be shifted out for examination. This enables the programmed function of the component to be determined.

Configuring the Parallel Download Cable

To configure your parallel download cable, follow these steps:

1. On PCs you can connect the parallel cable to your system's parallel printer port. The iMPACT Configuration software automatically identifies the cable when correctly connected to your PC. If you choose to, you may also select this connection manually. To set up a parallel port manually:

Output →Cable Setup

Select the Parallel button and match to the port you are using, then click on OK.

Appendix B

Parallel Cable III (DLC 5) Schematic

This appendix contains a schematic of the Parallel Download Cable III. It is included if you want to build your own download cables. Schematic, Figure B-1, is our current version of the Parallel Download Cable III. If you want to build a parallel cable, this is the recommended schematic.

Note You must use recommended lengths for parallel cables. Xilinx cables are typically six feet (about two meters) in length.

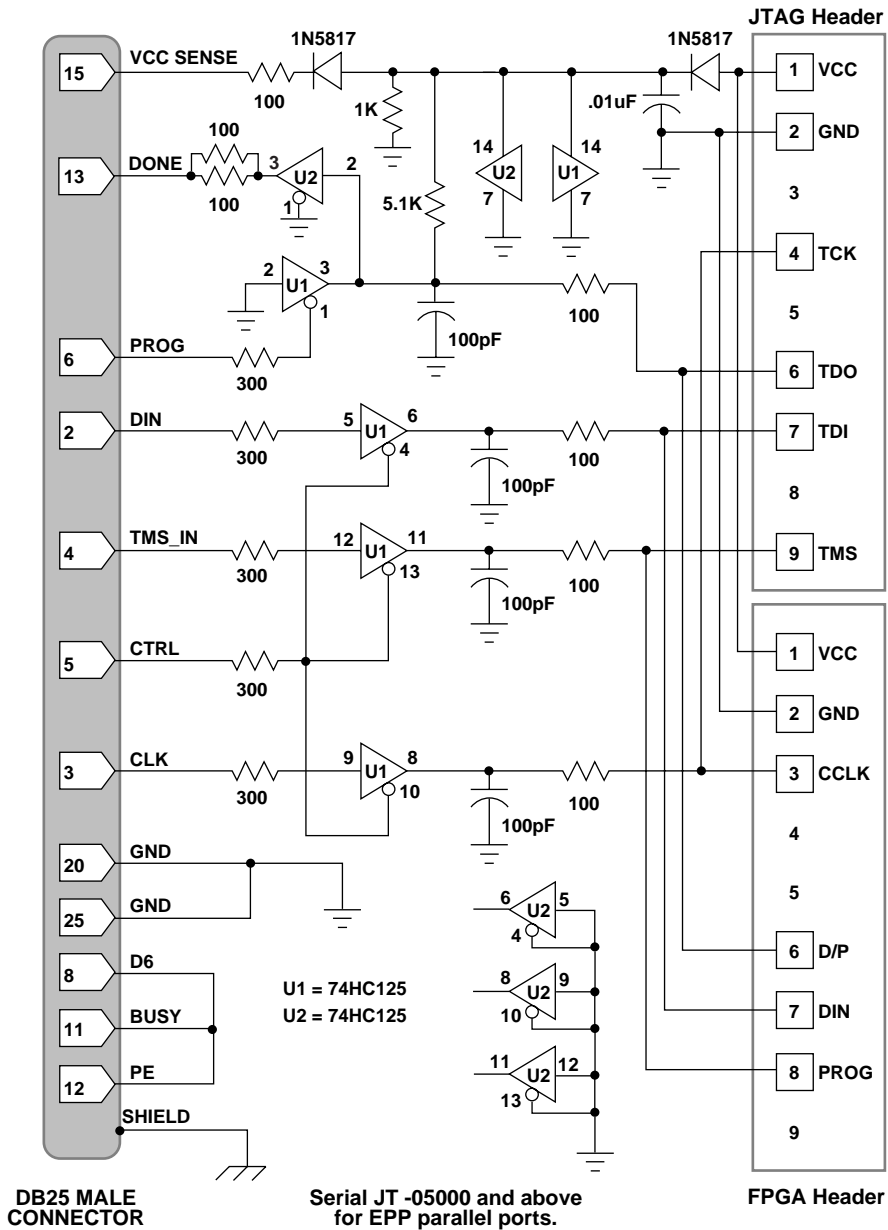

Figure B-1 Parallel Download Cable III

Command Line and Batch Mode Commands

This appendix contains the following sections.

- [“Difference Between Command Line and Batch Mode Operation”](#)
- [“Command Line Usage”](#)
- [“Command Line Options”](#)
- [“Batch Mode Commands”](#)
- [“Configuration Mode Commands”](#)
- [“File Generation Mode Commands”](#)
- [“Example Batch Mode Command Sequences”](#)
- [“JTAGPROG to iMPACT Script Migration”](#)

Difference Between Command Line and Batch Mode Operation

The iMPACT command line serves as a method to launch the iMPACT GUI in a specific place. To launch the iMPACT GUI from the command line, type **impact**. However, operations such as Program, Erase, etc., cannot be specified on the command line. To perform operations, Batch mode must be used.

Batch mode is an interactive mode where you type in commands at a command prompt. Batch mode can also receive command files (.cmd) and performs the commands contained in the file as if they were coming from the command prompt. To enter iMPACT Batch mode, type **impact -batch**. If you want to pass a command file, refer to the [“Command Line Usage”](#) section.

Command Line Usage

`impact`[-Switch Parameter] [-Switch Parameter]

Command Line Options

When an option occurs without parentheses "(" next to the command name in the syntax, it is required. When it appears in square brackets "[]," it is optional.

When two or more options occur between braces "{}," the options must be entered with the command. If the options are separated by a vertical bar "|," you must choose one of the possible parameters. If one term is divided into a subset of parameters that can be entered separately or together, each subparameter occurs between square brackets.

Table C-1 Command Line Options

| Switch | Parameter(s) | Notes |
|------------------|--|--|
| -j or -jedec | jedec file name (.jed extension) | If a full path is not given, the specified file is assumed to reside in the current working directory. |
| -b or -bitstream | bitstream file name (.bit extension) | If a full path is not given, the specified file is assumed to reside in the current working directory. |
| -p or -prom | mcs, exo or hex file name (.exo, .mcs, .hex extensions respectively) | If a full path is not given, the specified file is assumed to reside in the current working directory. |
| -c or -cdf | cdf file name (.cdf extension) | If a full path is not given, the specified file is assumed to reside in the current working directory. |

Table C-1 Command Line Options

| Switch | Parameter(s) | Notes |
|--------|--|--|
| -port | PC: auto,lpt1,lpt2,lpt3,com1, com2,com3,usb0,usb1, usb2 UNIX: auto,/dev/ttya,/dev/ttyb /dev/tty00 dev/tty01 | "auto" means automatically detect cable available and connect to it. If the -port switch is not specified, the application does not attempt cable connection at start-up |
| -batch | .cmd file | initiates batch mode |
| -mode | bscan,sserial,smap,dtconfig, cf,mpm,bsfile,pff | Indicates the mode in which to start the application. The default mode is Boundary-Scan (bscan) |
| -baud | auto,9600,19200,38400,5760 0 | When the "-port" switch is used to select a serial port connection (com1,com2,com3,/dev/ttya,/dev/ttyb) this switch indicates the connection speed (baud rate). "auto" indicates that the speed selection should automatically choose the fastest possible. The default "-baud" value is "auto". |

Batch Mode Commands

Common flags and their meanings:

Note Any line beginning with a # will be treated as a comment.

-cs 0|1|2: Refers to chip selects in SelectMAP mode.
There are three chip selects on the MultiLINX cable.

-p|-position: Refers to the position of the device in the chain.

-f | -file: Filename.

-size: Size of the storage device in bytes.

Batch Mode Definitions

Below are the definitions of each of the iMPACT command line switches available.

Table C-2 Command Line Definitions

| System ACE Command Line Options | Switch Name | Switch Description |
|---------------------------------|-------------|--|
| setMode | -cf | Sets the mode for the System ACE CF. |
| | -mpm | Sets the mode for the System ACE MPM. |
| addConfigDevice | -size | Defines the size of the CompactFlash device. A value of '0' in this switch signifies the size is unlimited. With this value set to '0' the user will not be warned when they exceed the CompactFlash device size capability. |
| | -name | Used to label the target CompactFlash device or Microdrive. |
| | -path | Specifies the project location. |
| addCollection | -name | Specifies the name for each collection. |
| addDesign | -name | Specifies the name for each design added. |
| | -version | Labels each version, associated with the eight active design locations represented by the external pin settings of CFGAddr [0:2]. |
| addDeviceChain | -index | For the System ACE CF this switch is a place holder; a chain definition initializer. |

Table C-2 Command Line Definitions

| System ACE Command Line Options | Switch Name | Switch Description |
|---------------------------------|-----------------|---|
| addDevice | -p -file | Specifies the chain location for each device. The device locations begin with 0. Switch used to assign a configuration bitstream to the device in the JTAG chain selected. |
| generate | -active | Specifies the active collection that will be written to the xilinx.sys file. |

Example: Below is an example using iMPACT 4.2i to target the System ACE CF Solution.

After sp3, this is the way it will work:

```

impact -batch
setMode -cf
addConfigDevice -size 0 -name <devicename> -path
c:\<path_for_project>
addCollection -name <collection_name>
addDesign -version 0 -name <design_name>
addDeviceChain -index 0
addDevice -p 1 -file c:\<path_to_design\design.bit>
generate -active <collection_name>
quit
    
```

General Commands

savecdf -f|-file <file name> : create .cdf file from device database

loadcdf -f|-file <file name> : load cdf file and initialize device database from its contents

deleteDevice [-p|-position <pos1>...<posN>] [-all]
: delete a specified device

-all takes no argument and removes all devices from iMPACT's memory.

```
setMode [-ss|-sserial|-sm|-smap|-bs|-bscan|-mpm|-cf|-compactflash|-pff|-promfile|-bsfile|-dtconfig]
```

-ss|-sserial :switches you to the Slave Serial Configuration mode

-sm|-smap :switches to the SelectMAP Configuration mode

-bs|-bscan :switches to the Boundary-Scan Configuration mode

-mpm :switches to the System ACE MPM File Generation mode

-cf|-compactflash :switches to the System ACE CF File Generation mode

-pff|-promfile :switches to the PROM File Generation mode

-bsfile :switches to the Boundary-Scan File Generation mode (SVF/STAPL)

-dtconfig :switches to the Desktop Configuration mode, where you can access the Xilinx MultiPRO cable, and program non-volatile devices

```
assignFile [-p|-position <posN>] [-f|-file|<filename>] :Assigns/changes file to previously defined device.
```

exit|quit :Exits the program.

info :displays table of device database (position:device type:file name)

Configuration Mode Commands

Because JTAG file formats like SVF and STAPL are essentially programming "batch" files, these configuration mode commands are used when creating these types of files.

General Configuration Mode Commands

```
setCable [-p|-port  
lpt1|lpt2|lpt3|com1|com2|com3|com4|  
usb0|usb1|usb2|tty|ttyp|svf|stapl|auto] [-b|-baud  
9600|19200|38400|57600] [-f|-file <filename>]
```

-p |-port :Select port.

-auto :detects first available cable (order of detection: usb, parallel, serial).

svf and **stapl** :selects file output.

-baud :applicable to serial port connections only.

-f | **-file** :refers to the svf or stapl file to use.

setPreference [-concurrent | -con | -sequential | -seq] [-expert | -exp | -novice | -nov] [-bypass | -bp | -highz | -hz]:Sets preferences found in the Edit->Preferences dialog.

[-concurrent | -con | -sequential | -seq] :Sets programming mode for CPLD devices.

bypass | **highz** :indicates which instruction to use on bypassed devices in JTAG (default is bypass).

Expert | **e** | **novice** | **n** :refers to the messaging mode.

Note Setting defaults to -concurrent, -bypass, -novice, .

addDevice [-p | -position <pos>] [-sprom | -mpm xc18v256 | xc18v512 | xc18v01 | xc18v02 | xc18v04 | xccacem16 | xccacem32 | xccacem64 | xccacem128] [-cs 0 | 1 | 2] [file<filename>]:Adds a device to the chain in the position specified.

Note If the device is a serial PROM or System ACE MPM/SC device, the **-sprom** or **-mpm** flag must be used, and the particular device specified.

program [-e | -erase] [-v | -verify] [-w | -writeProtect] [-r | -readProtect] [-u | -usercode | -ues <codeString>] [-t | -functest] [-parallel] [-cascadeLowPower] [-noncascadeLowPower] [-skipua] [-useD4] [-loadfpga] [-s | -secureMode] [-keyonly] [-key {<keyfile>}] [-p | -position <pos1> {<pos2>}]

-cs (chip select) is used in SelectMap mode.

-f (file) overwrites default file name specified in addDevice command and can only be used when only one device is specified.

pos1 , , , *posN* specifies a group of devices to operate on.

-u | **usercode** | **ues** stands for User Electronic Signature.

-parallel enables the parallel outputs on an XC18Vxx PROM

-skipua skips the user array for a PROM. This would be used in cases where the user does not wish to program the main PROM array, but instead wants to program just a user code, etc.

-useD4 causes the D4 pin of an XC18Vxx PROM to be used as a Chip Select, when in parallel mode.

-loadfpga issues the “load FPGA” instruction to the XC18Vxx PROM, which causes it to automatically program the FPGA.

-closeCable closes the open cable and forces a detection the next time a cable operation is executed.

verify [-p|-position <pos1>...<posN>] [-cs 0|1|2] [-f|-file <filename>] :Reads configuration information back from a programmed device, and compares it to the file specified.

Note Boundary-Scan and SelectMAP modes only.

Boundary-Scan Mode Specific Commands

erase [-p|-position <pos1>...<posN>] :Erases the device(s) at the specified position(s).

blankCheck [-p|-position <pos1>...<posN>] :Checks to see if the device(s) at the specified position(s) are not programmed.

readIdcode [-p|-position <pos1>...<posN>][-loop <loopCount>] :Reads the ID Codes of the device(s) at the specified position(s).

readUserCode [-p|-position <pos1>...<posN>][-u|-usercode <usercode>] :Reads the User Codes of the device(s) at the specified position(s).

readUES [-p|-position <pos1>...<posN>] :Reads the User Electronic Signature of the device(s) at the specified position(s).

programUES [-p|-position <pos1>...<posN>] :Programs the User Electronic Signature of the devices at the specified position(s).

readbackToFile [-p|-position <pos1>...<posN>] [-f|-file <filename>] :Reads the programming information of the device(s) at the specified position(s) into a file.

checksum [-p|-position <pos1>...<posN>] :Calculates the checksum of the device(s) at the specified position(s).

bypass [-p|-position <pos1>...<posN>] :Places the device(s) at the specified position(s) into bypass.

bsdebug [-start] [-reset] [-stop] [-tms 0|1] [-tdi 0|1] [-tck <number>] [-loop <number>] :Executes the Boundary-Scan Debug instruction which shifts in the instruction and data values specified by -tms and -tdi.

identify :Displays table of device types resulting from "initialize chain" operation.

File Generation Mode Commands

setsubMode [-mpmss|-mpmsm|-pffserial|-pffparallel]

(Some of the modes of iMPACT have sub-modes.)

-mpmss :switches you to the Slave Serial sub-mode of MPM File Generation mode.

-mpmsm :switches you to the SelectMAP sub-mode of MPM File Generation mode.

-pffserial :switches you to the Slave Serial sub-mode of PROM File Generation mode.

-pffparallel :switches you to the Parellel sub-mode of PROM File Generation mode.

generate [-active <collectionName>] [-path <pathString>] [-output <outputFile>] [-compressed] [-format mcs|exo|hex|tek] [-fillvalue <hexByte>] [-disableswap] [-generic]:Generates the file appropriate for the current mode.

-active :sets the active collection name for System ACE CF.

-compressed :turns on bitstream compression for System ACE MPM mode.

-format :sets the file format for PROM Formatter .

-fillvalue :sets the value to fill the leftover portion of a PROM with. Specified as a hex byte, e.g. "FF" or "00".

-disableswap :turns off the automatic bitswapping.

-generic :tells PROM Formatter that the target device is a generic (non-Xilinx) PROM. Size restrictions are not compared, in these cases.

PROM Formatter Specific Commands

addPromDevice [-p|-position <pos>] [-size <size>] [-name <name>] :Adds a PROM to PROM Formatter File Mode.

loadPdr [-file <fileName>]:Load PROM Description file (file created from PROM Formatter).

setPromOptionBits [-p|-position <pos1> {<pos2>}][-u|-usercode <usercode>][-parallel][-cascadeLowPower] [-noncascadeLowPower][-useD4] [-loadfpga]

-parallel enables the parallel outputs on an 18Vxx PROM.

-useD4 causes the D4 pin of an XC18Vxx PROM to be used as a Chip Select, when in parallel mode.

-loadfpga sets a flag in the XC18Vxx PROM which causes it to automatically load the FPGA once the PROM has been programmed.

System ACE Specific Commands

addCollection [-name <name>]:Adds a System ACE CF collection to System ACE CF.

addDesign [-version <versionNumber>] [-name|-designName|startaddress <designName>] [-collection|-c <collectionName>] [-d|-down]:Adds a design to System ACE CF and MPM File Generation Modes.

addConfigDevice [-size <size>] [-name <name>][-path <path>] :Adds a System ACE configuration device to System ACE File Generation Mode.

addDeviceChain [-index|-csPin] [-d|-design|startaddress <design>] [-c|-collection <collectionName>]:Adds a Slave Serial device chain to System ACE MPM Slave Serial File Generation Mode.

Example Batch Mode Command Sequences

iMPACT's batch mode can be used either interactively, by typing commands at a prompt (>), or in true batch mode by passing it a command (.cmd) file at the command line (impact -batch filename.cmd).

There is a certain order in which commands must be issued. For example, you cannot program a part unless you first set the mode, issue the command to select the cable, and have defined a chain of at least one device.

You often need to perform six operations in your command (.cmd) file:

1. Set the configuration mode
2. Set up the cable port
3. Define the JTAG chain and assign files
4. Program the device
5. Verify the device
6. Exit from the programming software

General Batch Command Sequence Format

Below is a list of the most commonly used commands and options.

```
setmode -bscan
setcable -p auto
identify (optional)
addDevice -p [device number] -file [filename.bit/
.jed]
addDevice -p [device number] -sprom [part name] -file
[filename.mcs/.exo]
program -p [device number]-verify
saveCdf -file [filename]
loadCdf -file [filename]
quit (or exit)
```

Command Sequence Example 1: Creating a Chain Using addDevice

```
setMode -bs
setCable -p auto
addDevice -p 1 -file bitstream1.bit
addDevice -p 2 -file bitstream2.bit
```

```
program -v -p 2  
quit
```

The preceding example creates a chain of two devices, then programs and verifies the second device in the chain and exits the program. The exit command ends batch mode and causes an exit to the command prompt.

Command Sequence Example 2: Chain Consisting of: XC18V04 (programmed), Third Party Device (bypassed) XC18v04 (programmed), XC18V04 (bypassed with .bsd file)

```
setmode -bscan
setcable -p auto
addDevice -p 1 -sprom xc18v04 -file design1.mcs
addDevice -p 2 -file thirdparty.bsd
addDevice -p 3 -sprom xc18v04 -file design2.mcs
addDevice -p 4 -file xc18v04_vq44.bsd
program -e -v -p 1
program -e -v -p 3
quit
```

Notice how the PROM devices require the use of the `-sprom` switch in the `addDevice` command. In this example, only the two PROMs are programmed and the other devices in the chain are placed in bypass. Use of the `-e` (erase) option is strongly recommended for PROM devices. XC18v00 devices can be damaged if they are not erased before programming. The `-v` (verify) option tells iMPACT to verify the device after programming.

Command Sequence Example 3: Using JTAG to Automatically Identify a Chain

```
setMode -bs
setCable -p auto
identify
assignFile -p 1 -file bitstream1.bit
assignFile -p 2 -file bitstream2.bit
saveCdf -file batch.cdf
program -v -p 2
quit
```

The `identify` command is equivalent to the `initialize chain` command, in the GUI. The `identify` command displays text that lists each device in the chain give a number for its order. Then, files can be

assigned and the desired device programmed. Notice also that a Chain Description File (.cdf) is created for future use.

Command Sequence Example 4: Loading a .cdf File and Programming a Device

```
setMode -bs
setCable -p auto
loadCdf -file batch.cdf
program -p 2
quit
```

The loadCdf command loads an existing chain description into iMPACT. All file associations are contained in the .cdf file, so the device can immediately be programmed.

JTAGPROG to iMPACT Script Migration

This section is provided as a guide to help customers convert their 3.1i JTAGPROG .cmd script files for use with 4.1i iMPACT.

Getting Started

JTAGPROG and iMPACT are both case-insensitive. Uppercase syntax is used in this and other documents for the sake of clarity.

To invoke JTAGPROG in batch mode:

```
jtagprog -batch bat_file.cmd
```

To invoke iMPACT in batch mode:

```
impact -batch bat_file.cmd
```

The .cmd file is simply a text file which specifies the instructions to be performed in batch mode. All instructions that follow should be placed in this .cmd file.

Determining the Part Name

JTAGPROG and iMPACT both require the user to specify a part name for certain commands. This can cause confusion, as the required naming convention is not provided in the documentation for JTAGPROG or iMPACT.

When specifying the part name with the part command, the part name must exactly match the name of the BSDL file that is associated with that part, minus the file extension (examples provided in table C-2). BSDL files for all parts can be found in the \$xilinx folder.

This applies to both JTAGPROG and iMPACT.

Note

Table C-3

| Device | JTAGPROG/iMPACT Part Name | BSDL File Location |
|------------------|---------------------------|--|
| 18v04 pc44 | xc18v04_pc44 | \$xilinx\xc1800\data\xc18v04_pc44.bsd |
| 95144XL cs144 | xc95144xl_cs144 | \$xilinx\xc9500xl\data\xc95144xl_cs144 |
| Virtex 100 pq240 | xcv100_pq240 | \$xilinx\virtex\data\xcv100_pq240.bsd |

Programming and Verifying a Device

You often need to perform five operations in your command (.cmd) file:

1. Set up the cable port.
2. Define the JTAG chain and assign files.
3. Program the device.
4. Verify the device.
5. Exit from batch mode.

JTAGPROG

Autoconfigure

```
part part_type:[arbitrary part name]
```

```
program [arbitrary part name] -f [filename.bit/.jed/.mcs]
```

```
verify [arbitrary part name]
```

```
quit
```

iMPACT

```
setmode -bscan
setcable -p auto
identify (optional)
addDevice -p [devicenumber] -file [filename.bit/.jed]
program - verify -p [device number]
quit
```

iMPACT (XC18V00 Family)

The iMPACT syntax varies slightly for 18v00 PROMs.

```
setmode -bscan
setcable -p auto
identify (optional)
addDevice -p [device number] -sprom [part name]3 -file
[filename.mcs/.exo]
program -e -v -p [device number]
quit
```

iMPACT (when assigning a BSDL file)

Again, the syntax is slightly different when assigning a BSDL file to a device. This situation arises whenever third-party devices are used or when BSDL files are used to bypass Xilinx devices.

```
setmode -bscan
setcable -p auto
identify (optional)
addDevice -p [device number] -file [filename.bsd]
assignFile3 -p [device number] -file [filename.bsd]
bypass -p [device number]4
quit
```

Note

[device number] = 1,2,3...

If the programming file does not reside in the working directory, the full path may be specified, e.g.: -file c:\test\filename.bit

[part name] = xc18v256, xc18v512, xc18v01, xc18v02, or xc18v04.

The bypass command is not needed in most cases, since devices with no action assigned are automatically placed in bypass. See the Examples, below.

Blank lines are not allowed in the iMPACT .cmd file.

Example: Programming a XC18v00 PROM

JTAGPROG

```
autoconfigure
part xc18v04_pc44:device1
program device1 -f c:\test\design.mcs
quit
```

iMPACT

```
setmode -bscan
setcable -p auto
identify
addDevice -p 1 -sprom xc18v04 -file design.mcs
program -p 1
quit
```

iMPACT (SVF mode)

```
setmode -bscan
setcable -p svf -file output.svf
addDevice -p 1 -sprom xc18v04 -file design.mcs
program -e -v -p 1
quit
```

Example: XC2v1000 Device (bypassed with a .bit file) in a Chain with an XC18v04 Device (programmed)

```
JTAGPROG
reset
autoconfigure
part xc2v1000_fg256:device1 xc18v04_pc44:device2
program device2 -f design.mcs
quit
```

iMPACT

```
setmode -bscan
setcable -p auto
identify
addDevice -p 1 -file design.bit
addDevice -p 2 -sprom xc18v04 -file design.mcs
program -e -v -p 2
quit
```

iMPACT (SVF mode)

```
setmode -bscan
setcable -p svf -file output.svf
addDevice -p 1 -file design.bit
addDevice -p 2 -sprom xc18v04 -file design.mcs
program -e -v -p 2
quit
```

Note No instruction is required to bypass the 2v1000. Devices that do not have instructions specified are bypassed automatically. Bypassed Xilinx devices can be assigned either a BSDL (.bsd) file or a programming file (.bit/.jed/.mcs/.exo). Bypassed third-party devices must be assigned a BSDL file.

Example: XC2v1000 (programmed) in a Chain with a XC18v04 (bypassed with a BSDL file)

JTAGPROG

```
reset
autoconfigure
part xc2v1000_fg256:device1 xc18v04_pc44:device2
program device1 -f design.bit
quit
```

iMPACT

```
setmode -bscan
setcable -p auto
identify
addDevice -p 1 -file design.bit
addDevice -p 2 -file xc18v04_pc44.bsd
assignFile -p 2 -file xc18v04_pc44.bsd
program -p 1
quit
```

iMPACT (SVF mode)

```
setmode -bscan
setcable -p svf -file output.svf
assignfile -p 1 -file design.bit
assignfile -p 2 -sprom xc18v04 -file design.mcs
program -p 1
quit
```

Example: Chain Consisting of XC18v04 (programmed), Third Party Device (bypassed), XC18v04 (programmed), XC18v04 (bypassed with a .bsd file)

JTAGPROG

```
reset
autoconfigure
part xc18v04_vq44:device1 thirdparty:device2
xc18v04_vq44:device3 xc18v04_vq44:device4
program device1 -f design.mcs
program device3 -f design.mcs
quit
```

iMPACT

```
setmode -bscan
setcable -p auto
identify
addDevice -p 1 -sprom xc18v04 -file design1.mcs
addDevice -p 2 -file thirdparty.bsd
assignFile -p 2 -file thirdparty.bsd
addDevice -p 3 -sprom xc18v04 -file design2.mcs
addDevice -p 4 -file xc18v04_vq44.bsd
assignFile -p 4 -file xc18v04_vq44.bsd
program -e -v -p 1
program -e -v -p 3
quit
```

iMPACT (SVF mode)

```
setmode -bscan
setcable -p svf -file output.svf
addDevice -p 1 -sprom xc18v04 -file design1.mcs
addDevice -p 2 -file thirdparty.bsd
assignFile -p 2 -file thirdparty.bsd
addDevice -p 3 -sprom xc18v04 -file design2.mcs
addDevice -p 4 -file xc18v04_vq44.bsd
assignFile -p 4 -file xc18v04_vq44.bsd
program -e -v -p 1
program -e -v -p 3
quit
```

