

MLB-G3002 Terminal User Guide



MLiS Basic Dual Band 2G/3G

Model Number:

MLB-G3002

Information provided by Schmidt & Co., (HK) Ltd, (herein known as 'the company'), is believed to be accurate and reliable. However, the company assumes no responsibility for its use, nor any infringement of patents or other rights of third parties, which may result from its use. No license is granted by implication or otherwise under any patent rights of the company other than for circuitry embodied in the company's products. The company reserves the right to change the circuitry and specifications at any time without notice. This document is subject to change without notice.

No part of this document may be reproduced or transmitted in any form or by any means, electronic or mechanical, including but not limited to photocopying, recording, transmitting via fax and/or modem devices, scanning, and/or information storage and retrieval systems for any purpose without the expressed written consent of the company.

WARNING: The MLiS GSM Terminal is a RF product intended for interfacing and operating with a host device. Local relevant RF regulations such as allowed frequencies and usage in commercial flights must be observed. Safety instructions must be included in the manuals of the host device. Schmidt & Co., (HK) Ltd assumes NO liability for customers, who fail to comply with these precautions.

Service and Support

TBA

Download Information

TBA

Revision History

Version	Date	Description
1.0	Nov 2013	1 st Release
1.1	Apr 2014	2 st New Command Operation

CONTENTS

1	INTRODUCTION	7
1.1	Description	7
1.2	Highlights	7
1.3	Functional Block diagram	9
1.4	Main Features and Services	10
1.4.1	Operating Modes	10
1.4.2	Terminal Features and Electrical Specifications	11
1.5	Precautions	12
2	MECHANICAL DESCRIPTION	13
2.1	Overview	13
2.2	Dimensions	13
3	ELECTRICAL INTERFACE DESCRIPTIONS	14
3.1	Overview	14
3.2	Radio Interface (Type SMA Connector Female) - RF Antenna	15
3.3	RJ45 Connector	16
3.4	SIM card holder	17
3.5	Extend I/O	18
4	OPERATING MODES	19
4.1	Power on the Modem	19
4.2	Power off the Modem	19
4.3	LED Status via LED	20
5	Command Operation	21
5.1	Command Operation for SMS	21
5.1.1	SMS Explanation	22
5.2	Command Operation for Socket mode	25

5.2.1	Command Operation for Transparent Socket mode.....	26
5.3	Command Operation for FTP mode.....	27
5.4	Command Operation for HTTP mode	31
5.5	Command Operation for SMTP mode	35
5.6	Command Explanation	37
5.6.1	AT^SICS Internet Connection Setup Profile.....	37
5.6.2	AT^SISS Internet Service Setup.....	39
5.6.3	AT^SISO Internet Service Open	49
5.6.4	AT^SIST Enter Transparent Access Mode	49
5.6.5	+++ Switch from data mode to command mode.....	49
5.6.6	AT^SISC Internet Service Close	49
5.6.7	AT^SISW Internet Service Write Data.....	50
5.6.8	AT^SISR Internet Service Read Data	53
6	SALES CONTACT.....	55
7	ORDERING INFORMATION.....	56

List of Figures

Figure 1: Functional Block Diagram for MLB-G3002	9
Figure 2: Chassis Dimension for MLB-G3002	13
Figure 3: External Interfaces/Indicators for MLB-G3002.....	14
Figure 4: Antenna Connector for MLB-G3002.....	15
Figure 5: RJ45 Connector Pin Definition for MLB-G3002	16
Figure 6: SIM Card Holder for MLB-G3002	17

List of Tables

Table 1: Operating Modes	10
Table 2: Features and Specifications	12
Table 3: Chassis Dimensions and Mechanical Description for MLB-G3002	13
Table 4: Interfaces and Indicators Description of MLB-G3002	15
Table 5: RJ45 connector configuration for MLB-G3002.....	16
Table 6: Applicability of AT^SICS <conParmTag> values	38
Table 7: Applicability of AT^SISS <srvParmTag> values	47

1 INTRODUCTION

1.1 Description

The MLiS MLB-G3002 Dual Band 2G/3G terminal is a compact terminal that is designed for wireless M2M communications.

The MLiS MLB-G3002 terminal uses the RJ45 Connector to provide power and data communication interface.

- MLB-G3002 is a Dual Band 2G/3G terminal, supports Java platform.

The MLB-G3002 terminal can be used to provide a wireless communication link to many applications, including metering, fleet and asset management, vending, security and alarm monitoring, e-maintenance and other telemetry applications.

1.2 Highlights

Interface

- RJ45 Connector (Power and Communications)
- SMA Female Connector (GSM antenna connector)
- SIM card reader
- USB 2.0
- 12 * I/O pins

General Features

- Dual / Quad-Band GSM 850/900/1800/1900 MHz
- GPRS multi-slot class 8
- GSM release 99
- Output Power
 - Class 4 (+33dBm \pm 2dB) for EGSM850 (quad band only)
 - Class 4 (+33dBm \pm 2dB) for EGSM900
 - Class 1 (+30dBm \pm 2dB) for GSM1800
 - Class 1 (+30dBm \pm 2dB) for GSM1900 (quad band only)
- Control via AT commands
- SIM Application Toolkit (release 99)
- TCP/IP stack access via AT commands
- Internet Services: TCP, UDP, HTTP, FTP, SMTP

-
- Supply voltage range: 5 to 32 VDC
 - Temperature range
 - Operating: -30°C to 85°C
 - Restricted operating: 65°C to 80°C
 - Dimensions (L) x (W) x (H) = 93.33 mm x 73.86 mm x 20.00 mm (excluding connectors)
 - Weight: 90g

GPRS Data Transmission

- GPRS Class 12: max. 86kbps (DL & UL)
- Mobile station class B
- PBCCH support
- Coding schemes CS 1-4

CSD Data Transmission

- Up to 14.4kbit/s
- V.110, RLP
- Non transparent
- USSD support

PPP-stack for GPRS data transfer

Short Message Service (SMS)

- Point-to-point MO and MT
- SMS cell broadcast
- Text and PDU mode
- Cell broadcast
- Storage: SIM card plus 25 SMS locations in mobile equipment Transmission of SMS alternatively over CSD or GPRS. Preferred mode can be user defined.

1.3 Functional Block diagram

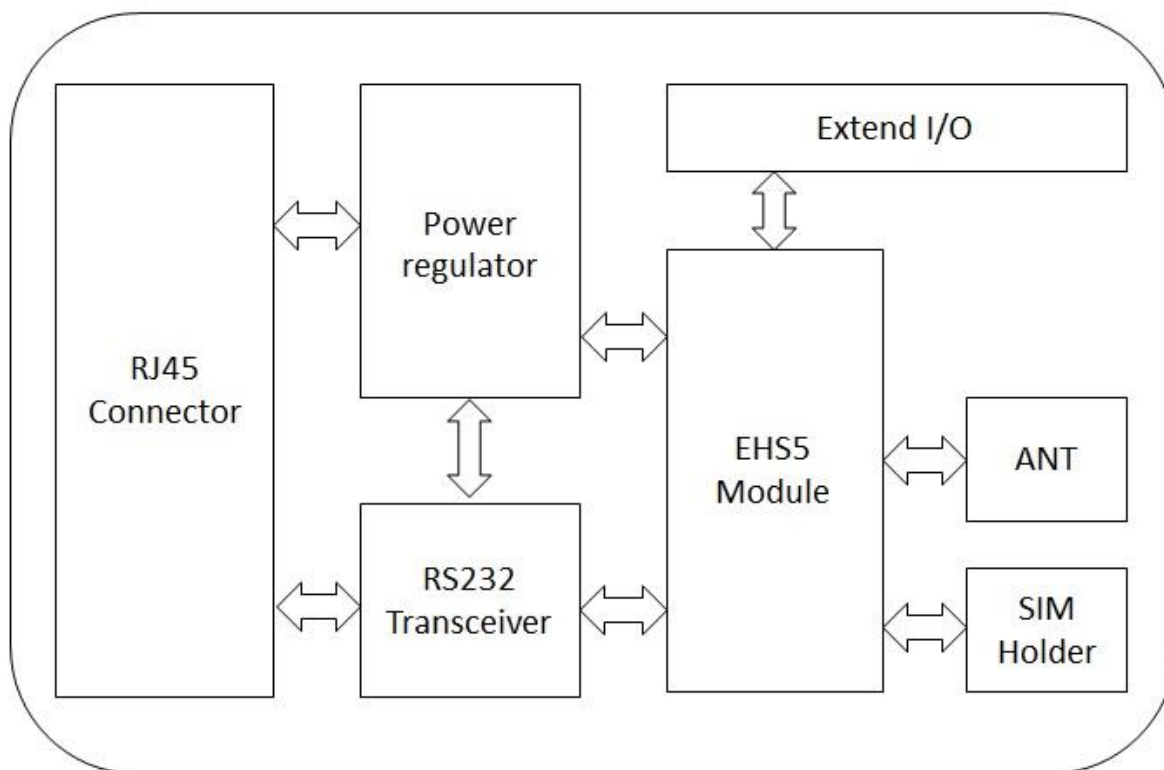

Figure 1: Functional Block Diagram for MLB-G3002

The MLB-G3002 consists of a fully certified (CE approved) GSM/GPRS engine, SIM card holder and power regulator.

The terminal is supplied with power via the RJ45 connector. The remaining RJ45 connector pins are used for data communications.

The SMA female connector provides the air interface to an external 50 ohm antenna specified for the correct frequency band.

1.4 Main Features and Services

The MLB-G3002 performs a set of telecom services (TS) according to GSM standard phase 2+, ETSI and ITU-T. The services and functions of the MLB-G3002 are implemented by issuing customized applications embedded on the device, or by AT commands issued internally, or over the RJ45 to RS232 serial interface.

1.4.1 Operating Modes

The table below briefly summarizes the various operating modes referred to in the following chapters.

Normal operation	GSM / GPRS SLEEP	Various power save modes set with AT+CFUN command. Software is active to minimum extent. If the module was registered to the GSM network in IDLE mode, it is registered and paging with the BTS in SLEEP mode, too. Power saving can be chosen at different levels: The NON-CYCLIC SLEEP mode (AT+CFUN=0) disables the AT interface. The CYCLIC SLEEP modes AT+CFUN=7 and 9 alternately activate and deactivate the AT interfaces to allow permanent access to all AT commands.
	GSM IDLE	Software is active. Once registered to the GSM network, paging with BTS is carried out. The module is ready to send and receive.
	GPRS IDLE	Module is ready for GPRS data transfer, but no data is currently sent or received. Power consumption depends on network settings and GPRS configuration (e.g. multislot settings).
	GPRS DATA	GPRS data transfer in progress. Power consumption depends on network settings (e.g. power control level), uplink / downlink data rates, GPRS configuration (e.g. used multislot settings) and reduction of maximum output power.
POWER DOWN	Normal shutdown after sending the AT^SMSO command. Only a voltage regulator is active for powering the RTC. Software is not active. Interfaces are not accessible. Operating voltage (connected to BATT+) remains applied.	
Airplane mode	<p>Airplane mode shuts down the radio part of the module, causes the module to log off from the GSM/GPRS network and disables all AT commands whose execution requires a radio connection. Airplane mode can be controlled by using the AT commands AT^SCFG and AT+CALA:</p> <ul style="list-style-type: none"> • With AT^SCFG=MEopMode/Airplane/OnStart the module can be configured to enter the Airplane mode each time when switched on or reset. • The parameter AT^SCFG=MEopMode/Airplane can be used to switch back and forth between Normal mode and Airplane mode any time during operation. • Setting an alarm time with AT+CALA followed by AT^SMSO wakes the module up into Airplane mode at the scheduled time. 	

Table 1: Operating Modes

1.4.2 Terminal Features and Electrical Specifications

S/N	Feature	Specifications	
1	Frequency Bands	EU GSM/GPRS/EDGE: 900/1800MHz and UMTS/HSPA+: 900/2100MHz US GSM/GPRS/EDGE: 850/1900MHz and UMTS/HSPA+: 850/1900MHz	
2	RF Output Power	Class 4 (+33dBm \pm 2dB) for EGSM850 (quad band only) Class 4 (+33dBm \pm 2dB) for EGSM900 Class 1 (+30dBm \pm 2dB) for GSM1800 Class 1 (+30dBm \pm 2dB) for GSM1900 (quad band only)	
3	GSM Phase	Release 99	
4	Power Supply	5 to 32 VDC	
5	Power Consumption	- DATA mode : GPRS 1TX, 4RX GSM 850/EGSM 900 GSM 1800/1900	180mA 145mA
		- DATA mode : GPRS 2TX, 3RX GSM 850/EGSM 900 GSM 1800/1900	330mA 260mA
6	Operating Temperature	Normal operation: -30°C to +85°C Restricted operation: -40°C to -30°C, +85°C to +90°C	
7	Data Transfer	GPRS Multi-slot Class 12 max 85.6kbps (Downlink and Uplink) Full PBCCH Support Mobile Station Class B Coding Scheme 1~4 PPP stack	
		CSD V.110, RLP, non-transparent @2.4, 4.8, 9.6 & 14.4kbps USSD	
		PPP-stack for GPRS data transfer	
8	SMS	Point-to-Point MT and MO Cell Broadcast Text and PDU Mode Storage: SIM Card plus 25 SMS locations in mobile equipment Transmission of SMS alternatively over CSD or GPRS. Preferred mode can be user defined.	
9	AT Commands	AT-Hayes 3GPP TS 27.007, TS 27.005	
10	TCP/IP Stack	Access by AT Commands Internet Services include TCP, UDP, HTTP, FTP, SMTP	
11	Serial Interface	RJ45 connector 8-wire Modem Interface with status and control lines, unbalanced, asynchronous Fixed bit rate: 300bps to 460,800bps Autobauding: 1,200bps to 460,800bps Flow Control: Hardware RTS0/CTS0 and Software XON/OFF Multiplex ability according to GSM 07.10 Multiplexer Protocol	

S/N	Feature	Specifications
12	SIM Interface	SIM Card Slot Supports SIM Cards: +3V and +1.8V
13	Antenna	50 ohms via External SMA Connector
14	Software Reset	Orderly Shut down and Reset by AT Command (AT^SMSO)
15	 RoHS	All hardware components are fully compliant with the EU RoHs directive 2002/95/EC Exception: MLB55IN

Table 2: Features and Specifications

1.5 Precautions

The MLB-G3002 terminal is designed for indoor use only. For outdoor use it has to be integrated into a weatherproof enclosure. Do not exceed the environmental and electrical limits as specified in the user manual.

2 MECHANICAL DESCRIPTION

2.1 Overview

The pictures below show the mechanical design of the terminal along with the positions of the different connectors. The terminal case is made of durable PC/ABS plastic.

2.2 Dimensions

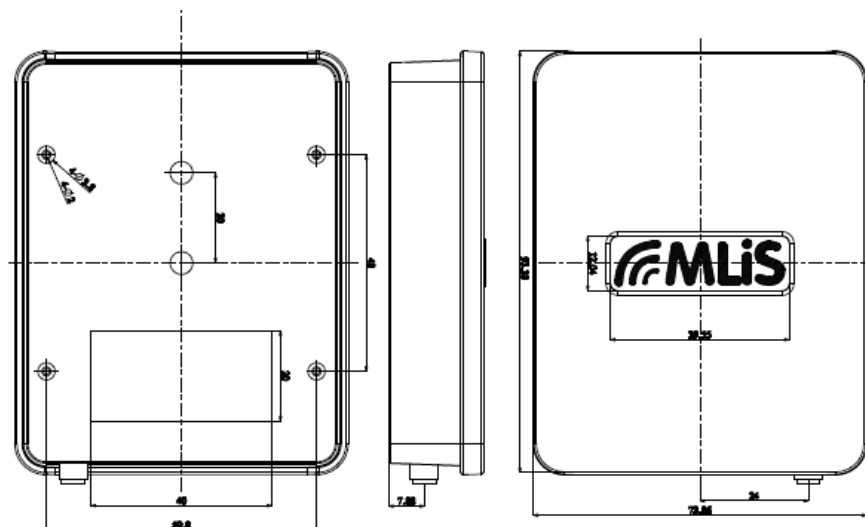

Figure 2: Chassis Dimension for MLB-G3002

S/N	Parameter	Value
1	Height (H)	20.00mm
2	Length (L)	93.33mm
3	Width (W)	73.86mm
4	Weight	90g
5	Chassis Material	Plastic
6	Mounting Standard	Suitable for use with DIN Rail Clips

Table 3: Chassis Dimensions and Mechanical Description for MLB-G3002

3 ELECTRICAL INTERFACE DESCRIPTIONS

3.1 Overview



Front/Back View

Figure 3: External Interfaces/Indicators for MLB-G3002

The interfaces and indicators for MLB-G3002 are as follows:

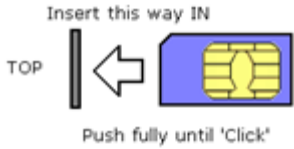
Item	Description	Function
1	USB interface	USB Micro-B 5 interface Communication port via USB * Need install USB driver
2	Radio Interface RF Connector (SMA Female)	Connects to external 50 ohms antenna with correct frequency band
3	SIM Card Interface Slot 	Push SIM card totally into 'locking positing;. Press again to eject SIM card. Push SIM card totally into 'locking position'. Press again to eject SIM card Insert or retrieve SIM card without Power Accepts both +1.8V and +3V SIM cards Insert with SIM card contacts face up
4	RJ45 568B Connector	For Power and Communications

Item	Description	Function
5	LED (Blue)	LED of Network status (See chapter 4.3)
6	LED (Green)	Power LED
7	Extend I/O	See chapter 3.5

Table 4: Interfaces and Indicators Description of MLB-G3002

3.2 Radio Interface (Type SMA Connector Female) - RF Antenna



Figure 4: Antenna Connector for MLB-G3002

The connection of the antenna or other equipment must be decoupled from DC voltage.

For optimum RF performance, the MLiS Terminal has to be connected to an external RF antenna matched to 50ohms including other connecting cables across the operating frequency bands. Please use a SMA Male connection for the terminal.

Choose suitable types of low attenuation coaxial cables if possible. In general the ohm types RG174 or RG58 50 can be used. Avoid excessive cable length of > 10 meters.

- * **Compatible RF antennas (PCB patched or Monopole type) are available for order, please refer to accessories document.**

3.3 RJ45 Connector

The RJ45 Modular COM port is used to supply power to the terminal as well as provide serial data communication. The terminal accepts voltage levels between +5Vdc to +32Vdc. Do not exceed these levels. The minimum requirement, for the terminal to communicate with the application or DTE, is established through using the following pins:

- TxD: Where the Application sends data to MLI_S Terminal
- RxD: Where the Application receives data from MLI_S Terminal



Figure 5: RJ45 Connector Pin Definition for MLB-G3002

The table below defines the RS232 Socket pin configuration on the Terminal:

Pin No.	Signal Name	I/O	Function
1	VIN	-	DC Input +5V ~ +32V
2	RTS	O	Request To Send
3	CTS	I	Clear to Send
4	RxD	I	Receive Data
5	TxD	O	Transmit Data
6	GND	-	Ground
7	DTR	I	Data terminal ready
8	DSR	O	Data Set Ready

Table 5: RJ45 connector configuration for MLB-G3002

3.4 SIM card holder

The MLB-G3002 Terminal is provided with a SIM card reader designed for 1.8V and 3V SIM cards. It is the flip-up type which can be locked. It can be accessed through removing the battery cover as shown below.

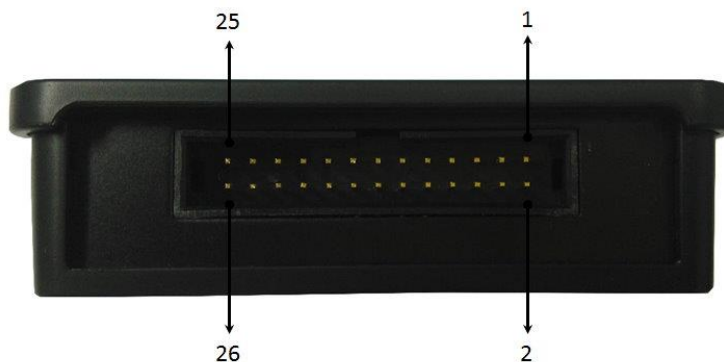

Figure 6: SIM Card Holder for MLB-G3002

*** Be sure to power off the modem when you replace the SIM card. Otherwise it may cause damage to the equipment.**

The MLB-G3002 fully operates when inserting a SIM card. Some MLB-G3002 functionality may be lost if you try to operate the terminal without a SIM card

3.5 Extend I/O



If users would like to use these pins to control module by Java, all definition of pins connect to the same name on module and working voltage is 1.8V.

Pin no.	Signal name	Pin no.	Signal name
1	GPIO4	14	GPIO24
2	GPIO6	15	V180
3	GPIO7	16	GND
4	GPIO8	17	I2CDAT
5	1.8V	18	I2CCLK
6	GND	19	GPIO20
7	GPIO16	20	GPIO21
8	GPIO17	21	GPIO22
9	GPIO18	22	GPIO23
10	GPIO19	23	NC
11	3.3V	24	GND
12	GND	25	ADC1
13	GND	26	GND

4 OPERATING MODES

4.1 Power on the Modem

The modem is usually fully operational within 4 seconds, after powering it up. Depending on the signal strength of the network in the area, logging into a network may take longer and is outside the control of the modem.

4.2 Power off the Modem

There are 2 ways to switch off (power down) the modem as described below:

a) The “**AT^SMSO**” command lets the MLB-G3002 terminal log off from the network and allows the software to enter into a secure state and save data before disconnecting the power supply. The mode is referred to Power-down mode. In this mode only the RTC stays active.

Make sure that the terminal has completely shut down before disconnecting the power supply. The URC “**^SHUTDOWN**” indicates that data have been stored non-volatile and the terminal turns off in less than 1 second.

b) Direct hardware power off. Data will not be retained in this case.

4.3 LED Status via LED

LED Status	<mode>=1	<mode>=2 <flash>= default	<mode>=2 <flash>= user defined
<ul style="list-style-type: none"> - GSM CS data call in progress or established - GSM voice call in progress or established - UMTS voice call in progress or established - UMTS CS data call in progress 	Permanently on	10 ms on / 990 ms off	<flash> ms on / 990 ms off
<ul style="list-style-type: none"> - GSM PS data transfer - UMTS data transfer 	Permanently on	10 ms on / 1990 ms off	<flash> ms on / 1990 ms off
ME registered to a network. No call, no data transfer	Permanently on	10 ms on / 3990 ms off	<flash> ms on / 3990 ms off
Limited Network Service (e.g. because no SIM/ USIM, no PIN or during network search)	500ms on / 500 ms off	500ms on / 500 ms off	500ms on / 500 ms off

5 Command Operation

5.1 Command Operation for SMS

Flow chart :

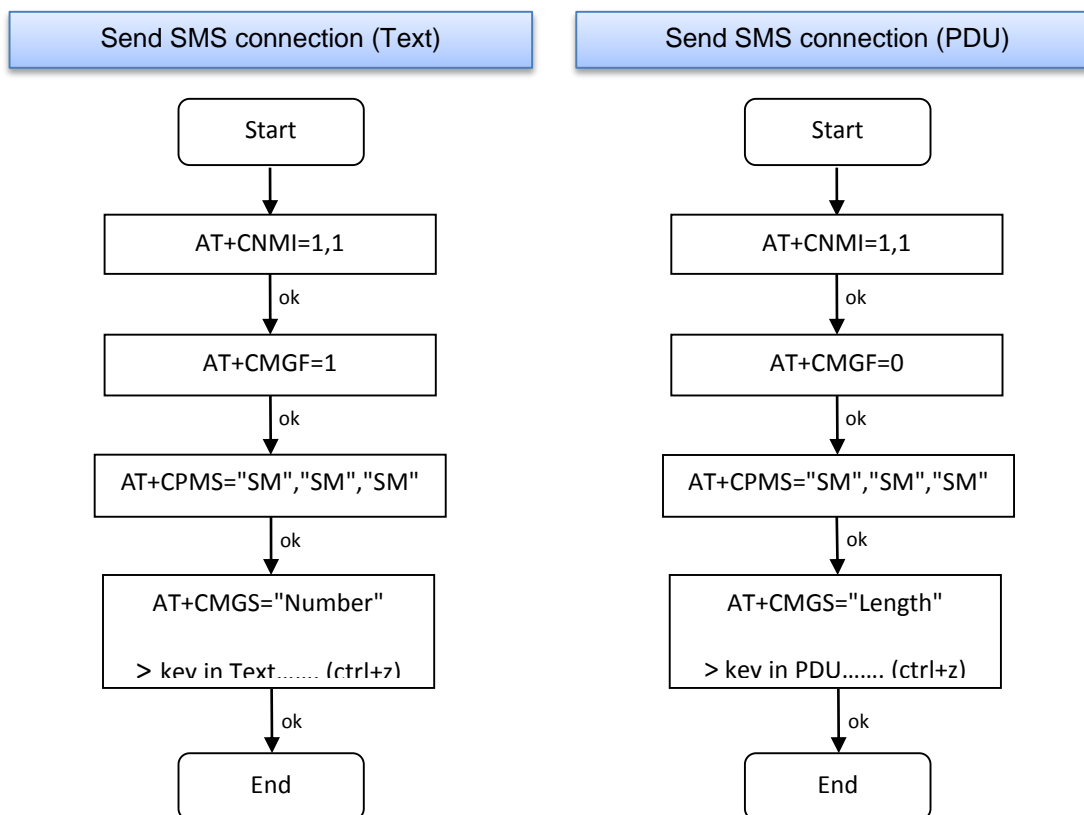

5.1.1 SMS Explanation

AT+CNMI New short Message Indication

AT+CNMI=1,1

AT+CMGF Select SMS message format

AT+CMGF=1

Text mode=1; PDU mode=0

AT+CPMS Preferred SMS message storage

AT+CPMS=<mem1>[, <mem2>[, <mem3>]]

+CPMS: <used1>, <total1>, <used2>, <total2>, <used3>, <total3>

< mem1 >^(str)

Memory to be used when listing, reading and deleting messages:

"BM" Broadcast message storage

"ME" Mobile Equipment message storage

"SM" (P) USIM message storage

"SR" Status report message storage

< mem2 >^(str)

Memory to be used when writing and sending messages:

"ME" Mobile Equipment message storage

"SM" (P) USIM message storage

< mem3 >^(str)

Received messages will be placed in this memory storage if routing to TE is not set. See command AT+CNMI with parameter <mt>=2. received CBMs are always stored in "BM" unless directly forwarded to TE. Received status reports are always stored in "SR" unless directly forwarded to TE.

"BM" Broadcast message storage

"ME" Mobile Equipment message storage

"SM" (P) USIM message storage

"SR" Status report message storage

< used1 >^(num)

Number of messages currently in <mem1>

< used2 >^(num)

Number of messages currently in <mem2>

< used3 >^(num)

Number of messages currently in <mem3>

< total1 >^(num)

Number of messages storable in <mem1>

< total2 >^(num)

Number of messages storable in <mem2>

< total3 >^(num)

Number of messages storable in <mem3>

AT+CMGS="Number"

> key in Text

ctrl+z Send Short Message

If text mode (see AT+CMGF=1)

AT+CMGS="Length"

> key in PDU

ctrl+z Send Short Message

If PDU mode (see AT+CMGF=0)

New SMS View

AT+CNMI New short Message Indication

AT+CNMI=1,1

AT+CMGR Read SMS messages

AT+CMGR=1

AT+CMGL List SMS messages from preferred store

AT+CMGL="ALL"

AT+CMGD Delete short message

AT+CMGD=4

5.2 Command Operation for Socket mode

Flow chart :

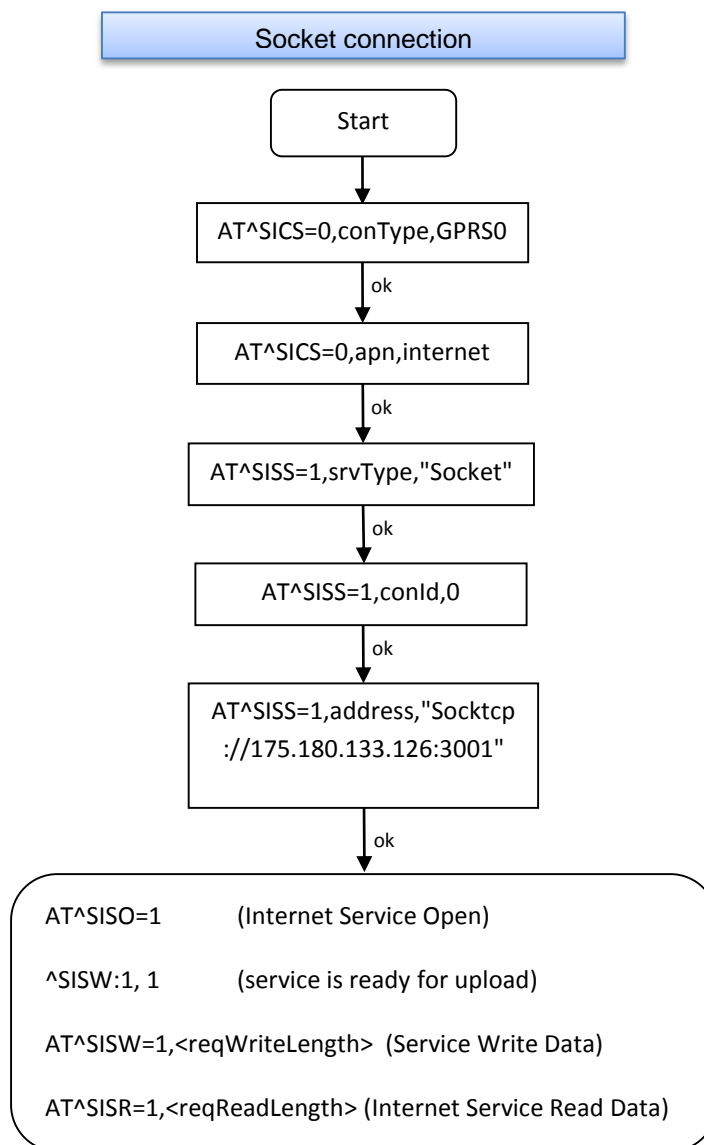

5.2.1 Command Operation for Transparent Socket mode

Flow chart :

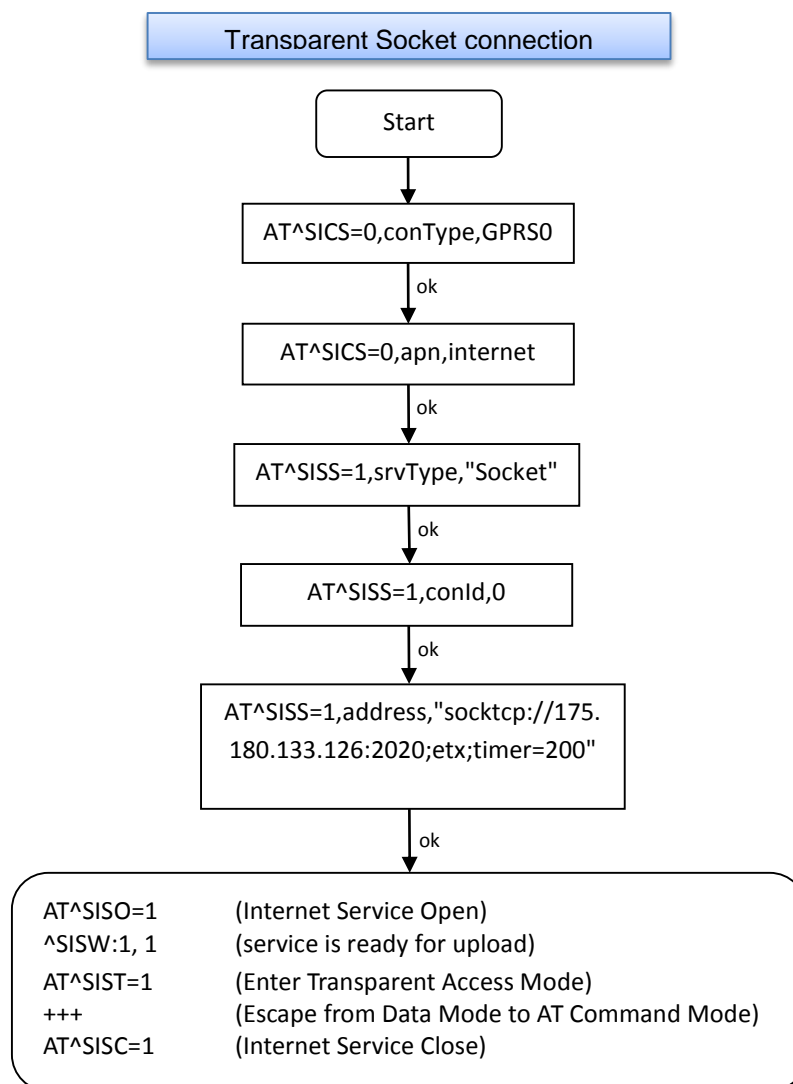

5.3 Command Operation for FTP mode

FTP Download to FFS

AT^SICS=0,conType,GPRS0	Select connection type GPRS0.
OK	
AT^SICS=0,apn,"internet"	APN to access the GPRS services provided by the internet.
OK	
AT^SISS=1,svrType,"Ftp"	Select service type FTP.
OK	
AT^SISS=1,conId,0	Select connection profile 0.
OK	
AT^SISS=1,address,"ftp://175.180.133.126:21"	Specify FTP address.
OK	
AT^SISS=1,cmd,"fget"	Select command type download.
OK	
AT^SISS=1,user,"test01"	
OK	
AT^SISS=1,passwd,"1234"	
OK	
AT^SISS=1,path,"file:///d:/data/"	Specify target path on local FFS.
OK	
AT^SISS=1,files,"INDEX"	Specify file to be downloaded.
OK	
AT^SISO=1	Open the service.
OK	Bearer is established, service is getting started.
^SIS: 1,0,2100,"Ftp open(175.180.133.126:21)"	"^SIS" URC with <urcInfold> 2100 (FTP) indicates download status.

^SIS: 1,0,2100,"220-FileZilla Server version 0.9.41"

^SIS: 1,0,2100,"FTP Login OK"

^SIS: 1,0,2100,"fget INDEX"

^SIS: 1,0,2100,"FGET : INDEX 225 bytes"

^SISR: 1,2

Download complete.

AT^SISO?

Request service state.

^SISO:

1,"Ftp",4,1,225,0,"175.180.72.231:3001","175.180.133.126:21"

AT^SISC=1

Close the service.

OK

AT^SISO?

Request service state.

^SISO:

Service is closed and reset.

1,"Ftp",2,1,0,0,"0.0.0.0:0","0.0.0.0:0"

FTP Upload Single File

AT^SICS=0,conType,GPRS0	Select connection type GPRS0.
OK	
AT^SICS=0,apn,"internet"	APN to access the GPRS services provided by the internet.
OK	
AT^SISS=1,svType,"Ftp"	Select service type FTP.
OK	
AT^SISS=1,conId,0	Select connection profile 0.
OK	
AT^SISS=1,address,"ftp://test:1234\175.180.133.126:21/upload"	Specify FTP address with individual user name and password.
OK	
AT^SISS=1,cmd,"put"	Select command type upload for single file.
OK	
AT^SISS=1,path,"file:///d:/data/"	Specify path on local FFS.
OK	
AT^SISS=1,files,"text.txt"	File " text.txt " shall be put on FFTP server.
OK	
AT^SISO=1	Open the service.
OK	
^SIS: 1,0,2100,"Ftp open(175.180.133.126:21)"	Bearer is established, service is getting started. " ^SIS " URC with <urcInfold> 2100 (FTP) indicates download status.
^SIS: 1,0,2100,"220-FileZilla Server version 0.9.41"	
^SIS: 1,0,2100,"FTP Login OK"	
^SIS: 1,0,2100,"put test.txt"	
^SISW: 1,1	
AT^SISW=1,40	

<p>^SISW: 1,40,0</p> <p>01234567890123456789012345678901234567890</p> <p>OK</p> <p>^SISW: 1,1</p>	<p>URC indicates that FTP service is ready for upload.</p> <p>Client requests to send 40 bytes.</p> <p>The write command response confirms that 40 bytes must be transferred now.</p> <p>User data is transferred.</p>
<p>AT^SISW=1,40</p> <p>^SISW: 1,40,0</p> <p>01234567890123456789012345678901234567890</p> <p>OK</p> <p>^SISW: 1,1</p>	<p>URC indicates that the FTP service is ready to transfer more data.</p> <p>Client requests to send 40 bytes.</p> <p>The write command response confirms that 40 bytes must be transferred now.</p> <p>User data is transferred.</p>
<p>AT^SISW=1,0,1</p> <p>^SISW: 1,0,0</p> <p>OK</p> <p>^SIS: 1,0,2100,"226 Transfer complete."</p> <p>^SISW: 1,2</p>	<p>URC indicates that the FTP service is ready to transfer more data.</p> <p>No more data available. <eodFlag> set. File "test.txt" shall be closed on FTP server.</p>
<p>AT^SISC=1</p> <p>OK</p>	<p>URC indicates that data transfer finished successfully. Connection to the FTP server closes.</p> <p>Close the service.</p>

5.4 Command Operation for HTTP mode

HTTP Download Using TLS

AT^SICS=0,conType,GPRS0	Select connection type GPRS0.
OK	
AT^SICS=0,apn,"internet"	APN to access the GPRS services provided by the internet.
OK	
AT^SISS=1,svType,"Http"	Select service type HTTP.
OK	
AT^SISS=1,conId,0	Select connection profile 0.
OK	
AT^SISS=1,address,"https://www.facebook.com"	Specify access to Facebook website (always secured).
OK	
AT^SISS=1,cmd,"get"	Select command type download.
OK	
AT^SISO=1	Open the service.
OK	
^SIS: 1,0,2200,"Http www.facebook.com:443"	
^SISR: 1,1	URC indicates that the HTTP service is ready to read data.
	Read 1000 bytes.
AT^SISR=1,1000	
^SISR: 1,1000	
<?xml version="1.0" encoding="utf-8"?> <!DOCTYPE html PUBLIC "-//WAPFORUM//DTD XHTML Mobile 1.0//EN" "http://www.wapforum.org	
OK	

AT^SISR=1,1000

^SISR: 1,1000

....

^SISR: 1,2

AT^SISC=1

OK

Repeat reading data n times.

URC indicates that data transfer finished success-fully.
Connection to the HTTP server closes.

Close the HTTP service.

HTTP Post

AT^SICS=0,conType,GPRS0	Select connection type GPRS0.
OK	
AT^SICS=0,apn,"internet"	APN to access the GPRS services provided by the internet.
OK	
AT^SISS=1,svrType,"Http"	Select service type HTTP.
OK	
AT^SISS=1,conId,0	Select connection profile 0.
OK	
AT^SISS=1,"address","http://testnetwork/cgi/first.pl"	Specify URL.
OK	
AT^SISS=1,"user","myuser"	Specify user name.
OK	
AT^SISS=1,"passwd","mypasswd"	Specify password.
OK	
AT^SISS=1,cmd,"post"	Select command type download.
OK	
AT^SISS=1,"hcContent"," "	Parameter is ignored.
OK	
AT^SISS=1,"hcContLen","2"	"hcContlen" greater than "0". Data will be sent from AT command interface.
OK	
AT^SISO=1	Open the service.
OK	
^SIS: 1,0,2200,"Http pegasus.testnetz.sw5:80"	
^SISW: 1,1	URC indicates that the HTTP service is ready to send data.

AT^SISW=1,30	Send 30 bytes.
^SISW: 1,30,0	
OK	
^SISW: 1,1	URC indicates that the HTTP service is ready to send data.
AT^SISW=1,30	Send 30 bytes.
^SISW: 1,30,0	
OK	
^SISW: 1,1	URC indicates that the HTTP service is ready to send data.
AT^SISW=1,0,1	Finish input by setting <eodFlag> and start HTTP POST request.
^SISW: 1,0,0	
OK	
^SISW: 1,2	URC confirms: all data sent to server.
OK	
^SIS: 6,0,2200,"HTTP POST: http://testnetwork/cgi/first.pl"	
^SIS: 6,0,2200,"HTTP POST Response: 200"	Read response from server.
^SISR: 1,1	Read 500 bytes.
^SISR: 1,500	Reading 197 bytes.
^SISR: 1,197	
Hello Goodbye	
OK	All data read.
^SISR: 1,1	Close the HTTP service.
AT^SISC=1	
OK	

5.5 Command Operation for SMTP mode

AT^SICS=0,conType,GPRS0	Select connection type GPRS0.
OK	
AT^SICS=0,apn,"internet"	APN to access the GPRS services provided by the internet.
OK	
AT^SISS=9,svrType,"SmtP"	Select service type SMTP.
OK	
AT^SISS=9,conId,"1"	Select connection profile 1.
OK	
AT^SISS=9,address,"smtps://Username\00gmail.com:****\00smtp.gmail.com"	Specify SMTP server address, enter user name and password for SMTP authentication.
OK	
AT^SISS=9,smSubj,"My Test Mail"	Enter text for subject field.
OK	
AT^SISS=9,smFrom,"subscriber1\00gema1to.com"	Sender's email address.
OK	
AT^SISS=9,smRcpt,"subscriber2\00gmail.com,subscriber3\00gema1to.com"	Recipients' email addresses.
OK	
AT^SISS=9,smAuth,"login"	Type of authentication: Sender name and password are used for SMTP authentication.
OK	
AT^SISS=9,smMsg,"This is the message for mail testing."	Write message text.
OK	
AT^SISS=9,path,file:///a:/data/	Specify path on local FFS.
OK	
AT^SISS=9,cmd,"files"	Send attachment located on FFS.

OK

AT^SISS=9,files,"flower.jpg"

OK

AT^SISO=9

Open the service, i.e.start sending the mail.

OK

^SISS: 9,0,4400,"Smt open(smtp.gmail.com:465)"

^SISS: 9,4400,"SSL-Info: TLS, 3.3,
TLS\11ECDHE\11RSA\11WITH\11RC4\11128\11SHA"

^SISS: 9,0,4400,"SSL-Cert: C=US;O=Google Inc;CN=Google
Internet Authority"

^SISS: 9,0,4400,"220 mx.google.com ESMTP
f49sm37686972eec.7 - gsmt"

^SISS: 9,0,4400,"250-mx.google.com at your service,
\1b<37.80.21.126\1b>"

^SISS: 9,0,4400,"Auth OK"

^SISS: 9,0,4400,"Mail send OK"

^SISW: 9,2

AT^SISC=9

URC confirms that data transfer finished
success-fully

OK

Close SMTP service.

5.6 Command Explanation

5.6.1 AT^SICS Internet Connection Setup Profile

AT^SICS=<conProfileId>, <conParmTag>, <conParmValue>

< conProfileId >^(num)

0...5 Internet connection profile identifier.

The <conProfileId> identifies all parameters of a connection profile, and when a service profile is created with AT^SISS the <conProfileId> needs to be set as "conId" value of the AT^SISS parameter <srvParmTag>.

< conParmTag >^(str)

Internet connection parameter

"conType" Type of Internet connection.

For supported values of <conParmValue> refer to <conParmValue-con-Type>.

"user" User name string: maximum 31 characters (where "" is default).

"passwd" Password string: maximum 31 characters (where ***** is default).

"apn" Access point name string value: maximum 99 characters (where "" is default).

"inactTO" Inactivity timeout value in seconds: 0 ... $2^{16}-1$, default = 20

Number of seconds the bearer remains open although the service no longer needs the bearer connection.

Setting the value to 0 does not deactivate the timer. If the value is set to 0, the

bearer is closed immediately after the service no longer needs the connection. Short timeout may result in problems when using the <eodFlag> (set in the last AT^SISW command to terminate an upload data stream). It is possible that the bearer will get closed before the flag will be transmitted. As result the server will not receive the flag. Considering this avoid setting the timeout value below 3 seconds when using the <eodFlag>.

"dns1" Primary DNS server address (IP address in dotted-four-byte format).

This value determines whether to use the DNS server addresses dynamically assigned by the network or a specific DNS server address given by the user.

"dns1" = "0.0.0.0" (default) means that the CSD or GPRS connection profile uses dynamic DNS assignment. Any other address means that the Primary DNS is manually set.

The default value applies automatically if no other address is set. Note that the AT^SICS read command only returns a manually configured IP address, while

the value "0.0.0.0" is not indicated at all, no matter whether assumed by default or explicitly specified.

See also note below. See also note below.

< conParmValue >^(str)

Parameter value; type and supported content depend on related <conParmTag>.

< conParmValue – conType >^(str)

Supported connection type values in <conParmValue> for <conParmTag> value "conType".

GPRS0 GPRS connection.

However, for each configured connection profile there must be a free PDP context in AT+CGDCONT. After entering AT^SISO MLB-G3002 automatically tries to attach to a Packet Domain. Yet, the only exception is AT+CGATT which can be used any time to detach from the Packet Domain and thus disconnect the bearer opened with AT^SISO.

none Clears the connection profile.

The list below shows which <conParmTag> parameters are mandatory (= m) or optional (= o).

<conParmTag>	<conParmValue-conType> GPRS0
"conType"	m
"user"	o
"passwd"	o
"apn"	m
"inactTO"	o
"dns1"	o

Table 6: Applicability of AT^SICS <conParmTag> values

5.6.2 AT^SISS Internet Service Setup

AT^SISS=<srvProfileId>, <srvParmTag>, <srvParmValue>

< srvProfileId >^(num)

Internet service profile identifier.

The <srvProfileId> is used to reference all parameters related to the same service profile. Furthermore, when using the AT commands AT^SISO, AT^SISR, AT^SISW, AT^SIST, AT^SISH and AT^SISC the <srvProfileId> is needed to select a specific service profile.

0...9

< srvParmTag >^(u)

Internet service profile parameter.

srvType Type of Internet service to be configured with consecutive usage of AT^SISS.

For supported values of <srvParmValue> refer to <srvParmValue-srv-Type>.

user User name string for FTP, HTTP, SMTP authentication.

Parameter is optional: The user name can be set by <srvParmTag> parameter "user" or as part of "address" parameter.

For HTTP only simple authentication is supported. Length: 32 octects

passwd Password string for FTP, HTTP, SMTP authentication.

Parameter is optional: The password can be set by <srvParmTag> parameter "password" or as part of "address" parameter. Length: 32 octects

conId Internet connection profile to be used, for details refer AT^SICS.

address String value containing the URL for the specific service:

1. Non-transparent Socket

- TCP client URL

"socktcp[s]://<host>:<remotePort>[:keepidle=
<value>][:keepcnt=<value>][:keepintvl=<value>]"

- TCP server URL

"socktcp://listener:<localPort>[:keepidle=
<value>][:keepcnt=<value>][:keepintvl=<value>]"

-
- UDP endpoint URL

```
"sockudp://:<localPort>"
```

- UDP client URL

```
"sockudp://<host>:<remotePort>[:port=<localPort>]"
```

2. Transparent Socket

- Transparent TCP client

```
"socktcp[s]://<host>:<remotePort>;etx[=<etx-Char>][:timer=<value>]
```

```
[:keepidle=<value>][:keepcnt=<value>][:keepintvl=<value>]"
```

- Transparent UDP client

```
"sockudp://<host>:<remotePort>;etx[=<etxChar>][:timer=<value>]"
```

- Transparent TCP Listener

```
"socktcp://listener:<localPort>;etx[=<etxChar>][:timer=<value>][:autoconnect='0|1]"
```

```
[:connecttimeout=<value>][:keepidle=<value>][:keepcnt=<value>][:keepintvl=<value>]
```

```
[:addrfilter=<filter>]"
```

Supported parameters for Socket services:

- <host>: IP address in the standard dot format (e.g. "192.168.1.2").

- <remotePort>: 1 ... $2^{16}-1$ for the remote port number.

- <localPort>: 1 ... $2^{16}-1$ for the local port number.

- "port": Local port of UDP client:

0: Port number will be assigned from service (default).

- "etx": Parameter is mandatory for Transparent Socket. Otherwise Socket service is non-transparent.

- "<etxChar>": Specifies the character used to change from transparent access mode to AT command mode.

range: 1...15,17...255 (16 is not allowed because it is used as DLE (0x10))

If parameter is not set no escaping is configured, thus requiring either +++ or DTR ON-OFF transition for changing to AT command mode. If value is set, the transmitted bytes are parsed for the DLE (0x10) character followed by the specified <etxChar> value. If both characters are found the service returns to AT command mode without transmitting these two bytes (same as +++).

-
- "timer": The parameter configures the Nagle algorithm, which is used in transparent access mode.
range: 20...[100]...500 milliseconds in steps of 20
 - "keepidle": specifies the TCP parameter TCP_KEEPIDLE (see RFC1122; not for Transparent UDP client)
range: 1...65535 seconds, 0 disabled (default)
 - "keepcnt": specifies the TCP parameter TCP_KEEPCNT (see RFC1122; not for Transparent UDP client); ignored if option "keepidle" is not set
range: 1...[9]...127
 - "keepintvl": specifies the TCP parameter TCP_KEEPINTVL (see RFC1122; not for Transparent UDP client); ignored if option "keepidle" is not set
range: 1...[75]...255 seconds
 - "autoconnect" (for Transparent TCP Listener service only):
0 ... disabled (default) 1 ... automatically accept incoming client connects
 - "connecttimeout": specifies the time after which incoming client connects are rejected automatically (for Transparent TCP Listener service only)
range: 1...[30]...180 seconds
 - "addrfilter": This option allows to filter incoming client connects based on the IP address of the client (for Transparent TCP Listener service only).

It is possible to specify a maximum of 3 filters separated by commas.

Each filter is specified as 4 numbers separated by dots("<n>.<n>.<n>.<n>"). Each number n can be in the range between 0 and 254. It is allowed to use the wildcard "*" instead of n which matches all. The IP address of any incoming client connect does not match any of the specified filters, then the connect is rejected automatically. If the option is not specified, then all client connects are allowed.

Example: "addrfilter=10.10.0.*,80.190.158.9" - allows connects from 10.10.0.81 and 80.190.158.9 but not from 10.10.17.81 and 80.190.158.10.

3. FTP

"ftp[s]://[<user>:<passwd>\00]<host>:<port>/<path>"

"ftp://": The default TCP port 21 for ftp server is used.

"ftps://": The default SSL port 990 for secure ftp server is used.

<host>: element can be an IPv4 address or DNS FQDN string.

<port>: element can be set optional and replace the default port.

<user>: username for authentication, 32 octets. Can be set as part of "address" or separately by <srvParmTag> parameter "user".

<passwd>: password for authentication, 32 octets. Can be set as part of "address" or separately by <srvParmTag> parameter "passwd".

<path>: path of file or directory.

4. HTTP

HTTP client URL

Length: 6...255

"http[s]://[<user>:<passwd>\00]<server>:<port>/<path>"

<server>: FQDN or IP-address

<path>: path of file or directory

<port>: If parameter is omitted the service connects to HTTP default port 80.

<user>: username for authentication, 32 octets.

<passwd>: password for authentication, 32 octets.

"https://": Used for SSL connection.

Refer to "IETF-RFC 2616".

5. SMTP

"smtp[s]://[<user>:<passwd>\00]<host>:<Port>"

"smtp://": The default TCP port 25 for smtp server is used.

"smtps://": The default SSL port 465 for secure smtp server is used.

<host>: element can be an IPv4 address or DNS FQDN string.

<port>: element can be set optional and replace the default port.

<user>: username for authentication, 32 octets. Can be set as part of "address" or separately by <srvParmTag> parameter "user".

<passwd> is for authentication, 32 octets. Can be set as part of "address" or separately by <srvParmTag> parameter "passwd".

cmd	<p>1. HTTP service</p> <ul style="list-style-type: none">- "0" or "get": Send HTTP GET request to server- "1" or "post": Send HTTP POST request to server- "2" or "head": Send HTTP HEAD request to server <p>2. FTP service</p> <ul style="list-style-type: none">- get [offset]: get a single file from FTP server.- put [offset]: send a single file to FTP server.- dir: List the directory on the FTP server and show file size.- list: List the directory on the FTP server without showing file size.- fget: Get multiple files listed in <srvParmTag> parameter "files".- fput: Send multiple files listed in<srvParmTag> parameter "files".- size: Request the size of the file element on the FTP server. The size result is output as "^SIS" URC.- del: Delete a file on FTP server- append: Append data to existing file on FTP server- unique: Selects the FTP Store Unique command to create a file name unique to the current directory. If the file name is assigned by the server then the "^SIS" URC will appear, indicating <urInfold> 2100 and the file name. <p>"offset" is an optional parameter for "get" and "put". It allows resuming a broken uplink or downlink transfer to resend data. The <OffsetString> value specifies the offset in number of octets to start the transfer from. Maximum length is 16 digits. For "get" the <OffsetString> value must be calculated from the <urInfold> 2100 of the "^SIS" URC requested before by using "size".</p> <p>3. SMTP service</p> <ul style="list-style-type: none">- files: send multiple files listed in the <srvParmTag> parameter "files". Max. 5 files allowed.- at: send a single attachment to the server.
path	<p>Path on the local FFS. Specifies drive prefix and pathname.</p> <p>Optional for FTP. Mandatory for SMTP.</p>

Default: AT^SISW=<srvProfileId>,"path","file:///a:".

ftpath Specifies the path of the remote FTP server after login. If no path is set the default path will be used.

flies Specifies single or multiple files:

- Single file for upload to or download from servers in case of HTTP, FTP or SMTP.
- List of files located on the FFS when "cmd" parameter is given with parameters "fput", "fget" or "files". Maximum 5 files can be handled, separated by comma.

hcContent Optional parameter for HTTP method "Post".

Length: 0...254

Can be used to transfer a small amount of data. The content of this string will only be sent if "hcContLen" = 0.

To transmit a larger amount of data "hcContLen" must be set to a non-zero value. In this case the "hcContent" string will be ignored, and data transmission from the client to the server is done with AT^SISW.

hcContLen Mandatory parameter if HTTP "post" is set with <srvParmTag> parameter "cmd".

Length: 0... $2^{31}-1$

The content length shall be set in the header of the HTTP "Post" request before the data part is transferred.

If "hcContLen" = 0 then the data given in the "hcContent" string will be posted.

If "hcContLen" > 0 then the AT^SISW command will be used to send data from the client to the server. In this case, "hcContLen" specifies the total amount of data to be sent. The data can be sent in one or several parts. For each part, the transmission is triggered by the URC "^SISW: x, 1", then the AT^SISW write command can be executed. Data transmission must be terminated with end-ofdata flag: AT^SISW=x,0,1>. See <eodFlag> for more information.

hcUsrAgent The user agent string must be set by the application to identify the mobile. Usually operation system and software version info is set with this browser identifier.

Length: 0...254

hcProp Parameter for several HTTP settings.

Length: 0...254

The general format is 'key': <space> 'value'

Multiple settings can be given separated by "\0d\0a" sequences within the string, do not put them at the end.

Possible 'key' values are defined at HTTP/1.1 Standard RFC 2616.

smFrom Email sender address, i.e. "MAIL FROM" address (string).

Length: 6...254

A valid address parameter consists of local part and domain name delimited by a '@' character, e.g. "john.smith@somedomain.de".

smRcpt Recipient address of the email, i.e. "RCPT TO" address (string).

Length: 6...254

If multiple recipient addresses are to be supplied the comma character is used as delimiter to separate individual address values, e.g. "john.smith@somedomain.de,tom.meier@somedomain.de". Some mail servers do not accept recipient addresses without brackets <>. It is recommended to use the "RCPT TO" variable with brackets.

smCC CC recipient address of the email (string).

Length: 6...254

If multiple CC recipient addresses are to be supplied the comma character is used as delimiter to separate individual address values, e.g.

"john.smith@somedomain.de,tom.meier@somedomain.de".

smSubj Subject content of the email (string).

Length: 0...254

If no subject is supplied the email will be sent with an empty subject.

smAuth SMTP authentication control flag (numeric).

If "smAuth" = 0 (default): MLB-G3002 performs action without SMTP authentication.

If "smAuth" = "0" or "plain": Authentication with PLAIN authentication

If "smAuth" = "1" or "login": Authentication with LOGIN authentication

If "smAuth" = "2" or "cram": Authentication with CRAM authentication

If "smAuth" = "3" or "none": No authentication (for test environment only, not applicable to real network)

smMsg SMTP message body. If no attachment is defined this is only the content of the email.

- tcpMR** Parameter can be used to overwrite the global AT^SCFG parameter "Tcp/MaxRetransmissions" <tcpMr> for a specific Internet Service connection profile.
- If the parameter is not specified the value specified with AT^SCFG will be used.
- Supported values <srvParmValue> for this parameter are the same as described for <tcpMr>.
- Setting is not relevant for Internet Service "Socket" with type "UDP".
- tcpOT** Parameter can be used to overwrite the global AT^SCFG parameter "Tcp/OverallTimeout"
- <tcpOt> for a specific Internet Service connection profile. If the parameter is not specified the value specified with AT^SCFG will be used.
- Supported values <srvParmValue> for this parameter are the same as described for <tcpOt>.
- Setting is not relevant for Internet Service "Socket" with type "UDP".

The list below shows which <srvParmTag> parameters apply to each Internet service and which of them are mandatory (= m) or optional (= o).

<srvParmTag>	Socket	FTP	HTTP	SMTP
"srvType"	m	m	m	m
"conId"	m	m	m	m
"address"	m	m	m	m
"tcpMR"	o	o	o	o
"tcpOT"	o	o	o	o
"cmd"		m	m	m
"path"		o		m
"files"		m		m
"ftpath"		o		
"smFrom"				m
"smRcpt"				m
"smCC"				o

"smSubj"				m
"smMsg"				m
"smAuth"				m
"hcContent"			o	
"hcContLen"			m	
"hcAgent"			o	
"hcProp"			o	
"user"		o	o	o
"passwd"		o	o	o

Table 7: Applicability of AT^SISS <srvParmTag> values

< srvParmValue >^(str)

Parameter value; type and supported content depend on related <srvParmTag>.

< srvParmValue – srvType >^(str)

Supported Internet service type values in <srvParmValue> for <srvParmTag> value "srvType".

Before changing the "srvType" of an existing service profile be sure that the profile is closed. To verify the connection state of the service profile enter the read command AT^SISI. Only when <srvState>=2 is returned for this specific service profile you can change its service type.

Socket MLB-G3002 acting as client or server (listener) for TCP or UDP. "etx" subparameter in URL configures Transparent mode for Socket service.

If MLB-G3002 is TCP listener at least two service profiles are required. The first socket profile must be configured as listener. The second service profile will be dynamically assigned when a socket connection request from a remote client is incoming. For this purpose, one service profile must be left free (= not configured with AT^SISS). An incoming socket connection request will be indicated by the "^SIS" URC, with the next free <srvProfileId> shown inside the URC as parameter <urclnfold>. The connection request can be accepted or rejected by using the commands AT^SISO or AT^SISC and the ID retrieved from the "^SIS".

Ftp MLB-G3002 acting as FTP client.

Http MLB-G3002 acting as HTTP client.

SmtP MLB-G3002 acting as SMTP client.

none Reset Internet service profile settings. Operation is not allowed if profile is in use, i.e. it was activated via AT^SISO.

< srvParmValue – alphabet >^(str)

Parameter not supported

5.6.3 AT^SISO Internet Service Open

AT^SISO=<srvProfileId>[, <optParam>]

< srvProfileId >^(num)

<srvProfileId> 0 ... 9 specified with AT^SIS.

<optParam>

[0] Normal Operation like AT^SISO= <srvProfileId>

1 Show only service parameter of <srvProfileId>

5.6.4 AT^SIST Enter Transparent Access Mode

AT^SIST=<srvProfileId>

< srvProfileId >^(num)

<srvProfileId> 0 ... 9 specified with AT^SIS.

5.6.5 +++ Switch from data mode to command mode

To prevent the +++ character sequence from being misinterpreted as data, it must be preceded and followed by a pause of at least 1000 ms. The +++ characters must be entered in quick succession, all within 1000 ms.

5.6.6 AT^SISC Internet Service Close

AT^SISC=<srvProfileId>

< srvProfileId >^(num)

<srvProfileId> 0 ... 9 specified with AT^SIS.

5.6.7 AT^SISW Internet Service Write Data

AT^SISW=<srvProfileId>, <reqWriteLength>[, <eodFlag>[, <Udp_RemClient>]]

^SISW: <srvProfileId>, <cnfWriteLength>, <unackData>

Number of data bytes as specified by <cnfWriteLength>.

Unsolicited Result Code

^SISW: <srvProfileId>, <urcCauseId>

Data availability status of the Internet service configured with AT^SISW has changed. The URC is issued when the service is ready to accept new user data. In this context the URC is also issued for the Transparent TCP or Transparent UDP client that supports data transfer via AT^SISW only. URC is not supported for Transparent TCP Listener services.

The URC is disabled in polling mode. See AT^SCFG, parameter "Tcp/WithURCs", <tcpWithUrc>.

< srvProfileId >^(num)

<srvProfileId> 0 ... 9 specified with AT^SISW. Transparent TCP Listener services are not supported.

< reqWriteLength >^(num)

0...1500

Specifies the number of bytes to be sent with AT^SISW or, if set to 0, requests the amount of data already sent with AT^SISW but not yet acknowledged:

- Parameter <reqWriteLength> may be 1...1500 bytes to specify the amount of data to be sent with AT^SISW.
- If parameter <reqWriteLength> equals 0, AT^SISW does not expect any data, but a normal query is performed. This allows the application to explicitly request, in particular at the end of an upload job, the amount of unacknowledged data at the TCP layer indicated by <unackData>.
- If Socket service is selected with UDP protocol
 - <reqWriteLength>=0 can be used to send an empty UDP packet;
 - it is recommended that the size of each data packet be limited to 1460 bytes. Otherwise, it is possible that the following URC occurs: "AT^SISW: <id>, 0, 9, The supplied buffer was too small / large".

< eodFlag >^(num)

End of data indication flag.

[0] No end of data. Other data may follow to be transmitted via the Internet service.

Note for UDP Endpoint service: Value 0 must be set before <Udp_RemClient> parameter although <eodFlag> is not effective for UDP Endpoint.

1 End of data is signalled to the Internet Service. Further AT^SISW write commands

return an error response. However, reading data may be possible. The <eodFlag> is effective only if the <reqWriteLength> equals <cnfWriteLength>, in particular if the <reqWriteLength> equals 0.

End-of-data flag must be enabled for following actions:

- FTP "cmd","put" (sending single file to FTP server)
- SMTP "cmd","at" (sending attachment from AT command interface)
- HTTP "cmd","post" if "hcContLen" is not equal zero (sending large amount of data)

< Udp_RemClient > ^(str)

Service specific parameter of the AT^SISW write command. If the Socket service is configured as UDP endpoint this parameter is mandatory and specifies the IP address (in dotted format) and the UDP port of the remote host. For each write request another IP address and UDP port may be given.

< cnfWriteLength > ^(num)

0...1500 Confirmed number of data bytes which can be transmitted via the Internet service configured in <srvProfileId>. This number may be less or equal to the value requested with <reqWriteLength>. The application has to deliver exactly the number of bytes indicated by <cnfWriteLength>. A 0 value means that no data can be written at this time, i.e. it serves as a flow control mechanism.

< unackData > ^(num)

The value is constantly changing until the entire upload job has completed. If the value equals 0 all data sent so far is acknowledged.

<unackData> includes the <cnfWriteLength> value of the pending write operation. Therefore, the very first write operation of an upload job returns identical values for <cnfWriteLength> and <unackData>.

This mechanism allows the host application to easily verify whether or not the remote host has successfully received the data.

Parameter is not applicable to HTTP, SMTP, Socket with UDP protocol. For these services the counter is always set to 0.

< urcCauseId >^(num)

- 1 The service is ready to accept new user data.
- 2 Data transfer has been finished successfully and Internet service may be closed without loss of data.

5.6.8 AT^SISR Internet Service Read Data

AT^SISR=<srvProfileId>, <reqReadLength>

^SISR: <srvProfileId>, <cnfReadLength>[, <remainUdpPacketLength>[, <Udp_RemClient>]]

Number of data bytes are sent as specified by <cnfReadLength>. If peek operator was used no data bytes are sent.

Unsolicited Result Code

^SISR: <srvProfileId>, <urcCauseld>

Data availability status of the Internet service configured with AT^SISR has changed. The URC is issued when:

- data is available after opening an Internet service or
- less data was confirmed (in <cnfReadLength>) than requested (with <reqReadLength>) during the last "Read Data" operation and new data is available.

< srvProfileId >^(num)

<srvProfileId> 0 ... 9 specified with AT^SISR. Transparent TCP Listener services are not supported.

< reqReadLength >^(num)

0 Peek Operator: Query number of received bytes within internal buffers.

The behaviour of the peek operator depends on the selected Internet service, i.e. it may not be supported by all IP Services.

For "Socket" service configured for UDP the size of the next available UDP packet is returned.

1...1500 Requested number of data bytes to be read via the Internet service specified in <srvProfileId>.

-2 Indicates end of data. Data transfer has been finished (all data have been read) and the service can be closed with AT^SISC.

-1 Applies only to HTTP: Querying number of available bytes is not supported by the HTTP service.

0 Indicates that no further data is available at the moment.

>0 Number of available data bytes. The range is determined by <reqRead-Length>:

If <reqReadLength> was greater than 0, then <cnfReadLength> may be less or equal to the value requested with <reqReadLength>.

If <reqReadLength> equals 0 (peek operator) the value indicated by <cnfReadLength> may be greater than 1500.

< urcCauseId >^(num)

Indicates whether or not data is available for reading with AT[^]SISR and AT[^]SIST.

1 Meaning of value "1" for all services except Transparent TCP service:

Data is available and can be read by sending the AT[^]SISR command. The URC appears when less data was confirmed (in <cnfReadLength>) than requested (with <reqReadLength>) during the last "Read Data" operation and new data is available.

Meaning of value "1" for Transparent TCP service:

If the Transparent TCP service is in AT command mode the "[^]SISR: x, 1" URC notifies the client that the server has sent new data. In this case the client shall enter the AT[^]SIST command to go to transparent access mode and read the data

2 End of data. Data transfer has completed (all data read). The service can be closed with AT[^]SISC.

< remainUdpPacketLength >^(num)

Optional third parameter of the AT[^]SISR write command response displayed only if the Socket service uses the UDP protocol.

The reception of each datagram must be completed before the next datagram can be received. This may be a problem if the buffer of the host application is limited and not designed to handle the maximum packet size of 1500 bytes. To compensate this, the host is advised to request, via <reqReadLength>, an amount less or equal its maximum buffer capacity and wait for the resulting AT[^]SISR write command response with parameter <remainUdpPacketLength>. The benefit of this approach is that the host may properly receive all parts of a UDP datagram, as after each received data part the number of remaining bytes is synchronized, until reading the datagram is finished.

If the currently read datagram is smaller than the number of bytes requested by the host the <remainUdpPacketLength> parameter is omitted.

0 Indicates that all bytes of the current UDP datagram are read.

1...(max. data size)-1 Indicates that the currently read UDP datagram is not yet complete. The displayed value is the remaining number of bytes.

<remainUdpPacketLength> is unequal 0 until reading all parts of the current datagram is finished.

< Udp_RemClient >^(num)

Service specific parameter of the AT[^]SISR write command response. If the Socket service is configured as UDP endpoint this parameter shows the IP address and the UDP port of the remote host that has sent the current UDP data. See example in Section 10.15.8, UDP Scenario.

6 SALES CONTACT

Website : www.schmidt.com	
Singapore	Schmidt Electronics (S.E.A.) Pte Ltd 158 Kallang Way #06-10, Performance Building Singapore 349245 T (65) 6272-7233 F (65) 6273-4750 E info.sg@schmidtelelectronics.com
Malaysia	Schmidt Electronics (Malaysia) Sdn Bhd Suite G2, Ground Floor, Wisma Tecna, No. 18A, Lot 318, Jalan 51A/223, 46100 Petaling Jaya, Selangor Darul Ehsan, Malaysia T (60-3) 7957-1080 F (60-3) 7956-8670 E info.kl@schmidtelelectronics.com
Shenzhen, China	Schmidt & Co., (China) Ltd. Shenzhen Branch Schmidt (Shenzhen) Co., Ltd 3/F Unit E, International Culture Building, Fu Tian Road, Shenzhen 518033 T (86-755) 8376-0232 F (86-755) 8376-0025 E info@schmidthk.com
Taiwan	Schmidt & Co., (Hong Kong) Limited 5/F, 139 Song Jiang Road, Taipei 104, Taiwan T (886-2) 2502-5095 F (886-2) 2502-6717 E info@schmidthk.com
Thailand	Schmidt Electronics (Thailand) Ltd 252/97 (B), 19 th Fl., Tower B, Muang Thai-Phatra Complex Building, Ratchadaphisek Rd., Huaykwang Subdistrict, Huaykwang District Bangkok 10310 Thailand T (66-0) 2693-3445 F (66-0) 2693-3448 E info.th@schmidtelelectronics.com

7 ORDERING INFORMATION

MLiS Product

MLB-G3002: The MLiS Dual-Band 2G/3G terminal

Power Adaptor

MLA-PSP-100: Input: AC 100 ~ 240V

Output: 9V/1.3A DC Jack 5.5/2.1

MLA-PSP-101: US Adapter Plug

MLA-PSP-104: British Adapter Plug

MLA-PSP-103: European Adapter Plug

MLA-PSP-102: Australia Adapter Plug

MLA-CAB-001: DC Jack power line 5.5/2.1

Cable

MLA-CAB-103: RJ45 to DB9 (w/dc jack) Cable

Antenna

MLA-ANT-002: Magnet standalone antenna

MLA-ANT-001: PCB antenna

Mount Kit

MLD-MNT-001: Din rail

Notes:

A series of 20 horizontal dashed lines provided for taking notes.

