

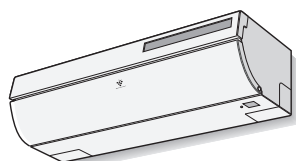

# SERVICE MANUAL

## SPLIT TYPE AIR TO AIR HEAT PUMP



### MODEL 12KHR-N

In the interests of user-safety (Required by safety regulations in some countries) the set should be restored to its original condition and only parts identical to those specified should be used.

### CONTENTS

#### CHAPTER 1. SPECIFICATION

- [1] SPECIFICATION..... 1-1
- [2] EXTERNAL DIMENSION..... 1-2
- [3] WIRING DIAGRAM..... 1-3
- [4] ELECTRICAL PARTS ..... 1-3

#### CHAPTER 2. EXPLANATION OF CIRCUIT AND OPERATION

- [1] BLOCK DIAGRAMS..... 2-1
- [2] MICROCOMPUTER CONTROL SYSTEM... 2-3
- [3] FUNCTION ..... 2-9

#### CHAPTER 3. FUNCTION AND OPERATION OF PROTECTIVE PROCEDURES

- [1] PROTECTION DEVICE FUNCTIONS AND OPERATIONS..... 3-1
- [2] AIR TO AIR HEAT PUMP OPERATION IN THERMISTOR ERROR ..... 3-3
- [3] THERMISTOR TEMPERATURE CHARACTERISTICS ..... 3-5
- [4] HOW TO OPERATE THE OUTDOOR

- UNIT INDEPENDENTLY ..... 3-6
- [5] GENERAL TROUBLESHOOTING CHART... 3-6
- [6] MALFUNCTION (PARTS) CHECK METHOD-OD ..... 3-8
- [7] OUTDOOR UNIT CHECK METHOD ..... 3-10
- [8] TROUBLESHOOTING GUIDE..... 3-14

#### CHAPTER 4. REFRIGERATION CYCLE

- [1] FLOW FOW REFRIGERANT ..... 4-1
- [2] STANDARD CONDITION..... 4-1
- [3] TEMPERATURE AT EACH PART AND PRESSURE IN 3-WAY VALVE ..... 4-1
- [4] PERFORMANCE CURVES..... 4-2

#### CHAPTER 5. DISASSEMBLING PROCEDURE

- [1] DISASSEMBLY OF INDOOR UNIT..... 5-1
- [2] DISASSEMBLY OF OUTDOOR UNIT..... 5-10

#### Parts Guide

Parts marked with "⚠" are important for maintaining the safety of the set. Be sure to replace these parts with specified ones for maintaining the safety and performance of the set.

**CHAPTER 1. SPECIFICATION****[1] SPECIFICATION****1. 12KHR-N**

ITEMS		MODEL	INDOOR UNIT	OUTDOOR UNIT
			12KHR-N	
Rated cooling capacity (Min– Max.)		kW	3.5 (0.9 - 4.0)	
Rated heating capacity (Min–Max.)		kW	4.6 (0.9 - 6.5)	
Moisture removal (at cooling)		Liters/h	1.2	
Electrical data				
Phase			Single	
Rated frequency		Hz	50	
Rated voltage		V	220-240	
Rated current ☆ (Min - Max.)	Cool	A	4.2 (0.9 - 5.7 )	
	Heat	A	5.0( 0.9 - 7.4 )	
Rated input ☆ (Min - Max.)	Cool	W	920 (200- 1250)	
	Heat	W	1075 (160 - 1700)	
Power factor ☆	Cool	%	95	
	Heat	%	92	
Maximum operating current		A	9.6	
Compressor	Type		Hermetically sealed rotary type	
	Model		DA11A1F22F	
	Oil charge		450cc (Ester oil VG74)	
Refrigerant system	Evaporator		Louver Fin and Grooved tube type	
	Condenser		Corrugate Fin and Grooved tube type	
	Control		Expansion valve	
	Refrigerant (R410A)		1180g	
	De-ice system		Micro computer controled reversed systems	
Noise level (at cooling)	High	dB(A)	40	47
	Low	dB(A)	–	–
	Soft	dB(A)	27	–
Fan system				
Drive			Direct drive	
Air flow quantity (at cooling)	High	m3/min.	9.3	32.2
	Low	m3/min.	7.6	–
	Soft	m3/min.	5.2	–
Fan			Cross flow fan	Propeller fan
Connections				
Refrigerant coupling			Flare type	
Refrigerant tube size Gas, Liquid			3/8", 1/4"	
Drain piping mm			O.D φ16	
Others				
Safety device			Compressor: Thermal protector	
			Fan motors: Thermal fuse	
			Fuse, Micro computer control	
Air filters			Polypropylene net (Washable)	
Net dimensions	Width	mm	790	780
	Height	mm	260	540
	Depth	mm	290	265
Net weight		kg	11	36

NOTE: The conditions of star"☆" marked item are based on 'EN14511'.

[2] EXTERNAL DIMENSION

1. Indoor unit

(Unit : mm)

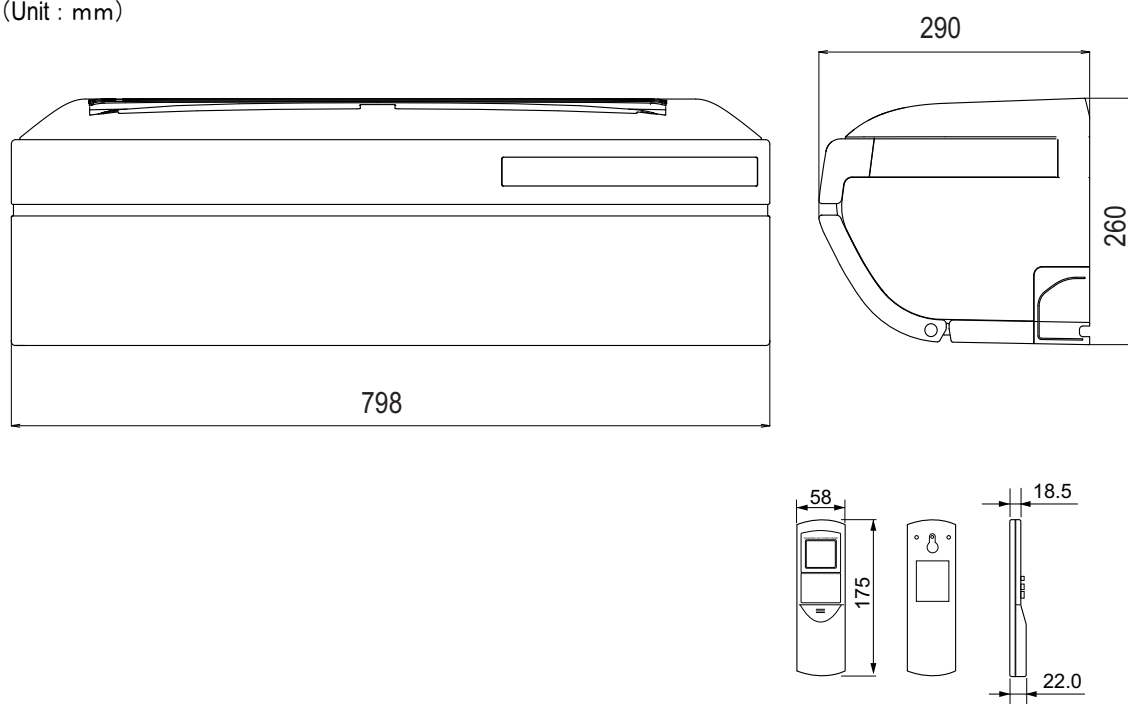

2. Outdoor unit

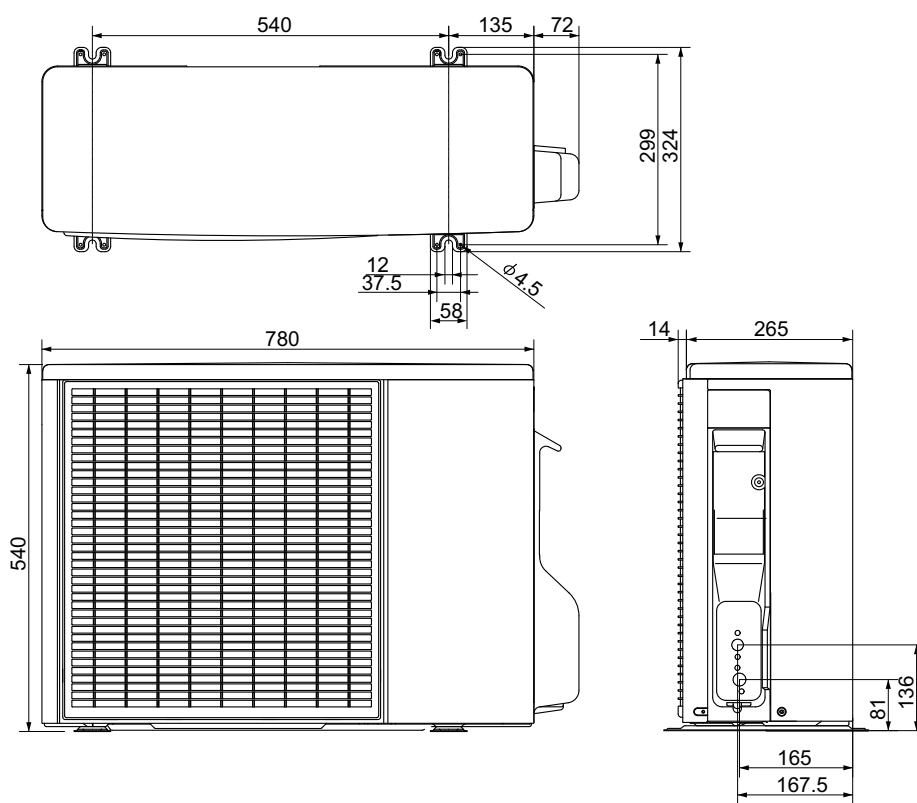

12KHR-N

### [3] WIRING DIAGRAM

#### 1. Indoor unit

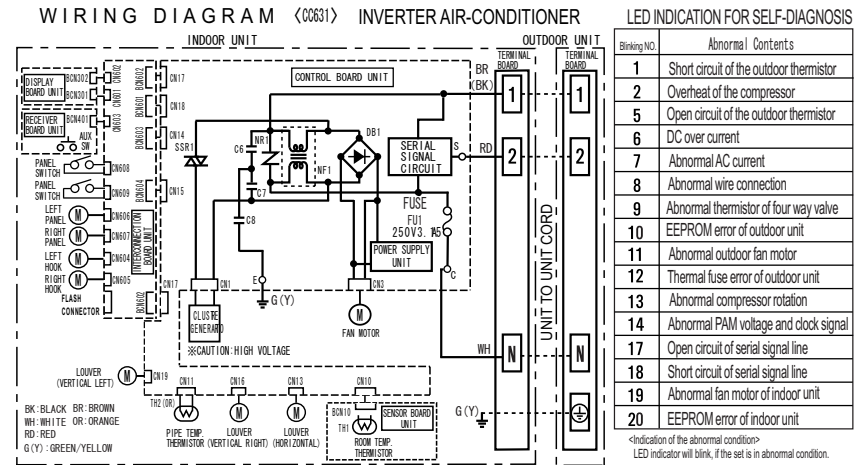

#### 2. Outdoor unit

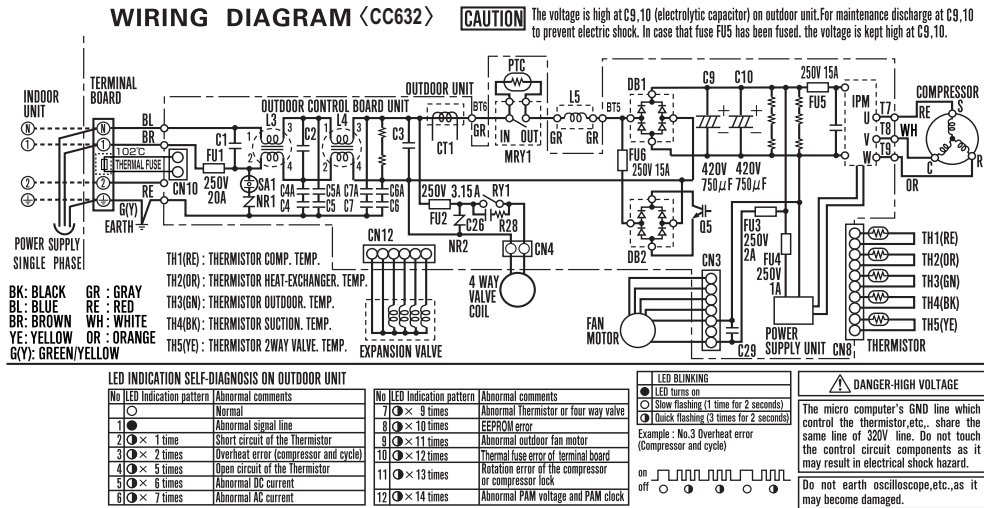

### [4] ELECTRICAL PARTS

#### 1. Indoor unit

DESCRIPTION	MODEL	REMARKS
Indoor fan motor	MLB395	DC motor
Indoor fan motor capacitor	-	-
Transformer	-	-
FUSE1	-	QFS-GA078JBZZ (250V, 3.15A)

#### 2. Outdoor Unit

DESCRIPTION	MODEL	REMARKS
Compressor	DA111A1F22F	DC motor
Outdoor fan motor	MLB078	DC motor
Outdoor fan motor capacitor	-	-
Fu4	-	QFS-GA064JBZZ(250V, 1A)
Fu3	-	QFS-GA051JBZZ(250V, 2A)
Fu2	-	QFS-GA052JBZZ(250V, 3.15A)
Fu1	-	QFS-CA001JBZZ(250V, 20A)
Fu5, 6	-	QFS-CA002JBZZ(250V, 15A)

# CHAPTER 2. EXPLAMATION OF CIRCUIT AND OPERATION

## [1] BLOCK DIAGRAMS

### 1. Indoor unit

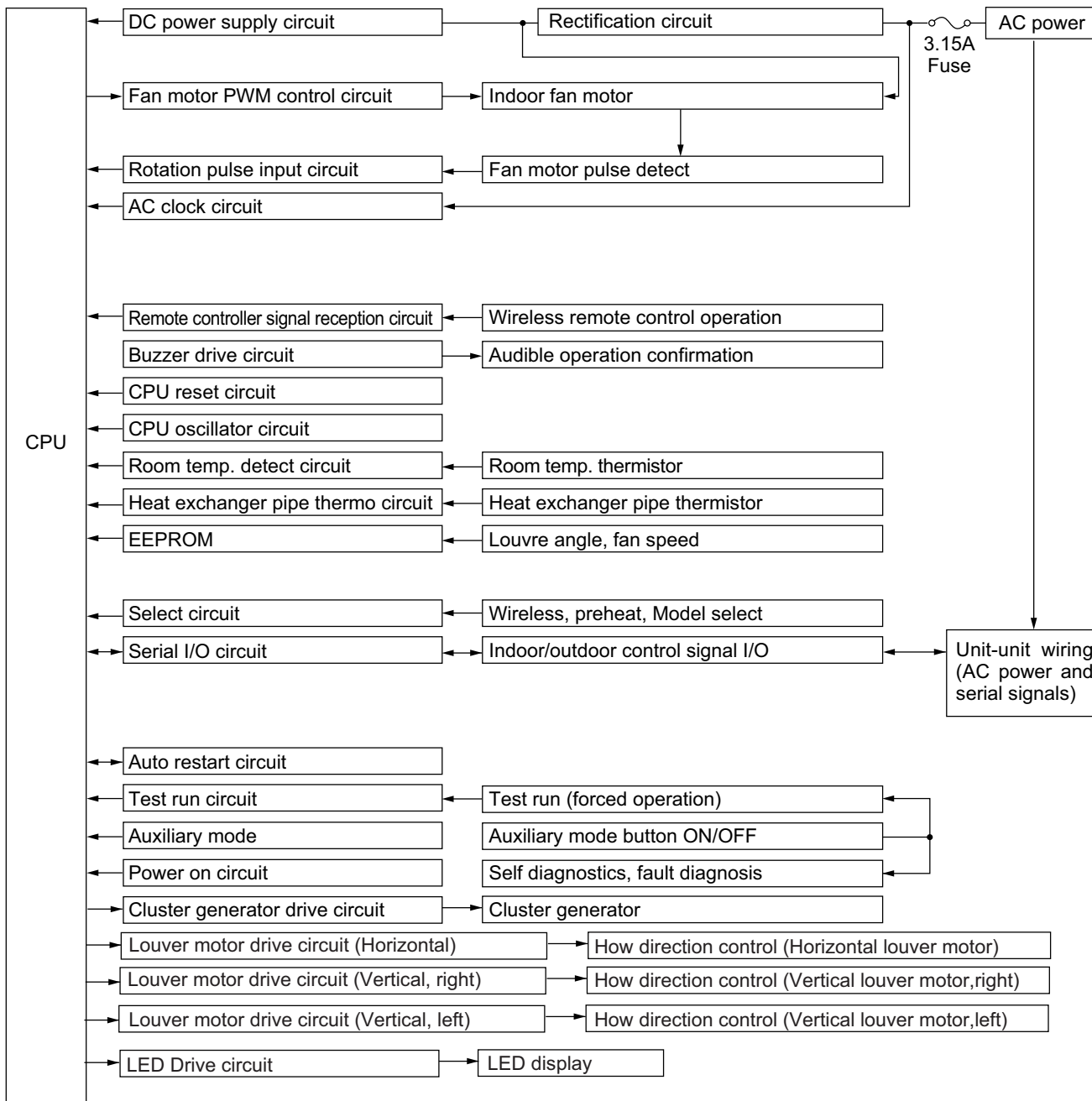

2. Outdoor unit

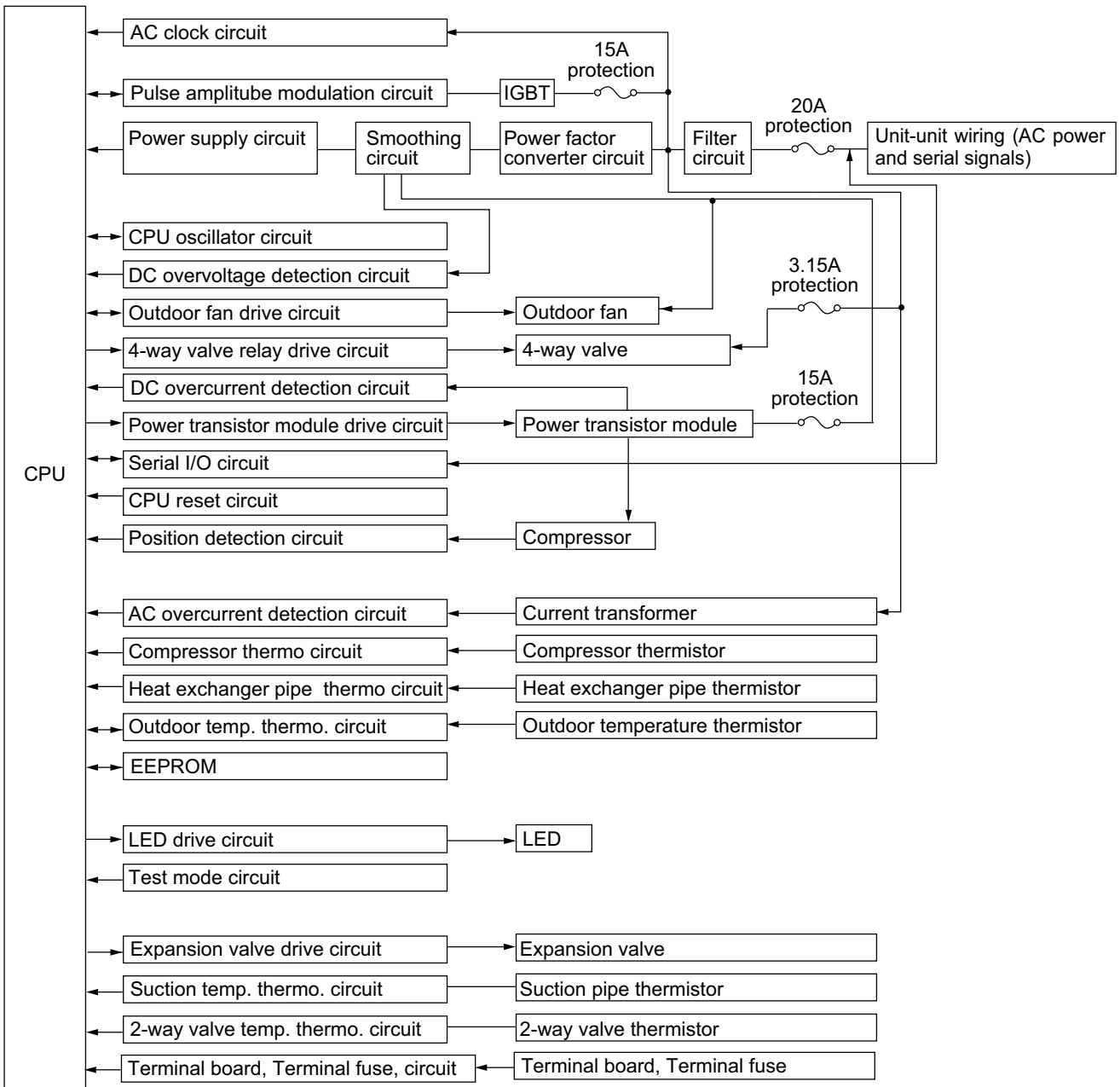



# 12KHR-N

## 1.2. Display circuit diagram

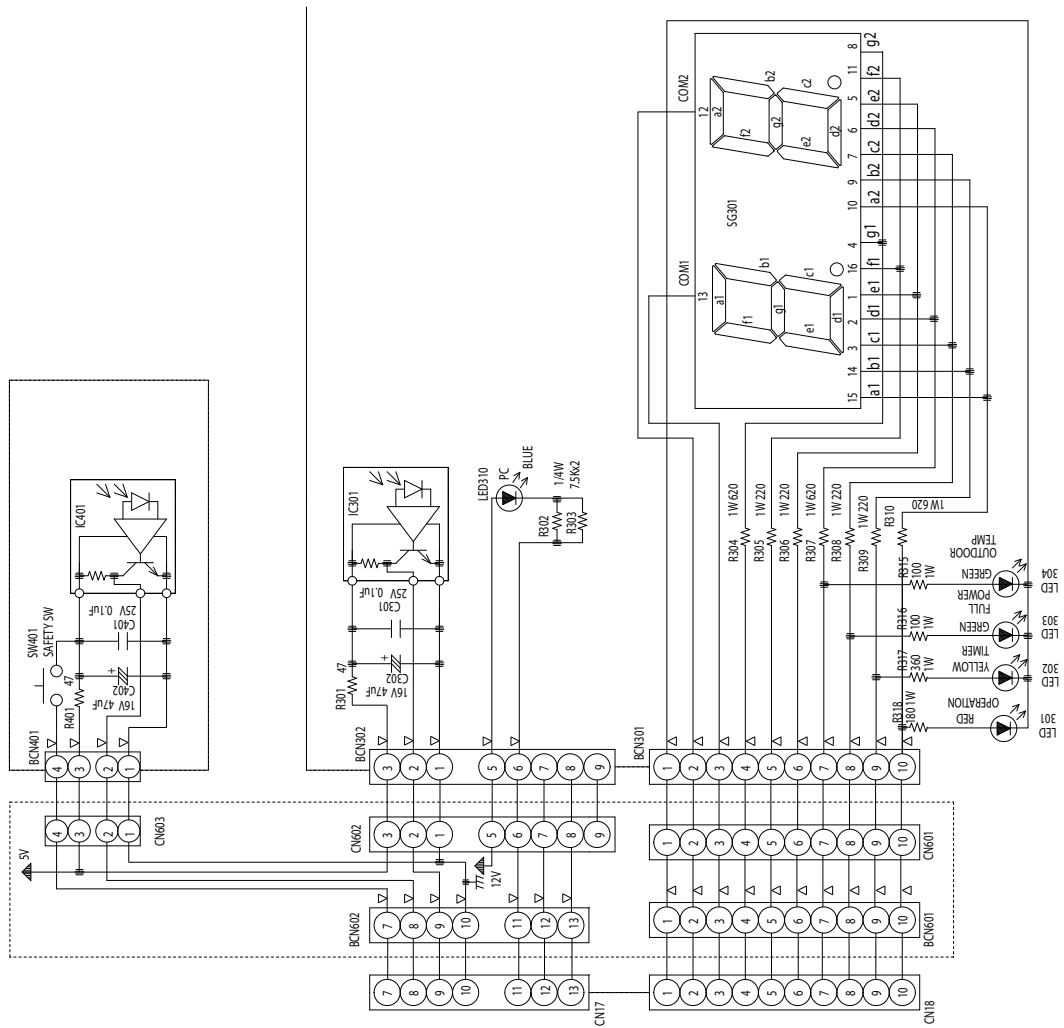



1.3. Printed wiring board

For 2KHN model main PWB

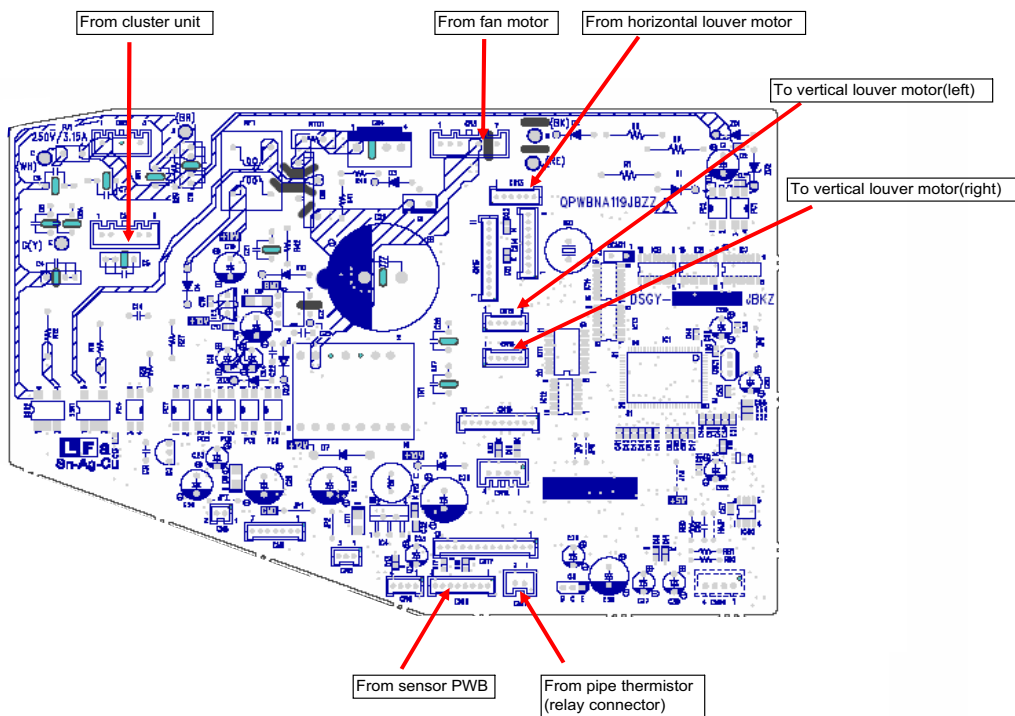

For 2KHN model sensor PWB

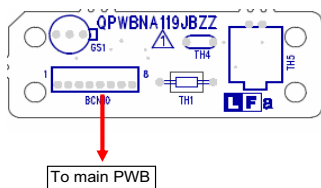

**For 2KHN model connection PWB**

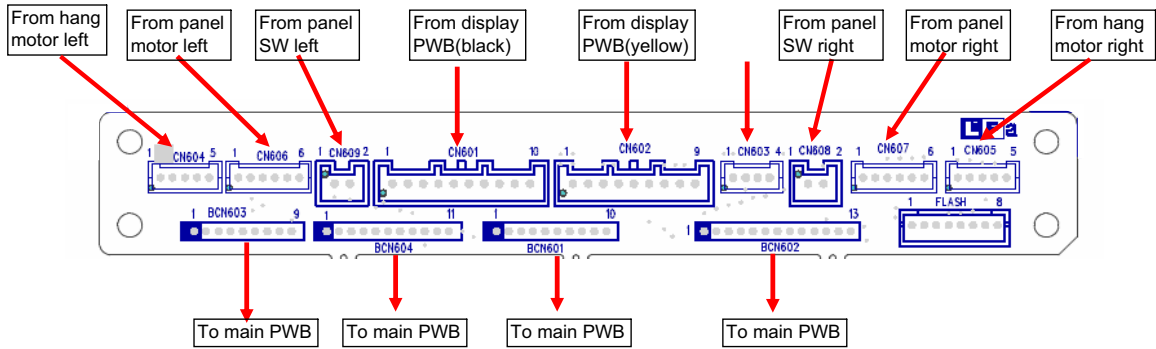

**For 2KHN model display PWB**

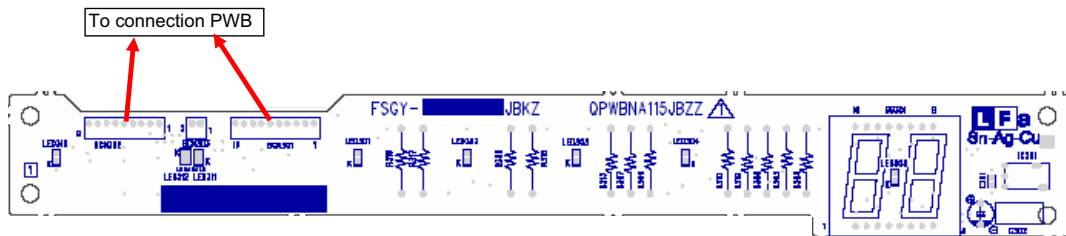

## 2. Outdoor unit

### 2.1. Electronic control circuit diagram

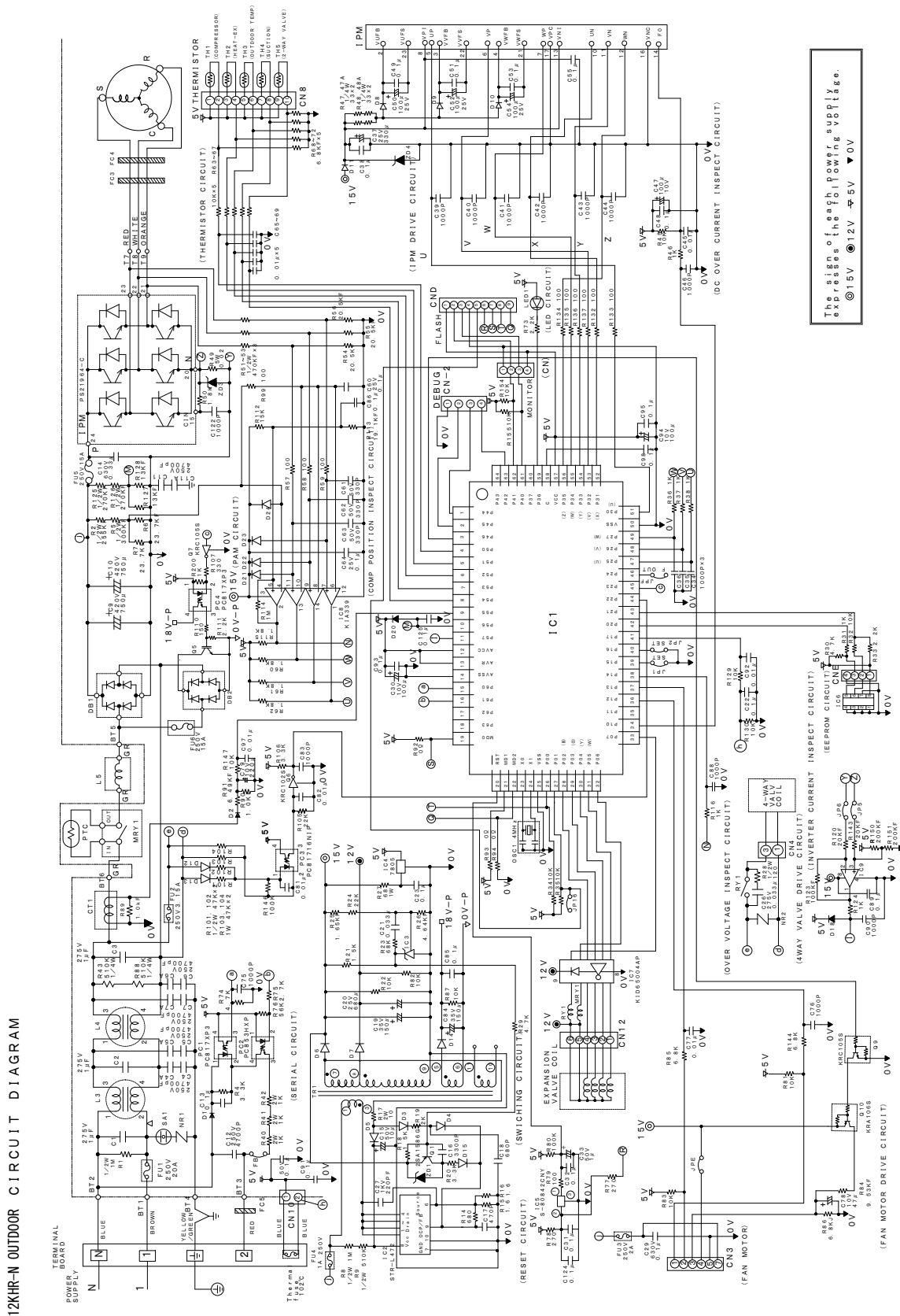

12KHR-N

2.2. Printed wiring board

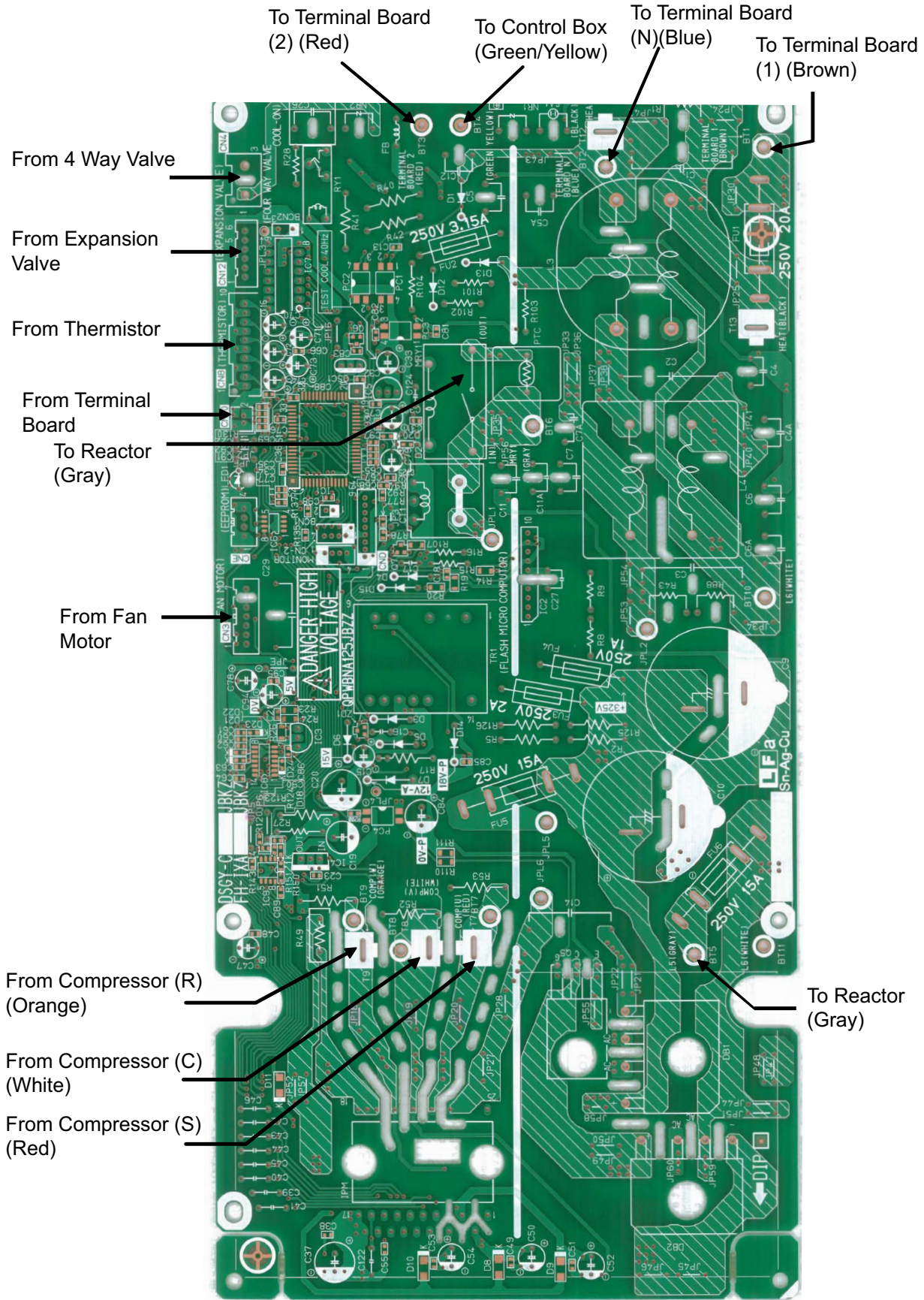

### [3] FUNCTION

#### 1. Function

##### 1.1. Restart control

Once the compressor stops operating, it will not restart for 180 seconds to protect the compressor.

Therefore, if the operating compressor is shut down from the remote control and then turned back on immediately after, the compressor will restart after a preset delay time.

(The indoor unit will restart operation immediately after the ON switch is operated on the remote control.)

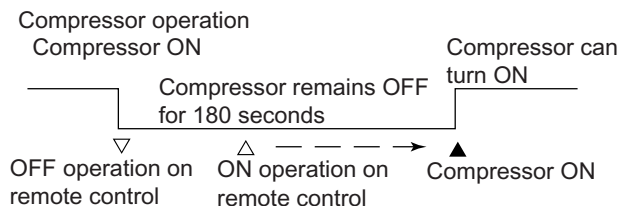

##### 1.2. Cold air prevention control

When the air to air heat pump starts up in heating mode, the indoor unit fan will not operate until the temperature of the indoor unit heat exchanger reaches about 23°C in order to prevent cold air from blowing into the room.

Also, the indoor unit fan operates at low speed until the temperature of the indoor unit heat exchanger reaches about 38°C so that people in the room will not feel chilly air flow.

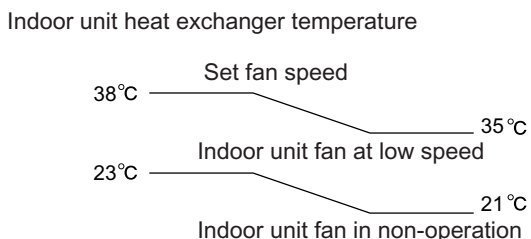

##### 1.3. Indoor unit heat exchanger freeze prevention control

If the temperature of the indoor unit heat exchanger remains below 0°C for 4 consecutive minutes during cooling or dehumidifying operation, the compressor operation stops temporarily in order to prevent freezing.

When the temperature of the indoor unit heat exchanger rises to 2°C or higher after about 180 seconds, the compressor restarts and resumes normal operation.

##### 1.4. Outdoor unit 2-way valve freeze prevention control

If the temperature of the outdoor unit 2-way valve remains below 0°C for 10 consecutive minutes during cooling or dehumidifying operation, the compressor operation stops temporarily in order to prevent freezing.

When the temperature of the 2-way valve rises to 10°C or higher after about 180 seconds, the compressor restarts and resumes normal operation.

##### 1.5. Indoor unit overheat prevention control

During heating operation, if the temperature of the indoor unit heat exchanger exceeds the indoor unit heat exchanger overheat prevention temperature (about 45 to 54°C) which is determined by the operating frequency and operating status, the operating frequency is decreased by about 4 to 15 Hz. Then, this operation is repeated every 60 seconds until the temperature of the indoor unit heat exchanger drops below the overheat protection temperature.

Once the temperature of the indoor unit heat exchanger drops below the overheat protection temperature, the operating frequency is increased by about 4 to 10 Hz every 60 seconds until the normal operation condition resumes.

If the temperature of the indoor unit heat exchanger exceeds the overheat protection temperature for 60 seconds at minimum operating frequency, the compressor stops operating and then restarts after about 180 seconds, and the abovementioned control is repeated.

##### 1.6. Outdoor unit overheat prevention control

During cooling operation, if the temperature of the outdoor unit heat exchanger exceeds the outdoor unit heat exchanger overheat prevention temperature (about 55°C), the operating frequency is decreased by about 4 to 15 Hz. Then, this operation is repeated every 60 seconds until the temperature of the outdoor unit heat exchanger drops to about 54°C or lower.

Once the temperature of the outdoor unit heat exchanger drops to about 54°C or lower, the operating frequency is increased by about 4 to 10 Hz every 60 seconds until the normal operation condition resumes.

If the temperature of the outdoor unit heat exchanger exceeds the outdoor unit heat exchanger overheat protection temperature for (120 sec : outdoor temperature ≥ 40°C • 60 sec : outdoor temperature < 40°C) at minimum operating frequency, the compressor stops operating and then restarts after about 180 seconds, and the abovementioned control is repeated.

##### 1.7. Compressor overheat prevention control

If the temperature of the compressor exceeds the compressor overheat prevention temperature (110°C), the operation frequency is decreased by about 4 to 10 Hz. Then, this operation is repeated every 60 seconds until the temperature of the compressor drops below the overheat protection temperature (100°C).

Once the temperature of the compressor drops below the overheat protection temperature, the operating frequency is increased by about 4 to 10 Hz every 60 seconds until the normal operation condition resumes.

If the temperature of the compressor exceeds the overheat protection temperature (for 120 seconds in cooling operation or 60 seconds in heating operation) at minimum operating frequency, the compressor stops operating and then restarts after about 180 seconds, and the abovementioned control is repeated.

##### 1.8. Startup control

When the air to air heat pump starts in the cooling or heating mode, if the room temperature is 2°C higher than the set temperature (in cooling operation) or 3.5°C lower (in heating operation), the air to air heat pump operates with the operating frequency at maximum. Then, when the set temperature is reached, the air to air heat pump operates at the operating frequency determined by fuzzy logic calculation, then enters the normal control mode after a while.



# 12KHR-N

## 1.9. Peak control

If the current flowing in the air to air heat pump exceeds the peak control current the operation frequency is decreased until the current value drops below the peak control current regardless of the frequency control demand issued from the indoor unit based on the room temperature.

## 1.10. Outdoor unit fan delay control

The compressor stops immediately after cooling, dehumidifying or heating operation is shut down, but the outdoor unit fan continues operation for 50 seconds before it stops.

## 1.11. Defrosting

### 1.11.1 Reverse defrosting

The defrost operation starts when the compressor operating time exceeds 20 minutes during heating operation, as shown below, and the outside air temperature and the outdoor unit heat exchanger temperature meet certain conditions. When the defrost operation starts, the indoor unit fan stops. The defrost operation stops when the outdoor unit heat exchanger temperature rises to about 13°C or higher or the defrosting time exceeds 10 minutes.

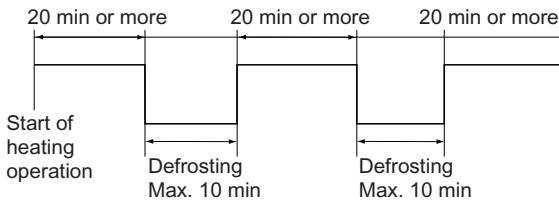

## 1.12. ON timer

The ON timer can be activated by pressing the ON timer button. When the ON timer is activated, the operation start time is adjusted based on fuzzy logic calculations 1 hour before the set time so that the room temperature reaches the set temperature at the set time.

## 1.13. OFF timer

The OFF timer can be activated by pressing the OFF timer button. When the OFF timer is set, the operation stops after the set time.

When this timer is set, the compressor operating frequency lowers for quieter operation, and the room temperature is gradually varied after one hour (reduced 1°C three times (max. 3°C) in heating, or increased 0.3°C three times (max. 1°C) in cooling or dehumidifying operation) so that the room temperature remains suitable for comfortable sleeping.

### Heating operation

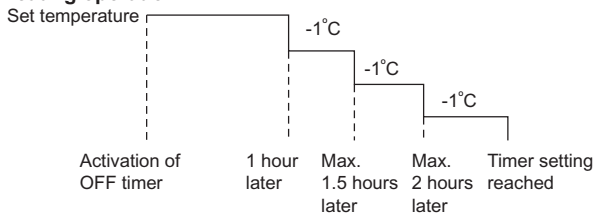

### Cooling/dehumidifying operation

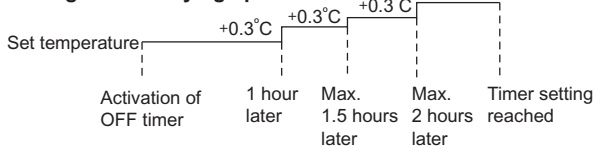

## 1.14. Power ON start

If a jumper cable is inserted in the location marked with HAJP on the indoor unit control printed circuit board (control PCB), connecting the power cord to an AC outlet starts the air to air heat pump in either cooling or heating mode, which is determined automatically by the room temperature sensor.

When a circuit breaker is used to control the ON/OFF operation, please insert a jumper as described above.

## 1.15. Self-diagnostic malfunction code display

### 1.15.1 Indoor unit

1) When a malfunction is confirmed, a flashing malfunction code number is displayed to indicate the type of malfunction.

When the air to air heat pump is in non-operating condition, holding down AUX button for more than 5 seconds activates the malfunction code display function.

The operation continues only in the case of a serial open-circuit, and the main relay turns off after 30 seconds if the open-circuit condition remains.

In the case of a serial short-circuit, the air to air heat pump continues operating without a malfunction code display.

The malfunction information is stored in memory, and can be recalled later and shown on display.

2) The self-diagnostic memory can be recalled and shown on the display by stopping the operation and holding down AUX button for more than 5 seconds.

3) The content of self-diagnosis (malfunction mode) is indicated by a flashing number.

(For details, refer to the troubleshooting section.)

### 1.15.2 Outdoor unit

If a malfunction occurs, LED1 on the outdoor unit flashes in 0.2-second intervals as shown below.

#### (Example) Compressor high temperature abnormality

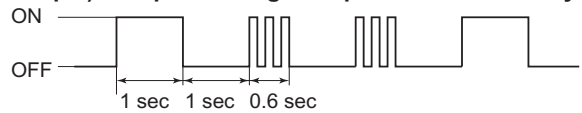

## 1.16. Information about auto mode

In the AUTO mode, the temperature setting and mode are automatically selected according to the room temperature and outdoor temperature when the unit is turned on.

### Modes and Temperature Settings

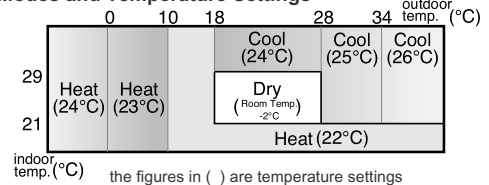

During operation, if the outdoor temperature changes, the temperature settings will automatically slide as shown in the chart.

1.17. Adjusting the air flow direction

1.17.2 Horizontal air flow direction

1.17.1 Vertical air flow direction

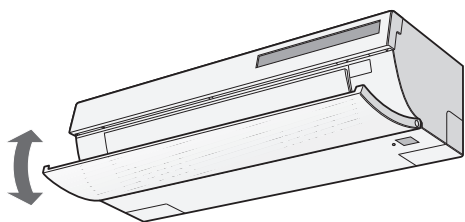

1 Press the VERTICAL AIR FLOW button to set the desired air flow direction.

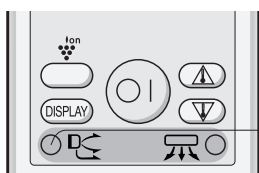

**AUTO mode**

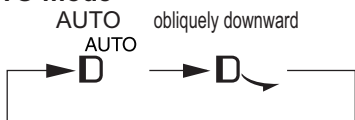

**HEAT mode**

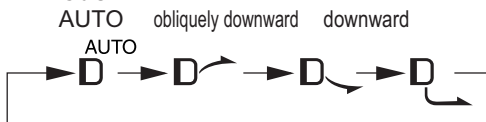

**COOL/DRY mode**

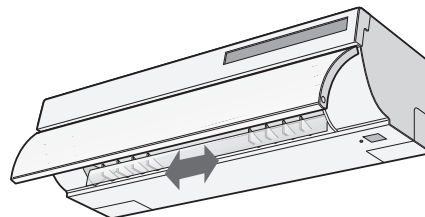
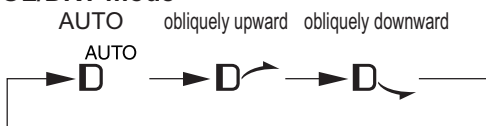

1 Press the HORIZONTAL AIR FLOW button to set the desired air flow direction

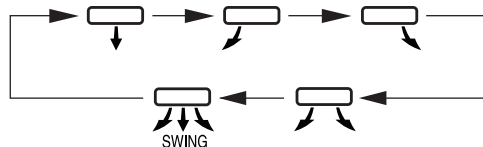
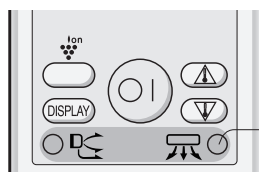

**CAUTION:**

Never attempt to adjust the open panel and the louvres manually.

- Manual adjustment of the open panel and the louvres can cause the unit to malfunction.

**TIPS ABOUT AIR FLOW DIRECTION “AUTO”**

**COOL mode**

The open panel will be set obliquely downward for 10 minutes, and then shift to obliquely upward to deliver cool air to the ceiling.

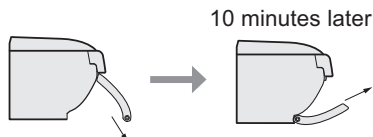

**HEAT mode**

The open panel will be set obliquely backward when outlet air temperature is low, and then shift to obliquely downward when outlet air becomes warm.

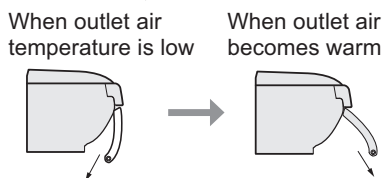

**DRY mode**

The open panel will be set obliquely upward.

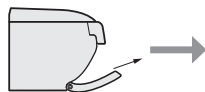

# 12KHR-N

## 1.18. Difference of operation in Auto and Manual modes

In the Auto mode, the temperature setting is automatically determined based on the outside air temperature. In addition, the air to air heat pump operation differs from the operation in the Manual mode as explained below.

### 1.18.1 Difference relating to set temperature

	Auto mode			Manual mode		
	Cooling	Heating	Dehumidifying	Cooling	Heating	Dehumidifying
Temperature setting method	Automatic temperature setting based on outside air temperature. Can be changed within $\pm 2^{\circ}\text{C}$ using remote control.			Can be changed between 18 and 32 $^{\circ}\text{C}$ using remote control.	Can be changed between 18 and 32 $^{\circ}\text{C}$ using remote control.	Automatic setting. Can be changed within $\pm 2^{\circ}\text{C}$ .

### 1.19. Dehumidifying operation control

If the room temperature is 26 $^{\circ}\text{C}$  or higher when dehumidifying operation starts, the dehumidifying operation provides a low cooling effect in accordance with the room temperature setting automatically determined based on the outside air operation. (The setting value is the same as the set temperature for cooling operation in the auto mode.)

If the room temperature is lower than 26 $^{\circ}\text{C}$  when dehumidifying operation starts, the dehumidifying operation minimizes the lowering of the room temperature.

ZONE	COM-PRESSOR	FAN	
Hot keep (When room temperature reaches setting temperature)	OFF	AUTO	Ultra soft (Lower than Fan speed "soft")
		SOFT LOW HIGH	Keep the setting

### 1.20. Self Clean operation

Heating or Fan operation and Cluster operation are performed simultaneously.

The judgment of whether Heating or Fan operation is used is based on the outside air temperature at 3 minutes after the start of internal cleaning.

The operation stops after 40 minutes. (The air to air heat pump shows the remaining minutes: 40  $\rightarrow$  39  $\rightarrow$  38 ... 3  $\rightarrow$  2  $\rightarrow$  1)

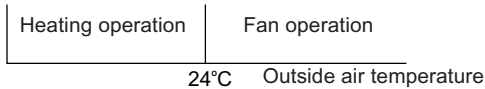

### 1.21. Plasmacluster Ion function

The Plasmacluster Ion generator inside the air conditioner will release positive and negative plasmacluster ions into the room. Approximately the same numbers of positive and negative ions released into the air will reduce some airborne mold.

During operation, press the PLASMACLUSTER button.

- The remote control will display "❄️".
- The blue PLASMACLUSTER lamp on the unit will light up.

#### TO CANCEL

Press the PLASMACLUSTER button again.

- The PLASMACLUSTER lamp on the unit will turn off.

NOTE: • Use of the PLASMACLUSTER operation will be memorized, and it will be activated the next time you turn on the air conditioner.

- To turn off the PLASMACLUSTER lamp, press the DISPLAY button.
- To perform the PLASMACLUSTER operation in FAN only mode, press the PLASMACLUSTER button while the unit is not operating. The mode symbol of the remote control will go off and the fan speed can not be set to AUTO.

### 1.22. Hot keep

If the room temperature is in the Hot keep zone during heating, the compressor is turned off to prevent overheating.



### 1.23. Winter cool

Cooling operation is available during the winter season by the built in winter cool function.

Lower limit of outdoor temperature range is -10 $^{\circ}\text{C}$  DB.

When the outside air temperature is low, the outdoor unit fan operates at slower speed.

NOTE: Built-in protect device may work when outdoor temperature falls below 21 $^{\circ}\text{C}$  DB., depending on conditions.

### 1.24. 10°C OPERATION

Heating operation with 10 $^{\circ}\text{C}$  set temperature will be performed.

- 1) Press the MODE button of Remote controller and select HEAT mode.
- 2) Press the ON / OFF button to start HEAT operation.
- 3) Press the 10 $^{\circ}\text{C}$  button.
  - The remote control will display 10 $^{\circ}\text{C}$ .

#### TO CANCEL

Press the 10 $^{\circ}\text{C}$  button again.

- 10 $^{\circ}\text{C}$  operation will also be cancelled when the operation mode is changed, or when the unit is turned off.

#### NOTE:

- 10 $^{\circ}\text{C}$  operation will not be available with heating operation automatically selected by AUTO mode.

### 1.25. Auto restart

When power failure occurs, after power is recovered, the unit will automatically restart in the same setting which were active before the power failure.

#### 1.25.1 Operating mode (Cool, Heat, Dry)

- Temperature adjustment (within 2 $^{\circ}\text{C}$  range) automatic operation
- Temperature setting
- Fan setting
- Air flow direction



- Power ON/OFF
- Automatic operation mode setting
- Swing louvre
- Plasmacluster mode

- Full power setting
- Internal cleaning

**1.25.2 Setting not memorized**

- Timer setting

**1.25.3 Disabling auto restart function**

By removing (cutting) jumper 8 (JP8) on the printed circuit board (PCB), the auto restart function can be disabled.

**2. Explanation of cluster circuit**

The cluster unit generates cluster ions, which are circulated throughout the room by the air flow created by the blower fan (indoor unit fan motor) in the air to air heat pump unit.

1) When microcomputer output turns "H," the IC13 output changes to "Lo," turning ON the SSR1 and applying 100 V to the cluster unit for the generation of cluster ions (positive and negative ions).

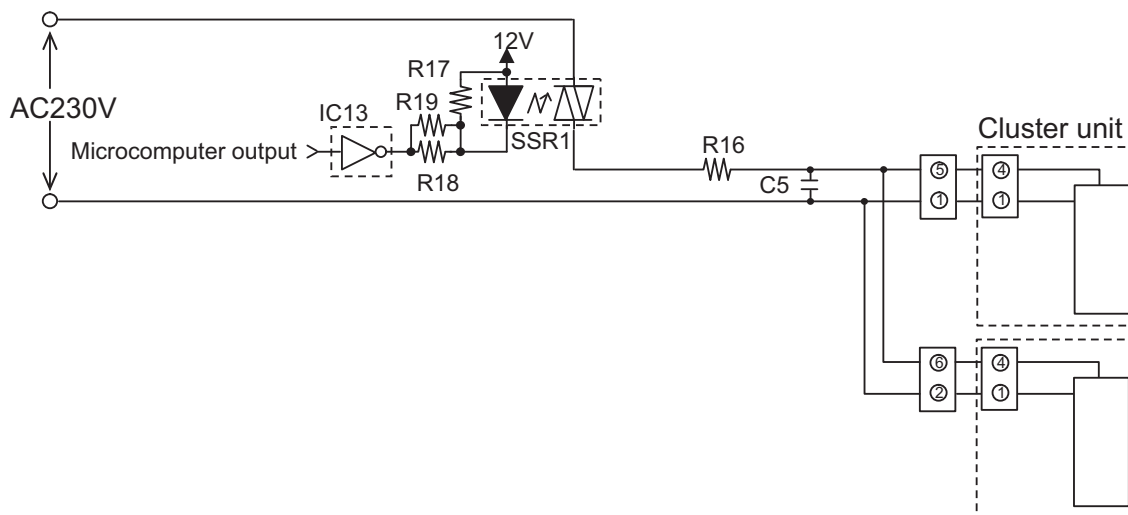

**3. Outline of PAM circuit**

**3.1. PAM (Pulse Amplitude Modulation)**

The PAM circuit varies the compressor drive voltage and controls the rotation speed of the compressor.

The IGBT shown in the block diagram charges the energy (electromotive force) generated by the reactor to the electrolytic capacitor for the inverter by turning ON and OFF.

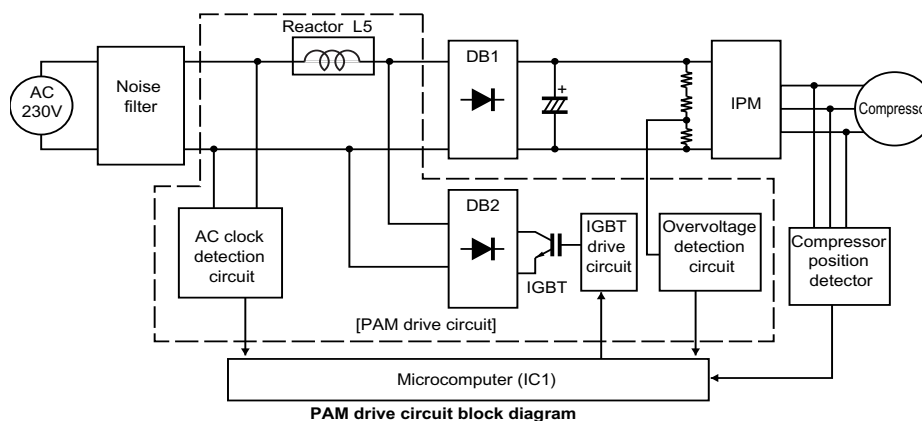

When the IGBT is ON, an electric current flows to the IGBT via the reactor (L5) and diode bridge (DB2).

When the IGBT turns OFF, the energy stored while the IGBT was ON is charged to the voltage doubler capacitor via the diode bridge (DB1).

As such, by varying the ON/OFF duty of the IGBT, the output voltage is varied.

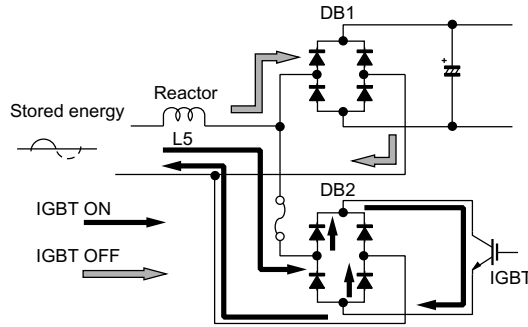

**3.2. High power factor control circuit**

This circuit brings the operating current waveform closer to the waveform of commercial power supply voltage to maintain a high power factor. Because of the capacitor input, when the PAM circuit is OFF, the phase of the current waveform deviates from the voltage waveform as shown below. To prevent this deviation, a current is supplied during the periods indicated by "O" in the diagram. To determine the length of period to supply a current, the zero-cross timing of the AC input voltage is input to the microcomputer via the clock circuit. The power source frequency is also determined at the same time. The IGBT turns ON after the time length determined by the zero-cross point to supply a current to the IGBT via the reactor. This brings the current waveform closer to the voltage waveform in phase. As described above, the ON/OFF operation of the IGBT controls the increase/decrease of the compressor power supply voltage (DC voltage) to improve the compressor efficiency and maintain a high power factor by keeping the current phase closer to that of the supply voltage.

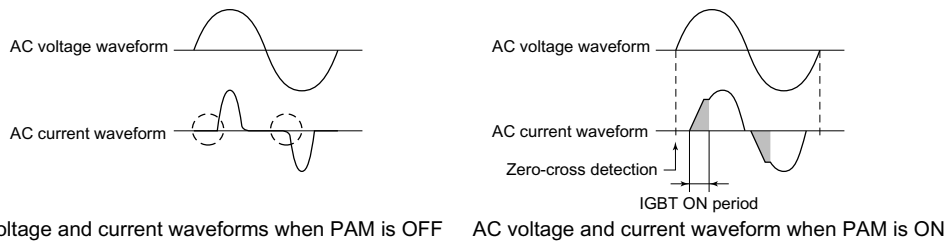

**3.2.1 Detailed explanation of PAM drive circuit sequence**

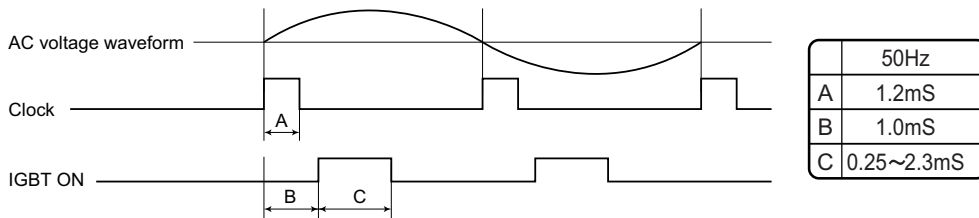

**3.2.2 AC clock (zero-cross) judgment**

- The clock circuit determines the time from one rising point of the clock waveform to the next rising point. The detected clock waveform is used to judge the power source frequency (50 Hz).
- The zero-cross of the AC voltage is judged as the rising of the clock waveform, as shown in the diagram above.

**3.2.3 IGBT ON start time (delay time B)**

- Based on the zero-cross of the AC voltage, the IGBT turns ON after a delay time set according to the power source frequency.

**3.2.4 IGBT ON time (C)**

- After the above delay time, the IGBT turns ON to supply a current to the reactor.
- The ON time of the IGBT determines the amount of energy (level of DC voltage rise) supplied to the reactor. DC voltage level in each operation mode (varies depending on external load conditions)
  - Cooling operation --- 260 to 280 V
  - Heating operation --- 260 to 290 V



**4. Explanation of IPM drive circuit**

The IPM for compressor drive is made by Mitsubishi Electric.

The power supply for the IPM drive and the shunt resistance for overcurrent detection, are provided outside the IPM.

**4.1. IPM drive power supply circuit**

The power supply for the upper-phase IGBT (HU, HV, HW) drive employs a bootstrap system, and provides power to the upper-phase IC.

The 15-V power supply for the lower-phase IC is provided by the control printed circuit board (PCB).

**4.1.1 Brief explanation of bootstrap system (single power drive system)**

To supply power to the upper-phase IC, the microcomputer (IC1) turns ON the lower-phase IGBT (LU, LV, LW).

This results in a charging current that flows to the electrolytic capacitor of each upper-phase IC input and charges the bootstrap capacitor with a 15-V current.

The power supply for the subsequent stages is charged while the lower-phase IGBT is ON in ordinary compressor drive control.

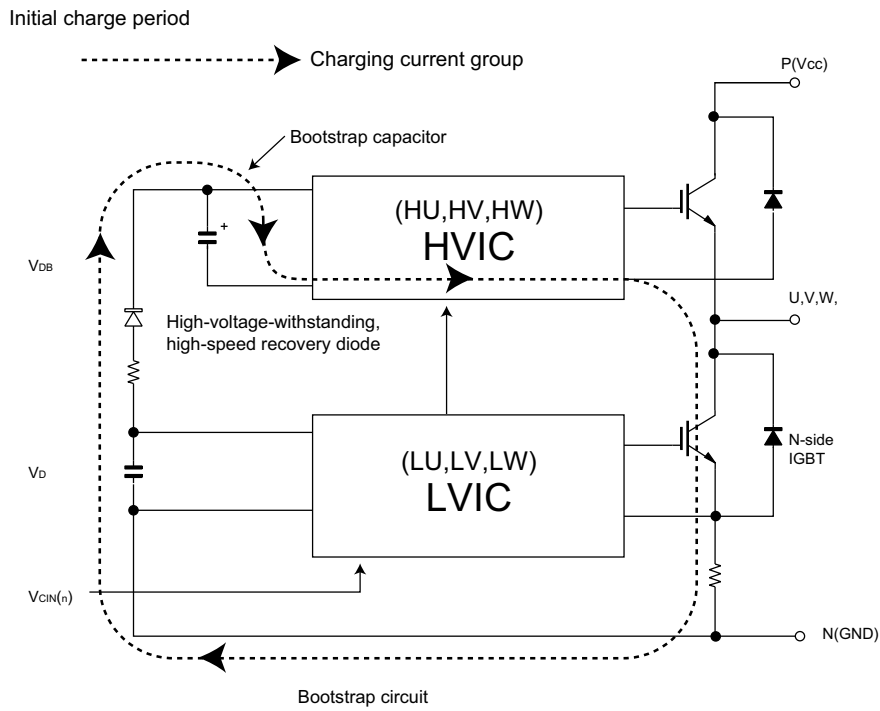

### 4.1.2 DC overcurrent detection circuit

When a current of about 25 A or higher flows through the shunt resistance (R49) on the control printed circuit board (PCB), the voltage at this resistance is input to IPM CIN pin (15). Then, the gate voltage of the lower-phase IGBT (LU, LV, LW) inside the IPM turns OFF to cut off the overcurrent. At the same time, an L output of more than 20μs. is generated from IPM Fo pin (14), and this results in an L input to overcurrent detection input pin (34) of the microcomputer (IC1) and turns OFF the PWM signal output (IC1 pins (51) through (56)) to the IGBT gate.

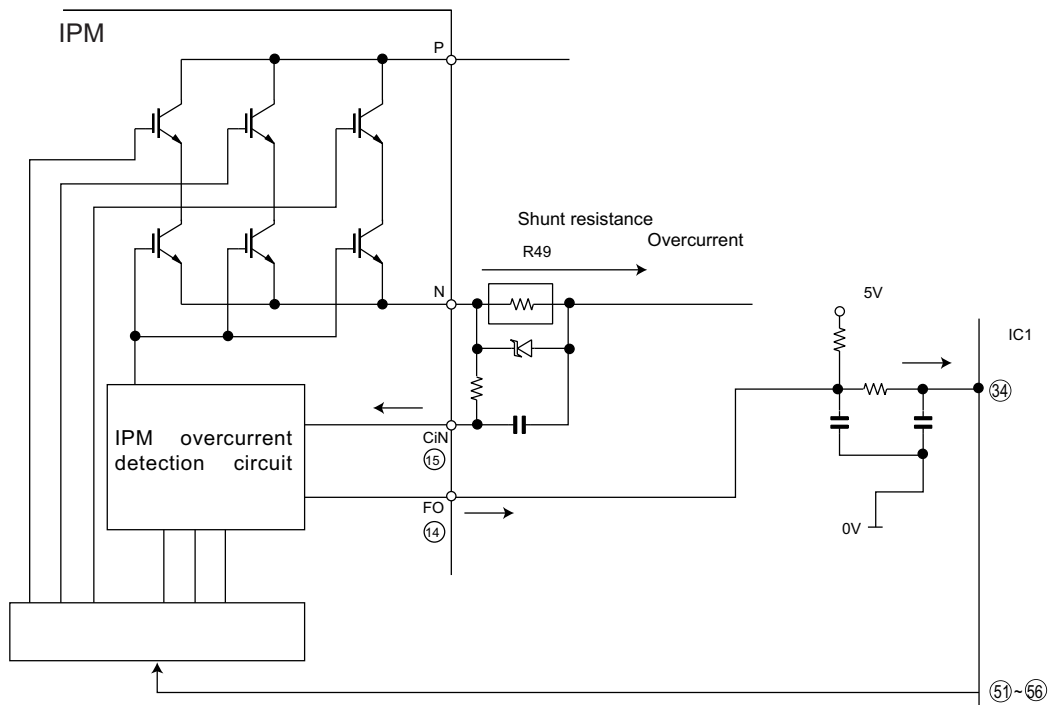
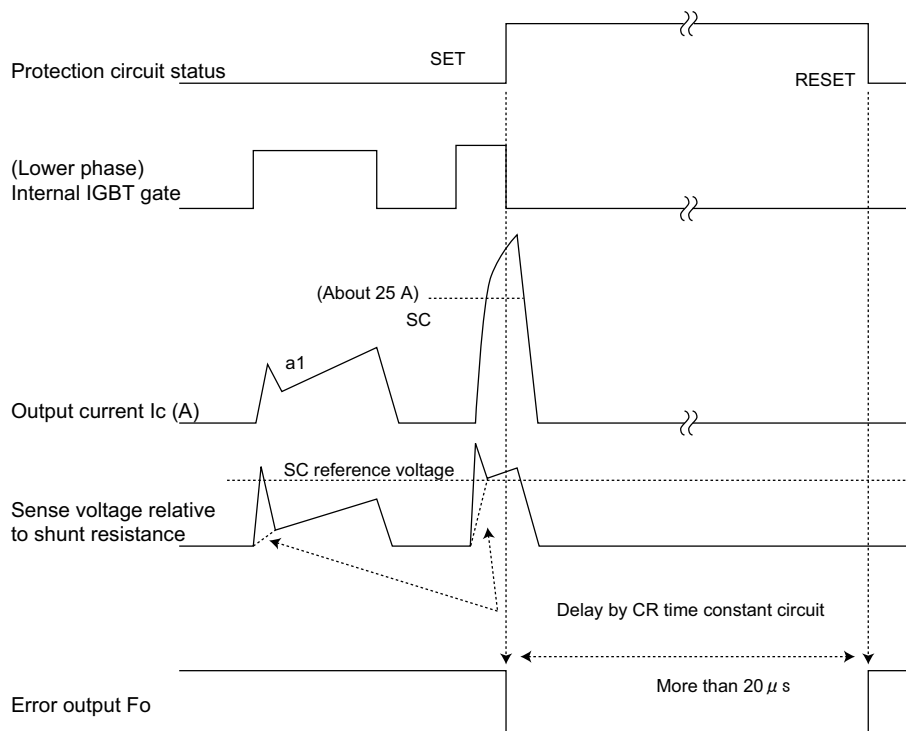

**5. 120° energizing control (digital position detection control)**

This control system detects the digital position detection signal and adjusts the rate of acceleration/deceleration accordingly.

The motor's induced voltage waveform is input to the comparator in the form of PWM-switched pulse waveform, and a position detection signal is generated as a reference voltage equaling 1/2 of 280 VDC. However, since there is no induced voltage waveform when the PWM waveform is OFF, the microcomputer performs internal processing so that detection is enabled only when it is ON. Based on the detected position signal, actual PWM waveform output timing is determined. Since it does not use a filter circuit, the detection accuracy is high.

The microcomputer performs internal processing to cancel spike voltage during the regenerative process.

Furthermore, even if the induced voltage is low, position detection is still possible, thus allowing sensor-less operation at low rotation speed in the initial stage of operation. This reduces the starting current and improves the IPM reliability.

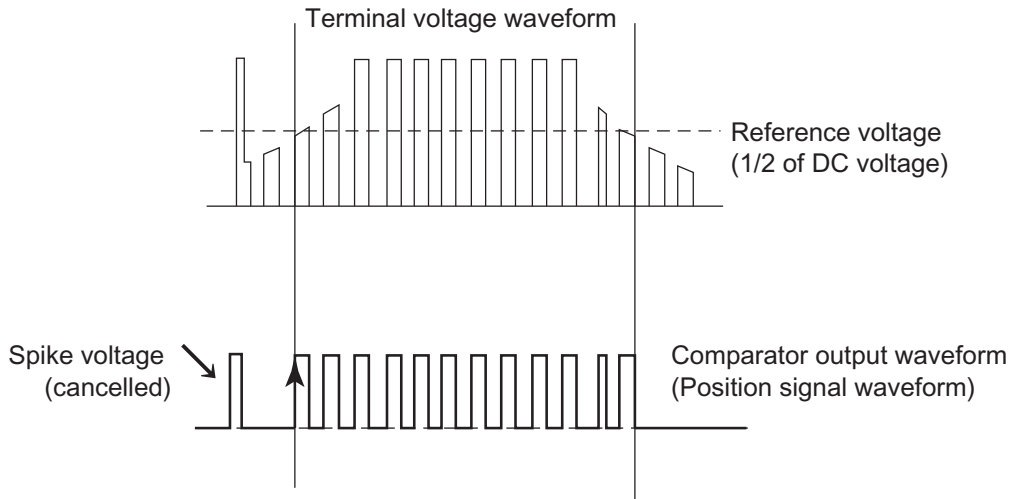

**6. 180° Energizing Control**

This is the control system to moderate the speed by the current phase difference for higher efficiency and lower noise of the compressor. The current phase difference control is the control system paid attention to the interrelation between efficiency and phase gap generated by the applied voltage of motor and current in the coil of motor as shown in the figure below.

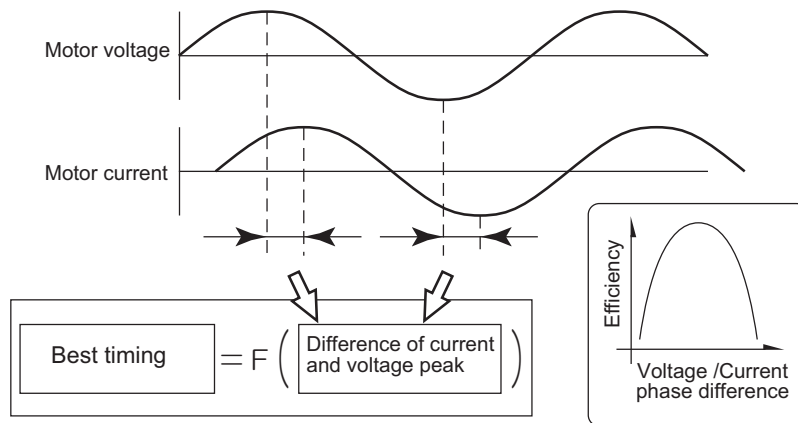

Concept chart of the current phase difference control

This control is the V/F drive system independent of the location of rotor, detecting the phase difference between driving voltage phase and line current phase flowing in motor coil, and controls the modulation rate data to get the phase difference at the best efficiency.

## CHAPTER 3. FUNCTION AND OPERATION OF PROTECTIVE PROCEDURES

### [1] PROTECTION DEVICE FUNCTIONS AND OPERATIONS

Function		Operation				Self-diagnosis result display	
		Description	Detection period	Reset condition	Indoor unit error display	Indoor unit	Outdoor unit
1	Indoor unit fan lock	Operation stops if there is no input of rotation pulse signal from indoor unit fan motor for 1 minute.	When indoor unit fan is in operation	Operation OFF or ON	☆2	Yes	None
	Indoor unit fan rotation speed error	Operation stops if rotation pulse signal from indoor unit fan indicates abnormally low speed (about 300 rpm or slower).	When indoor unit fan is in operation	Operation OFF or ON	☆2	Yes	None
2	Indoor unit freeze prevention	Compressor stops if temperature remains below 0°C for 4 minutes.	When in cooling or dehumidifying operation	Automatic reset when heat exchanger temperature rises above freeze prevention temperature (2°C or higher)	—	None	None
3	2-way valve freeze prevention	Compressor stops if temperature of outdoor unit 2-way valve remains below 0°C for 10 continuous minutes during cooling or dehumidifying operation.	When in cooling or dehumidifying operation	Automatic reset when temperature of 2-way valve rises above 10°C.	None	Yes	Yes
4	Indoor unit heat exchanger overheat shutdown	Operating frequency lowers if indoor unit heat exchanger temperature exceeds overheat temperature during heating operation. Compressor stops if indoor unit heat exchanger temperature exceeds overheat temperature for 60 seconds at minimum frequency. Overheat temperature setting value indoor unit heat exchanger thermistor temperature: about 45 to 54°C	When in heating operation	Automatic reset after safety period (180 sec).	None	Yes	Yes
5	Outdoor unit heat exchanger overheat shutdown	Operation frequency lowers if outdoor unit heat exchanger temperature exceeds about 55°C during cooling operation. Compressor stops if outdoor unit heat exchanger temperature exceeds about 55°C for 120 seconds at minimum frequency.	When in cooling or dehumidifying operation	Automatic reset after safety period (180 sec).	None	Yes	Yes
6	Compressor discharge overheat shutdown	Operating frequency lowers if temperature of compressor chamber thermistor (TH1) falls below about 110°C. Compressor stops if temperature of compressor chamber thermistor (TH1) remains at about 110°C (for 120 seconds in cooling operation, or 60 seconds in heating operation) at minimum frequency.	When compressor is in operation	Automatic reset after safety period (180 sec).	None	Yes	Yes
7	Dehumidifying operation temporary stop	Compressor stops if outside air temperature thermistor is lower than about 16°C during dehumidifying operation.	When in dehumidifying operation	Automatic reset when outside air temperature rises above 16°C.	None	Yes	Yes
8	DC overcurrent error	Compressor stops if DC current of about 25 A or higher flows in IPM.	When compressor is in operation	Operation OFF or ON	Yes ☆1	Yes	Yes

Function	Operation				Self-diagnosis result display		
	Description	Detection period	Reset condition	Indoor unit error display	Indoor unit	Outdoor unit	
9	AC overcurrent error	Operating frequency lowers if outdoor AC current exceeds peak control current value. outdoor stops if compressor AC current exceeds peak control current value at minimum frequency.	When compressor is in operation	Operation OFF or ON	Yes ☆1	Yes	Yes
10	AC overcurrent error in compressor OFF status	Indoor and outdoor units stop if outdoor AC current exceeds about 3 A while compressor is in non-operation status.	When compressor is in non-operation	Replacement of defective parts such as IPM	Yes ☆2	Yes	Yes
11	AC maximum current error	Compressor stops if outdoor AC current exceeds 17 A.	When compressor is in operation	Operation OFF or ON	Yes ☆1	Yes	Yes
12	AC current deficiency error	Compressor stops if operating frequency is 50 Hz or higher and outdoor AC current is about 2.0 A or lower.	When compressor is in operation	Operation OFF or ON	Yes ☆1	Yes	Yes
13	Thermistor installation error or 4-way valve error	Compressor stops if high and low values of temperatures detected by outdoor unit heat exchanger thermistor (TH2) and 2-way valve thermistor (TH5) do not match operating cycle.	3 minutes after compressor startup	Operation OFF or ON	Yes ☆1	Yes	Yes
14	Compressor high temperature error	Compressor stops if compressor chamber thermistor (TH1) exceeds about 114°C, or if there is short-circuit in TH1.	When in operation	Operation OFF or ON	Yes ☆1	Yes	Yes
15	Outdoor unit heat exchanger thermistor short-circuit error	Compressor stops if there is short-circuit in outdoor unit heat exchanger thermistor (TH2).	At compressor startup	Operation OFF or ON	Yes ☆1	Yes	Yes
16	Outdoor unit outside air temperature thermistor short-circuit error	Compressor stops if there is short-circuit in outdoor unit outside air temperature thermistor (TH3).	At compressor startup	Operation OFF or ON	Yes ☆1	Yes	Yes
17	Outdoor unit suction thermistor short-circuit error	Compressor stops if there is short-circuit in outdoor unit suction thermistor (TH4).	At compressor startup	Operation OFF or ON	Yes ☆1	Yes	Yes
18	Outdoor unit 2-way valve thermistor short-circuit error	Compressor stops if there is short-circuit in outdoor unit 2-way valve thermistor (TH5).	At compressor startup	Operation OFF or ON	Yes ☆1	Yes	Yes
19	Outdoor unit heat exchanger thermistor open-circuit error	Compressor stops if there is open-circuit in outdoor unit heat exchanger thermistor (TH2).	At compressor startup	Operation OFF or ON	Yes ☆1	Yes	Yes
20	Outdoor unit outside air temperature thermistor open-circuit error	Compressor stops if there is open-circuit in outdoor unit outside air temperature thermistor (TH3).	At compressor startup	Operation OFF or ON	Yes ☆1	Yes	Yes
21	Outdoor unit suction thermistor open-circuit error	Compressor stops if there is open-circuit in outdoor unit suction thermistor (TH4).	At compressor startup	Operation OFF or ON	Yes ☆1	Yes	Yes
22	Outdoor unit 2-way valve thermistor open-circuit error	Compressor stops if there is open-circuit in outdoor unit 2-way valve thermistor (TH5).	At compressor startup	Operation OFF or ON	Yes ☆1	Yes	Yes
23	Outdoor unit discharge thermistor open-circuit error	Compressor stops if there is open-circuit in outdoor unit discharge thermistor (TH1).	At compressor startup	Operation OFF or ON	Yes ☆1	Yes	Yes
24	Serial signal error	Compressor stops if outdoor unit cannot receive serial signal from indoor unit for 30 seconds.	When in operation	Reset after reception of serial signal	None	None	None
25	Compressor start-up error	Compressor stops if compressor fails to start up.	At compressor start-up	Operation OFF or ON	Yes ☆3	Yes	Yes



Function		Operation				Self-diagnosis result display	
		Description	Detection period	Reset condition	Indoor unit error display	Indoor unit	Outdoor unit
26	Compressor rotation error (at 120° energizing)	Compressor stops if there is no input of position detection signal from compressor or input is abnormal.	Compressor operating at 120° energizing	Operation OFF or ON	Yes ☆3	Yes	Yes
27	Outdoor unit DC fan error	Operation stops if there is no input of rotation pulse signal from outdoor unit fan motor for 30 seconds.	When outdoor unit fan is in operation	Operation OFF or ON	Yes ☆1	Yes	Yes
28	PAM overvoltage error	Compressor stops if DC voltage is 400 V or higher.	When in operation	Operation OFF or ON	Yes ☆1	Yes	Yes
29	PAM clock error	When power source frequency cannot be determined (at startup), or when power source clock cannot be detected for 1 continuous second (at startup).	At compressor startup, when in operation	Compressor continues operation without stopping.	None	Yes	Yes

☆1—The outdoor unit restarts four times before the indoor unit error is displayed (complete shutdown).

☆2—A single error judgment results in the display of the indoor unit error (complete shutdown).

☆3—The outdoor unit restarts eight times before the indoor unit error is displayed (complete shutdown).

## [2] AIR TO AIR HEAT PUMP OPERATION IN THERMISTOR ERROR

### 1. Indoor unit

Item	Mode	Control operation	When resistance is low (temperature judged higher than actual)	Short-circuit	When resistance is high (temperature judged lower than actual)	Open-circuit
Room temperature thermistor (TH1)	Auto	Operation mode judgment	Cooling mode is activated even if room temperature is low.	Cooling mode is activated in most cases.	Heating mode is activated even if room temperature is high.	Heating mode is always activated.
	Cooling	Frequency control	Room becomes too cold.	Air conditioner operates in full power even when set temperature is reached.	Room does not become cool.	Compressor does not operate.
	Dehumidifying	Room temperature memory Frequency control	Normal operation.	Room temperature is stored in memory as 31.0°C, and compressor does not stop.	Normal operation.	Room temperature is stored in memory as 18.5°C, and compressor does not operate.
	Heating	Frequency control	Room does not become warm.	Hot keep status results immediately after operation starts. Frequency does not increase above 30 Hz (40 Hz).	Room becomes too warm.	Air conditioner operates in full power even when set temperature is reached.
Heat exchanger thermistor (TH2)	Cooling Dehumidifying	Freeze prevention	Indoor unit evaporator may freeze.	Indoor unit evaporator may freeze.	Compressor stops occasionally.	Compressor does not operate.
	Heating	Cold air prevention	Cold air prevention deactivates too soon and cold air discharges.	Compressor operates at low speed or stops, and frequency does not increase.	Cold air prevention deactivates too slow.	Cold air prevention does not deactivate, and indoor unit fan does not rotate.

## 2. Outdoor unit

Item	Mode	Control operation	When resistance is low (temperature judged higher than actual)	Short-circuit	When resistance is high (temperature judged lower than actual)	Open-circuit
Compressor chamber thermistor (TH1)	Cooling Dehumidifying Heating	Expansion valve control and compressor protection	Compressor operates, but room does not become cool or warm (expansion valve is open).	Compressor high temperature error indication.	Layer short-circuit or open-circuit may result in compressor in normal operation.	Outdoor unit thermistor open-circuit error indication.
Heat exchanger thermistor (TH2)	Cooling Dehumidifying	Outdoor unit heat exchanger overheat prevention	Compressor operates at low speed or stops.	Outdoor unit thermistor short-circuit error indication.	Normal operation.	Outdoor unit thermistor open-circuit error indication.
	Heating	Expansion valve control Defrosting	Defrosting operation is not activated as needed, and frost accumulates on outdoor unit (expansion valve is closed).	Outdoor unit thermistor short-circuit error indication.	Defrosting operation is activated unnecessarily, and room does not become warm (expansion valve is open).	Outdoor unit thermistor open-circuit error indication.
Outside air temperature thermistor (TH3)	Auto	Operation mode judgment	Cooling mode is activated even if room temperature is low.	Outdoor unit thermistor short-circuit error indication.	Heating mode is activated even if room temperature is high.	Outdoor unit thermistor open-circuit error indication.
	Cooling Dehumidifying	Operation not affected	Normal operation.	Outdoor unit thermistor short-circuit error indication.	Normal operation.	Outdoor unit thermistor open-circuit error indication.
	Heating	Rating control Defrosting	Defrosting operation is activated unnecessarily.	Outdoor unit thermistor short-circuit error indication.	Defrosting operation is not activated, and frost accumulates on outdoor unit.	Outdoor unit thermistor open-circuit error indication.
Suction pipe thermistor (TH4)	Cooling Dehumidifying	Expansion valve control	Compressor operates, but room does not become cool (expansion valve is open).	Outdoor unit thermistor short-circuit error indication.	Frost accumulates on evaporator inlet section, and room does not become cool (expansion valve is closed).	Outdoor unit thermistor open-circuit error indication.
	Heating	Expansion valve control	Compressor operates, but room does not become warm (expansion valve is open).	Outdoor unit thermistor short-circuit error indication.	Frost accumulates on expansion valve outlet section, and room does not become warm (expansion valve is closed).	Outdoor unit thermistor open-circuit error indication.
2-way valve thermistor (TH5)	Cooling Dehumidifying	Expansion valve control	Frost accumulates on indoor unit evaporator and room does not become cool (expansion valve is closed).	Outdoor unit thermistor short-circuit error indication.	Compressor operates, but room does not become cool (expansion valve is open).	Outdoor unit thermistor open-circuit error indication.
	Heating	Operation not affected	Normal operation.	Outdoor unit thermistor short-circuit error indication.	Normal operation.	Outdoor unit thermistor open-circuit error indication.

### [3] THERMISTOR TEMPERATURE CHARACTERISTICS

#### 1. Indoor unit thermistor temperature characteristics

Figure 1 Temperature properties of indoor thermistors

Thermistor	Signal	Color
Room temperature	TH1	Yellow
Heat exchange	TH2	Orange

Room temperature thermistor TH1 (CN10 ① - ③)  
Heat exchange thermistor TH2 (CN11 ① - ②)

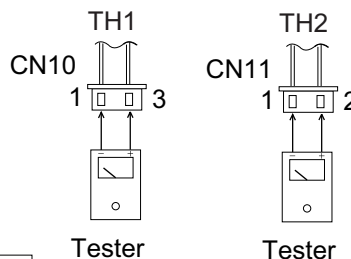
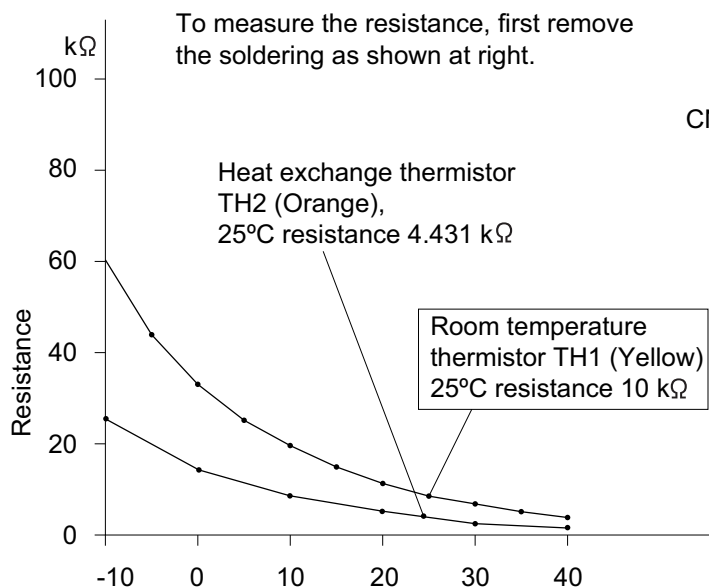

#### 2. Outdoor unit thermistor temperature characteristics

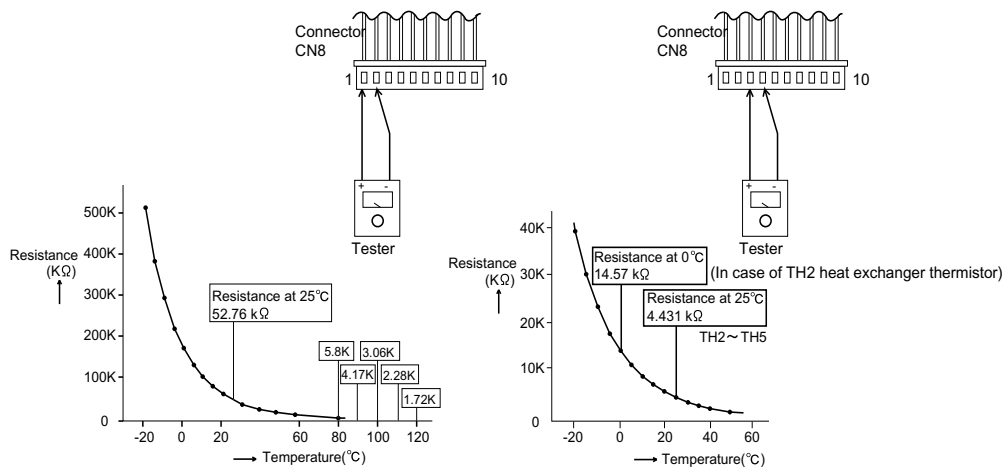

TH1 Compressor thermistor

TH2 Heat exchanger thermistor  
TH3 Outdoor air temperature thermistor  
TH4 Suction thermistor  
TH5 2-way valve thermistor

Thermistor	No.	Connector	Color
Compressor thermistor	TH1	No. (1) - No. (2)	Red
Heat exchanger thermistor	TH2	No. (3) - No. (4)	Orange
Outdoor air temperature thermistor	TH3	No. (5) - No. (6)	Green
Suction thermistor	TH4	No. (7) - No. (8)	Black
2-way valve thermistor	TH5	No. (9) - No. (10)	Yellow

Before measuring resistance, disconnect connectors from PWB.

## [4] HOW TO OPERATE THE OUTDOOR UNIT INDEPENDENTLY

### 1. Cooling in 40 Hz fixed mode

To operate the outdoor unit independently, short-circuit the sections indicated by arrows in the diagram below with an adapter, and apply 220-240 VAC between (1) and (N) on the terminal board of the outdoor unit. This allows the outdoor unit to be operated in cooling mode independently.

(Do not operate the outdoor unit in this condition for an extended period of time.)

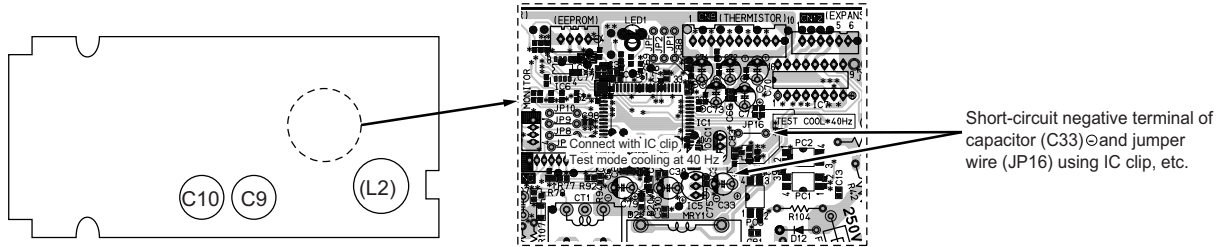

## [5] GENERAL TROUBLESHOOTING CHART

### 1. Indoor unit does not turn on

Main cause	Inspection method	Normal value/condition	Remedy
Cracked PWB. (Cracked pattern)	Check visually.	There should be no cracking in PWB or pattern.	Replace PWB.
Open-circuit in FU1 (250 V, 3.15 A)	Check melting of FU1.	There should be no open-circuit.	Replace PWB.

### 2. Indoor unit fan does not operate

Main cause	Inspection method	Normal value/condition	Remedy
Open-circuit in heat exchanger thermistor (TH2) (in heating operation)	Measure thermistor resistance (dismount for check).	-1	Replace thermistor.
		There should be no open-circuit or faulty contact.	Replace thermistor.
Disconnected heat exchanger thermistor (TH2) (in heating operation)	Inspect connector on PWB. Check thermistor installation condition.	Thermistor should not be disconnected.	Install correctly.

### 3. Indoor unit fan speed does not change

Main cause	Inspection method	Normal value/condition	Remedy
Remote control is not designed to allow fan speed change in several operation mode.	Check operation mode.	Fan speed should change except during dehumidifying operation, ventilation, light dehumidifying operation, internally normal operation	Explain to user.

### 4. Remote control signal is not received

Main cause	Inspection method	Normal value/condition	Remedy
Batteries at end of service life.	Measure battery voltage.	2.5 V or higher (two batteries in series connection)	Install new batteries.
Batteries installed incorrectly.	Check battery direction.	As indicated on battery compartment.	Install batteries in indicated direction.
Lighting fixture is too close, or Fluorescent lamp is flickering in the room.	Turn off light and check.	Signal should be received when light is turned off.	Change light position or install new fluorescent lamp.
Sevick light (Hitachi) is used in the room.	Check room lights.	Signal may not be received sometimes due to effect of Sevick light.	Replace light or change position.
Operating position/angle are inappropriate.	Operate within range specified in manual.	Signal should be received within range specified in manual.	Explain appropriate handling to user.
Open-circuit or short-circuit in wiring of light receiving section.	Check if wires of light receiving section are caught.	Wires of light receiving section should not have any damage caused by pinching.	Replace wires of light receiving section.
Light receiving unit is defective	Check signal receiving circuit (measure voltage between terminals 8 and 10, 9 and 10 of connector CN17).	Tester indicator should move when signal is received.	Replace PWB.

Main cause	Inspection method	Normal value/condition	Remedy
Dew condensation on light receiving unit.	Check for water and rust.	Signal should be received within range specified in manual.	Take moisture-proof measure for lead wire outlet of light receiving section.

### 5. Louvers do not move

Main cause	Inspection method	Normal value/condition	Remedy
Caught in sliding section.	Operate to see if louvers are caught in place.	Louvers should operate smoothly.	Remove or correct catching section.
Disconnected connector (CN13, CN16, CN19) on relay PWB, louver motor side)	Inspect connectors.	Connectors or pins should not be disconnected.	Install correctly.
Contact of solder on PWB (connector section on PWB)	Check visually.	There should not be solder contact.	Correct contacting section.

### 6. There is noise in TV/radio

Main cause	Inspection method	Normal value/condition	Remedy
Grounding wires not connected properly.	Check grounding wire connections.	Grounding wires should be connected properly.	Connect grounding wires properly.
TV/radio is placed too close to outdoor unit.	Check distance between TV/radio and outdoor unit.	If TV/radio is placed too close, it may become affected by noise.	Move TV/radio away from outdoor unit.
Other than above.	Check for radio wave interference.		

### 7. Malfunction occurs

Main cause	Inspection method	Normal value/condition	Remedy
Malfunction caused by noise.	Check for radio wave interference.		

### 8. Compressor does not start

Main cause	Inspection method	Normal value/condition	Remedy
Erroneous inter-unit connection.	Check wiring between indoor and outdoor units.	Terminal board 1-N: 220-240 VAC, 50 Hz Terminal board 2: serial signal	Correct wiring.
Damaged IPM.	Check IPM continuity.	See [IPM check method] on page 3-10	Replace IPM.
Dried-up electrolytic capacitor.	Check electrolytic capacitor.	See [Inverter electrolytic capacitor (C9,C10) check method] on page 3-9	Replace electrolytic capacitor.
Blown outdoor unit fuse.	Check 20A fuse. Check 15A fuse.	Fuse should not be blown.	Replace fuse/diode bridge. Replace fuse. Replace outdoor unit PWB assembly.
Power supply voltage is too low.	Measure power supply voltage during startup.	230±10 VAC, 50 Hz	Make sure that power supply voltage is 200 V or higher.
Compressor lock.  •Temp. fuse of terminal is error •EEPROM error •AC Over current error	Supply current and touch compressor cover (sound absorbing material) to check if operation starts.  See (Diagnosis Function and display mode) on page 3-13	Compressor should start normally.  Malfunction display section (0-0) Compressor should start normally.	Apply external impact to compressor. Replace compressor.  •Replace terminal •Replace outdoor unit PWB •Replace outdoor unit PWB

### 9. Operation stops after a few minutes and restarts, and this process repeats

Main cause	Inspection method	Normal value/condition	Remedy
Dried-up electrolytic capacitor.	Measure 320VDC line voltage.	300 V or higher.	Replace electrolytic capacitor.
Layer short-circuit in expansion valve coil.	Measure resistance.	46±3Ω in each phase (at 20°C)	Replace coil.

CAUTION: If fuse FU1/FU4/FU5 (outdoor unit control circuit board) is blown, be careful of charging voltage in inverter electrolytic capacitor C9, C10.

To discharge stored electricity, unplug the power cord and connect the plug of a soldering iron (230VAC, 50W) between the positive and negative terminals of inverter electrolytic capacitor C9, C10.

**[6] MALFUNCTION (PARTS) CHECK METHOD**

**1. Procedure for determining defective outdoor unit IPM/compressor**

The following flow chart shows a procedure for locating the cause of a malfunction when the compressor does not start up and a DC overcurrent indication error occurs.

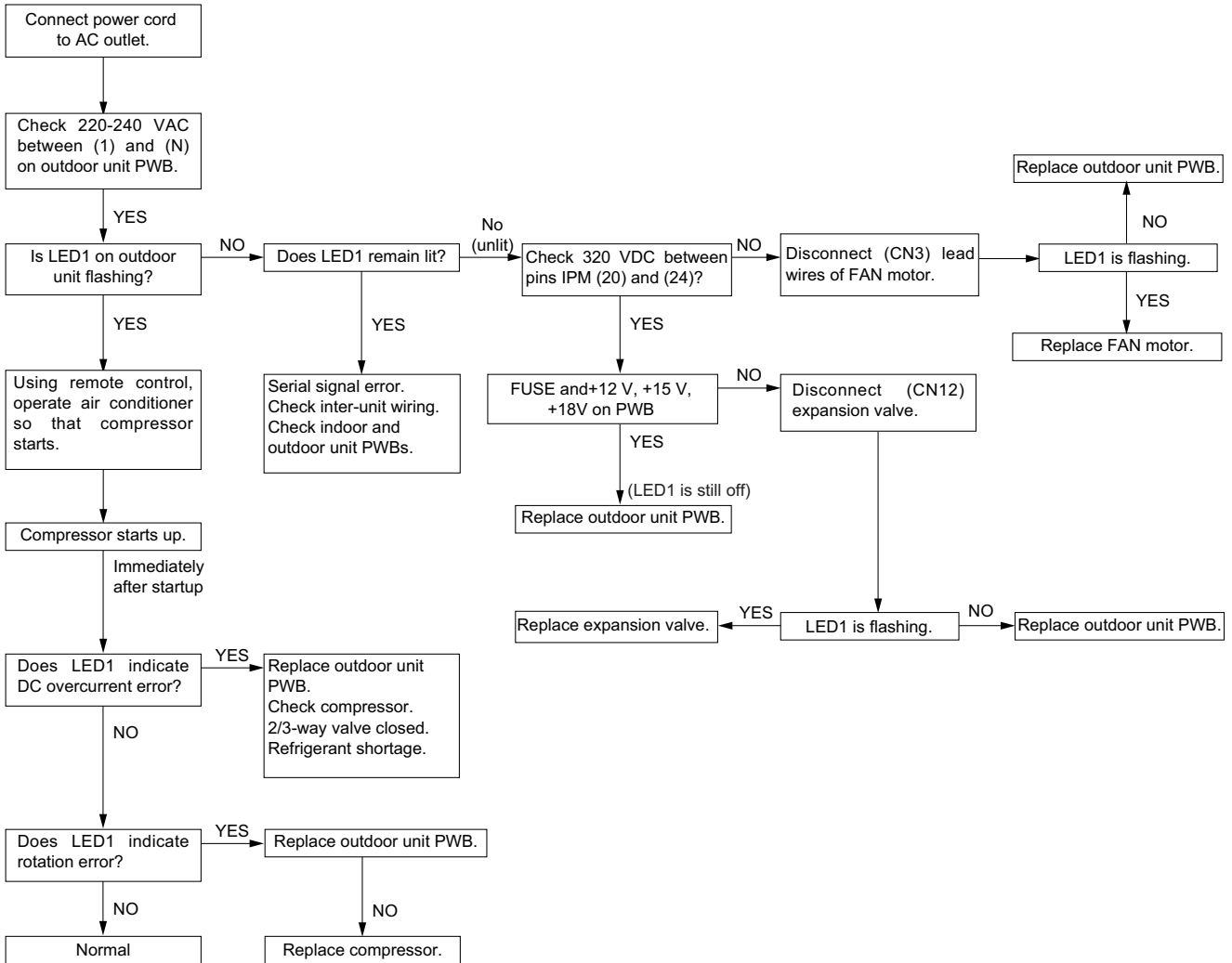

**CAUTION:** Please take care for electrical shock when you work to change defective parts or disconnect wires of defective application.

The outdoor unit has energy changed for a while even after unplugging the power supply cord.

After changing the part or unit, please retry check procedure from the beginning.

## 2. Procedure for determining defective expansion valve

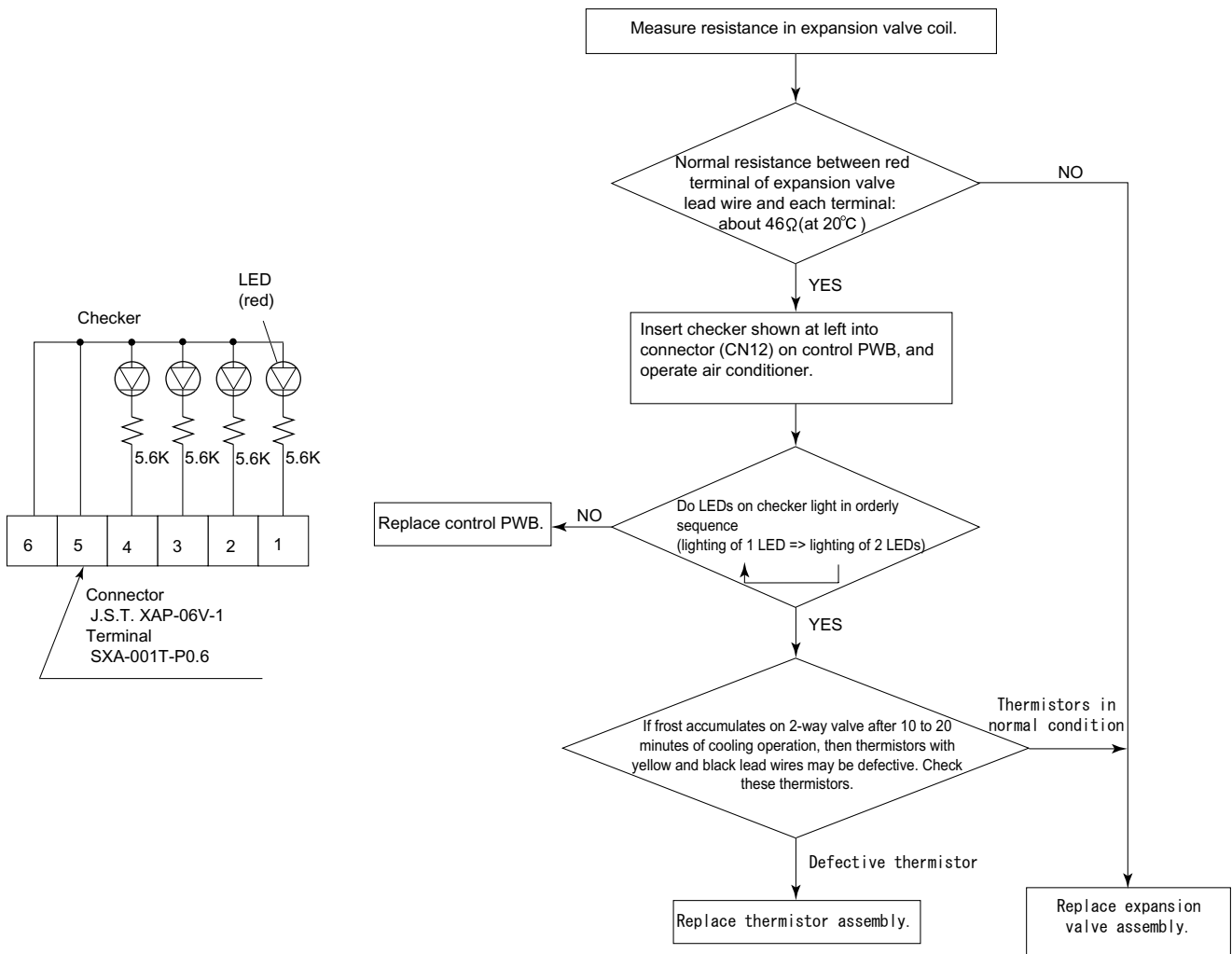

## 3. Diode bridge check method

Turn off the power and let the inverter electrolytic capacitor (C9, C10) discharge completely. Then use a tester and check continuity. When using a digital tester, the (+) and (-) tester lead wires in the table must be reversed.

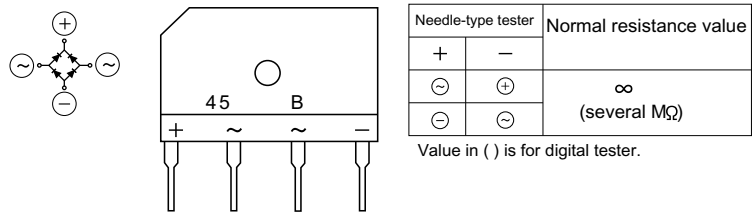

## 4. Inverter electrolytic capacitor (C9, C10) check method

Turn off the power, let the inverter electrolytic capacitor (C9, C10) discharge completely, and remove the capacitor from the control printed circuit board (PWB). First, check the case for cracks, deformation and other damages. Then, using a needle-type tester, check continuity.

**Determination of normal condition**

The tester needle should move on the scale and slowly returns to the original position. The tester needle should move in the same way when polarities are reversed. (When measurement is taken with the polarities reversed, the tester needle exceeds the scale range. Therefore, let the capacitor discharge before measurement.)

12KHR-N

5. IPM check method

Turn off the power, let the large capacity electrolytic capacitor (C10) discharge completely, and dismount the IPM. Then, using a tester, check leak current between C and E.

When using a digital tester, the (+) and (-) tester lead wires in the table must be reversed.

Needle-type tester		Normal resistance value
(-)	(+)	
P	N	$\infty$ (several M $\Omega$ )
	U	
	V	
	W	

Needle-type tester		Normal resistance value
(-)	(+)	
U	N	$\infty$ (several M $\Omega$ )
V		
W		

Values in ( ) are for digital tester.

5.1. IPM internal circuit diagram

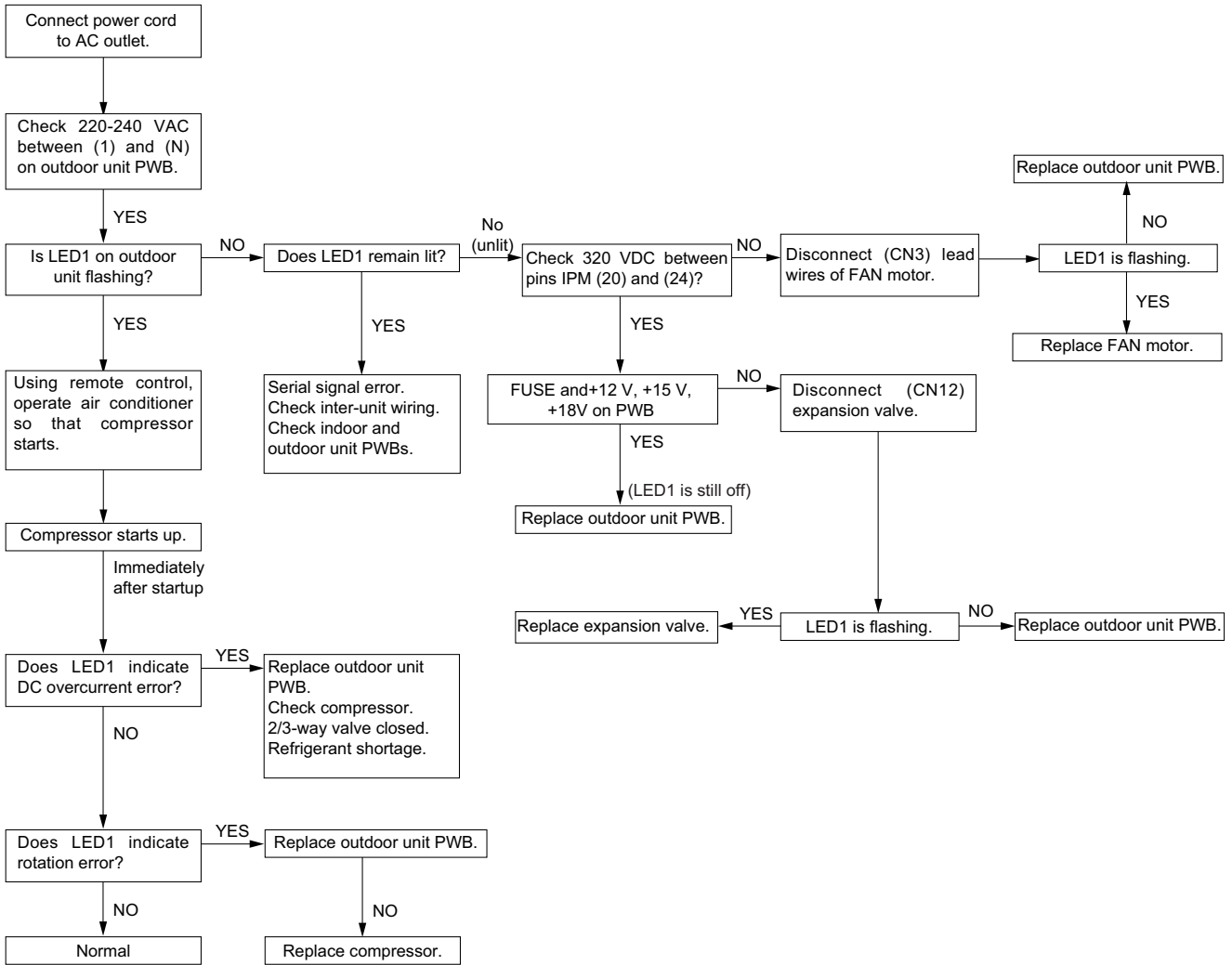

[7] OUTDOOR UNIT CHECK METHOD

After repairing the outdoor unit, conduct the following inspection procedures to make sure that it has been repaired completely. Then, operate the compressor for a final operation check.



## 1. Checking procedures

No	Item	Check method	Normal value/condition	Remedy
1	Preparation	Disconnect compressor cords (white, orange, red: 3 wires) from compressor terminals, and connect simulated load (lamp used as load). Operate air conditioner in cooling or heating test operation mode.		
2	Inverter DC power supply voltage check	Measure DC voltage between IPM pins (20) and (24).	320 VDC	Replace control PWB. Replace diode bridge. Correct soldered section of Fasten tabs (BT1,2,5,6,10,11, JPL1,2,5,6) on control PWB. (Repair solder cracks.)
3	IPM circuit check	Check that 3 lamps (load) light. Check position detection voltage (+15 V, 5 V) on control PWB.	Each voltage should be normal. All 3 lamps (load) should light with same intensity.	Replace control PWB.
4	Compressor check	Measure compressor coil resistance (for each phase of U, V and W). Use multi-meter or digital tester capable of displaying two digits right of the decimal point (0.01Ω).	Resistance value at 20°C --- 0.65Ω	Correct connections at compressor terminals. Replace compressor.
5	Expansion valve check	Measure expansion valve coil resistance.	Each phase 46±3Ω (at 20°C)	Replace expansion valve.
6	Final check	Turn off power, and connect compressor cords to compressor. Operate air conditioner. Measure DC voltage between IPM pins (20) and (24).	Compressor should operate normally. 320 VDC or higher.	Replace control PWB. Replace outdoor unit thermistor. Replace compressor (in case of compressor lock).

2. Troubleshooting of outdoor unit electric components

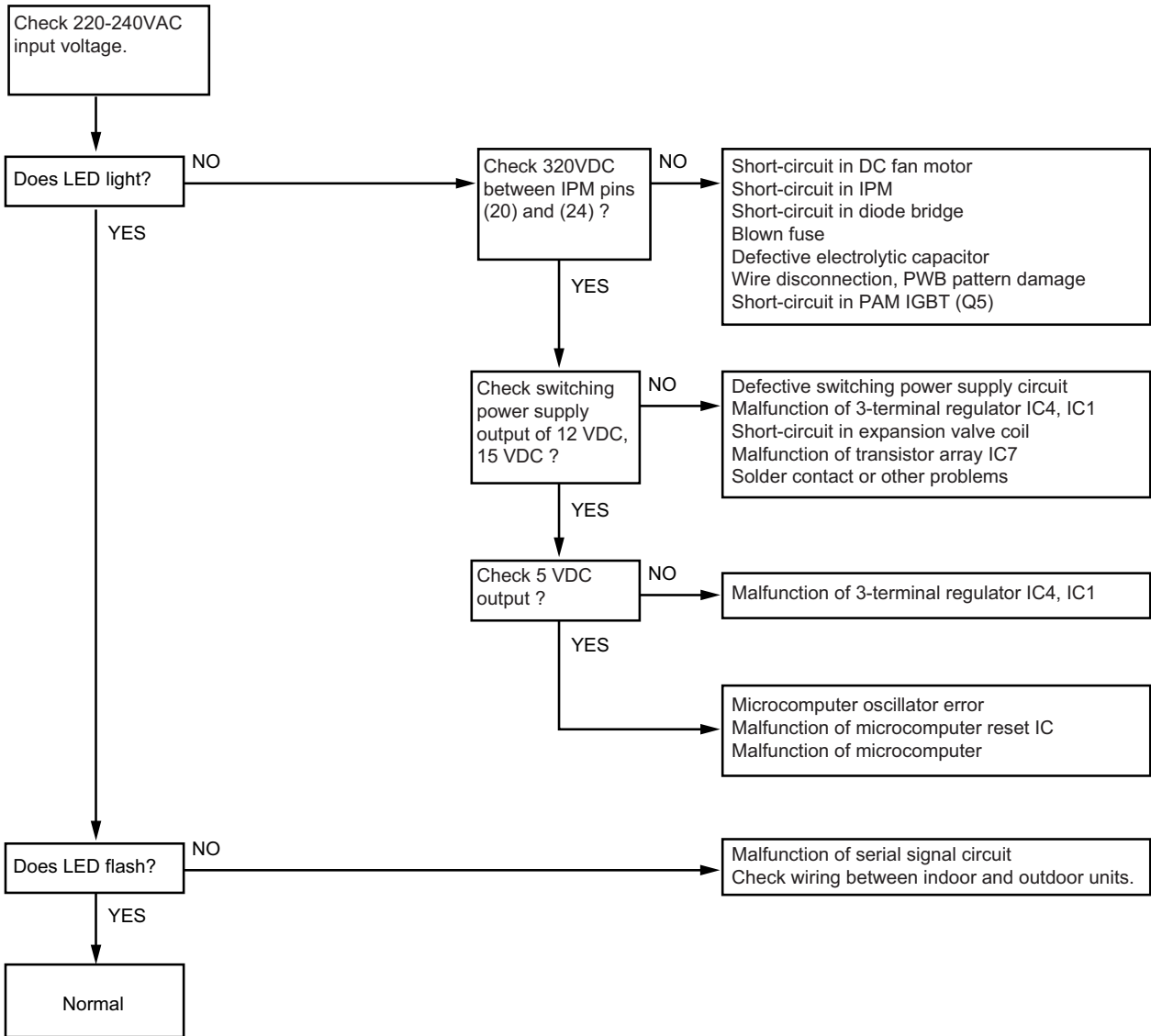

### 3. Caution in checking printed circuit boards (PWB)

#### 3.1. Non-insulated control circuit

The GND terminals of the low-voltage circuits (control circuits for microcomputer and thermistors and drive circuits for expansion valve and relays) on the control printed circuit board (PWB) are connected to the compressor drive power supply (320-VDC negative terminal). Therefore, exercise utmost caution to prevent electric shock.

If a measuring instrument used for the test is grounded, its chassis (ground) has the same electric potential as the 0-V probe. Since non-insulated circuits have the following voltage potential difference from the ground, connection of the grounding wire results in a short-circuit between the 0-V line and the ground, thus allowing an excessive current to flow to the tester to cause damage.

If the sheaths of the thermistor lead wires or expansion valve lead wires inside the outdoor unit become damaged due to pinching by the front panel or other metal parts or contacting a pipe, a high voltage can flow and destroy the circuits. To prevent these problems, carefully conduct assembly work.

