



SERVICE MANUAL

S570
DVD / VCD / CD
PLAYER

S570

DVD / VCD / CD
PLAYER

PRDUCT SAFETY SERVICING GUIDELINES FOR VIDEO PRODUCTS

CAUTION: DO NOT ATTEMPT TO MODIFY THIS PRODUCT IN ANYWAY. NEVER PERFORM CUSTOMIZED INSTALLATIONS WITHOUT MANUFACTURER'S APPROVAL. UNAUTHORIZED MODIFICATIONS WILL NOT ONLY VOID THE WARRANTY, BUT MAY LEAD TO YOUR BEING LIABLE FOR ANY RESULTING PROPERTY DAMAGE OR USER INJURY.

SERVICE WORK SHOULD BE PERFORMED ONLY AFTER YOU ARE THOROUGHLY FAMILIAR WITH ALL OF THE FOLOWING SAFETY CHECKS AND SERVICING GUIDELINS. TO DO OTHERWISE, INCREASES THE RISK OF POTENTIAL HAZARDS AND INJURY TO THE USER.

WHILE SERVICING, USE AN ISOLATION TRANSFORMER FOR PROTECTION FROM A.C. LINE SHOCK.

SAFETY CHECKS

AFTER THE ORIGINAL SERVICE PROBLEM HAS BEEN CORRECTED, A CHECK SHOULD BE MADE OF THE FOLLOWING.

SUBJECT: FIRE & SHOCK HAZARD

1. BE SURE THAT ALL COMPONENTS ARE POSITIONED IN SUCH A WAY AS TO AVOID POSSIBILITY OF ADJACENT COMPONET SHORTS. THIS IS ESPECIALLY IMPORTANT ON THOSE MODULES WHICH ARE TRANSPORTED TO AND FROM THE REPAIR SHOP.

2. NEVER RELEASE A REPAIR UNLESS ALL PROTECTIVE DEVICES SUCH AS INSULATORS, BARRIERS, COVERS, SHIELDS, STRAIN RELIEFS, POWER SUPPLY CORDS, AND OTHER HARDWARE HAVE BEEN REINSTALLED PER ORIGINAL DESIGN. BE SURE THAT THE SAFETY PURPOSE OF THE POLARIZED LINE PLUG HAS NOT BEEN DEFEATED.

3. SOLDERING MUST BE INSPECTED TO DISCOVER POSSIBLE COLD SOLDER JOINTS, SOLDER SPLASHES OR SHARP SOLDER POINTS. BE CERTAIN TO REMOVE ALL LOOSE FOREIGN PARTICLES.

4. CHECK FOR PHYSICAL EVIDENCE OF DAMAGE OR DETERIORATION TO PARTS AND COMPONENTS. FOR FRAYED LEADS, DAMAGED INSULATION (INCLUDING A.C. CORD) AND REPLACE IF NECESSARY FOLLOW ORIGINAL LAYOUT, LEAD LENGTH AND DRESS.

5. NO LEAD OR COMPONENT SHOULD TOUCH A RECVING TUBE OR A RESISTOR RATED AT 1 WATT OR MORE. LEAD TENSION AROUND PROTRUNING METAL SURFACES MUST BE AVOIDED.

6. ALL CRITICAL COMPONENTS SUCH AS FUSES, FLAMEPRO OF RESISTORS, CAPAICTORS, ETC. MUST BE REPLACED WITH EXACT FACTORY TYPES. DO NOT USE REPLACEMENT COMPONETS OTHER THAN THOSE SPECIFIED OR MAKE UNRECOMMENDED CIRCUIT MODIFICATIONS.

7. AFTER RE-ASSEMBLY OF THE SET ALWAYS PERFORM AN A.C. LEAKAGE TEST ON ALL EXPOSED METALLIC PARTS OF THE CABINET, (THE CHANNEL SELECTOR KNOB, ANTENNA TERMINALS, HANDLE ADN SCREWS) TO BE SURE THE SET IS SAFET TO OPERATE WITHOUT DANGER OF ELECTRICAL SHOCK. DO NOT USE A LINE ISOLATION TRANSFORMER DURING THIS TEST USE AN A.C. VOLTMETER, HAVING 5000 OHMS PER VOLT OR MORE SENSITIVITY, IN THE FOLLOWING MANNER; CONNECT A 1500OHM 10 WATT RESISTOR, PARALLELED BY A .15 MFD, 150.V A.C. TYPE CAPACITOR BETWEEN A KNOWN GOOD EARTH GROUND (WATER PIPE, CONDUIT, ETC.) AND THE EXPOSED METALLIC PARTS, ONE AT A TIME.

MEASURE THE A.C. VOLTAGE ACROSS THE COMBINATION OF 1500 OHM RESISTOR AND .15 MFD CAPACITOR.

REVERSE THE A.C. PLUG AND REPEAT A. C. VOLTAGE MEASUREMENTS FOR EACH EXPOSED METALLIC PART.

VOLTAGE MEASURE MUST NOT EXCEED 75 VOLTS R.M.S. THIS

CORRESPONDS TO 0.5 MILLIAMPS A.C. ANY VALUE EXCEEDING THIS LIMIT CONSTITUTED A POTENTIAL SHOCK HAZARD AND MUST BE CORRECTED IMMEDIATELY.

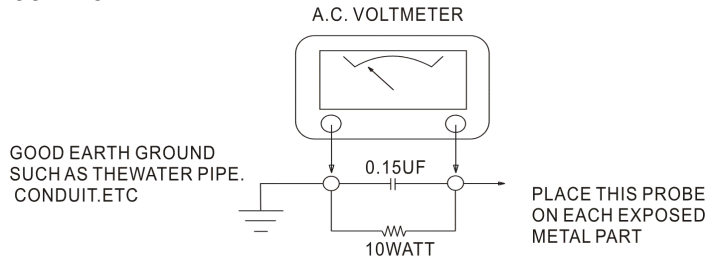

SUBJECT: GRAPHIC SYMBOLS



THE LIGHTNING BOLT WITH ARROWHEAD SYMBOL, WITHIN AN EQUILATERAL TRIANGLE, IS INTENDED TO ALERT THE USER TO THE PRESENCE OF UNINSULATED "DANGEROUS VOLTAGE" WITHIN THE PRODUCT'S ENCLOSURE THAT MAY BE OF SUFFICIENT MAGNITUDE TO CONSTITUTE A RISK OF ELECTRIC SHOCK.



THE EXCLAMATION POINT WITHIN AN EQUILATERAL TRIANGLE IS INTENDED TO ALERT THE USER TO THE PRESENCE OF IMPORTANT OPERATING AND MAINTENANCE (SERVICING) INSTRUCTIONS IN THE LITERATURE ACCOMPANYING THE APPLIANCE.

SUBJECT: TIPS ON PROPER INSTALLATION

1. NEVER INSTALL ANY PRODUCT IN A CLOSED-IN RECESS, CUBBYHOLE OR CLOSELY FITTING SHELF SPACE. OVER OR CLOSE TO HEAT DUCT, OR IN THE PATH OF HEATED AIR FLOW.
2. AVOID CONDITIONS OF HIGH HUMIDITY SUCH AS: OUTDOOR PATIO INSTALLATIONS WHERE DEW IS A FACTOR, NEAR STEAM RADIATORS WHERE STEAM LEAKAGE IS FACTOR, ETC.
3. AVOID PALCEMNET WHERE DRAPERIES MAY OBSTRUCT REAR VENTING. THE CUSTOMER SHOULD ALSO AVOID THE USE OF DECORATIVE SCARVES OR OTHER COVERINGS WHICH MIGHT OBSTRUCT VENTILATION.
4. WALL AND SHELF MOUNTED INSTALLATIONS USING A COMMERCIAL MOUNTING KIT. MUST FOLLOW THE FACTORY APPROVED MOUNTING INSTRUCTIONS A PRODUCT MOUNTED TO A SHELF OR PLATFORM MUST RETAIN ITS ORIGINAL FEET (OR THE EQUIVALENT THICKNESS IN SPACERS) TO PROVIDE ADEQUATE AIR FLOW ACROSS THE BOTTOM, BOLTS OR SCREWS USED FOR FASTENERS MUST NOT TOUCH ANY PARTS OR WIRING. PERFORM LEAKAGE TEST ON CUSTOMIZED INSTALLATIONS.
5. CAUTION CUSTOMERS AGAINST THE MOUNTING OF A PRODUCT ON SLOPING SHELF OR TILTED POSITION, UNLESS THE PRODUCT IS PROPERLY SECURED.
6. A PRODUCT ON A ROLL-ABOUT CART SHOULD BE STABLE ON ITS MOUNTING TO THE CART. CAUTION THE CUSTOMER ON THE HAZARDS OF TRYING TO ROLL A CART WITH SMALL CASTERS ACROSS THRESHOLDS OR DEEP POLE CARPETS.
7. CAUTION CUSTOMERS AGAINST THE USE OF A CART OR STAAND WHICH HAS NOT BEEN LISTED BY UNDERWRITERS LABORATORIES, INC. FOR USE WITH THEIR SPECIFIC MODEL OF THELVISION RECEIVER OR GENERICALLY APPROVED FOR USE WITH T.V.'S OF THE SAME OR LARGER SCREEN SIZE.
8. CAUTION CUSTOMERS AGAINST THE USE OF EXTENSION CORDS, EXPLAIN THAT A FOREST OF EXTENSIONS SPROUTING FROM A SINGAL OUTLET CAN LEAD TO DISASTROUS CONSEQUENCES TO HOME AND FAMILY.

SERVICING PRECAUTIONS

CAUTION:

Before servicing the DVD player covered by this service data and its supplements and addends, read and follow the SAFETY PRECAUTIONS. NOTE: if unforeseen circumstances create conflict between the following servicing precautions and any of the safety precautions in this publications, always follow the safety precautions.

Remembers Safety First:

General Servicing Precautions

1. Always unplug the DVD player AC power cord from the AC power source before:

- (1) Removing or reinstalling any component, circuit board, module, or any other assembly.
- (2) Disconnection or reconnecting any internal electrical plug or other electrical connection.
- (3) Connection a test substitute in parallel with an electrolytic capacitor.

Caution: A wrong part substitution or incorrect polarity installation of electrolytic capacitors may result in an explosion hazard.

2. Do not spray chemicals on or near this DVD player or any of its assemblies.

3. Unless specified otherwise in this service data, clean electrical contacts by applying an appropriate contact cleaning solution to the contacts with a pipe cleaner, cottontipped swab, or comparable soft applicator.

Unless specified otherwise in this service data, lubrication of contacts is not required.

4. Do not defeat any plug/socket B+ voltage interlocks with which instruments covered by this service manual might be equipped.

5. Do not apply AC power to this DVD player and/or any of its electrical assemblies unless all solid-state device heat sinks are correctly installed.

6. Always connect test instrument ground lead to the appropriate ground before connection the test instrument positive lead. Always remove the test instrument ground lead last.

Insulation Checking Procedure

Disconnect the attachment plug from the AC outlet and turn the power on. Connect an insulation resistance meter (500V) to the blade of the attachment plug. The insulation resistance between each blade of the attachment plug and accessible conductive parts (Note 1) should be more than 1M-ohm.

Note 1: Accessible Conductive Parts including Metal panels, Input terminals, Earphone jacks, etc.

Electrostatically Sensitive (ES) Devices

Some semiconductor (solid state) devices can be damaged easily by static electricity. Such components commonly are called Electrostatically Sensitive (ES) Devices. Examples of typical Es devices are integrated circuits and some field effect transistors and semiconductor chip components.

The following techniques should be used to help reduce the incidence of component damage caused by static electricity.

1. Immediately before handling any semiconductor component or semiconductor equipped assembly, drain off any electrostatic charge on your body by touching a known earth ground. Alternatively, obtain and wear a commercially available discharging wrist strap device, which should be removed for potential shock reasons prior to applying power to the unit under test.

2. After removing an electrical assembly equipped with ES devices, place the assembly on a conductive surface such as an aluminum foil, to prevent electrostatic charge buildup or exposure of the assembly.

3. Use only a grounded-tip soldering iron to solder or unsolder ES devices.

4. Use only an antistatic solder removal device. Some solder removal devices not classified an "antistatic" can generate electric charges sufficient to damage ES devices.

5. Do not use freonpropelled chemicals. These can generate electrical charge sufficient to damage ES devices.

6. Do not remove a replacement ES device from its protective package until immediately before you are ready to install it. (Most replacement ES devices are packaged with leads electrically shorted together by conductive foam, aluminum foil, or comparable conductive material).

7. Immediately before removing the protective material from the leads of a replacement ES device, touch the protective material to the chassis or circuit assembly into which the device will be installed.

Caution: Be sure no power is applied to the chassis or circuit, and observe all other safety precautions.

8. Minimize bodily motions when handling unpackaged replacement ES devices. (Normally harmless motion such as the brushing together of your clothes fabric or the lifting of your foot from a carpeted floor can generate static electricity sufficient to damage an ES device.)

SPECIFICATIONS

DVD VIDEO PLAYER

POWER SUPPLY.....	AC 230V,50Hz (EUR)/120V,60Hz(US/CANADA)
Power consumption.....	30W
External dimensions.....	435×80×280mm
Weight (net).....	4.6kg
Signal system.....	PAL (EUR)/NTSC (USA/CANADA)
Laser.....	Semiconductor laser, wavelength 650nm
Frequency range(digital audio).....	2Hz to 22kHz
Signal-to-noise.....	More than 102dB(A-WEIGHTED)
Audio dynamic	More than 92dB
Harmonic distortion	0.008%
Operating conditions.....	Temperature: 41° to 95°, operation status: Horizontal

OUTPUTS

Video output	1.0V (p-p), 75Ω, negative sync., RCA jack×1
S-video output.....	(Y) 1.0V (P-P), 75Ω,negative sync., Mini DIN 4pin×1 (C) 0.286V (P-P), 75Ω
Component Video output	(Y)1.0V (P-P), 75Ω,negative sync., (Cb、 Cr) 0.5V (P-P), 75Ω
Scart Video output.....	(CVBS)1.0V(P-P) ,75Ω,negative sync., (R、 G、 B)0.7V(P-P),75Ω
Audio output(digital audio)	0.5V(p-p) 75Ω, RCA jack×1
Audio output(analog audio)	2.0Vrms(1kHz, 0dB), RCA jack×1

Identification of Controls

FRONT PANEL

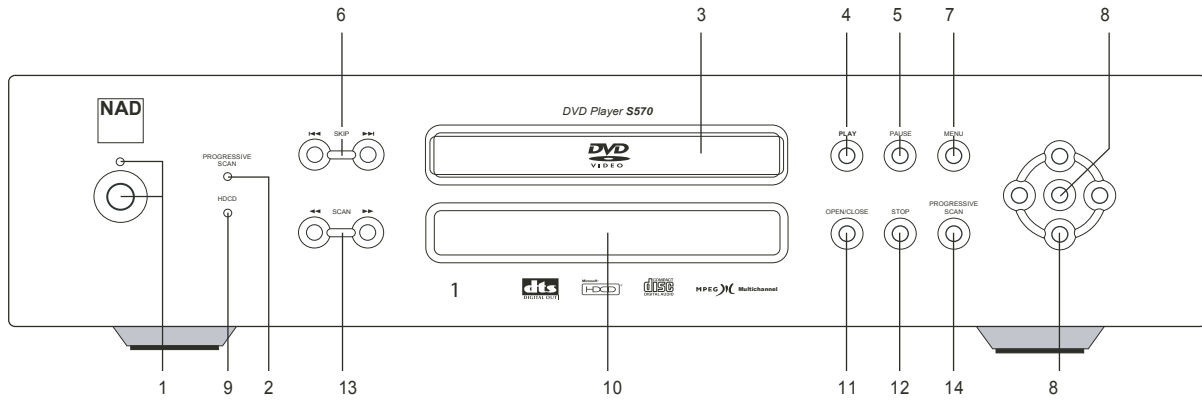

- | | |
|---|-----------------------------|
| 1 Power button and on/standby/off indicator | 8 SELECT/navigation buttons |
| 2 PROGRESSIVE SCAN indicator | 9 HDCD indicator |
| 3 DVD tray | 10 Display window |
| 4 PLAY button | 11 OPEN/CLOSE button |
| 5 PAUSE buttons | 12 STOP button |
| 6 SKIP buttons | 13 SCAN buttons |
| 7 MENU button | 14 PROGRESSIVE SCAN button |

REAR PANEL (NORTH AMERICAN VERSION)

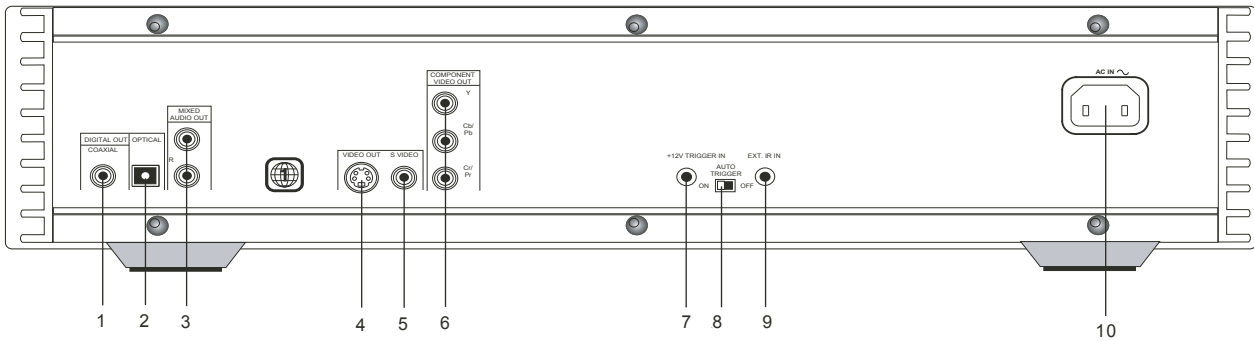

- | | |
|---|------------------------------|
| 1 DIGITAL OUT COAX Jack | 6 COMPONENT VIDEO OUT Jacks |
| 2 DIGITAL OUT OPTICAL (With Dust Protection Cap) Jack | 7 +12V TRIGGER IN Jack |
| 3 MIXED AUDIO OUT (L & R) Jacks | 8 AUTO TRIGGER ON-OFF Switch |
| 4 S-VIDEO OUT Jack | 9 EXT. IR IN Jack |
| 5 VIDEO OUT Jack | 10 Power cord |

REAR PANEL (EUROPEAN VERSION)

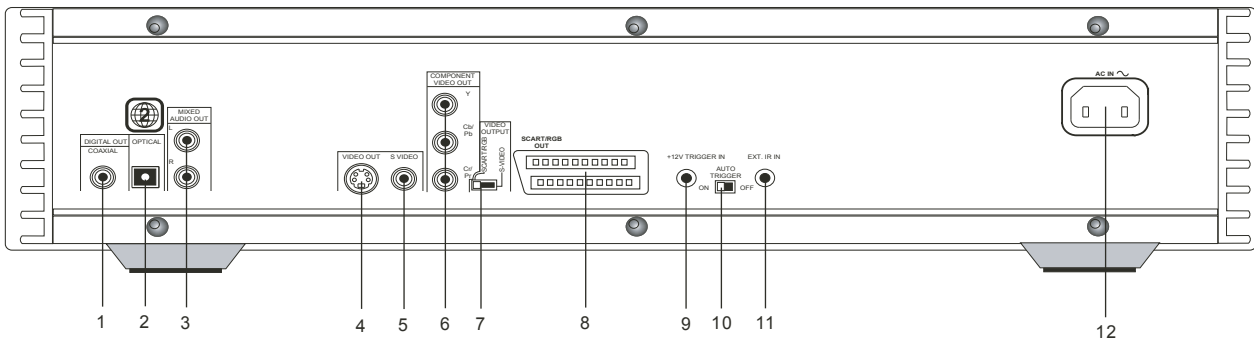

- | | |
|---|---|
| 1 DIGITAL OUT COAX Jack | 7 VIDEO OUTPUT S-VIDEO-SCART/RGB Switch |
| 2 DIGITAL OUT OPTICAL (With Dust Protection Cap) Jack | 8 SCART/RGB OUT Jack |
| 3 MIXED AUDIO OUT (L & R) Jacks | 9 12V TRIGGER IN jack |
| 4 S-VIDEO OUT Jack | 10 AUTO TRIGGER ON-OFF Switch |
| 5 Composite VIDEO OUT Jack | 11 EXT. IR IN Jack |
| 6 COMPONENT VIDEO OUT Jacks | 12 Power cord socket |

DISPLAY WINDOW

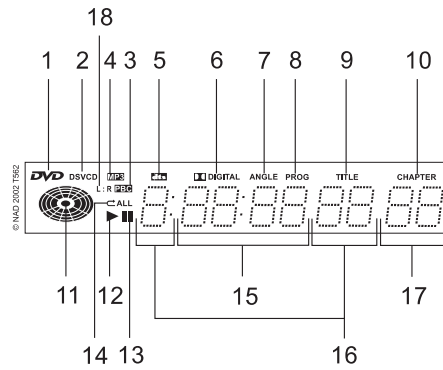

- | | |
|---------------------------|------------------------------------|
| 1 DVD indicator | 10 CHAPTER Indicator |
| 2 VCD indicator | 11 Operating status indicator |
| 3 PBC indicator for VCD | 12 Playback indicator |
| 4 MP3 indicator | 13 Pause indicator |
| 5 DTS indicator | 14 Repeat playback mode indicators |
| 6 DOLBY DIGITAL indicator | 15 Total playing time display |
| 7 ANGLE indicator | 16 Title/track number display |
| 8 PROGram indicator | 17 Chapter number display |
| 9 TITLE Indicator | 18 L R indicator |

REMOTE CONTROL

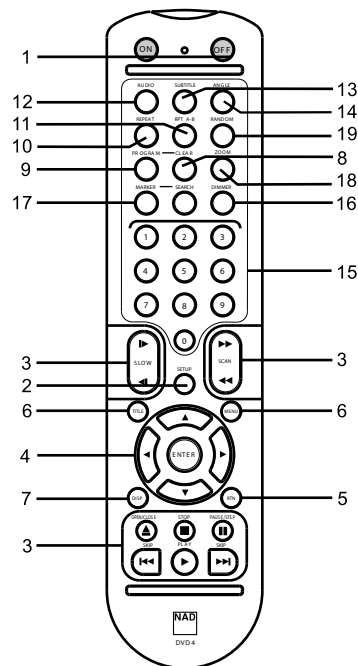

- | | |
|--|----------------------|
| 1 POWER ON, POWER OFF | 11 REPEAT A-B |
| 2 SETUP | 12 AUDIO |
| 3 Transport control keys OPEN/CLOSE, STOP, PAUSE, STEP, PLAY, SKIP, SCAN, SLOW | 13 SUBTITLE |
| 4 ENTER and navigation buttons | 14 ANGLE |
| 5 RETURN | 15 Numerical buttons |
| 6 TITLE, MENU | 16 DIMMER |
| 7 DISPLAY | 17 MARKER, SEARCH H |
| 8 CLEAR | 18 ZOOM |
| 9 PROGRAM | 19 RANDOM |
| 10 REPEAT | |

EXPLODED VIEW

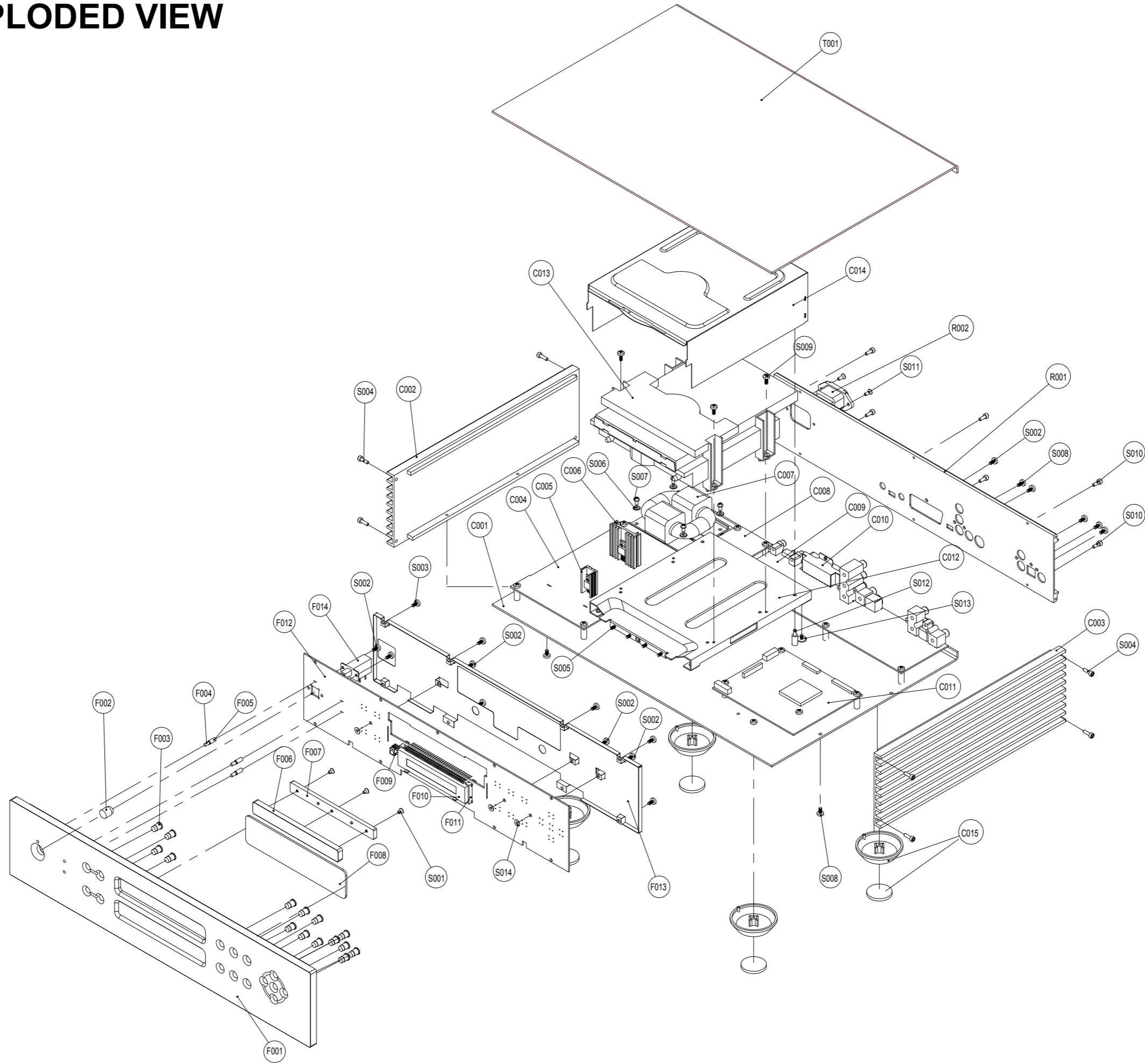

EXPLODED VIEW PARTS LIST

REF.NO.	PART NO.	DESCRIPTION	Qty.	REF.NO.	PART NO.	DESCRIPTION	Qty.
C001	67-017014-0	Base Cover	1	F009	66-017004-0	IR Bracket	1
C002	67-017005-0	Left Side Panel	1	F010	23-56119-00	VFD	1
C003	67-017006-0	Right Side Panel	1	F011	75-017002-0	Display Bracket	1
C004	01-57004-01	SMPS PCB with components	1	F012	01-57003-01	Control PCB with Components	1
C005	70-009002-0	Heatsink 1	1	F013	66-017002-0	FPP Shielding Plate	1
C006	70-017001-1	Heatsink 2	1	F014	11-01201-01	Power Switch	1
C007	18-57015-00	R Core Transformer(C Version)	1	R001	67-017002-0	Rear Panel (C Version)	1
	18-57015-01	R Core Transformer(AH Version)	1		67-017008-0	Rear Panel (AH Version)	1
C008	16-57004-02	Analog PS PCB with components	1	R002	17-07002-00	AC Inlet, 3516-T1C02, for C and AH Verion	1
C009	01-57002-20	Audio/Video PCB with Components (C)	1				1
	01-57001-10	Audio/Video PCB with Components (AH)	1				
C010	66-009005-0	Scart Bracket(C Version)	1	T001	67-017003-0	Top Cover	1
C011	01-56202-20	Decoder PCB with components (C)	1				
	01-56202-10	Decoder PCB with components (AH)	1	S001	61-063505-1	Machine Screw (MF3X5)	3
C012	66-017001-1	DVD Loading Support	1	S002	61-023106-2	Self Taping Screw (STB3X6)	26
C013	36-00021-00	Mechanism	1	S003	61-023208-1	Self Taping Screw (BTB3X8)	8
C014	66-017005-0	Loader Cover	1	S004	61-223510-0	Hex Head Screw (M3X10)	8
C015	83-017001-0	Foot	4	S005	61-223506-0	Hex Head Screw (M3X6)	4
				S006	63-010316-0	Pan Washer (Φ3)	4
F001	67-017001-1	FASCIA	1	S007	61-023505-1	Machine Screw (MB3X5)	4
F002	74-017001-0	Powerbutton	1	S008	61-023206-1	Self Taping Screw (BTB3X6)	10
F003	74-017002-0	Inputbutton	15	S009	61-023108-1	Self Taping Screw (STB3X8)	6
F004	33-50360-00	LED, Blue	3	S010	61-223508-0	Hex Head Screw (M3X8)	6
F005	75-017004-0	LED Spacer	3	S011	61-063508-1	Machine Screw (MF3X8)	2
F006	67-017007-0	DVD Tray Door	1	S012	61-013017-0	Bolt	2
F007	75-017003-0	Lid Clamp	1	S013	63-131015-0	Rubber Washer	2
F008	76-017001-0	VFD window	1	S014	63-010303-0	Washer (Φ3 X0.3mm)	3

PACKING DIAGRAM

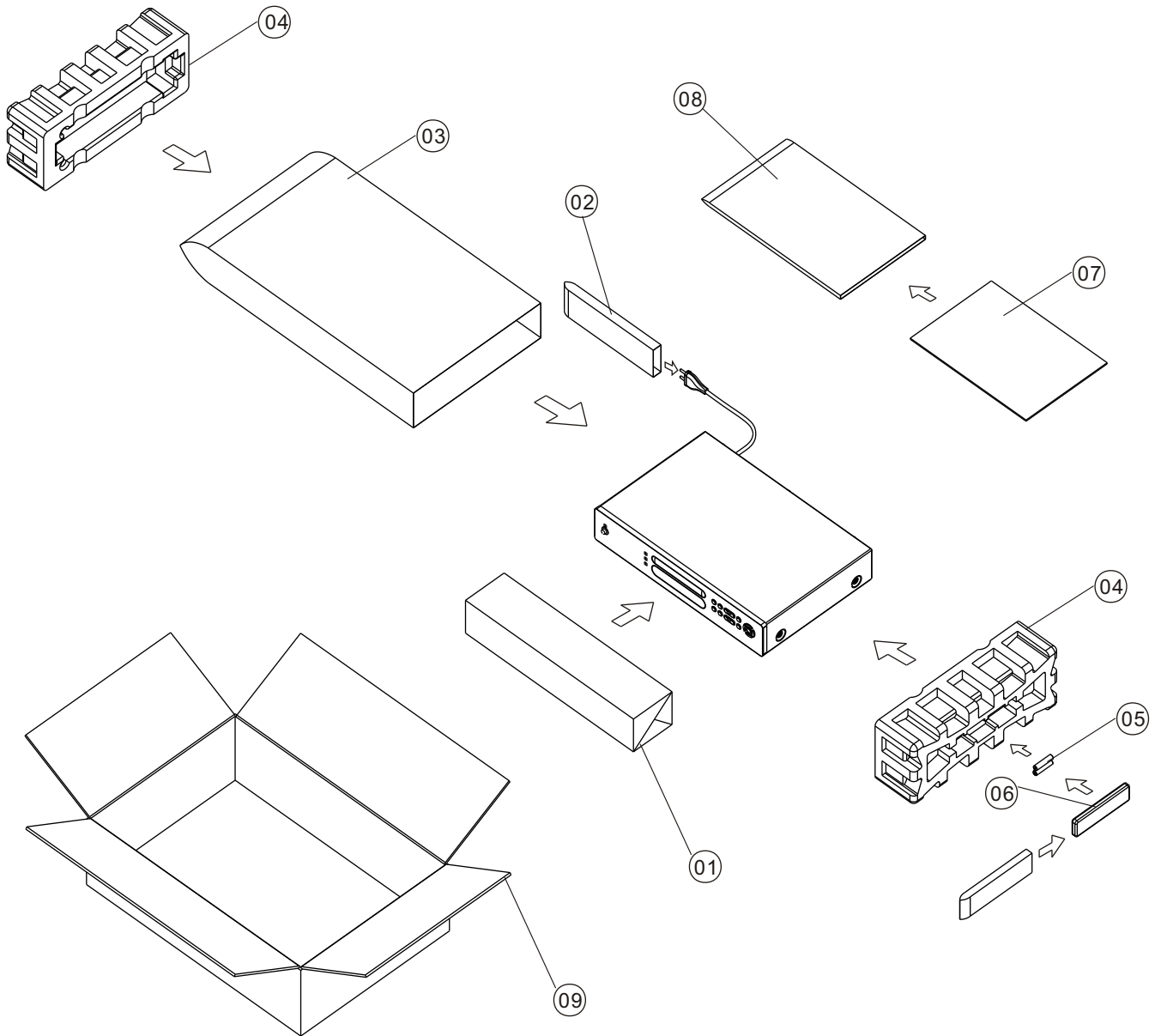

Ref. No.	Part No.	Description	Q'TY
01.	90-002001-0	EPE Fascia Cover	1
02.	90-001003-0	AC Cord Polybag	1
03.	90-001001-0	Polybag	1
04.	89-002001-0	Polyfoam End Cap	2
05.	30-23200-00	Batteries	2
06.	30-15600-00	Remote Control	1
07.	30-45600-01	IM 1(Eng. Starts)	1
	30-45600-02	IM 2(Spa. Starts)	1
08.	90-009001-1	Manual Polybag	1
09.	88-009001-0	Carton Box C Version	1
	88-009002-0	Carton Box AH Version	1

Proprietary information for servicing purposes only.
 The information herein may not be used commercially without the prior written agreement
 of NAD International, Toronto, Canada.

IC BLOCK DIAGRAMS & SIGNAL DESCRIPTION

1. U5 (V8601VWA DVD DSP)

SIGNAL DESCRIPTION

Signal	I/O	Pins	Description
Front End			
DSYNC	I	213	DVD parallel mode Sector Sync
DREQ	O	214	DVD parallel mode Data Request
DCLK	I	215	Data sampling clock
DSTB	I	216	Parallel mode Data Valid, serial mode Left/Right Clock
DVD[7:0]	I	*	DVD drive parallel data port, pins: 217, 219-223, 225, 226
External I/O			
PCS0	O	193	Peripheral chip select 0, generally used for enabling the program store ROM/FLASH
XIO[14:1]	B		Programmable general purpose I/O also used as peripheral chip select, interrupt, PWM output and other system signals, pins: 195, 197-200, 202-203, 205-209, 211
SDRAM			
MD[31:0]	B	*	SDRAM data bus, pins: 227, 229, 231, 232, 234, 235, 236, 238, 239, 240, 2, 3, 5, 7, 8, 9, 43, 45, 46, 48, 50, 51, 52, 54, 55, 56, 58, 59, 60, 61, 63, 64
MA[11:0]	O	*	SDRAM address bus, pins: 12, 13, 15, 16, 18, 20, 21, 25, 26, 28, 29, 30
MA[13:12]	O	32-33	SDRAM address bus, reserved for pin compatibility with 64Mbit SDRAM
MCLK	O	22	SDRAM clock
CKE	O	24	SDRAM Clock Enable
CS0-	O	35	SDRAM primary bank chip select
CS1-	O	66	SDRAM extension bank chip select
RAS-	O	37	SDRAM command bit
CAS-	O	38	SDRAM command bit
WE-	O	39	SDRAM command bit
DQM[3:0]-	O	11, 41, 42, 65	SDRAM data byte enables
Host Interface			
AD[31:0]	B	*	P multiplexed address/data bus, pins: 136-139, 141-144, 146, 148-153, 155, 157, 158, 163-168, 172-176, 78-180
LA[3:0]	B	184-187	Latched Address [3:0]
ALE	B	183	Address Latch Enable
RD-	B	189	Read
ACK-	B	161	Programmable WAIT-/ACK-/RDY- control
SCLK	O	160	External bus clock used for programmable host bus peripherals
PWE[3:0]-	B	*	Byte write enable for FLASH, EEPROM, SRAM or peripherals, pins: 145, 156, 170, 182
Slave Mode			
LHLD	I	191	Bus Hold Request from external master in slave mode
LHLDA	O	190	Bus Hold Acknowledge in slave mode

Signal	Type	Pins	Description
Comm Ports			
UART1			
RXD1	I	83	UART1 serial data input from external serial device, used for IR receive / can be used as GPIO
SSP1			
SSPCLK1/CTS1-	B	87	SSP1 clock or UART1 Clear to Send signal / can be used as GPIO
SSP0UT1/DTR1-	B	86	SSP1 data out or UART1 Data Terminal Ready signal / can be used as GPIO
SSPIN1/BAUD1	B	84	SSP1 data in or 16X clock for USART function in UART1 / can be used as GPIO
UART0			
RXD0	I	94	UART0 serial data input from external serial device / can be used as GPIO
TXD0	B	93	UART0 serial data output to an external serial device / can be used as GPIO
RTS0	B	96	UART0 request to send / can be used as GPIO
CTS0	B	95	UART0 Clear to Send signal / can be used as GPIO
SSP0			
SSP0UT0/DTR0	B	92	SSP0 data out or UART0 Data Terminal Ready signal / can be used as GPIO
SSPIN0/BAUD0	B	90	SSP0 data in or 16X clock for USART function in UART0 / can be used as GPIO
SSPCLK0/RTS1	B	88	SSP0 clock or Request To Send function in UART1 / can be used as GPIO
System Interface			
RSTP-	I	81	RESET_Power- from system, used to reset frequency synthesizer & rest of chip
SRST-	O	80	Active low RESET signal for peripheral reset
Video Interface			
DAC0	O	118	Video DAC0 output (Composite video; Chrominance output for S-Video)
DAC1	O	114	Video DAC1 output (Luminance for S-Video and component; G output for SCART)
DAC2	O	112	Video DAC2 output (Chrominance output for NTSC/PAL S-Video; Cb output for component; Blue output for SCART)
DAC3	O	110	Video DAC3 output (A second composite video; Cr output for component; Red output for SCART)
IOM	O	111	Cascaded DAC differential output used to dump current into external resistor for power
VREF	I	116	Input voltage reference (1.2V typ) for output DACs
RSET	O	119	Current setting resistor of output DACs
COMP	O	120	Compensation capacitor connection
Vdd _{DAC}	P	108	DAC Digital Power/1.8V
Vss _{DAC}	P	109	DAC Digital Ground
Vaa3	P	113	DAC Analog Power/3.3V
NC (Vaa)	-	117	Unused (was Vaa = 2.5V on NDV8501 device, can be connected to 1.8V without problem)
Vssa	P	115	DAC Analog Ground

Signal	Type	Pins	Description
Video Port			
VIO[7:0]	B	126-131 133-134	Bidirectional digital video port data bus / can be used as GPIO
HSYNC	B	124	Bidirectional HSYNC signal for devices that do not use EAV/SAV codes / can be used as GPIO
VSYNC	B	123	Bidirectional VSYNC signal for devices that do not use EAV/SAV codes / can be used as GPIO
VIOCLK	B	122	VCLK input/output for Video I/O Port function
Audio Interface			
AOUT0	O	74	Serial audio output data to audio DAC for Left & Right channels / can be used as GPIO
AOUT1	O	73	Serial audio output data to audio DAC for Center & LFE channels / can be used as GPIO
AOUT2	O	72	Serial audio output data to audio DAC for Surround Left & Right channels / can be used as GPIO
AOUT3	O	71	Serial audio output data to audio DAC for Left & Right channels for down-mixed stereo / can be used as GPIO
SPDIF	O	68	S/PDIF digital audio output
ACLK	O	78	Audio interface serial data clock, common clock for DACs & ADC
PCMCLK	O	76	Audio DAC PCM sampling clock frequency, common clock for DACs & ADC / can be used as GPIO
LRCLK	O	79	Left/Right Channel clock, common clock for DACs & ADC
AIN	I	70	Digital audio input for digital micro / can be used as GPIO
Clock Signals			
CXI	I	98	Crystal Input pin for on-chip oscillator or system input clock
CXO	O	99	Crystal Output pin for on-chip oscillator
OSCVdd	P	101	Oscillator Power (1.8V)
OSCVss	P	100	Oscillator Ground
MVCKVdd	P	102	Main & Video Clock PLL Power (3.3V)
MVCKVss	P	104	Main & Video Clock PLL Ground
ACLKVdd	P	107	Audio clock PLL Power (3.3V)
ACLKVss	P	105	Audio clock PLL Ground
Test			
SCEN	I	103	Scan Chain test enable
SCMD	I	106	Scan Chain test mode
PWR & GND			
V _{DD}	P	*	Core Power =1.8V, pins: 4, 34, 77, 89, 135, 159, 192, 212
V _{SS}	P	*	Core & Ring Ground, pins: 17, 47, 69, 85, 121, 171, 201, 230
V _{DDIO}	P	*	I/O Pad power = 3.3V, pins: 1, 10, 19, 27, 36, 44, 53, 62, 75, 91, 125, 140, 154, 169, 181, 196, 210, 224, 233
V _{SSIO}	P	*	I/O Pad ground, pins: 6, 14, 23, 31, 40, 49, 57, 67, 82, 97, 132, 147, 162, 177, 188, 204, 218, 228, 237

BLOCK DIAGRAM

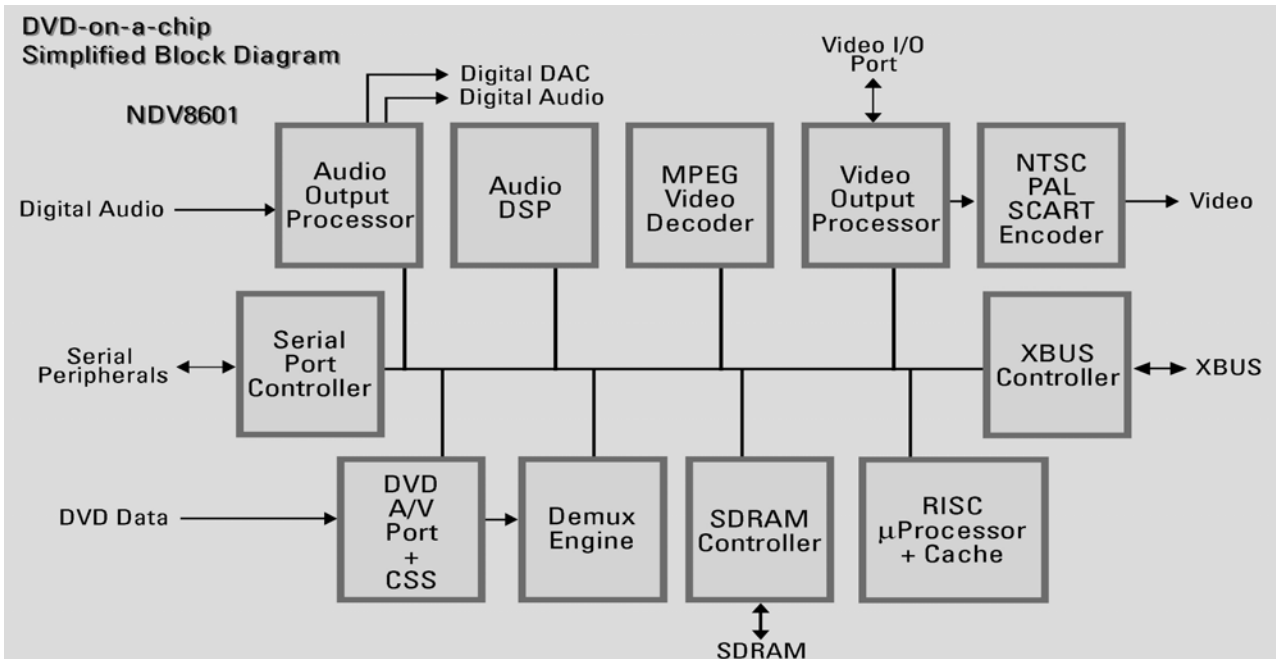

PIN CONNECTIONS

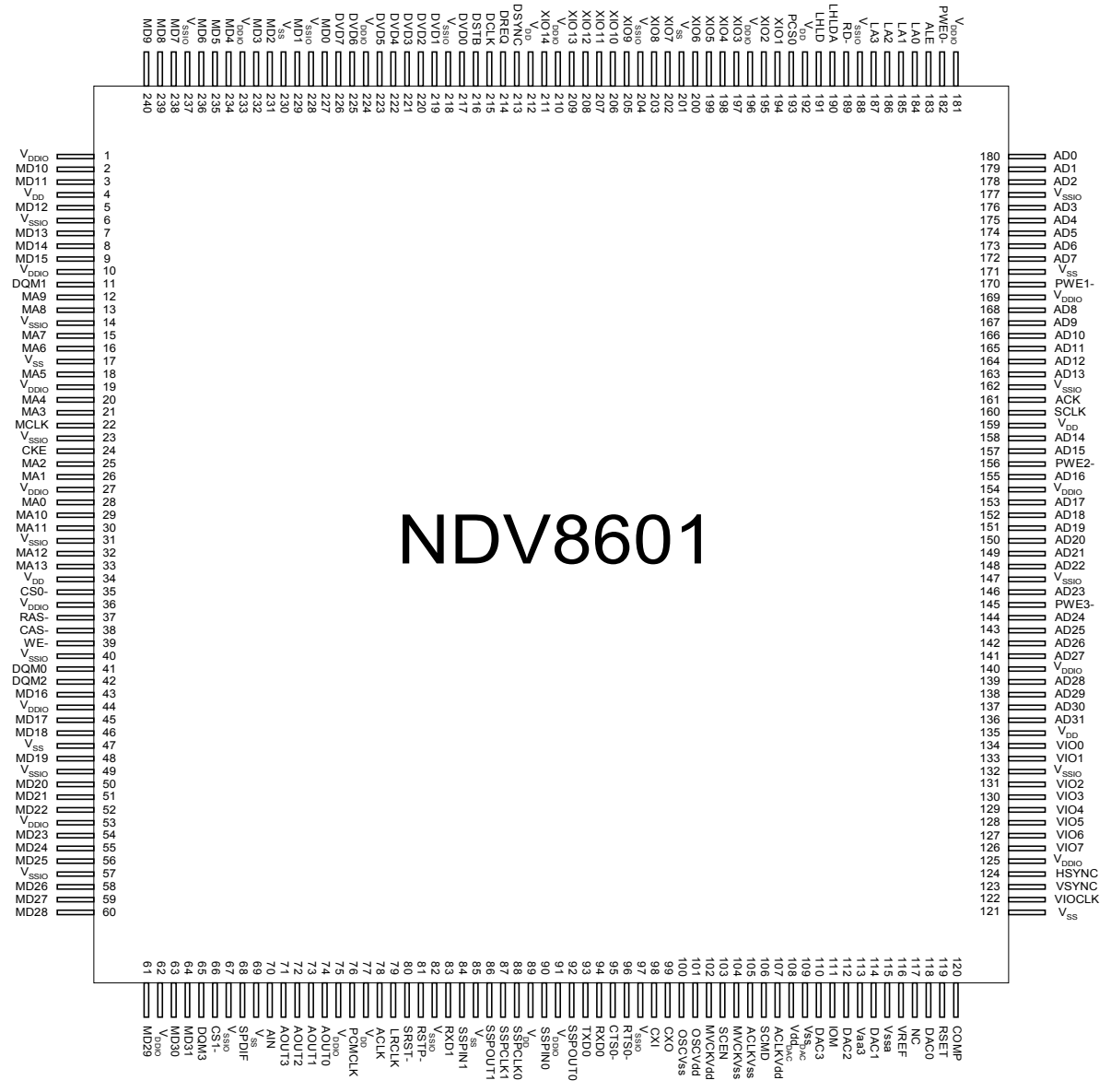

ELECTRICAL PARTS LIST

REF. NO.	PART NO.	DESCRIPTION			
SWITCH MODE POWER SUPPLY BOARD					
	16-57004-01	Switch Mode Power Supply			SMPS Raw PCB
	01-57004-01	Switch Mode Power Supply			SMPS PCB with components
DIODES					
D400, D401, D402, D403	33-20104-00	FR104			Fast Recovery Rectifier Diode
D405, D406, D407	33-20203-00	HER203			Fast Recovery Rectifier Diode
D410	33-15109-01	5.1V	1/2W		Zener Diode
D408	33-15609-01	5.6V	1/2W		Zener Diode
B400	33-30162-00	DB105			Rectifier Bridge
TRANSISTORS					
Q400, Q401, Q403, Q404, Q405, Q406	31-01815-00	2SC1815-GR			Transistor
Q407	31-01015-00	2SA1015-GR			Transistor
RESISTORS					
R404	07-20399-00	3.9Ω	1/6W	±5%	Metal Film Resistor
R405	07-20181-00	180Ω	1/6W	±5%	Metal Film Resistor
R433	07-20471-00	470Ω	1/6W	±5%	Metal Film Resistor
R408	07-20102-02	1KΩ	1/6W	±5%	Metal Film Resistor
R434	07-20222-00	2K2Ω	1/6W	±5%	Metal Film Resistor
R410	07-23301-00	3K3Ω	1/6W	±1%	Metal Film Resistor
R407	07-23601-00	3K6Ω	1/6W	±1%	Metal Film Resistor
R406	07-20392-02	3K9Ω	1/6W	±5%	Metal Film Resistor
R431, R432	07-20472-00	4K7Ω	1/6W	±5%	Metal Film Resistor
R415, R416, R417, R418, R419, R420, R421, R426, R427	07-20103-00	10KΩ	1/6W	±5%	Metal Film Resistor
R424, R425	07-20103-02	10KΩ	1/6W	±5%	Metal Film Resistor
R400, R401	07-20224-00	220KΩ	1/6W	±5%	Metal Film Resistor
R402	(07-20504-01)	(500KΩ NI)	1/6W	±5%	Metal Film Resistor
R403	07-30563-02	56K	2W	±5%	Metal Oxide Film Resistor
RT400	07-70050-00	5D-11			NTC
CAPACITORS					
C412, C413	05-10461-07	100nF, CL23B	63V	±10%	Polyester capacitor
C409, C410	05-10422-00	0.1uF, KNB1530	275V	±5%	Polyester capacitor
C403, C404	05-22142-00	220PF	400V	±10%	Ceramic Capacitor
C415	05-10313-01	10nF	1KV	±20%	Ceramic Capacitor
C416	05-10113-00	100PF	1KV	±10%	Ceramic Capacitor
C421	05-33242-00	3300PF	400V	±20%	Ceramic Capacitor
C405, C406, C407	24-47361-00	47nF	63V	±20%	Monolithic
C408, C423	06-47051-01	47uF, CD263X	50V	±20%	Alu Electrolytic Capacitor
C428, C433	06-10111-03	100uF, CD263X	16V	±20%	Alu Electrolytic Capacitor
C429, C432	06-10121-02	100uF, CD263X	25V	±20%	Alu Electrolytic Capacitor
C400	06-10142-00	100uF, CD293	400V	±20%	Alu Electrolytic Capacitor
C422	06-22111-05	220uF, CD263X	16V	±20%	Alu Electrolytic Capacitor
C434	06-33111-02	330uF, CD263X	16V	±20%	Alu Electrolytic Capacitor
C435	06-33121-00	330uF, CD263X	25V	±20%	Alu Electrolytic Capacitor
C417, C418, C419	06-10221-01	1000uF, CD263X	25V	±20%	Alu Electrolytic Capacitor

ELECTRICAL PARTS LIST

REF. NO.	PART NO.	DESCRIPTION			
INDUCTORS					
L401, L403, L404	08-02220-01	LGB-S0810-220K, 22uH			Inductor
L400	22-00025-10	LCL-25A, 48mH			Filte Inductor
FB403, FB404, FB405, FB409, FB410, FB411	19-35980-00	FB			Ferrite Bead
FB400, FB401, FB402, FB406	19-35980-01	FB			Ferrite Bead
ICS					
U401	03-00817-00	PC817B			Photocoupler
U402	03-00431-00	TL431			Regulator IC
U407	03-07805-10	KA78R05TU			Regulator IC
U405	03-07809-10	KA78R09TU			Regulator IC
U404	03-07833-10	KA78R33			Regulator IC
U400	03-50365-00	KA5M0365RYDTU			Power Switch IC
FUSES					
F401	31-00010-00	ICP N10			Protector IC
	20-12202-00	T2AL/250V			Fuse
FH400	20-20000-01	HF-003-1			Fuse Holder
TRANSFORMERS					
T400	18-57030-00	BCK-08A10			Transformer
CONNECTORS					
J409	13-22003-00	PH 2.0A-3A			Connector
J406	13-22004-00	PH 2.0A-4A			Connector
J404, J407, J408	13-22006-00	PH 2.0A-6A			Connector
J400, J401, J402, J403	13-23903-01	VH 3.96A-3Y1 (Remove the middle pin)			Connector
OTHERS					
W402, R412, R414	21-06500-00	L=5mm			Links
D409	21-06650-00	L=6.5mm			Links
W403, W404, W405, W406, W407, W408, R411, R413	21-06750-00	L=7.5mm			Links
W401	21-10750-00	L=7.5mm			Links
C420	21-06101-00	L=10mm			Links
ANALOG POWER SUPPLYBOARD					
	16-57004-02	Analog Power Supply Board			Analog PS Raw PCB
	01-57004-02	Analog Power Supply Board			Analog PS PCB with components
DIODES					
B800	33-30162-00	DB105			Bridge
TRANSISTOR					
Q801	31-01815-00	2SC1815-GR			Transistor
Q802	31-01015-00	2SA1015-GR			Transistor
Q800	31-00669-00	2SD669AWC			Transistor
RESISTORS					
R801, R802, R803, R804	07-20103-00	10KΩ	1/6W	±5%	Metal Film Resistor

ELECTRICAL PARTS LIST

REF. NO.	PART NO.	DESCRIPTION			
CAPACITORS					
C800, C801, C803, C804, C805	05-10461-07	100nF, CL23B	63V	±10%	Polyester capacitor
C809, C810	06-33121-00	330uF, CD263	25V	±20%	Alu Electrolytic Capacitor
C807, C808	06-33151-00	330uF, CD263	50V	±20%	Alu Electrolytic Capacitor
C806	06-47151-00	470uF, CD263	50V	±20%	Alu Electrolytic Capacitor
INDUCTORS					
L800, L801	08-02220-01	LGB-S0810-220K, 22uH			Inductor
ICS					
U801	03-07812-10	KA78R12			Regulator IC
U802	03-07912-00	LM7912/MC7912/KA7912			Regulator IC
TRANSFORMERS					
T401	18-57015-00	R20(C VERSION)			R-Transformer
T401	18-57015-01	R20(AH VERSION)			R-Transformer
CONNECTORS					
J802	13-22003-00	PH 2.0A-3A			Connector
J801	13-22004-00	PH 2.0A-4A			Connector
J800	13-22005-00	PH 2.0A-5A			Connector
OTHERS					
R800	21-06500-00	L=5mm			Links
CONTROL BOARD					
	16-57003-01	Control			Control Raw PCB
	01-57003-00	Control			Control PCB with components
DIODES					
D301, D302, D303, D304, D305, D307	33-44148-03	1N4148			Switch Diode
D311, D313, D314	33-50360-00	RT3-6134B2S-B			LED Blue
TRANSISTORS					
Q300, Q301	31-01815-00	2SC1815-GR			Transistor
RESISTORS					
R306	07-20101-10	100Ω	1/4W	±5%	Metal Film Resistor
R300, R304	07-20102-10	1KΩ	1/4W	±5%	Metal Film Resistor
R319	07-20472-10	4K7Ω	1/4W	±5%	Metal Film Resistor
R303, R305, R308, R309, R310, R311, R313, R314, R315, R316, R320, R321, R322	07-20103-10	10KΩ	1/4W	±5%	Metal Film Resistor
R302, R307	07-20473-10	47KΩ	1/4W	±5%	Metal Film Resistor
R301, R312, R317, R318	07-20471-10	470Ω	1/4W	±5%	Metal Film Resistor
CAPACITORS					
C306, C307, C308, C309, C310	24-10161-00	100PF	63V	±20%	Monolithic
C303, C304, C305	24-10461-00	0.1uF	63V	±20%	Monolithic
C301	06-10011-04	10uF, CD11E	16V	±20%	ALU Electrolytic Capacitor
C302	06-10051-04	10uF, CD11E	50V	±20%	ALU Electrolytic Capacitor
C311	06-22111-06	220uF, CD11E	10V	±20%	ALU Electrolytic Capacitor

ELECTRICAL PARTS LIST

REF. NO.	PART NO.	DESCRIPTION	
ICS			
U301	23-56119-00	20U39119BAN	VFD
U302	03-16312-01	UPD16312GB-3B4	VFD Driver IC
U302	or 03-00792-00	or S0792GB	VFD Driver IC
U303	03-00038-00	HS0038B	IR Sensor IC
SWITCHES			
SW302, SW303, SW307, SW308, SW309, SW310, SW311, SW313, SW314, SW315, SW316, SW317, SW319 SW320 SW322	11-04101-04	IT-1102-1260	Tact Switch
CONNECTORS			
J303-J4	14-57008-00	L=80mm, 8Pin	Connector
J301-J404	14-57006-00	L=80mm, 6Pin	Connector
J304-J502	14-57006-11	L=300mm, 6Pin	Connector
DECODE BOARD			
	16-56002-00	Decode	Decode Raw PCB
	01-57002-20	Decode(C Version)	Decode PCB with components
	01-57002-10	Decode(AH Version)	Decode PCB with components
ICS			
U13, U18	03-00800-01	MX29LV800BTC-90/ or AM29LV800BB-90EC/or AM29LV800BT-90EC	Flash IC
U10, U15	03-00573-01	74LCX573MTC/ or MC74LCX573DT	Logic Gate IC
U1	03-00541-01	74VHCT541AMTC/ or MC74VHCT541ADT	Logic Gate IC
U6, U7	03-00574-01	74VHCT574AMTC/ or MC74VHCT574ADT	Logic Gate IC
U22	03-65322-01	HY57V653220B7/ or [HY57V651620B7]/ or W986432DH-7	SDRAM IC
U2	03-00809-01	LM809M3-2.63	Regulator IC
U3	03-03965-01	LP3965EMP-1.8	Regulator IC
U5	03-08601-01	NDV8601VWA	PANTARA-2 DECODER IC
U4	03-09346-01	NM93CS46LZEM8 or 93LC46B/SN	EEPROM IC

ELECTRICAL PARTS LIST

REF. NO.	PART NO.	DESCRIPTION			
CAPACITORS					
C100-C110, C12, C121-127, C20, C23, C30, C35, C41, C42, C44-51, C53-C65, C7, C76, C77, C81, C88-C91, C84	26-10451-00	0603, 100nF (Y5V)	50V	+80%-20%	Cermatic Capacitor SMD
C14, C15, C16, C33	26-10251-00	0603, 1nF (X7R)	50V	±10%	Cermatic Capacitor SMD
C29	26-15051-00	0603, 15pF (NPO)	50V	±5%	Cermatic Capacitor SMD
C1, C4, C8, C13	26-20051-00	0603, 20pF (NPO)	50V	±5%	Cermatic Capacitor SMD
C28	26-27051-00	0603, 27pF (NPO)	50V	±5%	Cermatic Capacitor SMD
C67, C68, C69	26-47051-00	0603, 47pF (NPO)	50V	±5%	Cermatic Capacitor SMD
C6, C10, C19, C111	26-10151-00	0603, 100P (NPO)	50V	±5%	Cermatic Capacitor SMD
C5, C9, C18	26-15151-00	0603, 150PF (NPO)	50V	±5%	Cermatic Capacitor SMD
C3, C36, C37, C38, C39	26-22151-00	0603, 220PF (NPO)	50V	±5%	Cermatic Capacitor SMD
C2	26-33151-00	0603, 330PF (NPO)	50V	±5%	Cermatic Capacitor SMD
C52, C66, C86, C87	06-10060-01	10uF, CDVS	6.3V		Alu Electrolytic Capacitor SMD
C31, C112	06-10160-01	100uF, CDVS	6.3V		Alu Electrolytic Capacitor SMD
C114, C115, C128	06-10111-02	100uF, CA45	10V		Tan Electrolytic Capacitor SMD
C25	06-47160-01	470uF, CDVS	6.3V		Alu Electrolytic Capacitor SMD
INDUCTORS					
L2, L3, L4	08-04109-00	CMI321611U1R0KT			Inductor SMD
L1, L11, L12	08-04229-00	CMI321611U2R2KT			Inductor SMD
L9	08-04100-01	CMI321611X100KT			Inductor SMD
L6, L8	08-04119-00	CBG201209U110T	0805		Ferrite Bead
RESISTORS					
R15, R17, R231, R232, R233, R237, R62, R8, R77, R92, R98	07-90000-00	0Ω	0603	±5%	Resistor SMD
R19	07-90100-00	10Ω	0603	±5%	Resistor SMD
R20, R26	07-90220-00	22Ω	0603	±5%	Resistor SMD
R49, R50, R51	07-90470-00	47Ω	0603	±5%	Resistor SMD
R78, R2, R3, R4, R5	07-90750-00	75Ω	0603	±5%	Resistor SMD
R14	07-90331-00	330Ω	0603	±5%	Resistor SMD
R32, R39	07-90152-00	1.5kΩ	0603	±5%	Resistor SMD
R59	07-90332-00	3.3kΩ	0603	±5%	Resistor SMD
R33-R35, R37, R38, R41-48, R93	07-90103-00	10kΩ	0603	±5%	Resistor SMD
R10	07-90104-00	100kΩ	0603	±5%	Resistor SMD
R96, R1	07-91500-00	150Ω	0603	±1%	Resistor SMD
R18	07-91101-00	1.1kΩ	0603	±1%	Resistor SMD
RP1, RP2, RP3, RP8, RP9, RP10, RP11, RP12	07-90220-01	4×22Ω PACK	RCML08W		Resistor SMD
CONNECTORS					
J4	13-22008-00	S8B-PH-SM3-TB			Connector
J3	13-22007-00	S7B-PH-SM3-TB			Connector
J2	13-21016-01	52207-1690			FFC/FPC Connector
J6	13-21024-01	52207-2490			FFC/FPC Connector
J16	13-21022-00	52610-2290 or 2434-22TD3			FFC/FPC Connector
CRYSTALS					
Y1	04-12702-02	27.000MHZ	CL=15P		CRYSTAL SMD

ELECTRICAL PARTS LIST

REF. NO.	PART NO.	DESCRIPTION			
AUDIO BOARD					
	16-56001-00	Audio	Audio Raw PCB		
	01-57001-20	Audio(C Version)	Audio PCB with components		
	01-57001-10	Audio(AH Version)	Audio PCB with components		
DIODES					
D601, D602	33-40054-01	BAT54ACTor BAT54ALT1	Schottky Barrier Diode		
D603	33-40054-00	BAT54S	Schottky Barrier Diode		
D605	33-44148-06	1N4148(C Version)	Switch Diode		
TRANSISTORS					
Q601, Q602, Q603, Q604, Q605, Q606, Q607, Q608	31-02216-00	UN221600L	Transistor		
Q609, Q610, Q611	31-00710-00	2SB0710A0L	Transistor		
Q501	31-01015-00	2SA1015-GR	Transistor		
Q502	31-01815-00	2SC1815-GR	Transistor		
ICS					
U608	03-05622-01	CLC5622IM	IC, Video Amplifier		
U608	or 03-04016-00	or MAX4016ESA	IC, Video Amplifier		
U607	03-05623-01	CLC5623IM	IC, Video Amplifier		
U607	or 03-04018-01	or MAX4018ESD	IC, Video Amplifier		
U610	03-02604-01	OPA2604AU	IC, Opamp.		
U609	03-08716-01	XWM8716EDS	IC,DAC		
U615	03-00337-01	LM337IMP	IC, Regulator		
U605, U612	03-01117-01	LM1117MP-5.0	IC, Regulator		
U611	03-01117-02	LM1117MP-ADJ	IC, Regulator		
U613	03-03480-01	LM3480IM3-5.0	IC, Regulator		
U614	03-00550-00	GP1FA550TZ	Fiber Optic Transmitter		
CAPACITORS					
C638, C648-C651, C654, C656-677, C705-C707, C720, C730	26-10451-00	0603,100nF (Y5V)	50V	+80%- 20%	Cermatic Capacitor SMD
C691, C692, C693	26-10251-00	0603, 1nF (X7R)	50V	±10%	Cermatic Capacitor SMD
C680- C689	26-20051-00	0603, 20pF (NPO)	50V	±5%	Cermatic Capacitor SMD
C703, C704, C709	26-10151-00	0603, 100PF (NPO)	50V	±5%	Cermatic Capacitor SMD
C701, C702, C726-C729	26-22151-00	0603, 220PF (NPO)	50V	±5%	Cermatic Capacitor SMD
C698, C700	26-39151-00	0603, 390PF (NPO)	50V	±5%	Cermatic Capacitor SMD
C678, C679, C715, C716	26-68151-00	0603, 680P (NPO)	50V	±5%	Cermatic Capacitor SMD
C607, C609, C615-C618, C634-C637	06-10011-01	10UF, ELNA Series	16V		Alu Electrolytic Capacitor
C711, C712	06-47011-01	47UF, ELNA Series	10V		Alu Electrolytic Capacitor
C717, C718	06-47011-02	47UF, ELNA Series	10V		ALu Electrolytic Bi-polar Capacitor
C690, C694-C697	06-47111-02	470UF, ELNA Series	10V		Alu Electrolytic Capacitor
C719, C722, C723, C724	06-10111-01	CD110X, 100UF	16V	±20%	Alu Electrolytic Capacitor
C710	06-47111-01	CD110X, 470UF	10V	±20%	Alu Electrolytic Capacitor
C725	06-10260-00	CD110X, 1000UF	6.3V	±20%	Alu Electrolytic Capacitor
INDUCTORS					
L601, L602	08-04100-00	FHW1008IF100JST	1206		Inductor SMD

ELECTRICAL PARTS LIST

REF. NO.	PART NO.	DESCRIPTION			
RESISTORS					
R506, R508, R702, R703, R608	07-90000-00	0Ω	0603	±5%	Resistor SMD
FB602-FB613, FB625	07-90000-01	0Ω	0805	±5%	Resistor SMD
R696, R697, R698	07-90220-00	22Ω	0603	±5%	Resistor SMD
R500, R502	07-90101-00	100Ω	0603	±5%	Resistor SMD
R710, R711	07-90111-00	110Ω	0603	±5%	Resistor SMD
R610, R611, R706	07-90151-00	150Ω	0603	±5%	Resistor SMD
R603, R604	07-90331-00	330Ω(C Version)	0603	±5%	Resistor SMD
R504, R507	07-90471-00	470Ω	0603	±5%	Resistor SMD
R652-R656, R707	07-90681-00	680Ω	0603	±5%	Resistor SMD
R616, R617	07-90102-00	1kΩ(C Version)	0603	±5%	Resistor SMD
R627, R628	07-90152-00	1.5kΩ	0603	±5%	Resistor SMD
R501, R503, R510, R631, R633, R639, R651	07-90103-00	10kΩ	0603	±5%	Resistor SMD
R695	07-90104-00	100kΩ	0603	±5%	Resistor SMD
R657, R658-R661, R663- R666, R668, R670-R672,	07-97509-00	75Ω	0603	±1%	Resistor SMD
R662, R667, R669	07-91000-00	100Ω(C Version)	0603	±1%	Resistor SMD
R705	07-92400-00	240Ω	0603	±1%	Resistor SMD
R605, R673, R674, R680	07-94700-00	470Ω	0603	±1%	Resistor SMD
R675-R679, R681-R684	07-95100-00	510Ω	0603	±1%	Resistor SMD
R708	07-97200-00	720Ω	0603	±1%	Resistor SMD
R686, R687	07-93321-00	3.32kΩ	0603	±1%	Resistor SMD
R685, R688	07-93831-00	3.83kΩ	0603	±1%	Resistor SMD
R693, R694	07-97501-00	7.5kΩ	0603	±1%	Resistor SMD
R699, R609	07-94701-00	4.7kΩ	0603	±1%	Resistor SMD
R689, R690-R692	07-91002-00	10kΩ	0603	±1%	Resistor SMD
CONNECTORS					
J608	13-21016-00	PD05-161			Connector
J612	13-21024-00	PD05-241			Connector
J501	17-07001-00	PY301-030-100			Phone Jack
J500	17-02001-01	ST-301-030-100			Stero Phone Jack
J610	17-04005-00	SW-2			Connector
J609	17-01001-01	DAV-8.4-14PB			Connector RCA
J614	17-01001-02	DAV-8.4-14PB			Connector RCA
J611	17-01002-02	DAV ₂ -8.4-13PB			Connector RCA
J607	17-01003-00	DAV ₃ -8.4-13PB			Connector RCA
J606	17-10021-00	D-21-3(C Version)			Scart Connector
J503, J613	13-22004-00	2.0A-4A			Connector
J502	13-22006-00	2.0A-6A			Connector
SWITCHES					
SW601, SW500(AH VERSION)	11-05202-05	DPDT/SSH-22H03G4			SLIDE SWITCH

SERVICE MANUAL

S570

**DVD / VCD / CD
PLAYER**

© NAD 2003

**NAD ELECTRONICS INTERNATIONAL
CANADA**