

Smartfind M10
AIS Transponder
User Manual

General Information

i. **Copyright**

The entire contents of this instruction manual, including any future updates, revisions, and modifications, shall remain the property of Orolia Ltd at all times. Unauthorized copies or reproduction of this manual, either in part or whole, in any form of print and electronic media, is prohibited. The contents herein can only be used for the intended purpose of this manual.

ii. **Disclaimer**

The information and illustrations contained in this publication are to the best of our knowledge correct at time of going to print. We reserve the right to change specifications, equipment, installation and maintenance instructions without notice as part of our policy of continuous product development and improvement. No part of this publication may be reproduced, stored in a retrieval system or transmitted in any form, electronic or otherwise without permission in writing from Orolia Ltd. No liability can be accepted for any inaccuracies or

omissions in the publication, although every care has been taken to make it as complete and accurate as possible.

This manual is applicable for McMurdo Smartfind M10 devices manufactured after October 2013.

iii. **Safety Warning**



It is important to know that AIS is designed for the purpose of anti-collision and serves to complement navigation. It is not the absolute navigational equipment and does not replace any navigational system installed on board.



Any AIS device cannot guarantee monitoring and receiving signals from all vessels in the surroundings unless those vessels are equipped with AIS devices.



Never Switch on the AIS transponder without a VHF antenna connected.

RF Exposure Warning

WARNING: This device generates and radiates RF electromagnetic energy. This device must be installed and operated according to the instructions contained in this manual. Failure to do so may result in product malfunction and/or exposure to potentially harmful levels of radio frequency radiation.

WARNING: Never operate this device unless it is properly connected to a VHF antenna. To maximise performance and minimise human exposure to RF energy, always mount the antenna at least 3m from the device.



The system has a Maximum Permissible Exposure (MPE) radius of 60cm from the antenna. This has been determined assuming the maximum power of the transmitter and using a standard half-wave monopole VHF antenna with a maximum gain of 3dBi and termination impedance of 50 ohms.

When installing the antenna and operating the

equipment consider the following:

- The antenna should be mounted at a minimum vertical distance of 5m above the deck in order to meet international safety directives on Maximum Permissible Exposure (MPE). Failure to adhere to these limits could expose persons within the 60cm radius to RF radiation in excess of the recommended MPE limits.
- Higher gain VHF antennas will require a larger MPE radius.
- Do not operate the unit when anyone is within the MPE radius of the antenna.
- The antenna should not be co-located or operated in conjunction with any other transmitting antenna.

Wi-Fi Antenna warning for M10W



Ensure that a minimum separation distance of 20cm is maintained between the Wi-Fi antenna and any personnel in the vicinity.



CORRECT POWER SOURCE

An incorrect power source will damage the equipment and may even result in a fire. Ensure that the correct power source is provided at all times.



AVOID DIRECT CONTACT WITH RAIN OR SPLASHING WATER

Electrical shock or fire could be resulted if water leaks into the equipment.



AVOID USING CHEMICAL SOLVENTS TO CLEAN THE CASE

As some solvents can damage the case material.



NOTE/INFORMATION

Throughout this manual this symbol indicates important information.

iv. **Product Category**

This product is categorized as “protected” in accordance with the requirements as defined in IEC 60945.

v. **Hardware / Software Version**

The model name, number, hardware information, and firmware (software) version of the transponder can be identified by using the McMurdo AIS CLASS B Configurator tool supplied. The software maintenance/upgrade of the transponder can be

carried out on board via an USB interface and connection to a PC or laptop.

vi. **EC Declaration of Conformity**

Hereby, Orolia Ltd declares that the Types Z602 & Z603 are in compliance with the essential requirements and other relevant provisions of the of Directive 1999/5/EC. A copy of the Declaration of Conformity can be obtained on-line from:



www.mcmurdomarine.com/documents

Use of this equipment requires an user licence. It may be operated in the following EC countries:

| | | | | | |
|----|----|----|----|----|----|
| AT | CY | CZ | DK | EE | FI |
| FR | DE | GR | HU | IE | IT |
| LV | LT | LU | NL | PL | PT |
| SK | ES | SE | GB | IS | LI |
| NO | CH | BG | RO | TR | MT |

vii. **FCC Interference Statement**

NOTE: This equipment has been tested and found to comply with the limits for a Class A digital device, pursuant to part 15 of the FCC Rules. These limits are designed to provide reasonable protection against harmful interference when the equipment is operated in a commercial environment. This equipment generates, uses, and can radiate radio frequency energy and, if not installed and used in accordance with the instruction manual, may cause harmful interference to radio communications. Operation of this equipment in a residential area is likely to cause harmful interference in which case the user will be required to correct the interference at his own expense.

This device complies with Part 15 of the FCC Rules. Operation is subject to the following two conditions:

- 1) This device may not cause harmful interference, and

- 2) This device must accept any interference received, including interference that may cause undesired operation

viii. **Disposal Instruction**

The Waste Electrical and Electronic Equipment (WEEE) Directive aims to minimize any adverse impact of electronic equipment on the environment, both during the product lifetime and when it becomes waste. Within the European Union this legislation is mandated by Directive 2002/96/EC, and there is similar legislation in most other continents. The directive applies to all electronic products such as IT, household appliances, portable electronics etc., and imposes requirements to collect, treat, recover and recycle each product at its end of life. Electronic end-user products must also carry a WEEE label (as below) and recovery and recycling information has to be provided to the recycler.



ix. **IMO Green Passport Ship Recycling Information**

Orolia Ltd hereby declares potentially hazardous content in some of its electronic products. Small amounts of the following substances may be present: beryllium oxide, lithium, lead, brominated flame retardants, glass. In keeping with European directive 2002/96/EC (Waste Electronic and Electrical Equipment) and the provisions of IMO Resolution A.962(23) (Guidelines On Ship Recycling), Orolia Ltd strongly recommends that its products, including any battery packs, be disposed of in a considerate and legal manner.

x. **Maintenance**

All servicing must be carried out by an Orolia Ltd. approved service agent. Always call your nearest agent and talk to their service department before returning equipment. You can find your nearest service agent from:

i The McMurdo web site: *www.mcmurdomarine.com*

- i Contacting Orolia Ltd. direct (see warranty page).
- i Contacting a McMurdo distributor

Contact Information

For sales, services, and technical supports, please contact your local Orolia Ltd representatives or Orolia Ltd at

www.mcmurdomarine.com or

sales.mcmurdo@orolia.com or

service.mcmurdo@orolia.com

xi. **Licensing and Maritime Mobile Service Identity (MMSI)**

IMPORTANT: In most countries the operation of an AIS unit is included under the vessel's marine VHF licence provisions. The vessel on to which the AIS unit is to be installed must therefore possess a current VHF radiotelephone licence which lists the AIS system and the vessel Call Sign and MMSI number. An MMSI number is required in order for the device to operate.

Please contact the relevant authority in your country for more information.

WARNING!

- WARNING:** The transponder must be installed and configured in conformity with the provided instructions in the manual in order to maximize the device performance.
- WARNING:** Please bear in mind that not all vessels are equipped with AIS transponders and therefore may not be visible to this transponder. Likewise, certain conditions, such as device malfunction, the environment, improper use, and overcrowded port traffic, may exist whereby the vessel equipped with this AIS transponder is not visible to other AIS transponders.
- WARNING:** DO NOT DISASSEMBLE OR MODIFY THE EQUIPMENT. Improper disassembly or modification could cause personal injury and will invalidate the guarantee.
- WARNING:** While most of the installation can be performed by the owner or the crew, a final commissioning can be done by your local agent/dealer when needed or required. Orolia and the local agent/dealer will not bear any responsibilities over any damages resulted from improper installation by an unauthorized agent/dealer.

FOR USERS IN THE UNITED STATES OF AMERICA ONLY

WARNING: It is a violation of the rules of the Federal Communications Commission to input an MMSI that has not been properly assigned to the end user, or to otherwise input any inaccurate data in this device.

- ★ The entry of static data into this device shall be performed by the vendor of the device or by an appropriately qualified person in the business of installing marine communications equipment on board vessels.
- ★ Instructions on how to accurately enter and confirm static data in the device can be found in this user manual.

TABLE OF CONTENT

| | | |
|----------|---|-----------|
| 1 | WHAT IS AIS? | 1 |
| 1.1 | AIS CLASS B MESSAGE TYPES | 3 |
| 1.2 | AIS REPORT RATE | 4 |
| 2 | SYSTEM OVERVIEW | 5 |
| 2.1 | PRODUCT DESCRIPTION..... | 5 |
| 2.2 | EQUIPMENT IN THE BOX | 7 |
| 2.3 | EXTERNAL CONNECTIONS | 8 |
| 3 | PROGRAMMING YOUR VESSEL DATA | 9 |
| 3.1 | USB DRIVER INSTALLATION | 9 |
| 3.2 | AIS CONFIGURATION SOFTWARE INSTALLATION | 10 |
| 4 | INSTALLATION | 12 |
| 4.1 | INSTALLATION PROCEDURES | 12 |

| | |
|---|-----------|
| 4.2 MOUNTING THE M10 UNIT | 13 |
| 4.4 VHF ANTENNA INSTALLATION | 15 |
| 4.5 GPS ANTENNA INSTALLATION | 16 |
| 4.6 CONNECTING POWER AND DATA CABLE | 18 |
| 4.7 CONNECTING WITH NMEA0183 DEVICES | 20 |
| 4.8 AIS TX SILENT MODE | 25 |
| 4.9 CONNECTING TO A POWER SUPPLY | 25 |
| 4.10 CONNECTION TO NMEA2000 NETWORK | 26 |
| 5 GET STARTED | 27 |
| 5.1 START UP THE TRANSPONDER | 27 |
| 5.2 LED INDICATORS | 28 |
| 5.3 SD CARD DATA LOGGING | 29 |
| 5.4 WI-FI CONFIGURATION (M10W ONLY) | 30 |

| | |
|---|-----------|
| 5.5 BUILT-IN INTEGRITY TEST (BIIT) | 32 |
| 5.6 AIS VIEWER DESCRIPTION | 33 |
| 6 SPECIFICATIONS | 35 |
| 6.1 PRODUCT SPECIFICATIONS | 35 |
| 6.2 DIMENSIONS | 43 |
| 6.3 NMEA 2000 PGN INFORMATION | 44 |
| 7 TROUBLESHOOTING | 46 |
| 8 ABBREVIATIONS | 50 |
| 9 AIS INFORMATION | 51 |
| 9.1 CLASS A VS. CLASS B AIS | 51 |
| 10OROLIA LTD WORLDWIDE WARRANTY | 53 |

1 What is AIS?

The Automatic Identification System (AIS) is a Very High Frequency (VHF) radio broadcasting system that transfers packets of data over the VHF data link (VDL) and enables AIS equipped vessels and shore-based stations to exchange identification information and navigational data. Ships with AIS transponders continually transmit their ID, position, course, speed and other data to all nearby ships and shore stations. Such information can aid greatly in situational awareness and provide a means to assist in collision avoidance.

AIS equipment is standardized by ITU, IEC, IALA and IMO and is subject to approval by a certification body. The following AIS devices have been developed for various applications.

■ **AIS Class A:**

mandated by the IMO for vessels of 300 gross tonnages and upwards, engaged on international voyages, cargo ships of 500 gross tonnages and upwards, as well as passenger ships. It typically transmits using 12.5W output power.

■ **AIS Class B:**

provides limited functionality and is intended for non-SOLAS commercial vessels and recreational vessels. It typically transmits using 2W output power.

- **AIS Base Station:**

is provided by aids-to-navigation authorities to enable the ship to shore / shore to ship transmission of information. Networked AIS Base Stations can assist in providing overall maritime domain awareness.

- **AIS AtoN (Aids to Navigation):**

provides an opportunity to transmit position and status of buoys and lights through the same VDL, which can then show up on AIS-ready devices within range.

- **AIS SART:**

Search and Rescue Transmitter using AIS can be used to assist in determining the location of a vessel in distress. It is typically used on life rafts.

- **AIS MOB**

Man Overboard transmitter or personal AIS beacon, used to assist in survivor recovery.

- **AIS on Search and Rescue (SAR) Aircraft:**

used on airplanes and helicopters to assist search and rescue operation.

1.1 AIS Class B Message Types

Class B AIS broadcasts following message types:

Static Data:

- i MMSI
- i Vessel name
- i Vessel call sign
- i Type of ship
- i Ship dimensions / GPS antenna location

Dynamic Data:

- i Position of the vessel
- i Course over ground (COG)
- i Speed over ground (SOG)
- i True heading

1.2 AIS Report Rate

Class B AIS devices broadcast the ships dynamic data as per the following reporting interval table.

| Ship Condition | Nominal Reporting Interval |
|-------------------------------------|-----------------------------------|
| Ship not moving faster than 2 knots | 3 Minutes |
| Ship moving faster than 2 knots | 30 Seconds |

Additionally the ships static data will be broadcasted every 6 minutes.

2 System Overview

2.1 Product Description

The McMurdo Smartfind M10 AIS Class B Transponder is perfect for smaller vessels, where the complexity of a Class A Transponder is not necessary. It transmits the vessels dynamic and static information, as well as receiving all AIS targets within 20 miles of the boat, typically. Using the built-in GPS receiver, the Smartfind M10 determines position, speed and course, and once this is combined with other navigational information, it is automatically transmitted without any user interaction. When received by other vessels and coast stations, the data built up will provide a live graphical display of traffic in the area. The McMurdo M10 has been engineered for flawless integration with navigation systems, and supports NMEA2000 and NMEA0183 communications, and its output meets IEC 62287 and related standards. The M10 also features USB connectivity and an optional WiFi interface (M10W). The SD card slot in the Smartfind M10, can be quickly and easily used as a data recorder, enabling the capture of all messages - to assist in system and safety monitoring, including incident investigation. The recorded data is logged and stored on the SD card when fitted. A 'Silent' mode allows the user to stop the broadcast of static and dynamic information on occasions where either privacy or security is required.

Key Features:

- **High performance AIS Class B transponder**
- **Dual-channel AIS receiver with DSC**
- **NMEA2000 and NMEA0183 connectivity**
- **Mini USB-B socket**
- **SD data logger card slot**
- **Built in high-sensitivity GPS receiver with GPS antenna included**
- **Optional silent mode (suspends AIS transmissions)**
- **Compact and stylish design**
- **Low power consumption, 12 to 24V DC power supply**
- **Supplied with AIS Viewer and Configuration software for use on a PC**

2.2 Equipment in the Box

Upon receiving the product please verify all the items are in the box. If any items are missing, please contact your local Orolia Ltd representative immediately.



Class B AIS Transponder

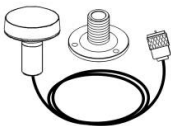

GPS antenna ANT-21 with 10m cable and mounting bracket



M3.5x25 Screws

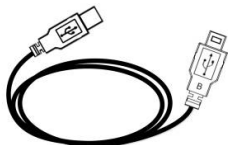

Mini USB to USB cable, 1.8m

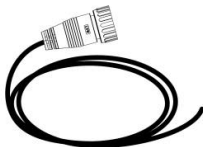

12pin cable with power, dual NMEA0183, silent mode, 1m, 26AWG

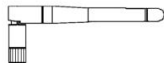

Wi-Fi antenna
(M10W Only)



Software CD: configuration utility, USB driver, AIS Viewer, user manual



User Manual

2.3 External Connections

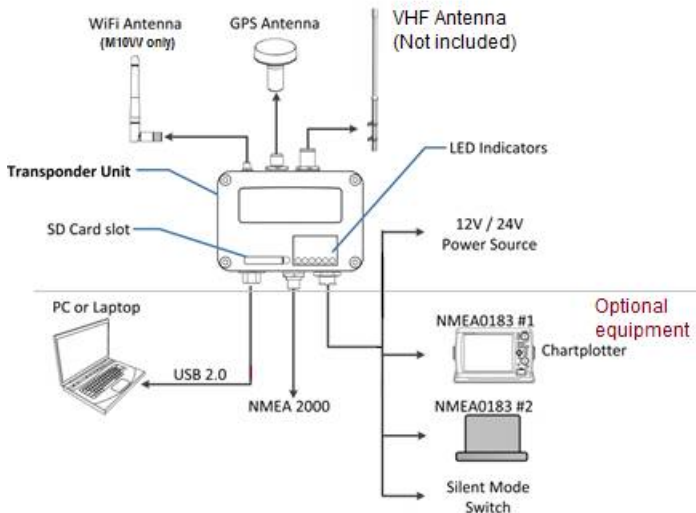

3 Programming Your Vessel Data

To program your vessel data requires the use of a PC/Laptop computer with a spare USB connection and CD-ROM drive.

3.1 USB Driver Installation

The PC USB driver should be installed before configuring the vessel data with the AIS Configuration Software. A PC/laptop can also be a convenient platform to display AIS targets with compatible software like the AIS Viewer supplied.

Required Items

- i USB Driver (included in the software CD)
- i USB cable (included in the box)
- i PC/Laptop with Windows operating system (not included, currently the Smartfind M10 USB Driver supports Windows XP, Windows Vista, and Windows 7).
- i One available USB port on PC/Laptop
- i Available CD-ROM drive on PC/Laptop

Driver Installation

With the transponder power on and the USB cable attached, plug in the USB cable to the PC/Laptop. A new hardware found prompt will show up. Follow the

on screen instructions and assign the correct file path of the USB driver to complete the installation. You can also install the USB driver via the Device Manager in the Control Panel, (detailed USB driver installation instructions are supplied on the CD with the USB driver).

3.2 AIS Configuration Software Installation

The McMurdo Class B Configuration software enables the user to set up the transponder by entering your own ship's information. It also provides the facilities to monitor and diagnose your transponder from your PC/Laptop

The McMurdo AIS Configuration program can be found on the CD supplied. To install the configuration software follow the installation instructions below.

Open the McMurdo AIS Configuration file on the CD and click on the setup  icon to start the installation process. Follow the on screen instructions to complete the installation and check the checkbox to start the McMurdo AIS Configuration at the end of the installation.

Once the Configuration Software is launched, you can establish the connection with PC either automatically or manually by assigning the COM port and baud rate of the port.

As soon as the transponder has a successful connection, click on the "STATIC DATA" tab. You will require the following information in order to configure your AIS transponder:

- Vessel name: limited to 20 characters
- Call sign: limited to 7 characters
- MMSI: Enter your MMSI (Maritime Mobile Service Identity) number
- Vessel type: choose your ship type from the drop down list
- Vessel dimensions and position of your GPS antenna installation



WARNING: The MMSI number can only be entered once, be sure to enter the correct MMSI number, as it cannot be corrected if entered incorrectly.

4 Installation

4.1 Installation Procedures

Please familiarize yourself with the manual content before beginning the installation. Depending on your hardware configuration, use the following recommended steps for installation.

- 1) Mount the transponder unit in an appropriate location (see section 4.2)
- 2) Install VHF antenna
- 3) Install GPS antenna
- 4) Connect the antenna cables to the transponder unit
- 5) Make silent mode connection if applicable (optional external switch needed)
- 6) Connect to an appropriate power source (12V / 24V DC, 2A)
- 7) Power On the power source (which turns on the transponder unit)
- 8) Program MMSI and vessel information into the device using the configuration software before installation
- 9) Perform LED checking and system functional test
- 10) Connect the unit to a chart plotter via NMEA0183 or NMEA2000 interface if applicable

4.2 Mounting the M10 Unit

The following guidelines should be noted when selecting the environment to install your McMurdo Smartfind M10:

- i Do not install the M10 AIS transponder in a flammable or hazardous atmosphere such as in an engine or generator room or close to fuel tanks.
- i Installation of the transponder should be undertaken in a safe environment without being exposed to any splashing from water or rain.
- i There should be adequate space around the AIS transponder for routing of cables. See figure below for details of the AIS transponder dimensions.
- i The safe distance of the transponder to any magnetic compass is at least 0.55m.
- i The operating temperature for the unit is between -15°C and +55°C.
- i The AIS transponder should be installed and mounted on a flat surface, or it can be mounted on a wall with the four self tapping screws supplied.
- i The device should be mounted in a location where the indicators can readily be observed as these indicators deliver relevant information on the status of the AIS transponder.

4.3 Installing the AIS Transponder

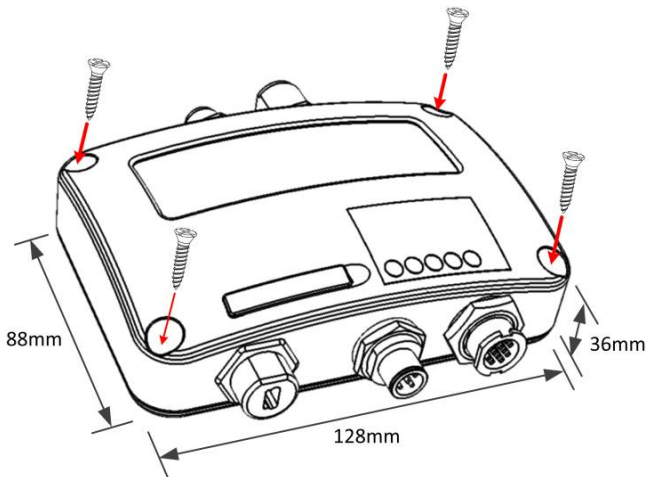

Figure 1 **Mounting the transponder**

4.4 VHF Antenna Installation

The quality and positioning of the antennas are the most important factors in dictating AIS performance. It is recommended that a VHF antenna with omnidirectional vertical polarization and specifically tuned for AIS operation band be used. Since the range of VHF signals is largely decided by line of sight distance, the VHF antenna should be placed as high as possible and at least 5 meters away from any constructions made of conductive materials. It is recommended to keep the VHF antenna at least 3 meters away from the GPS antenna.

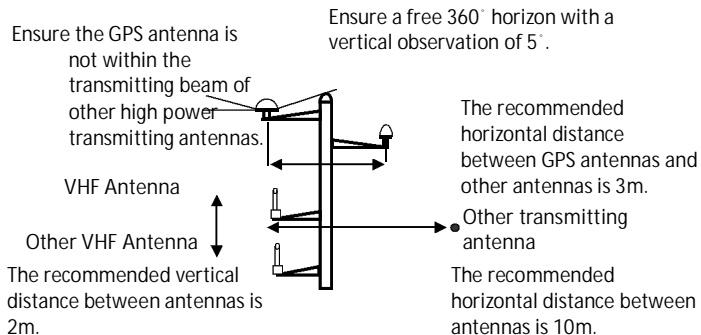

Figure 2 VHF/GPS antenna locations



WARNING: The safe distance from a transmitting VHF antenna is 60cm.

4.5 GPS Antenna Installation

The ANT-21 GPS antenna that is supplied with the unit, must be installed where it has a clear view of the sky, so that it may access the horizon freely with 360° degrees, with a vertical observation of 5 to 90 degrees above the horizon as illustrated in the figure above.

GPS Antenna Location

Enter the GPS antenna location data in the “SHIP SETTING” tab in the configuration utility after the installation has been completed. The GPS antenna location offsets required to be entered are as shown below:-

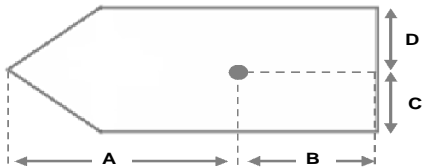

Figure 3 GPS antenna location

When connecting the GPS antenna cable, take note of the following precautions.

- i Sharp bending of the cable may cause damage to the inner wires and impair the overall performance.
- i The coaxial cable should be run separately to other cables.
- i Insulation tape on the GPS connector on the coaxial cable is recommended.

4.6 Connecting Power and Data Cable

The connections for the cable used on the Smartfind M10 are illustrated in the diagram below, these are for the connections to an external power source and data equipment

Wiring Definition

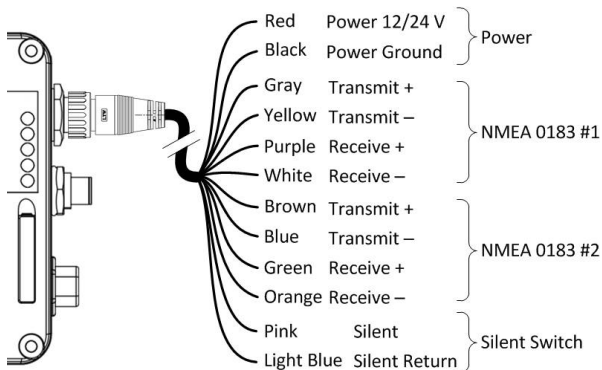

Figure 2 **Wiring instructions**

When wiring the M10 to a NMEA0183 AIS-ready equipment, please refer to your equipment manual first. The Smartfind M10 supports two NMEA0183 ports and each can be configured to 4800, 9600, or 38400 baud rate independently. The default baud rate for both ports is 38400. Use the provided M10 configuration utility to change baud rates.



Smartfind M10W supports only one baud rate configuration for both Tx & Rx on NMEA0183 port #2.

4.7 Connecting with NMEA0183 Devices

The Smartfind M10 supports two NMEA0183 ports and each of the NMEA0183 port's transmitting and receiving interfaces can be configured to 4800, 9600, or 38400 baud rate independently. The default baud rate for both ports is 38400-bps. The provided M10 configuration utility enables the user to change the baud rates. Typically the high speed setting is intended primarily for a chart plotter connection, while the lower speed setting can be used to connect it to other NMEA0183 devices. The ports have bidirectional multiplexing, which means any received messages via one port are automatically transmitted to the other port and vice-versa.

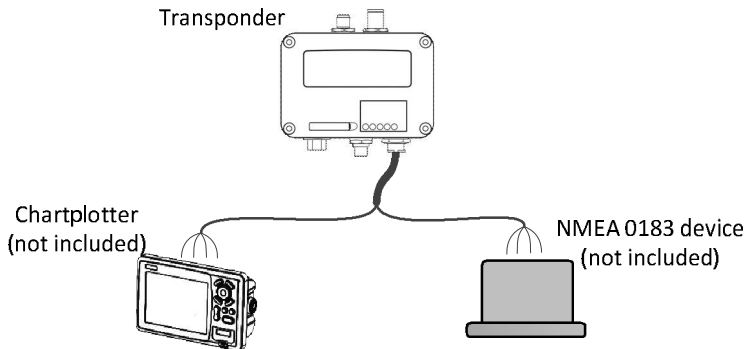
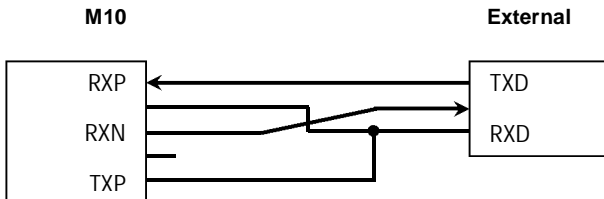

Figure 3 **Multiplexing with NMEA0183 ports**

In order to ensure an errorless operation, both NMEA0183 ports should be only connected with NMEA0183 devices. In case RS232 devices are required to be connected and no dedicated RS-422 to RS232 converter is available, the connection should be configured as shown in the figures below. Please note that the wiring is made at user's own risk, as such connection might cause damage to the transponder.



| Core Colour of M10 cable | Description (NMEA 0183 Signal) | Signal Direction (for M10) | External NMEA 0183 Device |
|--------------------------|--------------------------------|----------------------------|---------------------------|
| Brown | Data Input + (RXP) | Input | RS-232 Data Output |
| Blue | Data Input - (RXN) | - | RS-232 Ground |
| Yellow | Data Output + | Output | RS-232 Data |

| | | | |
|-------|--------------|---|---------------|
| | (TXP) | | Input |
| Black | Power Ground | - | RS-232 Ground |

Figure 1 NMEA0183 to RS232 Connection

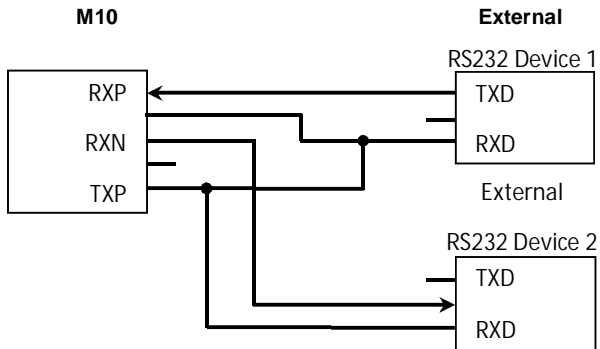

| Core Colour of M10 cable | Description (NMEA 0183 Signal) | Signal Direction (for M10) | External NMEA 0183 Devices |
|--------------------------|--------------------------------|----------------------------|-------------------------------|
| Brown | Data Input + (RXP) | Input | RS-232 Data Output @ Device 1 |
| Blue | Data Input - (RXN) | - | RS-232 Ground @ Device 1 |
| Black | Power Ground | - | RS-232 Ground @ Device 1 |
| Yellow | Data Output + (TXP) | Output | RS-232 Data Input @ Device 2 |
| Blue | Data Input - | - | RS-232 Ground @ |

| | | | |
|-------|--------------|---|-----------------------------|
| | (RXN) | | Device 2 |
| Black | Power Ground | - | RS-232 Ground @ Device 2 |

4.8 AIS TX Silent Mode

If you require to use the TX Silent Mode feature, you will need to connect an external toggle switch (not supplied) to the Smartfind M10.

To use this featured connect the toggle switch between the pink and light blue wires (Silent Switch connections) to enable the Silent Mode function. When the two wires are shorted together by the switch, the unit will be in Silent Mode and will not transmit and the Tx/Silent LED will be red.

4.9 Connecting to a Power Supply

The Smartfind M10 requires a 12V or 24V DC power supply (9.6 – 31.2V operation range) capable of supplying 2A peak current. The red wire and black wire on the 12 pin cable supplied are used to connect the power supply's positive and negative terminals. A 5 Amp fuse or circuit breaker must be used in the connection between the power supply and the unit.

4.10 Connection to NMEA2000 Network

NMEA2000 is the latest marine standard for data communication between marine instruments. With a NMEA 2000 network onboard, a faster data throughput, better transmission reliability and easy data sharing can be realized.

The Smartfind M10 is equipped with a NMEA2000 interface with a connection value of LEN=1. AIS targets received by the transponder will be displayed on your chart plotter when both are connected to a NMEA2000 network with a compatible T-connector and drop cable, available from your local service partner.

5 GET STARTED

5.1 Start up the Transponder

The transponder will start up whenever the connected power source is ON. It will operate automatically if the transponder has been properly configured using the Configuration Software (MMSI entered) and GPS/VHF antennas are also properly installed and connected to the unit. Normally the transponder should transmit its own ships position every 30 seconds or 3 minutes depending on the vessel speed. It should also receive other vessels' information that are in the vicinity.

The operational status of the transponder can be visually checked from the LED lights on the unit. Description of the LED indicators are provided in the following section.

5.2 LED Indicators

| Indicator | Light | Description |
|-------------------------|----------------------------|---|
| Power | Green | The green LED indicates that the transponder has been powered up correctly. |
| Error | Red | The red LED indicates that MMSI is not correctly set or the system has a BIIT error. Please refer to section 5.5 for more information about BIIT. |
| Rx | Green | The green LED flashes when the transponder is receiving AIS data. |
| Tx/Silent | Green/Red | The LED flashes green when the transponder is transmitting AIS data. When the device is set to silent mode, the LED is a steady red. |
| SD | Green (Flashing/ On) | Flashing: SD card is being accessed. On: SD card is full. Replace with empty SD card or delete files to obtain free space. Off: There is not a SD card connected. |
| Wi-Fi (M10W only) | Green | The green LED indicates there is Wi-Fi activity. |

5.3 SD Card Data Logging

The Smartfind M10 records voyage data onto a SD card in log files in a .txt format. The compatible SD card types supported by the M10 are listed as followed:

- i Standard “SD” with maximum 2GB size
- i Supported data format: FAT12/16

- i Standard “SDHC” with maximum 32GB size
- i Supported data format: FAT32

To ensure correct operation the SD card must be inserted before M10 is powered on. When a SD card is inserted, into the card slot as shown below and powered up the unit will start data logging. When the unit is data logging it is indicated by the flashing green SD LED indicator.

The log files naming convention is AIS_XXXXXX.txt, and each log file will be incremented from 000001 to 999999 (depending on memory size of SD card). The log file will also include the vessel's GPS sentence which will be in IEC61162 format.

When the SD card memory is full, the SD LED indicator will turn a steady green to remind user to replace the SD card. Once the SD card is full no further data logging will take place until the SD is replaced with an empty or a SD card that has available capacity.

Removing the SD card from the transponder stops data logging immediately, and the SD LED will turn off. Make sure the transponder's power is off before

inserting a SD card, if the card is inserted when the unit is on, the SD LED will be a steady green and no data logging will occur.

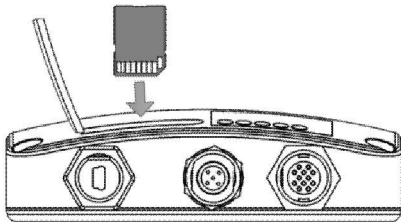

Figure 4 **Inserting SD memory card**

5.4 Wi-Fi Configuration (M10W only)

Installation of Wi-Fi antenna is straight forward. Screw on the antenna firmly to the WiFi connection and then adjust the antenna to be in a vertical position.

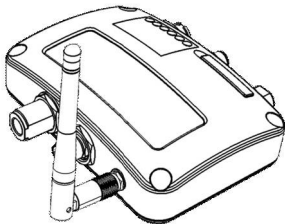

Figure 5 **Transponder with Wi-Fi antenna connected**

Refer to your devices manual to see how to connect to devices using a WiFi connection. The details below is the information for the M10W and may be needed to connect with your device.

■ **SSID (Service Set Identifier):**

The SSID for the M10W is **AIS-B-NNNN** where **NNNN** is the last 4 digits of the units serial number (printed on the label on the side of the unit)

■ **Security Encryption:**

- i Any device being used to connect to the M10W via WiFi should support WPA-PSK with TKIP data encryption
- i If requested by your device for an IP address or port number, use the following details
- i IP Address 192.168.2.1
- i Port 3333

- **Password:**
The M10W WiFi Network key is **123456789@**

The M10W SSID, security encryption and Network key (password) are non-configurable and pre-set at the factory.

5.5 Built-in Integrity Test (BIIT)

With a Built in Integrity Test (BIIT) function, the Smartfind M10 is constantly monitoring and testing the integrity of the AIS transponder. Should an abnormal condition be detected within the device, the Error LED will alert with a flashing red light. The following conditions will cause the Error LED to flash red

- i Antenna VSWR exceeding the maximum allowed level
- i MMSI not set
- i Background noise level exceeds allowable threshold (-77dBm)
- i GPS is unable to gain lock (3D fixed) after 30 minutes of losing GPS signal

5.6 AIS Viewer Description

The McMurdo AIS Viewer is a complementary software package which displays AIS targets on a PC screen, including outline mapping, and is supplied with your Smartfind M10 transponder. The software installation file for the McMurdo AIS Viewer can be found on the CD-ROM included with the M10 unit.

The McMurdo viewer allows users to display AIS targets either on a basic line map or in an alphanumeric view. It also allows your PC to be used as an AIS data logger (if the PC is running the viewer program and the data logging is enabled), which can be used to track other vessels with voyage track option and enables you to enter MMSI numbers for AIS Beacons to the MOB list. Once the program is installed, you can establish a connection between the M10 and the PC either automatically or manually by assigning the COM port and baud rate. Please note that before trying to connect to a PC, you should quit the Configuration Software or vice-versa. The transponder can only establish one connection to the AIS software at a time. The AIS viewer also allows the AIS CPA/TCPA setting to be configured via the AIS Viewer.

For further information regarding the AIS viewer refer to the User manual accessed via the viewer Help function.

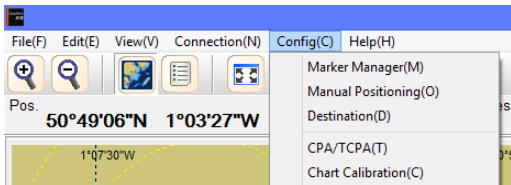

Figure 6 **McMurdo AIS Viewer**

6 SPECIFICATIONS

6.1 Product Specifications

| APPLICABLE STANDARDS | |
|-------------------------|---------------------------|
| IEC 62287-1 Ed. 2, 2010 | IEC 61108-1 Ed. 1, 2003 |
| IEC 61162-1 Ed. 3, 2007 | IEC 60945 Ed. 4, 2002 |
| IEC 61162-2 Ed. 1, 1998 | ITU-R M.1371-4, 2010 |
| VHF TRANSPONDER | |
| Frequency Range | 156.025 MHz ~ 162.025 MHz |
| Channel Bandwidth | 25 KHz |

| | |
|---------------------------|---|
| Modulation | GMSK / FM |
| Data Rate | 9,600 bps |
| Number of AIS Transmitter | 1 |
| Number of AIS Receiver | 2 (one time-shared between AIS and DSC) |
| Number of DSC Receiver | 1 (time-shared between AIS and DSC) |
| AIS Channel 1 | CH 87B (161.975 MHz) |
| AIS Channel 2 | CH 88B (162.025 MHz) |

| | |
|-----------------------------|--|
| Tx Power Output | 2 Watt (33 dBm \pm 1.5 dB) |
| Rx Sensitivity | < -107 dBm @ 20% PER |
| DSC RECEIVER | |
| Modulation | 1,300 Hz / 2,100 Hz FSK |
| Data Rate | 1,200 bps \pm 30 ppm |
| Spurious Response Rejection | \geq 70 dB for signal @ -104 dBm; BER \leq 1 % |
| Blocking | \geq 84 dB for signal @ -104 dBm; BER \leq 1 % |

GPS RECEIVER (integrated)

Receiving Channels

50 channels

Accuracy

IEC 61108-1 compliant

Output Rate

1 Hz

POWER SUPPLY

Supply Voltage

12V / 24V DC, 2A

Power Consumption

Typically less than 3W average @ 12V
DC

Smartfind M10

| | |
|-------------------------------------|---|
| Power Consumption Smartfind M10W | Typically less than 4W average @ 12V DC |
| CONNECTION INTERFACE | |
| GPS Antenna Connector | TNC (Female) |
| VHF Antenna Connector | PL-259 (Female) |
| NMEA2000 | Standard connector LEN=1 |
| NMEA 0183 (RS-422) | Supports two NMEA0183 interfaces Baud rate configurable (default 38,400 bps) Separate Tx/Rx baud rate Standard IEC 61162-1 / IEC 61162-2 sentences |

| | |
|---------------------------|---|
| Silent Mode Setting | Set by connecting the dedicated wires in the 12-pin cable together. |
| USB | Mini-B type, waterproof |
| Wireless Connection | IEEE 802.11 b/g/n (Smartfind M10W only) |
| ANT-21 GPS Antenna | |
| Cable Length | 10m |
| Mounting Bracket | Included |
| Supply Voltage | 3.3V |

ENVIRONMENTAL

Operating Conditions

IEC 60945 “protected” category

Operating Temperature

-15°C ~ +55°C

Waterproof

IPX2

PHYSICAL

Width

128 mm (5.51 inch)

Height

36 mm (1.97 inch)

Depth

88 mm (7.87 inch) (excluding
connectors)

| | |
|-----------------------------------|--------------------------|
| Weight | 250 g |
| SOFTWARE TOOL | |
| McMurdo AIS Class B Configuration | PC configuration utility |
| McMurdo AIS Viewer | AIS Viewer for PC |

6.2 Dimensions

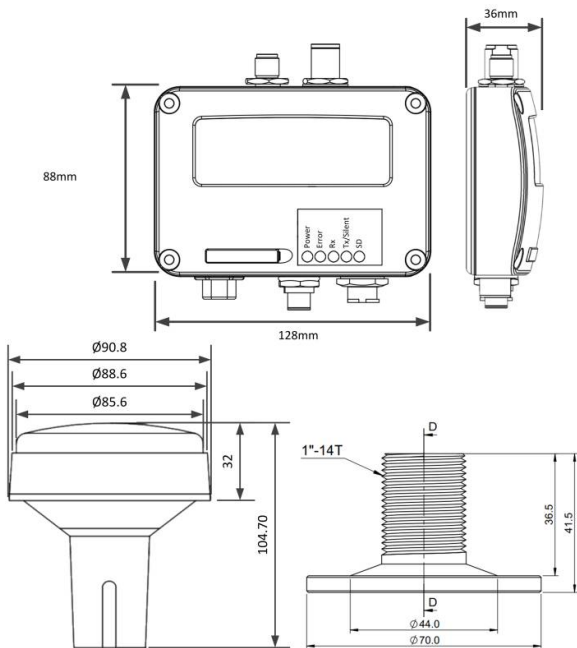

6.3 NMEA 2000 PGN Information

The following table is a list of the NMEA 2000 messages supported by the Smartfind M10 unit.

The “Transmit” PGNs information includes “Own ship” + “Received AIS information from other ships” and is the reason the NMEA2000 PGN list covers both Class A and Class B related information.

| Transmit | |
|----------|--|
| PGN | Description |
| 59392 | ISO Acknowledgment |
| 59904 | ISO Request |
| 60928 | ISO Address Claim |
| 126464 | PGN List - Transmit PGN's group function |
| 126996 | Product Information |
| 129038 | AIS Class A Position Report |
| 129039 | AIS Class B Position Report |
| 129040 | AIS Class B Extended Position Report |
| 129041 | AIS Aids to Navigation (AtoN) Report |
| 129792 | AIS DGNSS Broadcast Binary Message |
| 129793 | AIS UTC and Date Report |

| 129794 | AIS Class A Static and Voyage Related Data |
|----------------|---|
| 129795 | AIS Addressed Binary Message |
| 129796 | AIS Acknowledge |
| 129797 | AIS Binary Broadcast Message |
| 129800 | AIS UTC/Date Inquiry |
| 129801 | AIS Addressed Safety Related Message |
| 129802 | AIS Safety Related Broadcast Message |
| 129803 | AIS Interrogation |
| 129804 | AIS Assignment Mode Command |
| 129805 | AIS Data Link Management Message |
| 129806 | AIS Class A Position Report |
| 129807 | AIS Group Assignment |
| 129808 | DSC Call Information |
| 129809 | AIS Class B "CS" Static Data Report, Part A |
| 129810 | AIS Class B "CS" Static Data Report, Part B |
| Receive | |
| PGN | Description |
| 59392 | ISO Acknowledgment |
| 59904 | ISO Request |
| 60928 | ISO Address Claim |

7 TROUBLESHOOTING

The transmitting LED (Green colour) is not illuminated

The transmitting interval of a Class B transponder is 3 minutes if the speed of the vessel is less than 2 knots. If the speed exceeds 2 knots, the transmitting interval will be 30 seconds. For each transmission, the Tx/Silent LED will flash Green once quickly. The Tx indication could be missed if not observed carefully.

- i For unit to transmit it requires the GPS information from the GPS antenna. Without the GPS information, the unit will not transmit an AIS signal. Please check if your GPS antenna is connected and setup correctly.

Smartfind M10 receives AIS signals normally, but no one in the surrounding can see me, why?

- i AIS Class B transmission range limitation: an AIS Class B transponder transmitting range is 5-7 miles in perfect conditions. The AIS receiver in the transponder will typically see Class A vessels that are 20-30 miles away or more in good conditions. The reason for this is that all AIS Class B transmit at 2 watts whereas the Class A transmit at 12.5. This difference in transmission power impacts on the range of each transponder type. For this reason, it is quite possible that Class A vessels can be seen, but Class B vessels might not be seen.

- i VHF antenna interference: if you are using a dedicated AIS/VHF antenna for your transponder, be sure that it is placed at least 6 ft (1.83 m) away from other VHF antennas or vertical metal objects and ideally install the antenna on a different vertical plane from other VHF antennas. In several tests, mounting two VHF antennas next to each other typically reduces the transmitting range to both antennas by 50-70%.
- i GPS is not fixed: If your GPS antenna is not connected or setup correctly, your transponder will see other vessels fine, but you will not be sending out your vessel position. All AIS transponders need a good GPS fix before it can send out any type of transmission. The colour and state of the LEDs on the transponder indicate if the unit is in transmission mode or not.
- i The location of the VHF antenna is directly related to AIS transmitting range. The VHF antenna should be installed as high as possible.

The silent mode (Tx off) on Smartfind M10 is not working.

- i Silent mode can be configured on Smartfind M10 by connecting the Silent Switch wires in the cable together.

Even though my Smartfind M10 is transmitting, why do some vessels with AIS take a long time to see my vessel name or not see it at all?

- i AIS Class B users should keep in mind that Class B transponders do not broadcast position updates as often as Class A commercial transponders. The full static information (such as vessel's name) transmission is

broadcasted every 6 minutes; however, the MMSI and dynamic information, (position update) will be sent out every 3 minutes if the vessel is moving slower than 2 knots or every 30 seconds in moving faster than 2 knots. In addition to this, if the receiving party is using a non-standard dual channel receiver or a single channel receiver, then in ideal conditions, the receiver will get your full static information every 12 minutes and your MMSI and dynamic information every 6 minutes if you are moving slower than 2 knots.

No data is being received by chart plotter

- i Please check that the power supply is connected correctly to the Smartfind M10.
- i Please check that the power supply is 12V or 24V with sufficient current capacity (no less than 2A).
- i Please make sure that the connections between the Smartfind M10 and the chart plotter are correct.

My MMSI is being received by other vessels but my vessel name is not shown on their chart plotter or PC

- i Older chart plotter software and AIS displays may not be fully compatible with Class B transponders. In some cases, older equipment might only have Class B vessel show up on their displays with just an MMSI number without the vessel name. This is usually due to the displaying device not knowing how to process the Message 24 static data from Class B

transponders. Please contact the chart plotter manufacturer and ask for software upgrades (for these older chart plotters) to resolve this issue.

The Red Error LED indication on the Smartfind M10 is illuminated.

- i The unit may not have a valid MMSI. Please check if the AIS transponder is correctly entered with a valid MMSI.
- i Please make sure that both VHF and GPS antennas and their cables are working properly and not damaged.

If you still encounter difficulties with the set up or operation of the Smartfind M10, please email service.mcmurdo@orolia.com with your details, the device information and the issue you are having.

8 ABBREVIATIONS

| | |
|--------|--|
| AIS | Automatic Identification System |
| COG | Course Over Ground |
| CPA | Distance to Closest Point of Approach |
| CSTDMA | Carrier-Sense Time Division Multiple Access |
| DSC | Digital Selective Calling |
| ECS | Electronic Chart System |
| ETA | Estimated Time of Arrival |
| GPS | Global Positioning System |
| IMO | International Maritime Organization |
| MMSI | Maritime Mobile Service Identity |
| SOG | Speed Over Ground |
| TCPA | Time to Closest Point of Approach |
| TDMA | Time Division Multiple Access |
| UTC | Coordinated Universal Time |
| VHF | Very High Frequency |
| VTS | Vessel Traffic Services |

9 AIS Information

9.1 Class A vs. Class B AIS

A brief comparison of class A and class B AIS is illustrated in the following table.
The Smartfind M10 is a class B AIS transponder.

Table 1-1 Comparison of Class A and Class B

| Type of AIS | Class A AIS | Class B AIS |
|-----------------------------|---|---|
| Communication Protocol | SOTDMA (Self-organizing) | CSTDMA (Carrier-Sense) |
| Transmit Power and range | 12.5w (25 NM expected) | 2w (5-7 NM expected) |
| IMO Mandate | Mandatory for all SOLAS compliant vessels | No mandate |
| Reporting rate dynamic data | Higher (transmission up to every 2 sec) | Lower (transmission up to every 30 sec) |

| | | |
|--------------------|--|--|
| AIS data presented | Static, Dynamic, Voyage | Static and Dynamic data |
| Applications | Commercial vessels, fishing boats, working boats, passenger boats with more than 12 passengers | Recreational vessels and small fishing boats |

10 Orolia Ltd WORLDWIDE WARRANTY

Limited warranty

IMPORTANT Orolia Limited warranty registration

Congratulations on purchasing your Smartfind M10. As standard your unit has a one year (12 months) warranty from the date of purchase shown on your invoice, however, this can be extended by an additional year by simply registering your unit on-line at:

www.mcmurdomarine.com

Then follow the REGISTER WARRANTY link at the top of the page.

Warranty Statement

Subject to the provisions set out below Orolia Ltd warrants that this product will be free of defects in materials and workmanship for a period of up to two years (subject to registration, see above) from the

date of purchase. Orolia Ltd will not be liable to the buyer under the above warranty:-

for any defect arising from fair wear and tear, wilful damage, negligence, abnormal working conditions, water damage or use of solvents, failure to follow Orolia Ltd's instructions (whether oral or in writing) including a failure to install properly and/or to use materials recommended and/or supplied by Orolia Ltd, misuse or alterations or repair of the product by persons other than Orolia Ltd or an Orolia approved Service Agent;

for parts, materials or equipment not manufactured by Orolia Ltd in respect of which the buyer shall only be entitled to the benefit of any warranty or guarantee given by the manufacturer to Orolia Ltd;

If the total price for the product has not been paid.

THE LIMITED WARRANTY STATED ABOVE IS EXCLUSIVE AND IN LIEU OF ANY OTHER WARRANTY, EXPRESS OR IMPLIED, INCLUDING BUT NOT LIMITED TO ANY IMPLIED WARRANTY OF MERCHANTABILITY OR FITNESS FOR A PARTICULAR PURPOSE. Orolia Ltd will not be liable for indirect, special, incidental or consequential damages of any kind sustained from any cause. In no event shall Orolia Ltd be liable for any breach of warranty or other claim

in an amount exceeding the purchase price of the product. This warranty does not affect any statutory rights of the consumer. In order to be valid, claims must be made under the above warranty in writing as soon as practicable after discovery of the defect or failure and within the warranty period referred to above. Proof of purchase will be required. The claim should be sent together with the product in question to the address set out below or to an Approved Service Agent. Following a valid warranty claim Orolia Ltd shall be entitled to repair or replace the product (or part) in question free of charge, or at Orolia Ltd's sole discretion to refund to the buyer the price of the product (or a proportional part of the price). Orolia Ltd shall not be liable to a buyer who is not a consumer for any other loss or damage (whether indirect, special or consequential loss of profit or otherwise) costs, expenses or other claims for compensation which arise out of or in connection with this product. In the case of a consumer Orolia Ltd shall only be liable where other loss or damage is foreseeable.

Nothing shall limit Orolia Ltd's liability for death or personal injury caused by its negligence. This warranty is to be interpreted under English law.

All enquiries relating to this warranty or Approved Service Agents should be sent to:

Orolia Limited,
Silver Point,
Airport Service Road,
Portsmouth,
Hampshire,
PO3 5PB,
UK

Telephone: Int + 44 (0) 23 9262 3900

Fax: Int + 44 (0) 23 9262 3998

Web: www.mcmurdomarine.com

Email: service.mcmurdo@orolia.com

An Orolia Group Business

21-235-001 Issue 1