

SPLIT TYPE ROOM AIR CONDITIONER INSTALLATION MANUAL

(PART No. 9314963032-01)

(Z24LB)

This air conditioner uses new refrigerant HFC (R410A).

The basic installation work procedures are the same as conventional refrigerant (R22) models. However, pay careful attention to the following points:

- Since the working pressure is 1.6 times higher than that of conventional refrigerant(R22) models, some of the piping and installation and service tools are special.(See the table below.) Especially, when replacing a conventional refrigerant(R22) model with a new refrigerant R410A model, always replace the conventional piping and flare nuts with the R410A piping and flare nuts.
- Models that use refrigerant R410A have a different charging port thread diameter to prevent erroneous charging with conventional refrigerant(R22) and for safety. Therefore, check beforehand.[The charging port thread diameter for R410A is 1/2 threads per inch.]
- Be more careful that foreign matter (oil, water, etc.) does not enter the piping than with refrigerant(R22) models. Also, when storing the piping, securely seal the opening by pinching, taping, etc.
- When charging the refrigerant, take into account the slight change in the composition of the gas and liquid phases, and always charge from the liquid phase side whose composition is stable.

Special tools for R410A

Tool name	Contents of change
Gauge manifold	Pressure is high and cannot be measured with a conventional gauge. To prevent erroneous mixing of other refrigerants, the diameter of each port has been changed. It is recommended the gauge with seals-0.1 to 5.3 MPa (-1 to 53 bar) for high pressure. -0.1 to 3.8 MPa (-1 to 38 bar) for low pressure.
Charge hose	To increase pressure resistance, the hose material and base size were changed.
Vacuum pump	A conventional vacuum pump can be used by installing a vacuum pump adapter.
Gas leakage detector	Special gas leakage detector for HFC refrigerant R410A.

Copper pipes

It is necessary to use seamless copper pipes and it is desirable that the amount of residual oil is less than 40 mg/10m. Do not use copper pipes having a collapsed, deformed or discolored portion (especially on the interior surface). Otherwise, the expansion valve or capillary tube may become blocked with contaminants.

As an air conditioner using R410A incurs pressure higher than when using R22, it is necessary to choose adequate materials. Thicknesses of copper pipes used with R410A are as shown in Table1.Never use copper pipes thinner than that in the table when it is available on the market.

Table 1 Thicknesses of Annealed Copper Pipes

		Thickness (mm)
Nominal diameter	Outer diameter (mm)	R410A
1/4	6.35	0.80
5/8	15.88	1.0

WARNING

- Do not use the existing (for R22) piping and flare nuts.
 - If the existing materials are used, the pressure inside the refrigerant cycle will rise and cause breakage, injury, etc.(Use the special R410A materials.)
- When installing and relocating the air conditioner, do not mix gases other than the specified refrigerant(R410A) to enter the refrigerant cycle.
 - If air or other gas enters the refrigerant cycle, the pressure inside the cycle will rise to an abnormally high value and cause breakage, injury, etc.

CAUTION

When installing pipes shorter than 3m, sound of the outdoor unit will be transferred to the indoor unit, which will cause large operating sound or some abnormal sound.

For authorized service personnel only.

WARNING

- For the room air conditioner to operate satisfactory, install it as outlined in this installation manual.
- Connect the indoor unit and outdoor unit with the air conditioner piping and cords available standards parts. This installation manual describes the correct connections using the standard accessories and the parts specified in this installation manual.
- Have installation work done by authorized service personnel only.
- Also do not use an extension cord.
- Do not turn on the power until all installation work is complete.
- When connecting pipes, be sure to install the JOINT PIPE included on the indoor unit.
- When connecting outdoor units, do not alter the pipe diameter from 15.88 mm to 12.7 mm.

- Be careful not to scratch the air conditioner when handling it.
- After installation, explain correct operation to the customer, using the operating manual.
- Let the customer keep this installation manual because it is used when the air conditioner is serviced or moved.
- The maximum length of the piping is 30 m. The maximum height difference of the piping is 20 m, if the units are further apart than these, correct operation can not be guaranteed.

STANDARD ACCESSORIES

The following installation accessories are supplied. Use them as required.

Name and Shape	Q'ty	Name and Shape	Q'ty
Wall hook bracket	1	Drain pipe	1
		Cloth tape	1
Remote control unit	1	Tapping screw(big)	8
		Tapping screw(small)	2
Battery	2	Seal A	1
		Insulation (seal)	1
Remote control unit holder	1	Joint pipe #Length: 600 mm	1

One set of following parts are necessary in installation of this product.

Name
Connection pipe assembly
Connection cord
Wall pipe
Decorative tape
Vinyl tape
Wall cap
Saddle
Drain hose
Tapping screws
Sealant

ELECTRICAL REQUIREMENT

Electric wire size and fuse capacity:

Power supply cord (mm ²)	MAX.	4.0
	MIN.	3.5
Connection cord (mm ²)	MAX.	2.5
	MIN.	1.5
Fuse capacity (A)		30

- Install the disconnect device with a contact gap of at least 3mm nearby the units. (Both indoor unit and outdoor unit)
- Always make the air conditioner power supply a special branch circuit and provide a special breaker.
- Always use Type245 IEC57 or equivalent as the power supply cord and the connection cord.

SELECTING THE MOUNTING POSITION

Decide the mounting position with the customer as follows:

1. INDOOR UNIT

- Install the indoor unit level on a strong wall which is not subject to vibration.
- The inlet and outlet ports should not be obstructed: the air should be able to blow all over the room.
- Do not install the unit near an electric outlet or special branch circuit.
- Do not install the unit where it will be exposed to direct sunlight.
- Install the unit where connection to the outdoor unit is easy.
- Install the unit where the drain pipe can be easily installed.
- Take servicing, etc. into consideration and leave the spaces shown in (Fig. 2). Also install the unit where the dustbox and the filter can be removed.

2. OUTDOOR UNIT

- If possible, do not install the unit where it will be exposed to direct sunlight. If necessary, install a blind that does not interfere with the air flow.
- Do not install the unit where a strong wind blows or where it is very dusty.
- Do not install the unit where people pass.
- Take your neighbors into consideration so that they are not disturbed by air blowing into their windows or by noise.
- Provide the space shown in Fig. 2 so that the air flow is not blocked. Also for efficient operation, leave open three of the four directions front, rear, and both sides.

WARNING

Install at a place that can withstand the weight of the indoor and outdoor units and install positively so that the units will not topple or fall.

CAUTION

- Do not install where there is the danger of combustible gas leakage.
- Do not install near heat sources.
- If children under 10 years old may approach the unit, take preventive measures so that they cannot reach the unit.
- Install the indoor unit on the wall where the height from the floors more than 230 cm.

INSTALLATION DIAGRAM OF INDOOR AND OUTDOOR UNITS

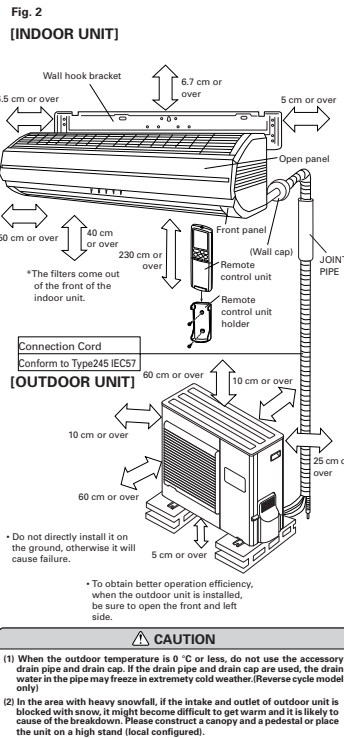

(Indoor unit piping direction)

The piping can be connected in the six directions indicated by ①, ②, ③, ④, ⑤ and ⑥ in (Fig. 1). When the piping is connected in direction ① or ②, cut along the piping groove in the side of the front panel with a hacksaw. When connecting the piping in direction ③ or ④, cut a notch in the thin wall at the front bottom of the front panel.

Fig. 1

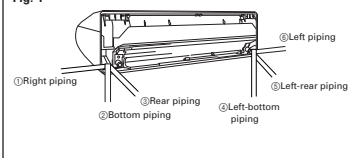

FRONT PANEL REMOVAL AND INSTALLATION

REMOVING THE FRONT PANEL

- Open the open panel, and then remove the top cover and dust box. (For the removal method of dust box, please refer to the OPERATING MANUAL or Dust Box)
- Remove the top grille. (For the removal method of top grille, please refer to the OPERATING MANUAL)
- Remove the screw cap, and then remove the fixed screws (3 places).
- Press the under cover with hand at [▽] mark and pull out, and remove inside hooks (2 places) from the wall hook bracket.
- Remove the top hooks of under cover (2 places at left and right).
- Remove the front fixed screws (7 places).
- Push the lower side of front panel to outside, and remove the lower hooks from the body.
- After pull out the upper hooks inside the front panel (2 places at right side and left upper body, 1 place in the center upper body), pull them back, and remove the front panel.

INSTALLING THE FRONT PANEL

- Cover the front panel onto the body from the front side, and mount the upper, central and lower hooks.
- Install the front fixed screws (2 places at left and right side above the body, 1 place in the center of the body, 2 places under the body, 2 places in the center, altogether 7 places).
- Install the top hooks of under cover (2 places at left and right).
- Install the inside hooks (2 places) and front hooks (2 places) of under cover.
- Install fixed screws (3 places) and screw cap.
- Install the top grille.
- Fix with screws, install top cover and dust box.

CAUTION

- Be sure to remove the top grille at the position where the front panel is installed and removed.
- Be careful that the top grille may fall and cause personal injury.

CAUTION

Install the open panel and top grille securely. If installation is imperfect, the open panel or top grille may fall off and cause injury.

CUSTOMER GUIDANCE

Explain the following to the customer in accordance with the operating manual:

- Starting and stopping method, operation switching, temperature adjustment, timer, air flow switching, and other remote control unit operations.
- Dustbox, air filter and top grill removal and cleaning, and how to use the air louvers.
- Give the operating and installation manuals to the customer.

Fig. 4

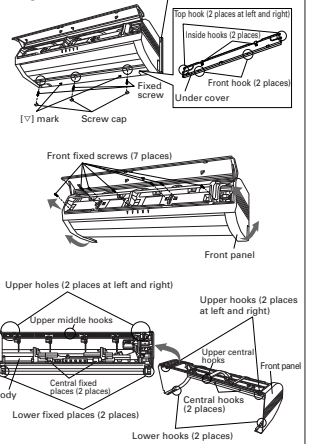

PUMP DOWN OPERATION (FORCED COOLING OPERATION)

To avoid discharging refrigerant into the atmosphere at the time of relocation or disposal, recover refrigerant by doing the cooling operation or forced cooling operation according to the following procedure. (When the cooling operation cannot start in winter, and so on, start the forced cooling operation.)

- Do the air purging of the charge hose by connecting the charging hose of gauge manifold to the charging port of 3 way valve and opening the low-pressure valve slightly.
- Close the valve stem of 2 way valve completely.
- Start the cooling operation or following forced cooling operation.
 - When using the remote control unit: Press the TEST RUN button after starting the cooling operation by the remote control unit. The operation indicator lamp and timer indicator lamp will begin to flash simultaneously during test run. When using the MANUAL AUTO button of the indoor unit (The remote control unit is lost, and so on.) Keep on pressing the MANUAL AUTO button of the indoor unit for more than 10 seconds. (The forced cooling operation cannot start if the MANUAL AUTO button is not kept on pressing for more than 10 seconds.)
 - Close the valve stem of 3 way valve when the reading on the compound pressure gage becomes 0.05-0 Mpa (0.5-0 kg/cm²).
 - Stop the operation.
 - Press the START/STOP button of the remote control unit to stop the operation.
 - Press the MANUAL AUTO button when stopping the operation from indoor unit side. (It is not necessary to press on keeping for more than 10 seconds.)

CAUTION

- During the pump down operation, make sure that the compressor is turned off before you remove the refrigerant piping.
- Do not remove the connection pipe while the compressor is in operation with 2 way or 3 way valve open. This may cause abnormal pressure in the refrigeration cycle that leads to breakage and even injury.

POWER

WARNING

- The rated voltage of this product is 230 V AC 50 Hz.
- Before turning on the power, check if the voltage is within the 220 V -10 % to 240 V +10 % range.
- Always use a special branch circuit and install a special receptacle to supply power to the room air conditioner.
- Use a circuit breaker and receptacle matched to the capacity of the air conditioner.
- Do not extend the power cord.
- Perform wiring work in accordance with standards so that the air conditioner can be operated safely and positively.
- Install a leakage circuit breaker in accordance with the related laws and regulations and electric company standards.

CAUTION

- The power source capacity must be the sum of the air conditioner current and the current of other electrical appliances. When the current contracted capacity is insufficient, change the contracted capacity.
- When the voltage is low and the air conditioner is difficult to start, contact the power company the voltage raised.

INDOOR UNIT

CUTTING THE HOLE IN THE WALL FOR THE CONNECTING PIPING

CAUTION

Drill the hole on wall with diameter shown in the table below.

INDOOR UNIT PIPING DIRECTION (Fig.1)	Diameter of hole in the wall
①②③④	φ80
⑤	φ65

When taking out pipe from rear (Fig.1) or left rear (Fig.1), if the hole diameter has been set φ80 mm, the wall cap will interfere with air conditioner and mounting plate.

- When cutting the wall hole at the inside of the wall hook bracket, cut the hole within the range of the left and right center marks 40 mm below the wall hook bracket. When cutting the wall hole at the outside of the wall hook bracket, cut the hole at least 10 mm below over.
- Cut the hole so that the outside end is lower (5 to 10 mm) than the inside end.
- Always align the center of the wall hole. If misaligned, water leakage will occur.
- Cut the wall pipe to match the wall thickness, stick it into the wall cap, fasten the cap with vinyl tape, and stick the pipe through the hole. (The connection pipe is supplied in the installation set.) (Fig. 5)
- For left piping and right piping, cut the hole a little lower so that drain water will flow freely. (Fig. 5)

Fig. 5

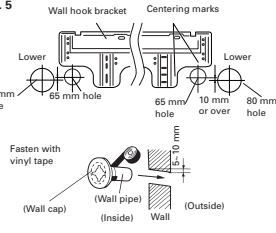

INSTALLING THE WALL HOOK BRACKET

- Install the wall hook bracket so that it is correctly positioned horizontally and vertically. If the wall hook bracket is tilted, water will drip to the floor.
- Install the wall hook bracket so that it is strong enough to withstand the weight of an adult.
- Fasten the wall hook bracket to the wall with 8 or more screws through the holes near the outer edge of the bracket.
- Check that there is no rattle at the wall hook bracket.

Fig. 6

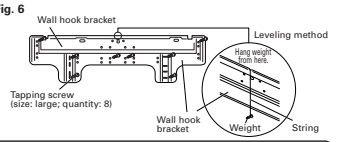

WARNING
If the wall pipe is not used, the cord interconnecting the indoor and outdoor units may touch metal and cause electric leakage.

CAUTION

Install the wall hook bracket horizontally and perpendicularly.

FORMING THE DRAIN HOSE AND PIPE

Rear piping, Right piping, Bottom piping

- Install the indoor unit piping in the direction of the wall hole and bind the drain hose and pipe together with vinyl tape. (Fig. 7)
- Install the piping so that the drain hose is at the bottom.
- Wrap the pipes of the indoor unit that are visible from the outside with decorative tape.

[For Left rear piping, Left piping]

Interchange the drain cap and the drain hose.

CAUTION

- In order to align the drain hose and drain cap, be sure to insert securely and vertically. Incline insertion will cause water leakage.
- When inserting, be sure not to attach any material besides water. If any other material is attached, it will cause deterioration and water leakage.
- After removing drain hose, be sure not to forget mounting drain cap.
- Be sure to fix the drain hose with tape to the bottom of piping.
- Prevent drain water frozen under low temperature environment.
When installing indoor unit's drain hose outdoors, necessary measure for frost protection should be taken to prevent drain water frozen.
Under low temperature environment (when outdoor temperature under 0 °C), after cooling operation is executed, water in the drain hose could be frozen.
Once drain water is frozen, the drain hose will be blocked and water leakage may be resulted for indoor unit.

- Be sure to install around the drain hose connector.
- As the screw is inside, be sure to use screwdriver treated with magnet.

Fig. 7

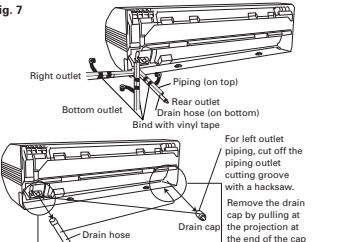

Removal method of drain hose

- Remove the screw at the left of drain hose and pull out drain hose.

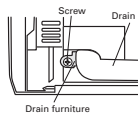

Installation method of drain hose

- Vertically insert the drain hose till the drain furniture aligns with the screw hole of drain cock. After inserting and before replacing, please reinstall and fix the removed screws.

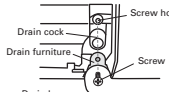

- For left piping and left rear piping, align the marks on the wall hook bracket and shape the connection pipe.
- Bend the Joint pipe at the bend radius of 70 mm or more and install no more than 35 mm from the wall.
- After passing the indoor piping and drain hose through the wall hole, hang the indoor unit on the hooks at the top and bottom of the wall hook bracket.

[Installing the indoor unit]

- Hang the indoor unit from the hooks at the top of the wall hook bracket.
- Insert the spacer, etc. between the indoor unit and the wall hook bracket and separate the bottom of the indoor unit from the wall.

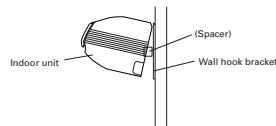
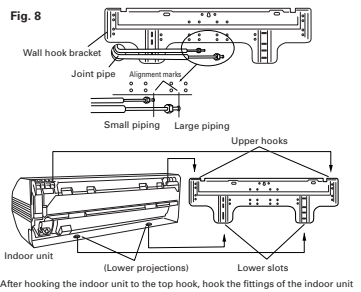

Fig. 8



After hooking the indoor unit to the top hook, hook the fittings of the indoor unit to the two bottom hooks while lowering the unit and pushing it against the wall.

CONNECTING THE PIPING

- Install the outdoor unit wall cap (supplied with the optional installation set or procured at the site) to the wall pipe.
- Connect the outdoor unit and indoor unit piping.
- After matching the center of the flare surface and tightening the nut hand tight, tighten the nut to the specified tightening torque with a torque wrench. (Table 2)

FLARING

- Cut the connection pipe to the necessary length with a pipe cutter.
 - Hold the pipe downward so that cuttings will not enter the pipe and remove the burrs.
 - Insert the flare nut onto the pipe and flare the pipe with a flaring tool.
- Check if (L) is flared uniformly and is not cracked or scratched.
- Insert the flare nut (always use the flare nut attached to the indoor and outdoor units respectively) onto the pipe and perform the flare processing with a flare tool.
- When using the conventional flare tool, always use an allowance adjustment gauge and secure the A dimension shown in table 3.

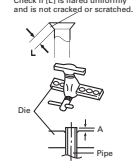

Fig. 9

- Tighten with two wrenches.
- To prevent gas leakage, coat the flare surface with refrigerant oil.

Table 2 Flare nut tightening torque

Flare nut	Tightening torque	L dimension
6.35 mm dia.	15.7 to 17.6 N·m (160 to 180 kgf·cm)	1.4 to 1.7 mm
12.7 mm dia.	49.0 to 52.9 N·m (500 to 550 kgf·cm)	1.9 to 2.2 mm
15.88 mm dia.	70.0 to 75.0 N·m (830 to 750 kgf·cm)	2.2 to 2.4 mm

Table 3 Pipe outside diameter

Pipe outside diameter	A (mm)		
	Flash tool for R410A clutch type	Conventional (R22) flare tool Clutch type	Wing nut type
φ 6.35 mm (1/4")	0 to 0.5	1.0 to 1.5	1.5 to 2.0
φ 12.7 mm (1/2")	0 to 0.5	1.0 to 1.5	1.5 to 2.0
φ 15.88 mm (5/8")	0 to 0.5	1.0 to 1.5	1.5 to 2.0

CAUTION

- Fasten a flare nut with a torque wrench as instructed in this manual. If fastened too tight, the flare nut may be broken after a long period of time and cause a leakage of refrigerant.
- During installation, make sure that the refrigerant pipe is attached firmly before you run the compressor. Do not operate the compressor under the condition of refrigerant piping not attached properly with 2-way or 3-way valve open. This may cause abnormal pressure in the refrigeration cycle that leads to breakage and even injury.

INDOOR UNIT WIRING

- Open the open panel.
- Hold the top cover.
- Remove the cord clamp.
- Route the connection cord from behind the indoor unit.
- Connect the end of the connection cord securely to the terminal block.
- Secure the connection cord with the cord clamp.
- Install the top cover with the screw.
- Close the open panel.

Fig. 10

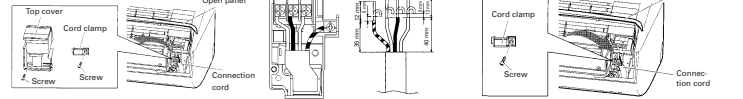

CAUTION

- Match the terminal block numbers and connection cord colors with those of the outdoor unit. Erroneous wiring may cause burning of the electric parts.
- Connect the connection cords firmly to the terminal block. Imperfect installation may cause a fire.
- Always fasten the outside covering of the connection cord with the cord clamp. (If the insulator is chafed, electric leakage may occur.)
- Securely earth the power cord plug.
- Do not use the earth screw for an external connector. Only use for interconnection between two units.

OUTDOOR UNIT

OUTDOOR UNIT INSTALLATION

WARNING

- Install the unit where it will not be tilted by more than 3°. However, do not install the unit with it tilted towards the side containing the compressor.
- When installing the outdoor unit where it may be exposed to strong wind, fasten it securely.

- Outdoor unit to be fasten with bolts at the four places indicated by the arrows without fail.

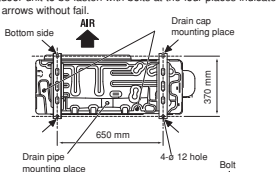

- Fix securely with bolts on a solid block. (Use 4 sets of commercially available M10 bolt, nut and washer.)

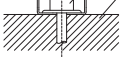

- Since the drain water flows out of the outdoor unit during heating operation, install the drain pipe and connect it to a commercial 16 mm hose. (Reverse cycle model only)
- When installing the drain pipe, plug all the holes other than the drain pipe mounting hole in the bottom of the outdoor unit with putty so there is no water leakage. (Reverse cycle model only)

CAUTION

When the outdoor temperature is 0 °C or less, do not use the accessory drain pipe and drain cap. If the drain pipe and drain cap are used, the drain water in the pipe may freeze in extremely cold weather. (Reverse cycle model only)

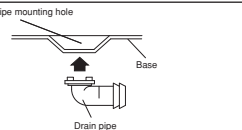

AIR PURGE

- Remove the cap, and connect the gauge manifold and the vacuum pump to the charging valve by the service hoses.
- Vacuum the indoor unit and the connecting pipes until the pressure gauge indicates -0.1 MPa (-76 cmHg).
- When -0.1 MPa (-76 cmHg) is reached, operate the vacuum pump for at least 60 minutes.
- Disconnect the service hoses and fit the cap to the charging valve to the specified torque.
- Remove the blank caps, and fully open the spindles of the 2-way valves and the 3-way valves with a hexagon wrench [Torque: 6-7 N·m (60 to 70 kgf·cm)].
- Tighten the blank caps of the 2-way valve and the 3-way valve to the specified torque.

CAUTION

- Do not purge the air with refrigerants, but use a vacuum pump to vacuum the installation! There is no extra refrigerant in the outdoor unit for air purging!
- Use a vacuum pump and gauge manifold and charging hose for R410A exclusively. Using the same vacuum for different refrigerants may damage the vacuum pump or the unit.
- After connecting the piping, check the all joints for gas leakage with gas leak detector.
- When adding refrigerant, add the refrigerant from the charging port at the completion of work.
- The maximum length of the piping is 30 m. If the units are further apart than this, correct operation can not be guaranteed.

Additional charge

Refrigerant suitable for a piping length of 15 m is charged in the outdoor unit at the factory. When the piping is longer than 15 m, additional charging is necessary. For the additional amount, see the table below.

Pipe length	15 m	30 m
Additional refrigerant	None	300 g

Between 15 m and 30 m, when using a connection pipe other than that in the table, charge additional refrigerant with 20g/m as the criteria.

ELECTRICAL WIRING (OUTDOOR UNIT)

- Service cover removal
 - Remove the two mounting screws.
 - Remove the service cover by pushing downwards.
- Valve cover removal
 - Remove the one mounting screw.
 - Remove the valve cover by sliding upward.
- Connect the power supply cord and the connection cord to terminal.
- Fasten the power supply cord and connection cord with cord clamp.
- Power supply cord and connection cord should be fixed with cable clip as shown in the figure.
- Fill in a gap at the entrance of the cords with insulation (seal).
- Put the service cover and valve cover back after completion of the work.

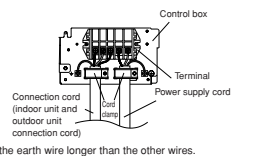

Keep the earth wire longer than the other wires.

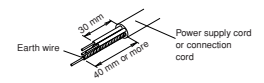

CAUTION

When connecting the power supply cord, make sure that the phase of the power supply matches with the phase of the terminal board. If the phases do not match, the compressor will rotate in reverse and will not be able to compress.

Do not make power supply cord and connection cord come in contact with valve (Gas).

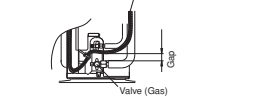

FINISHING

- Insulate the piping.
 - For rear, right, and bottom piping, overlap the connection pipe heat insulation and indoor unit pipe heat insulation and bind them with vinyl tape so that there is no gap.
 - For left and left rear piping, bundle the connection pipe heat insulation and indoor unit pipe heat insulation together and bind them with vinyl tape so that there is no gap.
 - For left and left rear piping, wrap the area which accommodates the rear piping housing section with cloth tape.
 - For left and left rear piping, bind the connection cord to the top of the pipe with vinyl tape.
 - For left and left rear piping, bundle the piping and drain hose together by wrapping them with cloth tape over the range within which they fit into the rear piping housing section.
- Temporarily fasten the connection cord along the connection pipe with vinyl tape. (Wrap to about 1/3 the width of the tape from the bottom of the pipe so that water does not enter.)
- Fasten the connection pipe to the outside wall with saddles, etc.
- Fill the gap between the outside wall pipe hole and the pipe with sealer so that rain water and wind cannot blow in.
- Fasten the drain hose to the outside wall, etc.

Fig. 15

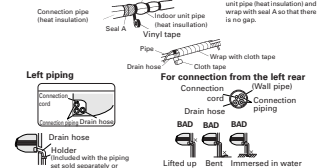

Fig. 16



TEST RUNNING

- Perform test operation and check items 1 and 2 below.
- For the test operation method, refer to the operating manual.
- The outdoor unit, may not operate, depending on the room temperature. In this case, press the test run button on the remote control unit while the air conditioner is running. (Point the transmitter section of the remote control unit toward the air conditioner and press the test run button with the tip of a ball-point pen, etc.)
- To end test operation, press the remote control unit START/STOP button. (When the air conditioner is run by pressing the test run button, the OPERATION indicator lamp and TIMER indicator lamp will simultaneously flash slowly.)

1. INDOOR UNIT

- Is operation of each button on the remote control unit normal?
- Does each lamp light normally?
- Do the air flow-direction louver operate normally?
- Is the drain normal?

2. OUTDOOR UNIT

- Is there any abnormal noise and vibration during operation?
- Will noise, wind, or drain water from the indoor unit disturb the neighbors?
- Is there any gas leakage?

Fig. 17

