

# Panasonic®

## Operating Instructions



### Memory Card Recorder

AJ-SPD850<sub>P</sub>

Model No. AJ-SPD850<sub>E</sub>



### DV

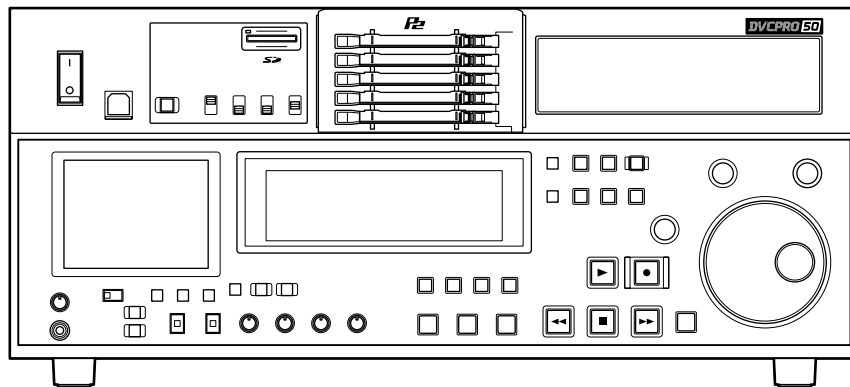

Before operating this product, please read the instructions carefully and save this manual for future use.

**IMPORTANT**

“Unauthorized recording of copyrighted television programmes, video tapes and other materials may infringe the rights of copyright holders and contravene copyright laws.”



CAUTION: TO REDUCE THE RISK OF ELECTRIC SHOCK, DO NOT REMOVE COVER (OR BACK). NO USER-SERVICEABLE PARTS INSIDE. REFER SERVICING TO QUALIFIED SERVICE PERSONNEL.



The lightning flash with arrowhead symbol, within an equilateral triangle, is intended to alert the user to the presence of uninsulated “dangerous voltage” within the product’s enclosure that may be of sufficient magnitude to constitute a risk of electric shock to persons.



The exclamation point within an equilateral triangle is intended to alert the user to the presence of important operating and maintenance (servicing) instructions in the literature accompanying the appliance.

**■ THIS EQUIPMENT MUST BE GROUNDED**

To ensure safe operation, the three-pin plug must be inserted only into a standard three-pin power outlet which is effectively grounded through normal household wiring. Extension cords used with the equipment must have three cores and be correctly wired to provide connection to the ground. Wrongly wired extension cords are a major cause of fatalities.

The fact that the equipment operates satisfactorily does not imply that the power outlet is grounded or that the installation is completely safe. For your safety, if you are in any doubt about the effective grounding of the power outlet, please consult a qualified electrician.

**CAUTION:**

THE AC RECEPTACLE (MAINS SOCKET OUTLET) SHALL BE INSTALLED NEAR THE EQUIPMENT AND SHALL BE EASILY ACCESSIBLE. TO COMPLETELY DISCONNECT THIS EQUIPMENT FROM THE AC MAINS, DISCONNECT THE POWER CORD PLUG FROM THE AC RECEPTACLE.

**WARNING:**

- TO REDUCE THE RISK OF FIRE OR SHOCK HAZARD, DO NOT EXPOSE THIS EQUIPMENT TO RAIN OR MOISTURE.
- TO REDUCE THE RISK OF FIRE OR SHOCK HAZARD, KEEP THIS EQUIPMENT AWAY FROM ALL LIQUIDS. USE AND STORE ONLY IN LOCATIONS WHICH ARE NOT EXPOSED TO THE RISK OF DRIPPING OR SPLASHING LIQUIDS, AND DO NOT PLACE ANY LIQUID CONTAINERS ON TOP OF THE EQUIPMENT.

**CAUTION:**

In order to maintain adequate ventilation, do not install or place this unit in a bookcase, built-in cabinet or any other confined space. To prevent risk of electric shock or fire hazard due to overheating, ensure that curtains and any other materials do not obstruct the ventilation.

**CAUTION:**

TO REDUCE THE RISK OF FIRE OR SHOCK HAZARD AND ANNOYING INTERFERENCE, USE THE RECOMMENDED ACCESSORIES ONLY.

**CAUTION:**

TO REDUCE THE RISK OF FIRE OR SHOCK HAZARD, REFER MOUNTING OF THE OPTIONAL INTERFACE BOARDS TO QUALIFIED SERVICE PERSONNEL.

**Notice (U.S.A. only):**

This product has a fluorescent lamp that contains a small amount of mercury. It also contains lead in some components. Disposal of these materials may be regulated in your community due to environmental considerations. For disposal or recycling information please contact your local authorities, or the Electronics Industries Alliance: <<http://www.eiae.org>>

**CAUTION:**

TO REDUCE THE RISK OF FIRE OR SHOCK HAZARD, REFER CHANGES OF SWITCH SETTINGS INSIDE THE UNIT TO QUALIFIED SERVICE PERSONNEL.

**CAUTION:**

- Keep the temperature inside the rack to between 41°F to 104°F (5°C to 40°C).
- Bolt the rack securely to the floor so that it will not topple over when the deck is drawn out.

**FCC Note:**

This equipment has been tested and found to comply with the limits for a class A digital device, pursuant to Part 15 of the FCC Rules. These limits are designed to provide reasonable protection against harmful interference when the equipment is operated in a commercial environment. This equipment generates, uses, and can radiate radio frequency energy, and if not installed and used in accordance with the instruction manual, may cause harmful interference to radio communications. Operation of this equipment in a residential area is likely to cause harmful interference in which case the user will be required to correct the interference at his own expense.

**Warning:** To assure continued FCC emission limit compliance, the user must use only shielded interface cables when connecting to external units. Also, any unauthorized changes or modifications to this equipment could void the user's authority to operate it.

**CAUTION:**

This apparatus can be operated at a voltage in the range of 100 – 240 V AC. Voltages other than 120 V are not intended for U.S.A. and Canada.

**CAUTION:**

Operation at a voltage other than 120 V AC may require the use of a different AC plug. Please contact either a local or foreign Panasonic authorized service center for assistance in selecting an alternate AC plug.

# Caution for AC Mains Lead

**FOR YOUR SAFETY PLEASE READ THE FOLLOWING TEXT CAREFULLY.**

This product is equipped with 2 types of AC mains cable. One is for continental Europe, etc. and the other one is only for U.K.

Appropriate mains cable must be used in each local area, since the other type of mains cable is not suitable.

**FOR CONTINENTAL EUROPE, ETC.**

Not to be used in the U.K.

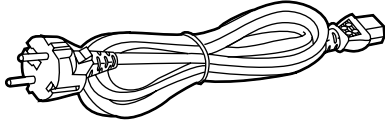

**FOR U.K. ONLY**

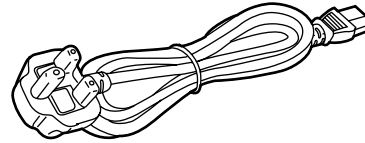

**FOR U.K. ONLY**

This appliance is supplied with a moulded three pin mains plug for your safety and convenience.

A 13 amp fuse is fitted in this plug.

Should the fuse need to be replaced please ensure that the replacement fuse has a rating of 13 amps and that it is approved by ASTA or BSI to BS1362.

Check for the ASTA mark  or the BSI mark  on the body of the fuse.

If the plug contains a removable fuse cover you must ensure that it is refitted when the fuse is replaced.

If you lose the fuse cover the plug must not be used until a replacement cover is obtained.

A replacement fuse cover can be purchased from your local Panasonic Dealer.

**How to replace the fuse**

1. Open the fuse compartment with a screwdriver.

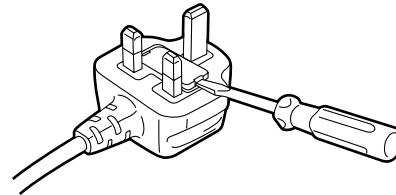

2. Replace the fuse.

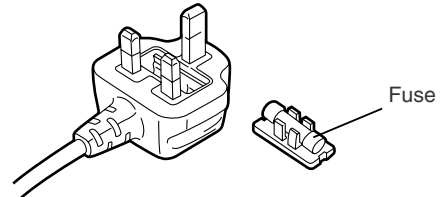

## For AJ-SPD850E

### IMPORTANT

“Unauthorized recording of copyrighted television programmes, video tapes and other materials may infringe the rights of copyright holders and contravene copyright laws.”

### Operating precaution

Operation near any appliance which generates strong magnetic fields may give rise to noise in the video and audio signals. If this should be the case, deal with the situation by, for instance, moving the source of the magnetic fields away from the unit before operation.

#### ■ THIS EQUIPMENT MUST BE EARTHED

To ensure safe operation, the three-pin plug must be inserted only into a standard three-pin power point which is effectively earthed through normal household wiring.

Extension cords used with the equipment must have three cores and be correctly wired to provide connection to the earth. Wrongly wired extension cords are a major cause of fatalities.

The fact that the equipment operates satisfactorily does not imply that the power point is earthed or that the installation is completely safe. For your safety, if you are in any doubt about the effective earthing of the power point, please consult a qualified electrician.

#### ■ DO NOT REMOVE PANEL COVERS BY UNSCREWING THEM.

To reduce the risk of electric shock, do not remove the covers. No user serviceable parts inside. Refer servicing to qualified service personnel.

#### WARNING:

- TO REDUCE THE RISK OF FIRE OR SHOCK HAZARD, DO NOT EXPOSE THIS EQUIPMENT TO RAIN OR MOISTURE.
- TO REDUCE THE RISK OF FIRE OR SHOCK HAZARD, KEEP THIS EQUIPMENT AWAY FROM ALL LIQUIDS. USE AND STORE ONLY IN LOCATIONS WHICH ARE NOT EXPOSED TO THE RISK OF DRIPPING OR SPLASHING LIQUIDS, AND DO NOT PLACE ANY LIQUID CONTAINERS ON TOP OF THE EQUIPMENT.

#### CAUTION:

TO REDUCE THE RISK OF FIRE OR SHOCK HAZARD AND ANNOYING INTERFERENCE, USE THE RECOMMENDED ACCESSORIES ONLY.

#### CAUTION:

TO REDUCE THE RISK OF FIRE OR SHOCK HAZARD, REFER MOUNTING OF THE OPTIONAL INTERFACE BOARDS TO AUTHORIZED SERVICE PERSONNEL.

#### CAUTION:

TO REDUCE THE RISK OF FIRE OR SHOCK HAZARD, REFER CHANGES OF SWITCH SETTINGS INSIDE THE UNIT TO QUALIFIED SERVICE PERSONNEL.

#### CAUTION:

In order to maintain adequate ventilation, do not install or place this unit in a bookcase, built-in cabinet or any other confined space. To prevent risk of electric shock or fire hazard due to overheating, ensure that curtains and any other materials do not obstruct the ventilation.

#### CAUTION:

- Keep the temperature inside the rack to between 5°C to 40°C.
- Bolt the rack securely to the floor so that it will not topple over when the deck is drawn out.

#### CAUTION:

THE AC RECEPTACLE (MAINS SOCKET OUTLET) SHALL BE INSTALLED NEAR THE EQUIPMENT AND SHALL BE EASILY ACCESSIBLE. TO COMPLETELY DISCONNECT THIS EQUIPMENT FROM THE AC MAINS, DISCONNECT THE POWER CORD PLUG FROM THE AC RECEPTACLE.

#### Disposal of old equipment

Batteries, packaging and old equipment should not be disposed of as domestic waste, but in accordance with the applicable regulations.



#### Attentie

Voor de primaire voeding en het reservegeheugen van het apparaat. alsmede voor de afstandsbediening, wordt gebruik gemaakt van een batterij.

Wanneer de batterij uitgeput is, mag u deze niet gewoon weggooien, maar dient u ze als klein chemisch afval weg te doen.



# Contents

Introduction .....	7
Included accessories .....	7
Options .....	7
Features .....	8
Control reference guide .....	10
• Front Panel .....	10
• Display .....	15
• Rear Panel .....	16
Recording and playing .....	18
• Inserting P2 cards .....	18
• Removing P2 cards .....	18
• Protecting against a possible erasure .....	19
• P2 card access LEDs and P2 card status .....	19
Connections .....	20
Jog/Shuttle (Search dial) .....	21
Working with clip thumbnails .....	22
Play List .....	34
• Using the play list .....	34
List of shortcuts .....	39
Setup (Initial settings) .....	40
Setup menus .....	41
• SYSTEM menu .....	43
• USER menus .....	44
<BASIC> .....	44
<OPERATION> .....	48
<INTERFACE> .....	50
<EDIT> .....	51
<TIME CODE> .....	52
<VIDEO> .....	53
<AUDIO> .....	56
<V BLANK> .....	58
<MENU> .....	62
Time code, user bit and CTL .....	63
Superimpose screen .....	64
Video output signals and servo reference signal .....	65
Audio V fade function .....	66
Audio recording channel and monitor output selection .....	67
Printed circuit board .....	67

Rack mounting .....	68
Condensation .....	69
Maintenance .....	69
Error messages .....	70
RS-232C interface .....	74
Connector signals .....	77
Specifications .....	78

## Information on software for this product

1. Included with this product is software licensed under the GNU General Public License (GPL) and GNU Lesser General Public License (LGPL), and users are hereby informed that they have the right to obtain, change and redistribute the source codes of this software.

Details on GPL and LGPL can be found on the installation CD provided with the unit. Refer to the folder called "LDOC".

(Details are given in the original (English-language) text.)

To obtain the source codes, go to the following home page:<http://panasonic.biz/sav/>

The manufacturer asks users to refrain from directing inquiries concerning the source codes they have obtained and other details to its representatives.

2. Included with this product is software which is licensed under ICU-License.

Details on ICU-License can be found on the installation CD provided with the unit. Refer to the folder called "LDOC".

(Details are given in the original (English-language) text.)

3. Included with this product is software which is licensed under Apache-License.

Details on Apache-License can be found on the installation CD provided with the unit. Refer to the folder called "LDOC".

(Details are given in the original (English-language) text.)

# Introduction

---

The AJ-SPD850 is a memory card recorder that has five slots for cards (such as the AJ-P2C002SG which is sold separately) that conform to the PC card type II standard. It can record and play video and audio in the DVCPRO50, DVCPRO, and DV compression formats.

It has a 3.5-inch color LCD for simple setting and confirmation of video. It also allows searches and play of video and audio with the thumbnail screen.

You can also select and play parts of the video and audio recorded on cards in the memory card recorder, in an order you can specify.

You can also use it just like a regular player for use with a VTR.

## Included accessories

---

■ 3-pin power cord x 1

■ CD-ROM x 1

## Options

---

■ SDI interface board  
AJ-YA755G

■ IEEE1394 interface board  
AJ-YAD850G

■ Rack-mounting adapters  
AJ-MA75P

■ DVD drive unit  
AJ-DVD850G

Only use the above-listed boards as optional boards.

# Features

---

## ■ Recording and play of files on memory cards

The memory card recorder can record to and play video and audio on memory cards (such as the AJ-P2C002SG which is sold separately; henceforth referred to as “P2 cards”) in the DVCPRO50, DVCPRO, and DV compression formats. Video and audio data is recorded on the cards in the form of MXF file (SMPTE390M) and clip meta data in XML.

## ■ 5 PC card slots

The unit comes with five PC card slots into which you can insert PC card type II cards. You can record and play audio and video material on the P2 cards you have inserted into these slots.

## ■ Video monitor

The 3.5-inch color LCD monitor allows to find and play video, using such features as the thumbnail screen.

## ■ Play list feature

Use the IN/OUT and ENTRY buttons on the front panel to create and play play lists. Just choose the parts you want recorded on any of the five P2 cards in the memory card recorder, and put them in the order you want them to play. You can then record these play lists to an SD memory card.

## ■ Dial jog/Dial shuttle

The jog makes it possible to play in slow motion at rates between  $-1.0$  and  $+1.0$ . The shuttle allows high speed play in either direction at up to 100 times normal speed. At speeds up to 10 x, the sound is also audible.

## ■ Time codes/player function for editing

The memory card recorder has a built-in time code generator (TCG) and time code reader (TCR). In addition to the internal time code, external time code input or input signal VITC can be recorded on the memory card recorder as the time code. The memory card recorder can also be used as a player for an editing system with RS-422A.

## ■ Video encoder control

The encoder controls on the front panel allow you to adjust the video output level, chroma, setup, and hue (chroma phase).

## ■ Switching between 525i and 625i TV systems

Select the TV system (525i or 625i in setup menu No. 070) to match the video input signal to play and record the different TV system signals.

## ■ Multifunctional interface

### • Analog video input/output

Both composite and component signal inputs/outputs are provided.

### • AES/EBU audio input/output

Digital audio input and output connectors are provided.

### • Serial digital input/output

Fit the optional SDI interface board (optional: AJ-YA755G) to enable interfacing of the serial digital component signals.

### • IEEE1394 digital input/output

Fit the optional IEEE1394 interface board (optional: AJ-YAD850G) to enable input/output interfacing of IEEE1394 digital signals.

### • RS232C remote

A RS232C remote connector is provided.

### • USB 2.0

By connecting a personal computer with USB 2.0, you can use the P2 cards in the memory card recorder as mass storage. You will need to install the USB driver onto your computer.

### • LAN

You can connect to a network with a 100BASE-TX /10BASE-T.

## ■ 4-channel, high-sound-quality digital audio

The 4-channel PCM audio enables independent recording for all four channels in addition to channel mixing.

## ■ Menu-based setup

Perform setup while viewing the setup menus on the memory card recorder’s display (vacuum fluorescent display), the 3.5-inch LCD, or a TV monitor connected through an OUT 3 connector.

## ■ Rack mounting

Use the optional rack adapter (AJ-MA75P) to attach this 4U-sized deck to a 19-inch rack.



## Features (continued)

---

### ■ Recording times (1 Card)

Card model	Recording format	
	DVCPRO (2-channel audio)	DVCPRO50 (4-channel audio)
AJ-P2C002SG	approx. 8 minutes	approx. 4 minutes
AJ-P2C004HG	approx. 16 minutes	approx. 8 minutes
AJ-P2C008HG	approx. 32 minutes	approx. 16 minutes

(For details, see the operating instructions for the memory card.)

#### •Dividing clips over 4 GB in length

If the one-time continuous recording exceeds the duration given in the table below when a P2 card with a memory capacity of 8 GB or more is used in this unit, the recording will automatically be continued as a separate clip. When performing thumbnail operations (display, delete, repair or copy) for clips using a P2 series product, the operations can be performed for the entire recording as a single clip.

With nonlinear editing software or a personal computer, the recording may be displayed as separate clips.

Recording format	Recording duration
DVCPRO50	approx. 10 minutes
DVCPRO/DV	approx. 20 minutes

### ■ For the latest information on P2 cards and SD memory cards:

For the latest information not available in the Operating Instructions, visit the P2 Support Desk at the following Web sites.

For Japanese: <http://panasonic.biz/sav/>

For English: <https://eww.pavc.panasonic.co.jp/pro-av/>

# Control reference guide

## Front panel — Upper section

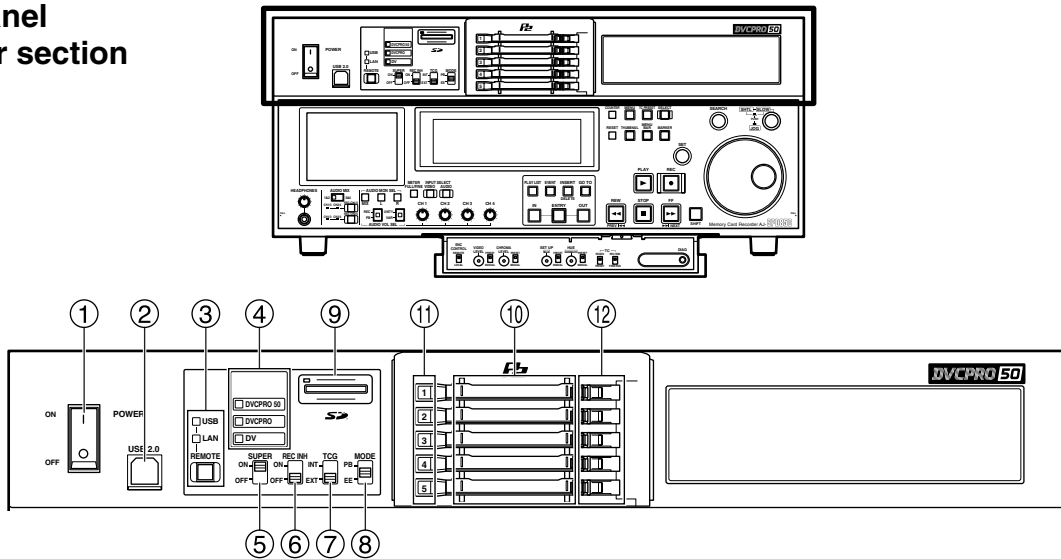

### ① POWER switch

Use when switching between ON and OFF of the power.

### ② USB 2.0 connector (Type B)

Use when connecting a personal computer (See page 20).

### ③ REMOTE button and REMOTE display

Use when operating the memory card recorder under external control or copying files on P2 cards through the 9-pin REMOTE, RS-232C, LAN, or USB 2.0 terminal. When the REMOTE button is pressed, the REMOTE display changes as follows: [Lights out] → [REMOTE lights] → [Lights out]. When it is pressed while holding down the SHIFT button, the displays change as follows: [Lights out/REMOTE lights] → [LAN lights] → [USB lights] → [Lights out]. (These operations are not performed while thumbnails or play lists are displayed.)

#### REMOTE button lights:

You can operate the memory card recorder under external control set at setup menu No. 201 (9P SEL) or No. 204 (RS232C SEL).→

#### LAN lights:

You can check files on P2 cards with a personal computer on the network through 100BASE-TX /10BASE-T connection. At this time, front panel controls of the memory card recorder are disabled.

#### USB lights:

By connecting a personal computer with USB2.0, you can use the P2 cards in the memory card recorder as mass storage. At this time, front panel controls of the memory card recorder are disabled. You will need to install the USB driver onto your computer.

### ④ Format display area

Shows the recording format and the format of the files recorded on the P2 card.

**DVCPRO50** : This indicates recording and playback of DVCPRO50 (50 Mbps) format.

**DVCPRO** : This indicates recording and playback of DVCPRO (25 Mbps) format.

**DV** : This indicates recording and playback of DV format.

### ⑤ SUPER switch

**ON** : The time code and other superimposed information are output to the VIDEO OUT 3 connector, and when the SDI OUT 3 connector (optional) is provided, they

are output to this connector as well.

**OFF**: The superimposed information is not output.

### ⑥ REC INH switch

This switch is used to enable or disable recording to P2 cards.

**ON** : Recording is disabled (inhibited).

The REC INH lamp lights on the display panel.

**OFF**: Recording is enabled so long as the write-protect switch mechanism on the card is set to enable recording.

### ⑦ TCG switch

**INT** : The internal time code generator is used.

**EXT**: The external time code which is input from the time code input connector or video signal VITC is used. Select at setup menu No. 505 (EXT TC SEL).

### ⑧ MODE switch

This switch is used to select the signals in the stop mode.

**PB** : The signal from the card is output.

**EE** : The input signal selected by the INPUT SELECT button is output.

### ⑨ SD memory card slot

Insert an SD memory card.

**Insert** : With the label facing up and the cut-corner facing in, press until the card locks in place.

**Eject** : After checking that the lamp has gone off, press the card in to release the lock.

#### Note:

Insert only SD memory cards: do not insert any other type of cards.

### ⑩ P2 card slots

Press the card in until the eject button pops out. After inserting the card, push the button over (See page 18).

### ⑪ P2 card access LEDs

See page 19.

### ⑫ EJECT buttons

Press to eject the card. Raise the button and press firmly.

Do not use this button while the card's access indicator is on (See page 18).

# Control reference guide (continued)

## Front panel — Under section (1/3)

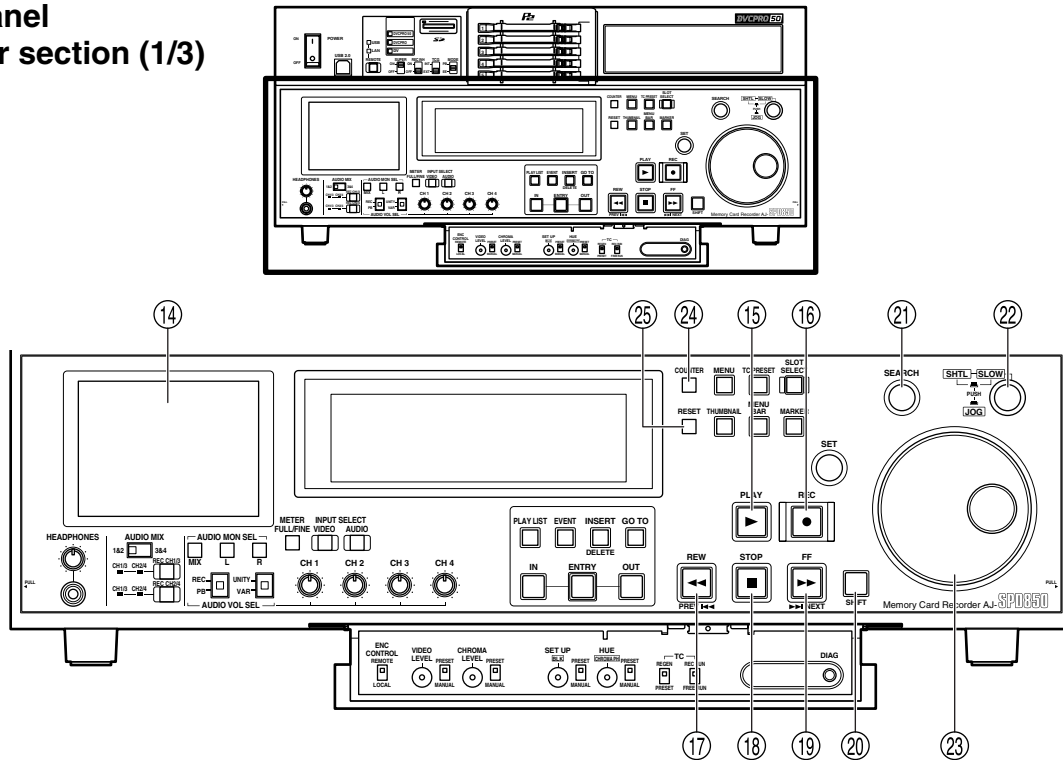

⑭ **3.5-inch color LCD monitor**

Use thumbnails and other features to find and check video and audio.

⑮ **PLAY button**

Press to start playback.  
Press together with the REC button to start recording.

⑯ **REC button**

Recording starts when this button is pressed in the stop mode while holding down the PLAY button.  
Press this button in the stop mode with the MODE switch at the PB setting to monitor E-E mode pictures and audio signals. The original pictures and sound are restored when the STOP button is pressed.

⑰ **REW/PREV button**

Press to rewind.  
Select the speed at setup menu No. 102 (FF. REW MAX).  
Press the REW button while pressing the SHIFT button with the MODE switch at the PB setting to find the previous clip<sup>※1</sup>. In the case of clips whose data spans a multiple number of P2 cards, you can find the beginning of the next card.

※1 Regarding the clip:

The clip is a data group that contains video, audio, and added information and that is created with one-time operation of recording and stop.

Repeating this operation can create two or more clips.

The picture when starting recording is displayed in the thumbnail as a typical example of clips.

⑱ **STOP button**

Press to stop. If the MODE switch is set to PB, you can monitor still pictures.

⑲ **FF/NEXT button**

Press to fast forward.  
Select the speed at setup menu No. 102 (FF. REW MAX).  
Press the FF button while pressing the SHIFT button with the MODE switch at the PB setting to find the next clip and the beginning of the card.

⑳ **SHIFT button**

Press in combination with the FF and REW buttons.

㉑ **SEARCH button**

Press to search.  
Set the search dial to the shuttle mode and turn to the desired position and playback starts at the set speed after pressing the SEARCH button.

㉒ **SHTL/SLOW button**

Select whether to use the search dial for SHTL or SLOW.  
Each time you press it, the search dial alternates between SHTL and SLOW.

㉓ **Search dial**

Locate the edit points.  
Each time it is pressed, it is set alternatively to the SHTL/SLOW mode or the JOG mode, and the JOG, SHTL or SLOW lamp lights.  
When the power is turned on, the search dial will not operate unless it is first returned to the STILL position (See page 21).

㉔ **COUNTER button**

Each time you press this button, the counter display changes as follows: [CTL] → [TC] → [UB].

㉕ **RESET button**

Press in the CTL mode to reset the counter to [0:00:00:00].  
Press while holding down the TC PRESET button in the TC or UB mode to reset the time code generator.

# Control reference guide (continued)

## Front panel — Under section (2/3)

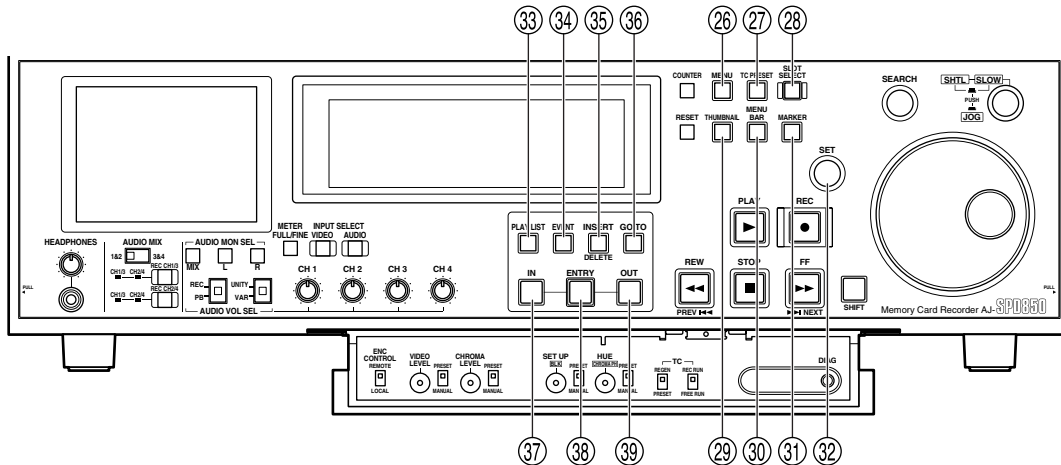

### 26 MENU button

Press to show the setup menus on the 3.5-inch color LCD and the TV monitor (when using the VIDEO OUT 3 or SDI OUT 3 connector (optional)). The setup menu numbers appear on the memory card recorder's display panel.

Press again to exit the setup menu and restore the original status.

### 27 TC PRESET button

Set the TC or UB value (See page 63).

When setting the TC or UB value, press this button first to stop the data. The set of digits whose display is flashing is then changed. (However, the button and display will not function while thumbnails are displayed.)

### 28 SLOT SELECT button

In the stop status, use this to set the P2 card on which the recording is to begin.

Each time you press this button, the numbers of the slots you can record to appear in order.

### 29 THUMBNAIL button

Press this and the button lights and thumbnails appear on the 3.5-inch color LCD and TV monitor.

Press again to exit the thumbnail screen. The button also goes dim.

### 30 MENU BAR button

When this button is pressed while the thumbnail screen is displayed, the MENU BAR button lights, and the pointer that indicates the operation position can be moved to the menu at the bottom of the display.

Press again to restore the original status.

### 31 MARKER button

Press to switch clip markers on and off.

In the thumbnail screen, press to switch on or off the marker in the clip indicated by the cursor.

### 32 SET button

Press to confirm settings in the thumbnail screen, in the setup menus and when creating play lists.

### 33 PLAYLIST button

Press when creating play lists or to play according to a play list. The button lights and the play list screen appears on the 3.5-inch color LCD and the TV monitor (when using the VIDEO OUT 3 or SDI OUT 3 connector (optional)).

Press again to exit the play list screen. The button goes off or flashes depending on the status of access to the clips.

### 34 EVENT button

While the PLAYLIST button is lit, press and it lights and you can enter events (IN and OUT points).

Press again to exit the mode. The button also goes dim.

### 35 INSERT/DELETE button

Press to insert or delete play list events.

While a play list is being displayed (the PLAYLIST button lights), select the event you want to insert and press this button to insert the event.

While a play list is being displayed (the PLAYLIST button lights), select the event you want to delete and, while pressing the SHIFT button, press this button to delete the event.

### 36 GO TO button

Press to move to events in a registered play list.

While a play list is being displayed (the PLAYLIST button lights), select the event and, while pressing the IN (or OUT) button, press this button to move the cursor to the IN (or OUT) point.

### 37 IN button

Use when creating play lists.

In the play list creation mode (the PLAYLIST and EVENT buttons light) press this button together with the ENTRY button to set the IN point.

Press together with the RESET button to clear an IN point you have set.

### 38 ENTRY button

Use when creating play lists.

In the play list creation mode (the PLAYLIST and EVENT buttons light) press this button together with the IN (or OUT) button to set the IN (or OUT) point.

### 39 OUT button

Use when creating play lists.

In the play list creation mode (the PLAYLIST and ENTRY buttons light) press this button together with the ENTRY button to set the OUT point.

Press together with the RESET button to clear an OUT point you have set.

# Control reference guide (continued)

## Front panel — Under section (3/3)

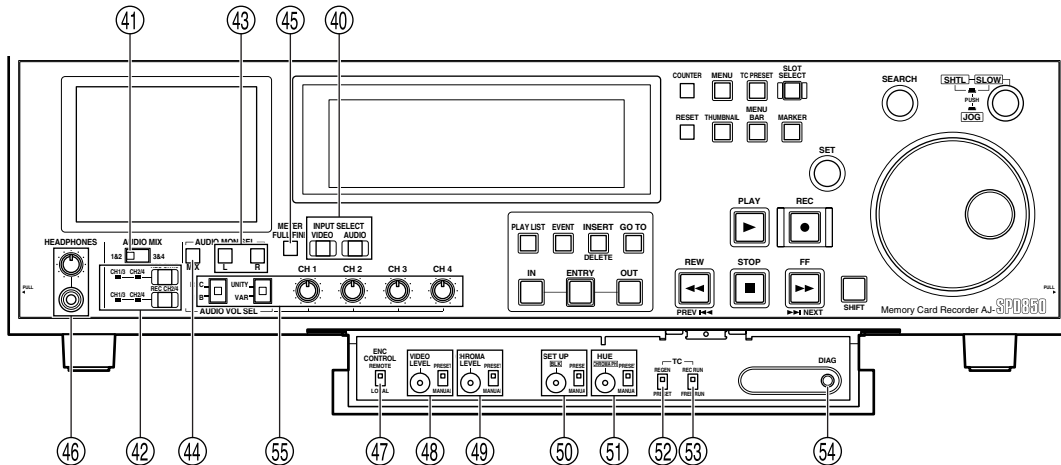

### 40 INPUT SELECT buttons

Switch the video and audio input signals. You can also switch the video input signals to the internal signal selected at setup menu No. 600 (INT SG).

#### VIDEO:

Each time the VIDEO button is pressed, the input video signal switches: [Y PB PR] → [CMPST] → [SDI](optional) → [1394](optional) → [SG (SG/SG1/SG2)].

When SG is selected, the signal switches to the internal signal selected at setup menu No. 600 (INT SG).

#### AUDIO:

Each time the AUDIO button is pressed, the input audio signal switches: [ANALOG] → [AES/EBU] → [USER SET] → [SDI](optional) → [1394](optional) → [SG].

USER SET enables you to select and record the input signals separately on PCM audio signal channels 1 through 4. Use in conjunction with the setup menu.

#### Example: Settings

AUDIO button  
 USER SET  
 Setup menus  
 No. 715 (CH1 IN SEL): ANA  
 No. 716 (CH2 IN SEL): DIGI  
 No. 717 (CH3 IN SEL): DIGI  
 No. 718 (CH4 IN SEL): ANA  
 No. 719 (D IN SEL12): AES  
 No. 720 (D IN SEL34): SIF  
**PCM audio signals to be recorded on the card**  
 CH1 : Analog input signals  
 CH2 : AES/EBU digital signals  
 CH3 : SDI input digital signals  
 CH4 : Analog input signals

#### Notes:

- You can inhibit input switching (video and audio) of the INPUT SELECT buttons with setup menus No. 112 (V IN SEL INH) and No. 113 (A IN SEL INH).
- You cannot select SDI and 1394 unless you have installed the optional board (AJ-YA755G, AJ-YAD850G).

### 41 AUDIO MIX switch

Select the audio signals to be recorded to audio channels CH1/CH2/CH3/CH4.

**1&2** : Switch the input to CH1 with REC CH1/CH3.

Switch the input to CH2 with REC CH2/CH4.

**3&4** : Switch the input to CH3 with REC CH1/CH3.

Switch the input to CH4 with REC CH2/CH4.

### 42 REC CH1/CH3 button and REC CH2/CH4 button

Select the audio signals to be recorded to audio channels CH1/CH2/CH3/CH4.

**When the AUDIO MIX switch 41 is at the [1&2] setting, the setting is switched by one step in the sequence of A → B → C each time the REC CH1/3 button is pressed.**

(■ ON; □ OFF)

CH1/3 CH2/4

- |   |   |   |  |
|---|---|---|--|
| A | ■ | □ | The CH1 signals are recorded on CH1.     |
| B | □ | ■ | The CH2 signals are recorded on CH1.     |
| C | ■ | ■ | The CH1+CH2 signals are recorded on CH1. |

**When the AUDIO MIX switch 41 is at the [1&2] setting, the setting is switched by one step in the sequence of A → B → C each time the REC CH2/4 button is pressed.**

(■ ON; □ OFF)

CH1/3 CH2/4

- |   |   |   |  |
|---|---|---|--|
| A | □ | ■ | The CH2 signals are recorded on CH2.     |
| B | ■ | ■ | The CH1+CH2 signals are recorded on CH2. |
| C | ■ | □ | The CH1 signals are recorded on CH2.     |

**When the AUDIO MIX switch 41 is at the [3&4] setting, the setting is switched by one step in the sequence of A → B → C each time the REC CH1/3 button is pressed.**

(■ ON; □ OFF)

CH1/3 CH2/4

- |   |   |   |  |
|---|---|---|--|
| A | ■ | □ | The CH3 signals are recorded on CH3.     |
| B | □ | ■ | The CH4 signals are recorded on CH3.     |
| C | ■ | ■ | The CH3+CH4 signals are recorded on CH3. |

## Control reference guide (continued)

When the **AUDIO MIX** switch ④① is at the [3&4] setting, the setting is switched by one step in the sequence of **A** → **B** → **C** each time the **REC CH2/4** button is pressed.

(■ ON; □ OFF)  
CH1/3 CH2/4

- |   |                                     |                                     |  |
|---|-------------------------------------|-------------------------------------|--|
| A | <input type="checkbox"/>            | <input checked="" type="checkbox"/> | The CH4 signals are recorded on CH4.     |
| B | <input checked="" type="checkbox"/> | <input checked="" type="checkbox"/> | The CH3+CH4 signals are recorded on CH4. |
| C | <input checked="" type="checkbox"/> | <input type="checkbox"/>            | The CH3 signals are recorded on CH4.     |

### ④③ AUDIO MONITOR SELECT (L/R)

Switch the audio signal to be output to the MONITOR L/R connectors.

Each time you press the L button, the signals output to the MONITOR L connector switches: [CH1] → [CH2] → [CH3] → [CH4].

Each time you press the R button, the signals output to the MONITOR R connector switches: [CH1] → [CH2] → [CH3] → [CH4].

You can check which signal is currently selected by seeing which of the L/R lamps in the level meter is lit.

### ④④ MONITOR MIX button

This button is used to select the mixed signals which are to be output to the MONITOR L and R connectors.

Each time the MONITOR SELECT L button is pressed while this button is held down, the signals to be output to the MONITOR L connector change in the following sequence: [CH1+CH2] → [CH3+CH4] → [CH1+CH3] → [CH2+CH4] → mixing release.

The mixed signals to be output to the MONITOR R connector are changed in the same way by the MONITOR SELECT R button.

### ④⑤ METER (FULL/FINE) selector button

Select the scale display for the audio level meter (See page 15).

#### FULL mode:

The standard scale ( $-\infty$  to 0 dB).

#### FINE mode:

Scale in 0.5 dB increments.

“■” indicates the standard level of -20 dB (-18 dB),

and each of the dots “•” indicates a 1 dB scale increment.

### ④⑥ Headphone jack and volume control

Connect stereo headphones to monitor the sound during recording or playback.

### ④⑦ ENC CONTROL (REMOTE/LOCAL)

Select whether encoder control is to be done on the memory card recorder or another deck.

**REMOTE** : Encoder control is done remotely.

**LOCAL** : Encoder control is done on the memory card recorder.

### ④⑧ VIDEO LEVEL dial and switch

When ENC CONTROL is set to [LOCAL], you can adjust the video output level.

When set to [PRESET], the video output level is a unity value (0 dB).

When set to [MANUAL], you can adjust the level with the dial.

### ④⑨ CHROMA LEVEL dial and switch

When ENC CONTROL is set to [LOCAL], you can adjust the chroma level.

When set to [PRESET], the chroma level is a unity value (0 dB).

When set to [MANUAL], you can adjust the level with the dial.

### ④⑩ SET UP LEVEL dial and switch

When ENC CONTROL is set to [LOCAL], you can adjust the setup level.

When set to [PRESET], the setup level is a unity value (0 IRE).

When set to [MANUAL], you can adjust the level with the dial.

### ④⑪ HUE LEVEL dial and switch

When ENC CONTROL is set to [LOCAL], you can adjust the hue.

When set to [PRESET], the hue is a unity value (0 °).

When set to [MANUAL], you can adjust the hue with the dial.

### ④⑫ TC REGEN/PRESET switch

#### REGEN:

The internal time code generator synchronizes with the time code read by the time code reader from the card.

Select whether to make TC or UB the REGEN in Setup Menu No. 503 (TCG REGEN).

#### PRESET:

You can preset with the control panel or remote control.

### ④⑬ TC REC RUN/FREE RUN switch

#### REC RUN:

The time code runs only while recording.

If REGEN/PRESET is set to [REGEN], the time code runs constantly.

#### FREE RUN:

The time code runs when the memory card recorder is on, irrespective of the operating mode.

### ④⑭ DIAG button

Press to show information about the memory card recorder. Press again to return to the previous display. (However, the button and display will not function while thumbnails are displayed.)

The HOURS METER information, WARNING information and UMID information are shown as the unit's information.

Press the SEARCH button to switch among the three.

HOURS METER shows the memory card recorder's serial number, the number of hours it has been on, and the number of times it has been switched on and off.

WARNING shows warnings.

### ④⑮ AUDIO VOL SEL switches

#### REC/PB switch

REC: The recording level can be adjusted using the audio level controls.

PB: The playback level can be adjusted using the audio level controls.

#### UNITY/VAR switch

UNITY: The audio signals are recorded and played back at a fixed level regardless of the positions of the audio level controls.

VAR: The audio signals are recorded and played back at the levels adjusted using the audio level controls.

#### Audio level controls

Use these to adjust the recording and playback levels of the audio signals (CH1/CH2/CH3/CH4).



# Control reference guide (continued)

## Display

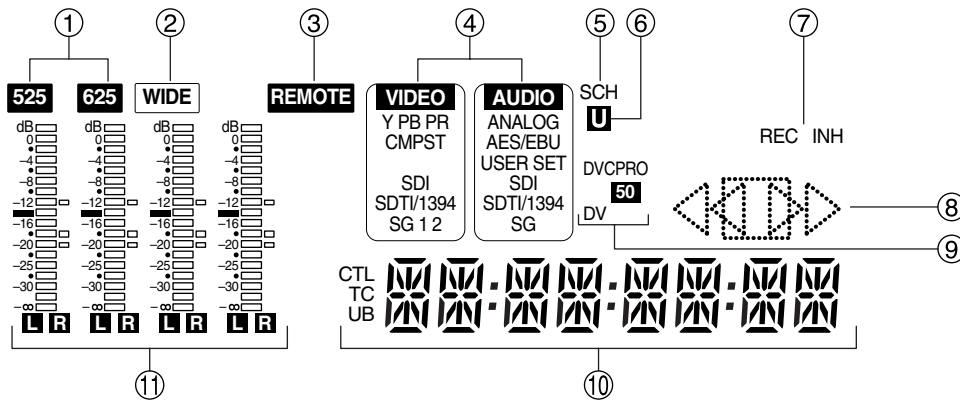

### ① TV system displays

The selected TV system is displayed here. Switch between 525 interlace and 625 interlace in setup menu No. 070 (TV SYSTEM) (See page 47).

**525** : lights when 525 interlace TV system is selected.

**625** : lights when 625 interlace TV system is selected.

### ② WIDE lamp

Lights when recording the 16:9 wide-screen information. You can select the recording of the wide-screen information using setup menu No. 645 (WIDE SELECT). During playback, the lamp lights when wide-screen information has been recorded.

### ③ REMOTE lamp

Lights when the CONTROL switch is set to [REMOTE].

### ④ INPUT SELECT display area

The indicator for the selected input signal lights. Except for analog audio signals, the indicator flashes if there is no input of the selected signal type.

#### VIDEO

- Y PB PR** : Analog component video signals
- CMPST** : Analog composite video signals
- SDI** : Serial digital video signals (option)
- SDTI/1394** : Compressed digital signals (option)
- SG/SG 1/SG 2** : Internal reference signals

#### AUDIO

- ANALOG** : Analog audio signals
- AES/EBU** : Digital audio signals
- USER SET** : Recording audio signal selection
- SDI** : Serial digital audio signals (option)
- SDTI/1394** : Compressed digital signals (option)
- SG** : Internal reference signals

### ⑤ SCH lamp

Lights when the SCH phase of the external synchronized signal (REF VIDEO) is inside the prescribed range. At all other times, the lamp is off.

### ⑥ U lamp

In the E-E mode, this lights when the input signals contain UMID information. During playback, it lights when UMID information has been recorded.

### ⑦ REC and REC INH lamps

**REC:**  
lights when recording.

### REC INH:

Lights when recording is inhibited (the REC INH switch on the upper front panel is set to [ON] or all the P2 cards are write-protected). In this status, recording is not possible.

### ⑧ Operation mode displays

The card transport status is displayed here.

- ▷ : Normal playback or recording
- ◁▷ : Playback at a speed slower than 1 x
- ◁▷▷ : Playback at a speed faster than 1 x
- ▷▷ : Fast forwarding (FF)
- ◁◁ : Reverse playback at 1 x
- ◁◁◁ : Reverse playback at a speed slower than 1 x
- ◁◁◁◁ : Reverse playback at a speed faster than 1 x
- ◁◁◁◁◁ : Rewinding (REW)
- ◻◻ : Pause/still

### ⑨ Format displays

The recording format and the format of the card inserted in the memory card recorder are displayed here.

### ⑩ Counter display

The card counter, time code, etc. are displayed here. The type of value displayed is indicated by CTL, TC or UB.

### ⑪ Level meters

These meters indicate the levels of CH1, CH2, CH3, and CH4 of the PCM audio signals. During recording or while E-E is selected, the levels of the audio input signals appear; during playback, the levels of the audio output signals appear. Use the METER selector button to switch the audio level display between FULL and FINE mode (See page 14).

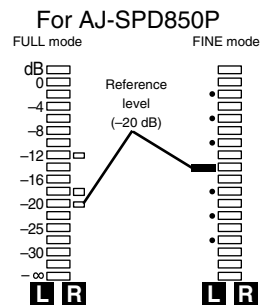

(For AJ-SPD850E, reference level: -18 dB)

Each of the dots “•” indicates a 1 dB scale increment.

# Control reference guide (continued)

## Rear Panel (1/2)

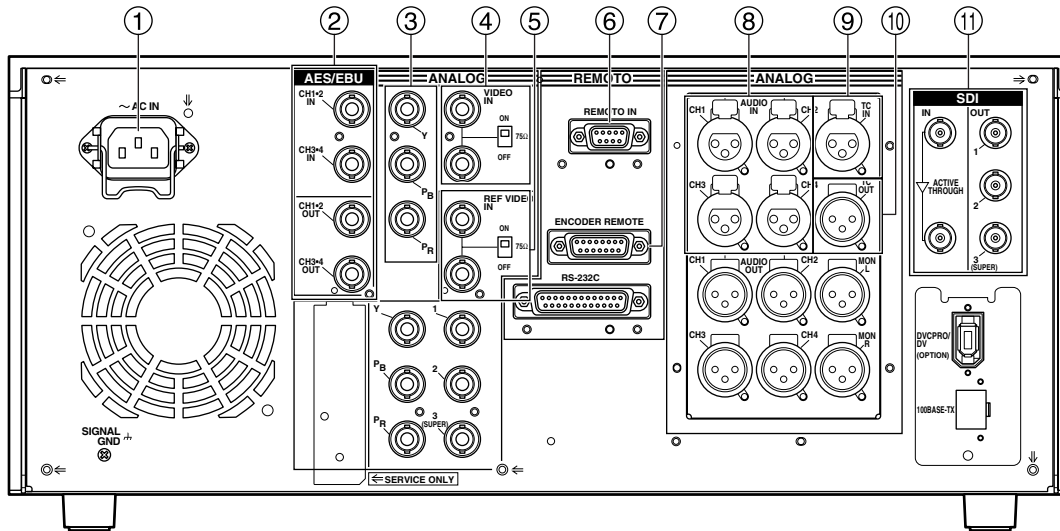

### ① AC IN socket

Connect one end of the power cord supplied to this socket and the other end to the power outlet.

### ② DIGITAL AUDIO IN and OUT connectors

These are the input and output connectors for digital audio signals that comply with the AES/EBU standards.

#### Note:

The digital audio signals must be synchronized with the video input signals; otherwise noise will be generated in the audio output signals.

### ③ ANALOG COMPONENT VIDEO IN connectors

The analog component video signals are input to these connectors.

### ④ ANALOG COMPOSITE VIDEO IN connectors and 75 $\Omega$ termination switch

Input connectors for analog composite video signals. A loop-through configuration is featured for each pair of input connectors.

For termination at the memory card recorder, set the switch to [ON].

### ⑤ REF VIDEO IN connectors and 75 $\Omega$ termination switch

Input connectors for reference video signals.

Input a reference signal with color burst.

For termination at the memory card recorder, set the switch to [ON].

#### Note:

Video and audio output may be disturbed when the reference video signal is not input, so use a system which inputs the reference video signal.

### ⑥ Remote control connectors

Connect the memory card recorder to an external controller.

### ⑦ ENCODER REMOTE connector

Connect the memory card recorder to an external encoder to adjust video output signal settings from an external component.

### ⑧ ANALOG AUDIO IN connectors

These are the analog audio input connectors.

### ⑨ TIME CODE IN connector

Use to record an external time code onto the cards.

### ⑩ TIME CODE OUT connector

Outputs the playback time code during playback.

Outputs the time code generated by the internal time code generator during recording.

### ⑪ SERIAL DIGITAL COMPONENT AUDIO and VIDEO IN and OUT connectors (optional)

Installing an SDI interface board (optional board AJ-YA755G) in the memory card recorder enables input/output of digital component audio/video signals conforming to the SMPTE259M-C standard.

Video signals containing superimposed information can be output through the SDI OUT 3 connector.

To turn the superimposed information ON or OFF, use the SUPER switch ⑤ on the front panel.

#### Note:

The digital audio signals must be synchronized with the video input signals; otherwise noise will be generated in the audio output signals.



# Control reference guide (continued)

## Rear Panel (2/2)

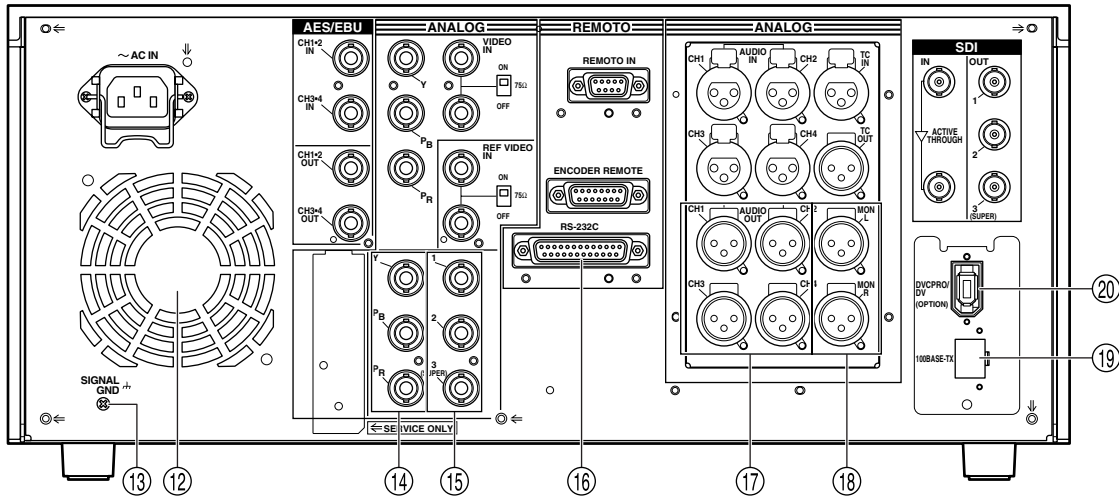

### 12 Fan

Cool the memory card recorder.  
If the fan stops, "E-10" appears on the counter display.

### 13 SIGNAL GND terminal

Connect to the signal ground terminal on the component connected to the memory card recorder to minimize noise. It is not a safety ground.

### 14 ANALOG COMPONENT VIDEO OUT connectors

Output analog component video signals.

### 15 ANALOG COMPOSITE VIDEO OUT connectors

Output analog composite video signals.  
Video signals containing superimposed information can be output through the VIDEO OUT 3 connector.  
Switch ON or OFF with the SUPER switch ⑤ on the front panel.

### 16 RS-232C connector

Connect a personal computer or other component to control the memory card recorder.

### 17 ANALOG AUDIO OUT connectors

Output analog audio signals.

### 18 MONITOR OUT connectors

During playback, a mixed signal is output from the CH1/CH2/CH3/CH4 audio signals. This signal is switched by the MONITOR MIX button ④ on the front panel.

### 19 LAN connectors

Connect to a network with a 100BASE-TX/10BASE-T.

#### Note:

Do not remove the P2 cards while the LAN is connected for use.

### 20 Optional connectors

Installing the optional board (AJ-YAD850G) provides an IEEE1394 interface.

#### Note:

Use shielded cables for all the cables (except for the AC cable) which are to be connected to the rear panel.

Use double-shielded cables for connection to the serial digital signal connectors (DIGITAL AUDIO IN/OUT and SERIAL DIGITAL COMPONENT AUDIO VIDEO IN/OUT connectors).

# Recording and playing

## Inserting P2 cards

### Note:

Before using the unit for the first time, be absolutely sure to set the internal clock using setup menu item No.069 (CLOCK SET).

- (1) Turn the **POWER** switch of the memory card recorder on
- (2) Press a card in a P2 card slot until the **EJECT** button pops out

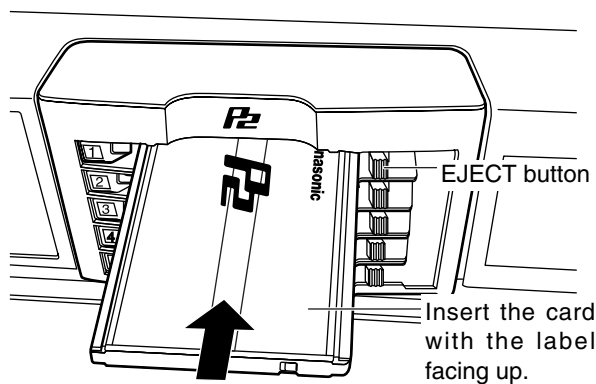

- (3) Push the **EJECT** button that has popped out over to the right

P2 card access LED

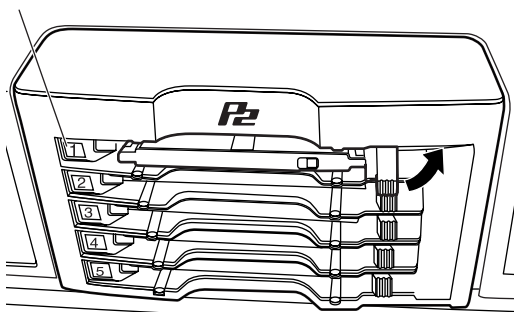

- When the P2 card is inserted into the memory card recorder, its status is indicated by the corresponding P2 card access LED. For details on these statuses, refer to “P2 card access LEDs and P2 card status.”
- When the REC button and PLAY button are pressed together in the stop mode, recording starts on the P2 card corresponding to the access LED which has lighted up orange.

### Notes:

- Even when a second P2 card is inserted into another slot while the data of one card is playing, its access LED will remain off and the other P2 card will not be recognized. The second card will be recognized after the play of the first card has been completed.
- The P2 card access LED will flash and the P2 card will be recognized when a P2 card is inserted into another slot during recording. Do not remove the P2 card while it is being recognized.

## Removing P2 cards

Do not remove a P2 card while it is being accessed or while it is being recognized after it has been inserted (while its corresponding access LED is flashing orange).

- (1) Press the **STOP** button.

If the access LED corresponding to the P2 card you want to remove is flashing orange, press the STOP button to make it stop flashing. If the LED does not stop flashing, hold the STOP button down for over a second.

- (2) Raise the **EJECT** button

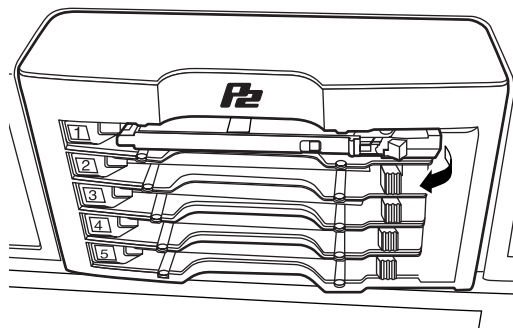

- (3) Push the **EJECT** button in to remove the card

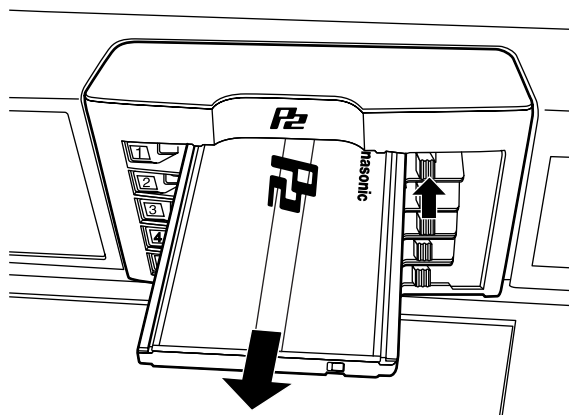

### Notes:

- When a P2 card is removed while the thumbnail screen is displayed, the thumbnail screen is automatically exited.
- Do not remove a P2 card while it is being accessed or while it is being recognized after it has been inserted (while its corresponding access LED is flashing orange). If a P2 card has been removed while it was being accessed, the “TURN POWER OFF” display will appear on the LCD monitor, and the “AUTO OFF” warning will appear on the display panel. Also, all the P2 card access LEDs will flash rapidly in orange. Turn off the power, and then turn it back on.
- The data contained on a P2 card which has been removed while it was being accessed will not be destroyed, but the clips may become irregular. Check the clips first, and then fix them if necessary. (See page 27)
- If a P2 card has been removed while it was being formatted, no guarantees are made for its formatting. Turn on the power, and format the card again.

# Recording and playing (continued)

## Protecting against a possible erasure

Switch the write-protect switch of the P2 card to [PROTECT].

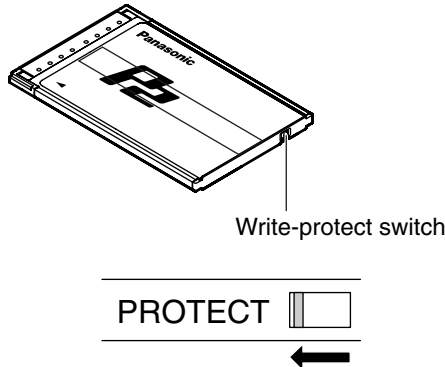

### Notes:

- Any attempt to change the position of the write-protect switch during recording or playback or while the card data is being accessed will have no effect until the recording or playback is completed or the card data is no longer being accessed.
  - When the REC INH switch on the upper front panel is set to [ON], recording onto any of the P2 cards is inhibited, but it is still possible to format, delete clips and set shot marks to ON or OFF.
- When the write-protect switch on the P2 card is set to [PROTECT], all write operations including recording, formatting and clip deletion are inhibited.

## P2 card access LEDs and P2 card status

P2 card access LED	P2 card status
Green lighting	Recording and play are possible.
Orange lighting	Recording and play are possible. The card is selected for recording.
Orange flashing	The memory card recorder is accessing to record or play.
Quick orange flashing	The memory card recorder is reading card information.
Green flashing	The card has no remaining recording capacity (play is possible).
	The write-protect switch is switched to PROTECT (play is possible).
Off	The card is not formatted normally. Format the card again.
	The data format on the card is not standard. Change the card.
	No card is inserted.

### Note:

The statuses of the P2 cards can be verified in detail. Refer to “Contents of P2 Card Status Display Settings” on page 32.

# Connections

## Example of the memory card recorder and DVCPRO VTR

### Source machine:

Set the CONTROL switch on the front panel to [REMOTE] (the memory card recorder : AJ-SPD850).

### Recorder:

Set the CONTROL switch on the front panel to [LOCAL] (VTR : AJ-SD955 or others).

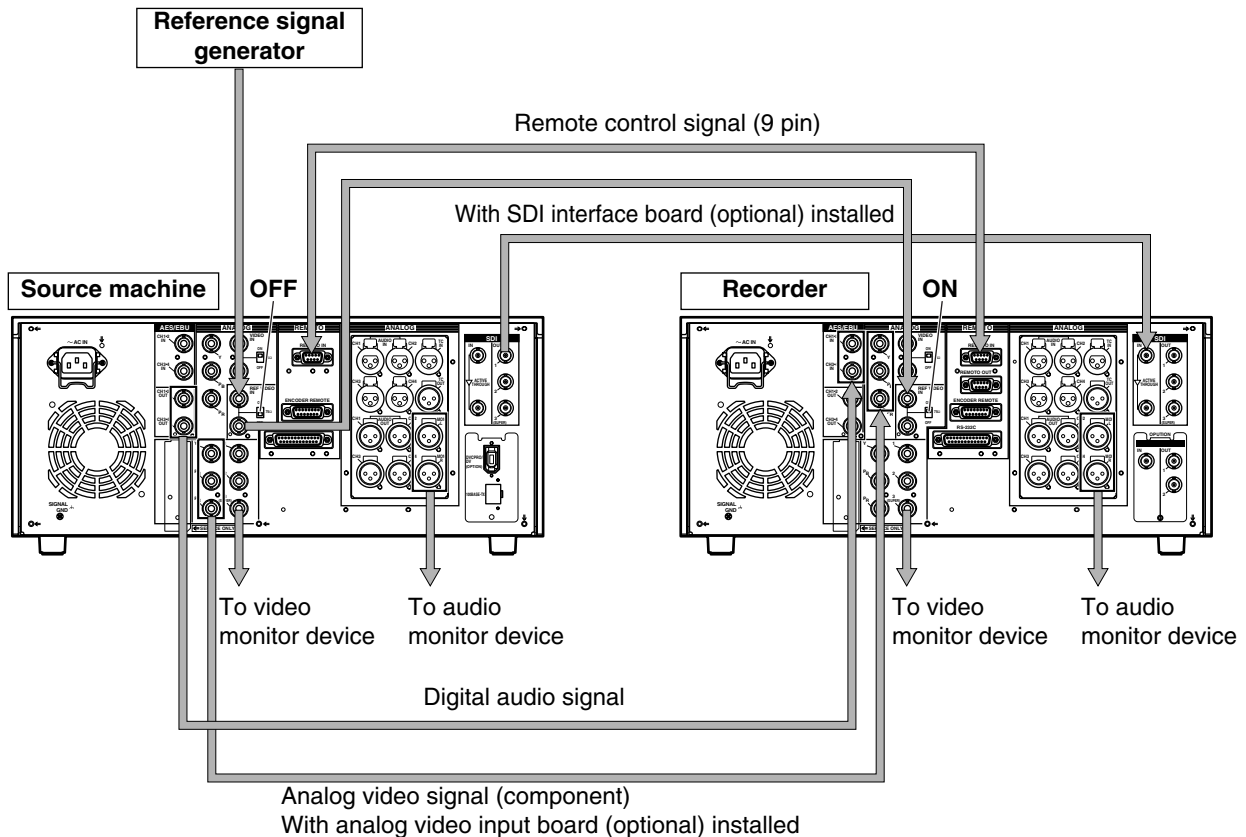

### Notes:

- Video and audio output may be disturbed when the reference video signal is not input, so it is recommended that a system which inputs the reference video signal be used.
- This unit does not come with color framing settings. Perform the settings for editing using "2F."
- In terms of the EE output images (including the V BLANK data), the input images are delayed and then output as is. The menu item settings related to VITC, CC and V BLANK are reflected in the recorded images and playback images but not in the EE output.

## Connection with a PC

1. Connect the USB cable to the USB2.0 connector at the top of the front panel.  
Use a cable that supports USB2.0 (one which is shielded and has a ferrite core) for the USB cable.
2. With the unit now connected to the PC, install the P2 software from the accessory CD-ROM into the PC.  
For further details, refer to the installation manual.

### Notes:

- This unit supports USB2.0 only. It does not support a PC which is compatible with USB1.1.
- Do not remove the P2 cards while the USB is connected for use.
- Except while card data is being accessed, the P2 card access LED remains off while the USB connection is established.
- Use only one deck when making a USB2.0 connection to a PC.

# Jog/Shuttle (Search dial)

---

Locate the edit points.

Each time it is pressed, it is set alternatively to the SHTL/SLOW mode or the JOG mode, and the JOG, SHTL or SLOW lamp lights.

When the power is turned on, the search dial will not operate unless it is first returned to the STILL position.

## Jog mode

**(1) Press the search dial so that it remains pressed in**

Check that the JOG lamp lights.

**(2) Turn the search dial**

The dial's click-stops are released, and the card data is played back at the speed (-1x to +1x) corresponding to the speed at which the dial is turned.

When you stop turning the dial, a still picture is shown.

**(3) To transfer the memory card recorder from the jog mode to another mode, press the button corresponding to the mode**

**Note:**

The factory setting is that when you turn the search dial the mode switches to either shuttle mode or jog mode.

Select KEY at setup menu No. 100 (SEARCH ENA), so the memory card recorder will not transfer to the search mode unless you press the search button.

## Shuttle mode/Slow mode

**(1) Press the search dial so that it is released from the pressed-in position**

The SHTL lamp lights and the shuttle mode is established.

- Immediately after switching the memory card recorder on, turn the search dial and leave it at the center position.

**(2) Press the SHTL/SLOW button and switch to [SHTL] or [SLOW]**

**(3) Turn the search dial**

When the SHTL lamp lights, the playback picture speed changes from 0 up to  $\pm 32x$ , depending on the dial position.

This speed can be switched to  $\pm 8x$ ,  $\pm 16x$ ,  $\pm 32x$ ,  $\pm 60x$  or  $\pm 100x$  at setup menu No. 101 (SHTL MAX).

The dial has a click-stop at the center position where the still picture mode is established.

**(4) To transfer the memory card recorder from the shuttle mode to another mode, press the STOP button or another button**

**Notes:**

- The playback audio is audible in the -10 to +10x speed range from the audio monitor output.
- The playback audio heard in the search mode contains noise.
- When playing a clip that spans a multiple number of P2 cards at a speed faster than  $\pm 1x$ , the sound heard during play may break up now and then: this is normal and not indicative of a malfunction.
- When playing back at the -10x speed, the playback sound may break up: this is normal and not indicative of a malfunction.

# Working with clip thumbnails

A clip is a piece of data containing video and audio from a single video recording, as well as additional information such as voice memos and meta-data.

This unit allows the following operations to be performed using the search dial, FF button, REW button, SHIFT button and SET button while you are checking out the thumbnails of clips displayed on the LCD monitor.

- Playing, deleting, and repairing clips
- Adding/removing shot marks to/from clip thumbnails
- Playing and deleting voice memos
- Formatting P2 cards
- Displaying clip properties and P2 card status

## Overview of thumbnail operations

The thumbnail screen is organized as shown below.

## Notes:

- While the thumbnail screen is displayed, the superimposing is not output even if the SUPER switch has been set to ON.
- The thumbnail screen is output from all the VIDEO OUT and SDI OUT (optional) connectors in accordance with the setup menu No.902 (GUI OUTPUT) setting.



THUMBNAIL



- ALL CLIP
- SELECTED CLIPS
- MARKED CLIPS
- VOICE MEMO CLIPS



- SLOT CLIPS
- SETUP
- EXIT

- MARKED IND.
- VOICEMEMO IND.
- WIDE IND.
- PROXY IND.
- DATA DISPLAY
- DATE FORMAT
- THUMBNAIL SIZE
- THUMBNAIL INIT
- EXIT

OPERATION



- DELETE
- FORMAT
- REPAIR CLIP
- RE-CONNECTION
- DVD (optional)
- DEVICE SETUP
- EXIT

- META DATA
- NETWORK
- DVD (optional)
- EXIT

PROPERTY



CLIP PROPERTY



CARD STATUS

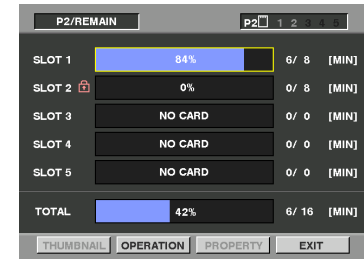

DEVICES

- SD CARD
- LAN
- META DATA
- DVD (optional)
- EXIT

- PROPERTY SETUP
- EXIT



# Working with clip thumbnails (continued)

## Thumbnail screen

Press the THUMBNAIL button to display the thumbnail screen on the LCD. Press the THUMBNAIL button again to return to the normal display.

Press the MENU BAR button on the thumbnail screen to change the pointer to a menu bar. In this state, menu actions can be performed on thumbnails.

## Thumbnail selection operations

Multiple thumbnails can be selected as desired on the thumbnail screen.

### (1) Use the search dial to move the pointer (yellow box) to the clip you want to select, and then press the SET button.

#### Notes:

- Turn the search dial clockwise (or press the FF button) to move the pointer to the right and turn it counterclockwise (or press the REW button) to move the pointer to the left. Similarly, turn it clockwise while holding down the SHIFT button to move the pointer downward, and turn it counterclockwise while holding down the SHIFT button to move the pointer upward.
- The pointer moves to the first or last clip when the REW or FF button is pressed while holding down the SHIFT button.
- A green box appears around the selected clip thumbnail. Press the SET button again to deselect the thumbnail.
- If, after one clip has been selected, the pointer is moved to another clip and then the SET button is pressed while holding down the SHIFT button, all the clips from the clip selected last to the clip where the pointer is currently positioned are selected together.

### (2) To select more clips, repeat step (1).

When the STOP button is pressed while holding down the SHIFT button, all the selected clips are released together.

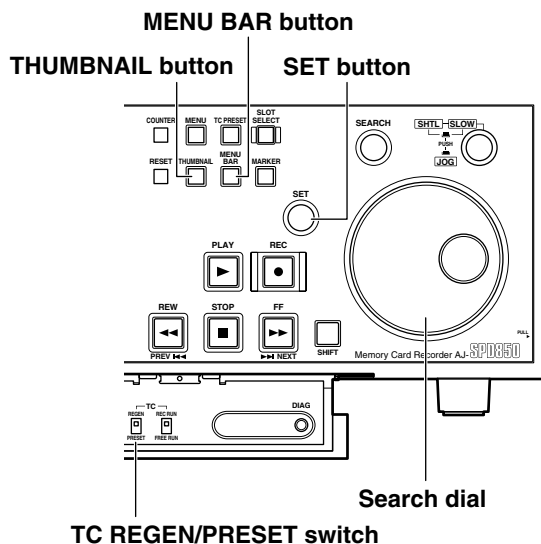

#### Notes:

- Thumbnails operations are not available during time code or user's bit settings when the TC REGEN/PRESET switch is set to PRESET, or during the access to the setup menu.
- The time taken to display the thumbnails differs depending on the number of clips recorded on the P2 card. "UPDATING" is displayed on the thumbnail screen until the thumbnails are displayed.



Thumbnail screen

### ① Display status

The display status indicates the type of thumbnails displayed on the screen.

- ALL** :All clips are displayed.
- SELECTED** :Clips selected by the user are displayed.
- MARKED** :Clips with shot marks are displayed.
- VOICE MEMO** :Clips containing voice memo data are displayed.

**SLOT** :Clips on a specific P2 card are displayed. For details, see "Switching the thumbnail display" on page 25.

### ② Slot number

The slot number indicates which P2 card contains the clip at the pointer location. The slot number of the P2 card containing the clip recording is displayed in yellow. If a clip recording is spread across multiple P2 cards, the slot numbers of all of the P2 cards containing part of the clip recording are displayed.

In addition, the slot number of the slot where the P2 card is inserted is displayed in white.

### ③ Clip number

Numbers set by the memory card recorder are assigned to all clips on the P2 card. The numbers are assigned in chronological sequence, starting with the earliest recording. Clip numbers for clips with different recording formats or other clips that cannot be played by the memory card recorder are displayed in red.

### ④ Thumbnail

The first frame in each recorded clip is displayed as a thumbnail.

### ⑤ Time display

The time display varies depending on the display settings. It shows the time code at the start of a clip recording, the recording time, or the recording date.

For details, see "Thumbnail display settings" on page 28. By default, the time code at the start of a clip recording is displayed.

## Working with clip thumbnails (continued)

### ⑥ Menu bar

The menu bar contains menu items for performing clip operations, switching/setting the thumbnail display, etc. To use the menu bar, press the MENU BAR button on the thumbnail screen. Menu items are selected with the search dial, FF button, REW button or SET button.

**THUMBNAIL** :This menu is used to switch the thumbnail display or set the display method.

**OPERATION** :This menu is used to delete clips and format P2 cards.

**PROPERTY** :This menu is used to display clip properties and P2 card statuses.

**EXIT** :This menu is used to return the pointer to the thumbnail area.

Instead of pressing EXIT, the STOP button can be pressed while holding down the SHIFT button to return the pointer to the thumbnail.

### ⑦ **I** Incomplete clip indicator

Regardless of whether a recording extends over a multiple number of P2 cards, this appears when none of these P2 cards are inserted into the P2 card slots.

### ⑧ **V** Voice memo indicator

This marker is displayed on clips containing a voice memo. For details, see "Voice memos" on page 26.

### ⑨ **M** Shot mark indicator

This marker is displayed on clips in which a shot mark has been added to the thumbnail. For details, on shot marks see "Shot marks" on page 25.

### ⑩ **W** Wide indicator

This marker is displayed on clips recorded with a 16:9 aspect ratio.

### ⑪ **X** Bad clip indicator

This marker is displayed on clips which were improperly recorded because, for example, the power was cut off during recording. It may be possible to repair clips for which the yellow bad clip indicators were displayed. For details, see "Repairing clips" on page 27. Clips which contain red bad clip indicators cannot be repaired, so they should be deleted. If a clip cannot be deleted, format the P2 card. **?** appears instead of **X** when the clips have different formats, etc.

### ⑫ **E** Edit copy clip indicator

This marker is displayed on edit-copied clips.

### ⑬ **P** Indicator for clips with proxy

This marker is displayed for clips with proxy attached.

## ■ Playing clips

### (1) Press the THUMBNAIL button.

The thumbnail screen is displayed on the LCD.

### (2) Use the search dial to move the pointer to the clip you want to play.

The pointer can also be moved to the left by pressing the REW button and to the right by pressing the FF button.

The pointer moves to the first or last clip when the REW or FF button is pressed while holding down the SHIFT button.

### (3) Press the PLAY button.

The clip at the pointer location is played on the LCD.

After the clip at the cursor location has been played, subsequent clips are played in the order in which they were recorded. After the last clip has been played, the thumbnail screen is displayed again.

It is possible to display and play only the selected clips on the thumbnail screen. (It is also possible to select only those clips which satisfy specific conditions, as the clips to be displayed on the thumbnail screen.) For details, see "Switching the thumbnail display" on page 25.

### Notes:

- Clips with clip numbers displayed in red cannot be played.
- It is not necessary to select a clip (so that its thumbnail has a green box around it) in order to play clips.
- If the REW button is pressed while a clip is being played, the clip is played in reverse. If the FF button is pressed, the clip is played in fast forward mode.
- If the STOP button is pressed while a clip is being played, playback is stopped and the thumbnail screen is displayed again.
- While playback is stopped, the pointer remains on the thumbnail of the clip which was being played, regardless of where the pointer was located at the start of playback.
- The images and sound will be disrupted during playback between clips that have different formats (DVCPRO50, DVCPRO, DV): This is normal and not indicative of malfunctioning.

If the THUMBNAIL button is pressed to close the thumbnail screen, the playback start position will change back to the clip with the oldest recording time (Clip number 1).



# Working with clip thumbnails (continued)

## Switching the thumbnail display

It is possible to switch the thumbnail screen so that only clips meeting certain conditions are displayed.

### (1) Press the THUMBNAIL button.

The thumbnail screen is displayed on the LCD.

### (2) Press the MENU BAR button.

The pointer moves to the menu bar.

#### MENU BAR button

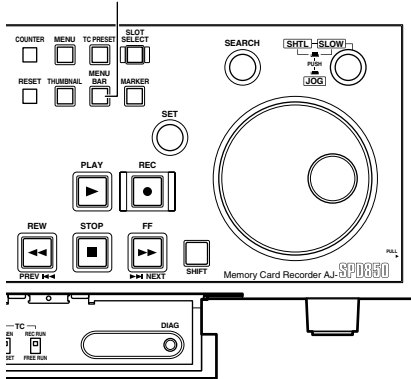

### (3) Move the pointer to THUMBNAIL, and then press the SET button to select it.

A submenu is displayed. Select one of the submenu options to switch the thumbnail display.



#### ALL CLIP:

All clips are displayed.

#### SELECTED CLIPS:

Clips selected by the user are displayed.

#### MARKED CLIPS:

Clips with shot marks are displayed.

#### VOICE MEMO CLIPS:

Clips containing voice memo data are displayed.

#### SLOT CLIPS:

Clips recorded on a P2 card inserted in a specific slot are displayed. When this option is selected, another submenu is displayed, presenting SLOT1 through SLOT5. Select the slot you want to display.

#### SETUP:

For details on this option, see "Thumbnail display settings" on page 28.

#### EXIT:

Exits the submenu.

## Shot marks

The memory card recorder allows the user to add shot marks to clip thumbnails in order to distinguish clips from each other.

#### Note:

Shot marks can even be added during recording.

### (1) Press the THUMBNAIL button.

The thumbnail screen is displayed on the LCD.

### (2) Use the search dial, FF button or REW button to move the pointer to the clip where the shot mark is to be added.

### (3) Press the MARKER button.

#### MARKER button

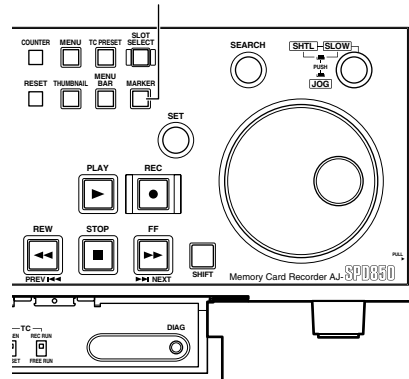

A shot mark is added to the clip thumbnail at the pointer location.

To delete a shot mark, move the pointer to the clip and press the MARKER button again.

#### Notes:

- Before adding a shot mark to a clip that spans a multiple number of P2 cards or deleting a shot mark from such a clip, make sure that all the P2 clips containing the recording of the clip are inserted, and then proceed.
- It takes time to add or delete shot marks to edit-copied clips.

# Working with clip thumbnails (continued)

## ■ Voice memos

A voice memo is audio data which is separate from the original recorded audio and can be added to a clip independently of the original recorded audio. Voice memos added using a camera recorder can be played.

### Note:

Voice memos cannot be added using this memory card recorder.

## Playing voice memos

### (1) Press the THUMBNAIL button.

The thumbnail screen is displayed on the LCD.

### (2) Press the MENU BAR button.

The pointer moves to the menu bar.

### (3) On the menu bar, select [THUMBNAIL], then select [VOICE MEMO CLIPS].

Clip thumbnails containing voice memos will be displayed in the top part of the LCD screen. Information about the voice memo on the clip selected by the pointer will be displayed in the bottom part of the LCD screen.



Thumbnail display area

Still images associated with voice memos are displayed here.

The total number of voice memos added to the clip is indicated here.

### (4) Move the pointer to the clip containing the voice memo you want to play, and then press the SET button.

The pointer moves to the lower part of the LCD screen.



The pointer moves.

### (5) Use the search dial to move the pointer to the still image associated with the voice memo you want to play, and then press the SET button.

The voice memo is played.

While playing voice memos, refrain from performing any operation except STOP.

Press the STOP button to stop a voice memo during playback.

### Note:

The voice memo audio playback is output to the HEADPHONES jack and to the monitor output jack. It is also output through the AUDIO OUT jack.

## Deleting voice memos

### (1) Perform steps (1) through (4) of "Playing voice memos" to select a voice memo on a clip.

### (2) Move the cursor to the voice memo you want to delete, and then press the MENU BAR button.

The pointer moves to the menu bar.

### (3) On the menu bar, select [OPERATION], then [DELETE].

A YES/NO dialog box is displayed.

### (4) Use the search dial and SET button to select YES.

The voice memo is deleted.

## ■ Deleting clips

### (1) Press the THUMBNAIL button.

The thumbnail screen is displayed on the LCD.

### (2) Use the search dial, FF button or REW button to move the pointer to the clip which is to be deleted.

### (3) Press the SET button to select the clip.

### (4) Press the MENU BAR button. On the menu bar, select [OPERATION], then [DELETE].

The following screen is displayed. The number of clips to be deleted at this time appears on the screen.



### (5) Use the search dial and SET button to select YES.

The clip or clips are deleted. All selected clips (enclosed in green boxes) are deleted.

[NOW DELETING...] and the progress are displayed while the clip or clips are being deleted.

Instead of performing the operations in steps (4), clips can also be deleted by pressing the INSERT/DELETE button while holding down the SHIFT button.

# Working with clip thumbnails (continued)

## ■ Repairing clips

This section describes how to repair bad clips which were have been damaged for reasons such as a sudden power outage during recording.

### Note:

Only clips with yellow bad clip indicators can be repaired. Clips with red bad clip indicators should be deleted. If these clips cannot be deleted, the P2 card should be formatted.

### (1) Press the THUMBNAIL button.

The thumbnail screen is displayed on the LCD.

### (2) Use the search dial to move the pointer to the clip you want to repair (if a clip is bad, it has a bad clip mark on it).

### (3) Press the SET button to select the clip.

### (4) Press the MENU BAR button. On the menu bar, select [OPERATION], then [REPAIR CLIP].

A YES/NO dialog box is displayed.

### (5) Use the search dial and SET button to select YES.

## ■ Reconnecting incomplete clips

Incomplete clips may result when the individual segments of a clip recorded across multiple P2 cards (connected clip) are copied separately for each card, etc. These incomplete clips can be reconnected into a single clip (the original connected clip) using the reconnection function.

### (1) Press the THUMBNAIL button.

The thumbnail screen is displayed on the LCD.

### (2) Use the search dial and SET button to select the incomplete clips to be reconnected.

Normally the thumbnails with incomplete clip marks are displayed in succession.

### (3) Press the MENU BAR button. On the menu bar, select [OPERATION], then [RE-CONNECTION].

A YES/NO dialog box is displayed.

### (4) Use the search dial and SET button to select YES.

### Note:

Even when only some of the clips are reconnected, the incomplete clip marks remain unless all of the clips comprising the original clip are reconnected.

## ■ Formatting a P2 card

### (1) Press the THUMBNAIL button.

The thumbnail screen is displayed on the LCD.

### (2) Press the MENU BAR button.

The pointer moves to the menu bar.

### (3) On the menu bar, select [OPERATION], then [FORMAT].

The following screen is displayed.



### (4) Select the slot containing the P2 card you want to format.

The screen shown below is displayed.

If you do not want to format the P2 card, select NO.



### (5) Use the search dial and SET button to select YES.

The selected P2 card will now be formatted.

## ■ Formatting an SD memory card

An SD memory card can be formatted by first inserting the card, following the same procedure as for formatting P2 cards above, and selecting SD CARD in step (4).

### <Cautions in using SD memory cards>

SD memory cards used with the AJ-SPD850 should conform to SD standards. Be sure to format cards using the AJ-SPD850. Cards formatted according to SD standards using PCs or other devices can be used. SD memory cards with the following capacity (8MB - 2GB) can be used for the AJ-SPD850:

8 MB	16 MB	32 MB	64 MB
128 MB	256 MB	512 MB	1 GB
2 GB			

# Working with clip thumbnails (continued)

## Thumbnail display settings

Thumbnail display options can be customized as suitable for the intended use.

### (1) Press the THUMBNAIL button.

The thumbnail screen is displayed on the LCD.

### (2) Press the MENU BAR button.

The pointer moves to the menu bar.

### (3) On the menu bar, select [THUMBNAIL], then [SETUP].

The following screen is displayed.

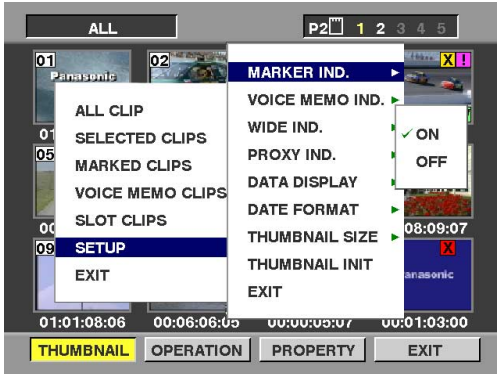

#### MARKER IND.:

Toggles the shot mark indicator display ON/OFF. The default setting is display ON.

#### VOICE MEMO IND.:

Toggles the voice memo indicator display ON/OFF. The default setting is display ON.

#### WIDE IND.:

Toggles the wide indicator display ON/OFF. The default setting is display ON.

#### PROXY IND.:

Switches the proxy indicator between indication and no indication (ON/OFF). The factory setting is ON (indication).

#### DATA DISPLAY:

The following clip time display options are available: time code (TC), user's bit (UB), recording time (TIME), recording date (DATE) or date/time (DATE TIME). The default setting is time code.

#### DATE FORMAT:

The following recording date and time display formats are available: year month day (YMD), month day year (MDY), day month year (DMY). The default setting is year month day (YMD).

This setting applies to the recording date displayed under clip properties, and the recording date and time displayed when DATE is selected for DATA DISPLAY.

#### THUMBNAIL SIZE:

Either LARGE or NORMAL can be selected for the size of the thumbnails which are to be displayed on the LCD monitor screen. The factory setting is NORMAL.

#### THUMBNAIL INIT:

Return the above thumbnail display settings to default. Select [THUMBNAIL INIT], and press the SET button. Select "YES" when the confirmation screen is displayed.

#### EXIT:

Returns to the previous menu.

## Setting of Clip Meta Data

Information such as the name of person who shot the video, the name of the reporter, the shooting location, or a text memo can be read from the SD memory card, and can be recorded as Clip Meta Data.

### <Reading Clip Meta Data (metadata upload)>

#### (1) Insert the SD memory card that contains the Clip Meta Data (metadata upload file).

#### (2) Press the THUMBNAIL button.

The thumbnail screen appears on the LCD monitor.

#### (3) Press the MENU BAR button.

The cursor moves to the menu bar.

#### (4) Select [OPERATION] → [DEVICE SETUP] → [META DATA] → [LOAD] from the menu bar, and press the SET button.



#### (5) Names of metadata upload files stored on the SD memory card are displayed.

Select the desired files using the cursor buttons, and choose YES. Upload starts.

To check the loaded data, refer to "Confirmation of Metadata Upload" on page 33.

### <To set whether or not the uploaded metadata is recorded>

Set ON/OFF by selecting [OPERATION] → [DEVICE SETUP] → [META DATA] → [RECORD] from the menu bar.

#### ON:

The metadata is recorded in accordance with the setting for the USER CLIP NAME recording method.

#### OFF:

The metadata is not recorded.

## Metadata upload files

Using the latest update version of P2 viewer, metadata upload files can be written to SD memory cards using a PC. Download the latest update version of P2 viewer from the following URL and install it to your PC:

<http://panasonic.biz/sav/p2>

Regarding SD memory cards to be used, see "Cautions in using SD memory cards" (page 27).



# Working with clip thumbnails (continued)

## <Selecting the USER CLIP NAME recording method>

From the menu bar, select [OPERATION] → [DEVICE SETUP] → [META DATA] → [USER CLIP NAME] item. Either [TYPE1] or [TYPE2] can be selected as the USER CLIP NAME recording method.

### [TYPE1]

	USER CLIP NAME to be recorded
When clip metadata has been loaded	Uploaded data
When clip metadata has not been loaded or a setting for not recording the loaded clip metadata has been selected	Same as GLOBAL CLIP ID (UMID data)

### [TYPE2]

	USER CLIP NAME to be recorded
When clip metadata has been loaded	Uploaded data + COUNT value <sup>※1</sup>
When clip metadata has not been loaded or a setting for not recording the loaded clip metadata has been selected	Same as CLIP NAME

※1 Concerning the COUNT value

The COUNT value is indicated as a 4-digit number. When the clip metadata has been loaded and [TYPE2] has been selected as the recording method, the COUNT value is incremented by 1 each time a shot is taken and a new clip is generated.

It can be reset by following the sequence of steps below. From the menu bar, select [PROPERTY] → [DEVICE] → [META DATA] and then the [USER CLIP NAME] item. The window shown below now appears. Align the pointer with [COUNT RESET] and press the SET button to reset the COUNT value to 1.

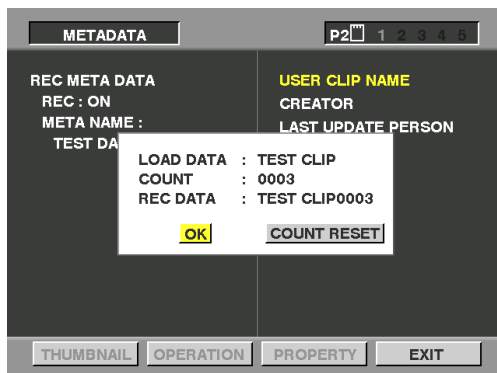

## ● Concerning the incrementing of the COUNT value of USER CLIP NAME with clips exceeding 4 GB

When a P2 card with a memory capacity of 8 GB or more is used in this unit, if a one-time continuous recording exceeds the prescribed duration (refer to the section on “Dividing clips over 4 GB in length” on page 9) or if a one-time recording extends over more than one card, the recording concerned will automatically be undertaken as a separate clip. At this time, the COUNT value is automatically incremented by 1 and recorded.

Example of recording (DVCPRO50) a clip on one P2 card:

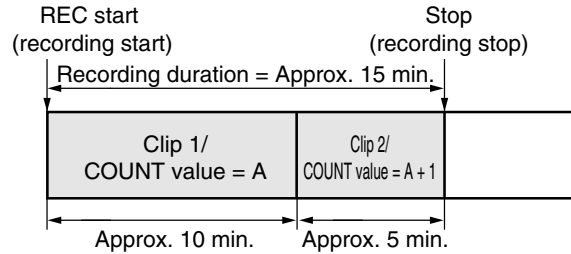

Example of recording a clip on two P2 cards:

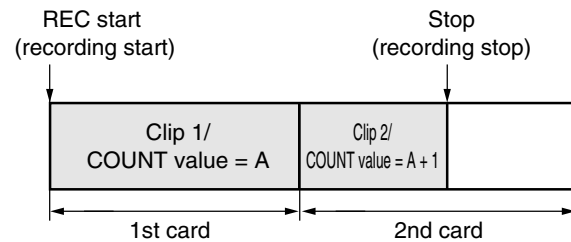

If the clip thumbnails are shown and their properties are displayed using a P2 series product, the thumbnail and COUNT value of clip 1 will be displayed.

## <Clear the uploaded metadata>

Select [OPERATION] → [DEVICE SETUP] → [META DATA] → [INITIALIZE] from the menu bar, and press the SET button. Select “YES” when the confirmation screen is displayed.

# Working with clip thumbnails (continued)

## Network settings

Perform the network settings.

### (1) Press the THUMBNAIL button.

The thumbnail screen is displayed on the LCD.

### (2) Press the MENU BAR button, and select the following from the menu bar: [OPERATION] → [DEVICE SETUP] → [NETWORK] → [MANUAL]. Then select [IP ADDRESS] → [DHCP ON]/[DHCP OFF].

If [DHCP OFF] is selected, set IP ADDRESS, SUBNETMASK and DEFAULT GATEWAY.

### (3) Next set [LOCALHOST NAME] and [USER].

### (4) Set whether [FTP] is to be used and [SAMBA].

Enter the settings using the search dial and SET button.

Shown below is the device setup configuration.

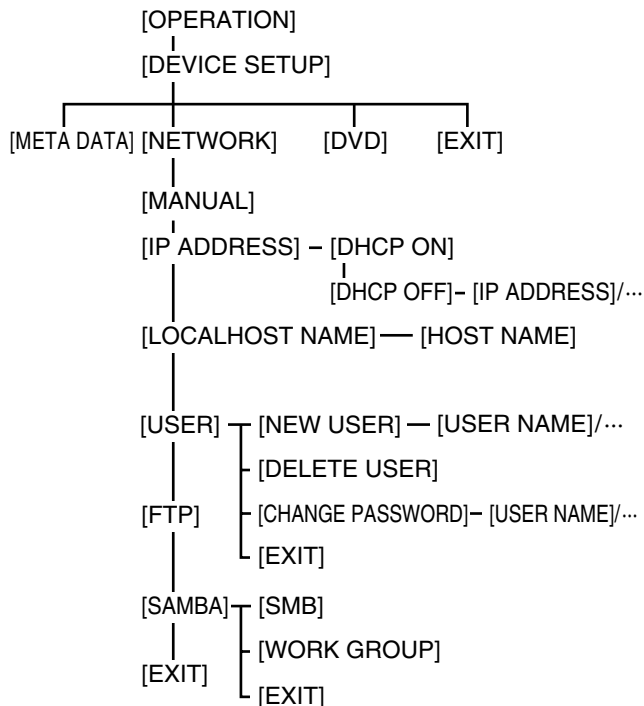

## Notes:

- Data cannot be recorded on the P2 card via the network.
- As a setting for [LOCALHOST NAME] or [USER NAME], a letter of the alphabet must always be used as the first character.  
For [LOCALHOST NAME]:  
Alphanumerics and “-” can be used for the second and subsequent characters.  
For [USER NAME]:  
Alphanumerics, “.” and “\_” can be used for the second and subsequent characters.
- The IP address of [DEFAULT GATEWAY] must be set without fail even when there is no gateway.  
Be absolutely sure to select a value which can be set from the unit's [IP ADDRESS] and [SUBNET MASK].

Example: IP           192.168.000.002  
 MASK            255.255.255.000  
 GATE            192.168.000.xxx\*

\*“xxx” must be a value which does not exist on the network connected.

## DVD settings (optional)

Set whether to use the DVD drive. When not using the DVD drive unit, use the initial setting [DISABLE]. Refer to the operating instructions of the DVD drive unit when using the DVD drive unit.

## Note:

[EXPORT], which is used to save all the clips together in the DVD, cannot be used when a P2 card with a memory capacity of 8 GB or more is used.

## Displaying the properties

This displays the clip properties, P2 card statuses and device properties.



## Displaying the clip properties

From the menu bar, select [PROPERTY], then [CLIP PROPERTY] (alternatively, press the GO TO button while holding down the SHIFT button). The following screen is displayed.



### ① Clip number

### ② Thumbnail

### ③ Clip information

Various indicators added to the clip, and the number of added voice memos are displayed. If the P2 card containing the clip is write-protected, a lock icon is also displayed in this area.

### ④ Slot number

# Working with clip thumbnails (continued)

## ⑤ Clip information

Various clip information is displayed in this area.

**START TC:** The time code value corresponding to the start of recording is displayed here.

**START UB:** The user's bit value corresponding to the start of recording is displayed here.

**TIME:** The time at the start of recording is displayed here.

**DATE:** The recording date is displayed here.

**DURATION:** The clip length is displayed here.

**CODEC:** The clips recording format is displayed here.

## ⑥ Clip meta-data

This area shows more detailed information on the clip. Move the pointer using the search dial, and then press the SET button to display the detailed information.

### GLOBAL CLIP ID:

The global clip ID is displayed here.

### VIDEO:

[FRAME RATE], [PULL DOWN], [ASPECT RATIO] = Information on the video signal system, etc. is displayed here.

### AUDIO:

[SAMPLING RATE], [BITS PER SAMPLE] = Information on the audio channel systems, etc. is displayed here.

### USER CLIP NAME:

The global clip ID is used as is for the USER CLIP NAME if there is no information in the metadata upload file or the [RECORD] item has been set to [OFF].

### ACCESS:

[CREATOR] [CREATION DATE], [LAST UPDATE PERSON] = Information on the date of the last update, etc. is displayed here.

### DEVICE:

[MANUFACTURER], [SERIAL NO.], [MODEL NAME] = Information on the serial number of the device which recorded the data, etc. is displayed here.

### SHOOT:

[SHOOTER], [START DATE], [END DATE], [LOCATION]: Information on the altitude, longitude, latitude, source, place name, recording start date, recording end date, etc. is displayed here.

### SCENARIO \*1/NEWS/MEMO \*2:

[PROGRAM NAME], [SCENE NO.], [TAKE NO.] / [REPORTER], [PURPOSE], [OBJECT] / [PERSON], [TEXT] = Information on the program name, scene number, reporter, subject of the report, etc. is displayed here.

※1 Be sure to enter [PROGRAM NAME] when entering SCENARIO. It is not possible to record only the [SCENE NO.] or [TAKE NO.].

※2 Be sure to enter [TEXT] when entering MEMO. It is not possible to record only [PERSON] or [OFFSET].

The underlined items are automatically added in accordance with the settings when data is recorded by this unit.

Each of these items can be input from a PC, etc. Only ASCII printable characters can be displayed with this memory card recorder.

Although a multiple number of [TEXT] items can be input for one clip, only the first TEXT item is displayed with this memory card recorder.

## ■ P2 Card Status Display Settings

Select [PROPERTY] → [CARD STATUS] from the menu bar to set the desired indication mode (remaining free space or used memory capacity) for the P2 card status display.

### (1) Press the THUMBNAIL button.

The thumbnail screen appears on the LCD monitor.

### (2) Press the MENU BAR button.

The pointer moves to the menu bar.

### (3) From the menu bar, select [PROPERTY] → [PROPERTY SETUP] → [P2 CARD CAP].

The following screen appears. Select the P2 card status display settings from the [P2 CARD CAP] menu option.



### REMAIN:

Show remaining free space on the P2 card as the P2 card status display.

### USED:

Show used memory capacity on the P2 card as the P2 card status display.

# Working with clip thumbnails (continued)

## ■ Contents of P2 Card Status Display Settings

From the menu bar, select [PROPERTY], then [CARD STATUS]. The following screen is displayed.

When REMAIN has been selected

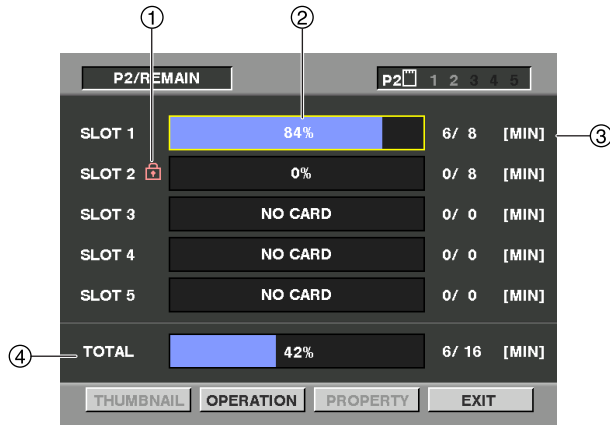

When USED has been selected

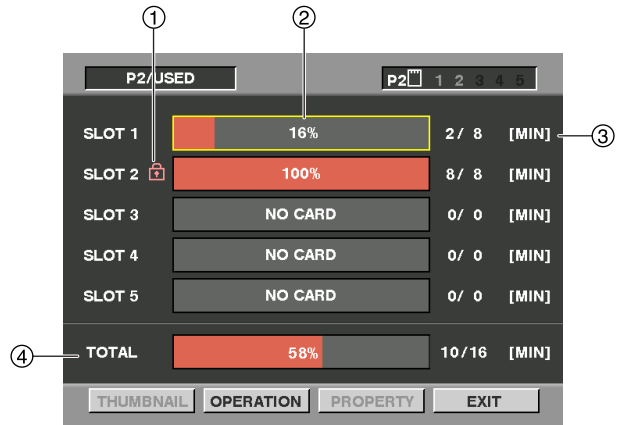

### ① Write protect mark

If the P2 card containing the clip is write-protected, a  mark is displayed here.

### ② P2 card status (remaining free memory)

The free memory remaining on the P2 card is displayed here in the form of a bar meter and a percentage value. As less and less free memory remains, the bar meter decreases toward the left.

One of the following messages may be displayed instead, depending on the card status.

**FORMAT ERROR:** An unformatted P2 card is inserted in the slot.

**NOT SUPPORTED:** A card which is not supported by the memory card recorder is inserted.

**NO CARD:** No P2 card is inserted.

### ③ P2 card remaining memory/total memory

This area shows the P2 card's remaining memory/total memory. The indicated values are given in minute increments. Fractions of a minute are rounded off on the display so that the sum total of the remaining memory available for recording on each P2 card may not tally with the figure for the total memory.

### ④ Slot remaining free memory total

The figure obtained by totaling the remaining free memory of the five slots is shown here.

Note that free space on write-protected P2 cards is not included in the free space total.

### ① Write protect mark

If the P2 card containing the clip is write-protected, a  mark is displayed here.

### ② P2 card status (memory used)

The amount of memory used on the P2 card is displayed here in the form of a bar meter and a percentage value. As more and more memory is used, the bar meter increases toward the right. Depending on the status of the card, one of the following displays may appear.

**FORMAT ERROR:** An unformatted P2 card is inserted in the slot.

**NOT SUPPORTED:** A card which is not supported by the memory card recorder is inserted.

**NO CARD:** No P2 card is inserted.

### ③ P2 card used memory/total memory

The amount of memory used on the P2 cards and their total memory capacities are displayed here. The memory amounts are indicated in minutes. Any amount less than one minute is rounded off so that the total for the amounts of memory used for each of the P2 cards and their total memory capacities may not match. The amount of memory used for a write-protected P2 card is indicated as 100%.

### ④ Total memory used in slots

The figure representing the total memory used by the cards in the five slots is shown here.



# Working with clip thumbnails (continued)

## ■ Displaying the device properties

The statuses of the SD memory card, LAN, metadata and DVD drive can be checked.

### <SD memory card status display>

From the menu bar, select [PROPERTY] → [DEVICES] → [SD CARD].

If the format is compatible with SD standards, the message

**“SD STANDARD: SUPPORTED”**

is displayed.

If the format is not compatible with SD standards, the message

**“SD STANDARD: NOT SUPPORTED”**

is displayed. If this is the case, writing or reading will not be successful. Format the card with the AJ-SPD850. For more on formatting SD memory cards, refer to “Formatting an SD memory card” on page 27.

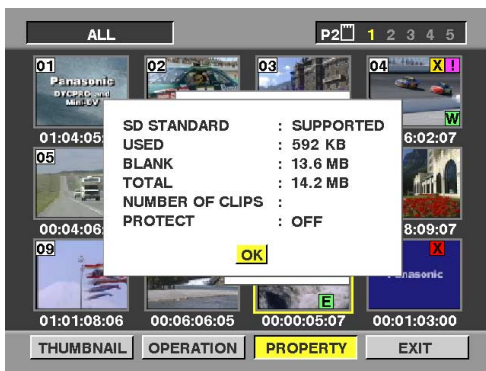

### <LAN status display>

From the menu bar, select [PROPERTY] → [DEVICES] → [LAN] to display the LAN-related settings.

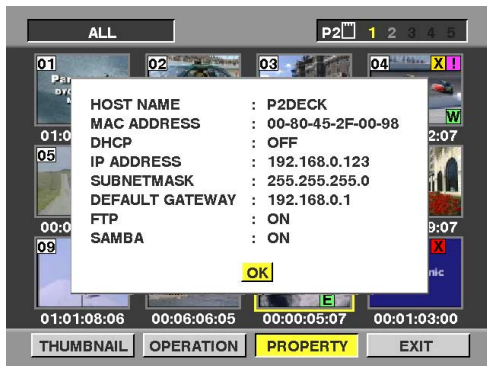

### <Confirmation of Metadata Upload>

The contents of the metadata upload file that is read from the SD memory card can be checked.

From the menu bar, select [PROPERTY] → [DEVICES] → [META DATA]. The following screen appears.

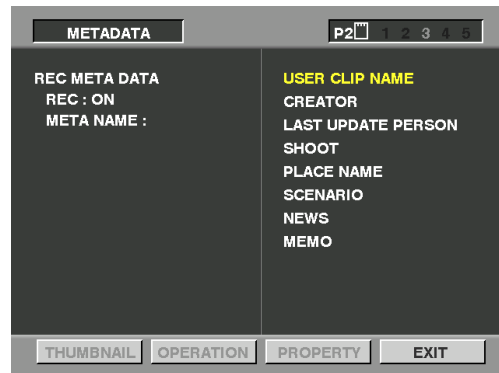

For more information on each item, refer to “Displaying the clip properties” on page 30.

The META NAME is the meta data name written in the meta data upload file, and is not recorded in the clip.

### <DVD status display> (optional)

From the menu bar, select [PROPERTY] → [DEVICES] → [DVD] to display the information on the media inserted in the DVD drive, the operating time of the DVD drive and other information.

#### Note:

Maintenance must be performed when the operating time of the DVD drive has exceeded 2,000 hours. Consult with your dealer.

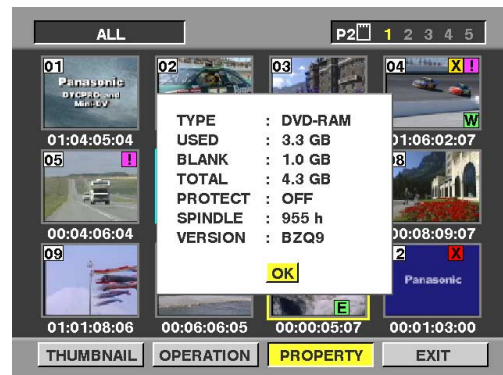

# Play List

The play list function enables only particular parts of the images and sound recorded on five P2 cards to be selected and the selected parts to be played in any order using only the unit by operating the IN, OUT and ENTRY buttons on the front panel.

## Using the play list

### ■ Differences between normal playback and play list playback

#### Normal playback

In the example shown below, clips 1-3 are on P2 card 1, and clips 3-5 are on P2 card 2.

#### Note:

If a recording is split between two P2 cards, the segments are labeled as shown below, where clip 3 is split between clip 3-1 and clip3-2. Playback is continuous from the current position except during play list playback.

The start of the previous (or next) clip is located when the REW (or FF) button is pressed while holding down the SHIFT button, but in the case of a clip which is split between two cards, the start of clip3-2 is also located.

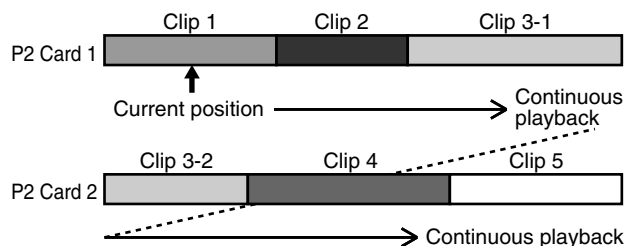

#### Play list playback

Set IN/OUT positions at the locations on the P2 card which are to be played to create a play list. Next, during play list playback, just the required segments are played based on the play list.

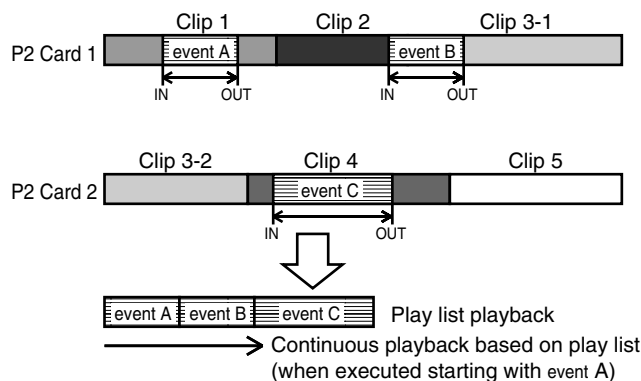

#### Note:

The maximum number of events which can be registered using this unit is 100.

### ■ Switch and submenu selections

#### Play list buttons

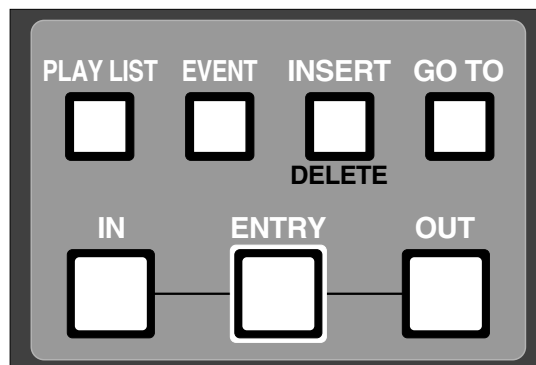

- **PLAYLIST button (self-lighting)**  
This button is used when creating a play list, and to play data based on a created play list. When the button is pressed in the stop mode, a play list is displayed. The button light remains on while a play list is being created or played.
- **EVENT button (self-lighting)**  
When the button is pressed while the PLAYLIST button light is on, the mode changes to play list event (IN/OUT) setting mode. In this mode, the screen shows video output, and the IN/OUT point TC and event number are shown in captions.
- **INSERT button**  
This button is used to add a new event while the play list summary is displayed. Move the pointer to the event you want to insert in the play list display (PLAYLIST button light is on), then press the INSERT button to add the new event.
- **DELETE [SHIFT + INSERT] button**  
This button is used to delete an event while the play list summary is displayed. Move the pointer to the event you want to delete from the play list display (PLAYLIST button light is on), highlight it using the SET button, and delete it by pressing this button.
- **GO TO button**  
This button is used to find the IN and OUT points of individual events registered in the play list. While the play list is displayed (PLAYLIST button light is on), select an event and press the GO TO button while holding down the IN button (or OUT button) to move the IN point (or OUT point). A still image is shown on the screen. Further, when the GO TO button is pressed while holding down the SHIFT button, the selected event can be moved.
- **ENTRY button**  
This button is used to create a play list event. When this button and the IN (or OUT) button are pressed at the same time in play list creation mode (both the PLAYLIST button and EVENT button lights are on), an event IN point (or OUT point) can be set.
- **IN (OUT) button**  
This button is used to create a play list event. When this button and the ENTRY button are pressed at the same time in play list creation mode (both the PLAYLIST button and EVENT button lights are on), an event IN point (or OUT point) can be set. When this button and the RESET button are pressed at the same time, the IN point (or OUT point) of the selected event can be deleted.

# Play List (continued)

## Overview of play list operations

Play lists can be created on the play list screen or event screen. Press the PLAYLIST button to switch to the play list screen or press the EVENT button to switch to the event screen. On the event screen, you can register or change the IN and OUT points while viewing the images. On the play list screen, you can insert and delete events as well as start playing the play lists.

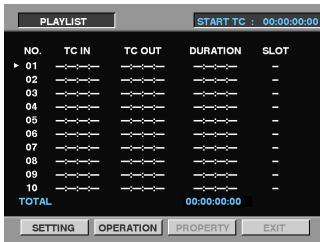

(Play list screen with no events registered yet)

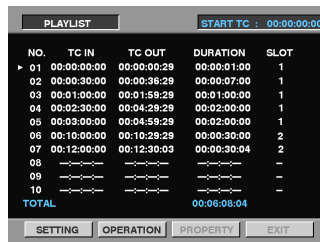

(Play list screen with events already registered)



(Event screen)  
Register or change the IN and OUT points while viewing the images. Set the SUPER switch to ON before proceeding.

The configuration of [SETTING] [OPERATION] on the menu bar is as follows.

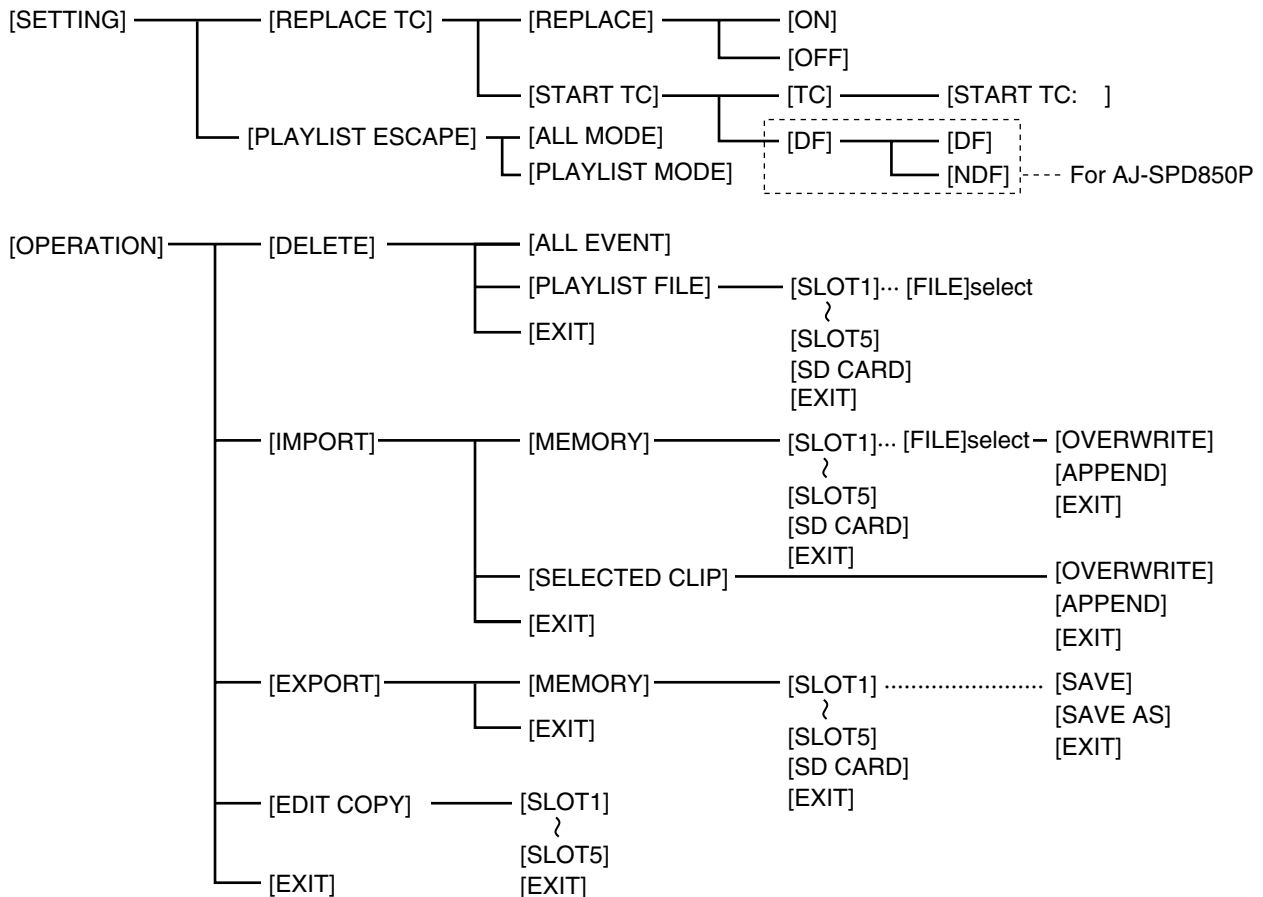

### Notes:

- While the play list screen is displayed, the superimposing is not output even if the SUPER switch has been set to ON.
- The play list screen is output from all the VIDEO OUT and SDI OUT (optional) connectors.

# Play List (continued)

## ■ Creating a play list

### Registering events

(1) Press the **PLAYLIST** button in the stop mode to switch to the play list screen.

(2) Move to the event number corresponding to the event you want to register.

The pointer can be moved faster by turning the search dial while holding down the SHIFT button. When the REW or FF button is pressed at the same time while holding down the SHIFT button, the pointer can be moved to the first event or last event.

(3) Press the **EVENT** button to switch to the event creation screen.

(4) Press the **IN** button and **ENTRY** button at the same time at the position where you want to start the event (PLAY, JOG, SLOW, SHTL, FF, REW, PREV, NEXT, etc.).

(5) Likewise, press the **OUT** button and **ENTRY** button at the same time at the position where you want to end the event (PLAY, JOG, SLOW, SHTL, FF, REW, PREV, NEXT, etc.).

- If the event following the event where the pointer is positioned has not yet been registered, the automatic increment function will increment the event number by one. You may continue with registration if you wish to do so.

- If a registered event applies to multiple clips, the events are registered separately.

### Working with multiple clips (example)

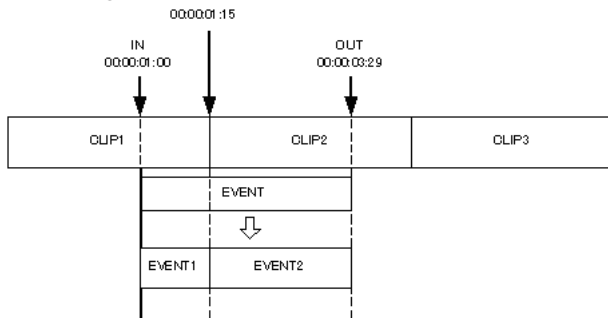

- Also when registering a clip whose recording extends over a multiple number of P2 cards, the clip will be registered as a separate event where it extends over the P2 cards like the above.

- The maximum number of events which can be registered using this unit is 100. Bear in mind that if a multiple number of events are to be registered with a single registration and this number exceeds 100, the events exceeding 100 will not be reflected on the play list.

(6) To check registration or end registration, press the **EVENT** button to return to the play list screen.

- Press the **PLAY** button to start playback at the beginning of the current event. The stop mode is established at an event which has not yet been registered.

### Notes:

- Set the IN and OUT points in such a way that the DURATION of each event is at least 10 frames. Otherwise, the events may not be played properly.
- The images and sound will be disrupted during playback between clips that have different formats (DVCPRO50, DVCPRO, DV): This is normal and not indicative of malfunctioning.

### Flow of operations in creating a play list (registering an event)



PLAYLIST button

PLAYLIST					START TC : 00:00:00:00
NO.	TC IN	TC OUT	DURATION	SLOT	
▶ 01	00:00:00:00	00:00:00:29	00:00:01:00	1	
02	00:00:30:00	00:00:36:29	00:00:07:00	1	
03	00:01:00:00	00:01:59:29	00:01:00:00	1	
04	00:02:30:00	00:04:29:29	00:02:00:00	1	
05	00:03:00:00	00:04:59:29	00:02:00:00	1	
06	00:10:00:00	00:10:29:29	00:00:30:00	2	
07	00:12:00:00	00:12:30:03	00:00:30:04	2	
08	----	----	----	-	
09	----	----	----	-	
10	----	----	----	-	
TOTAL			00:06:08:04		

EVENT button



IN button + ENTRY button  
OUT button + ENTRY button



EVENT button

PLAYLIST					START TC : 00:00:00:00
NO.	TC IN	TC OUT	DURATION	SLOT	
01	00:00:00:00	00:00:00:29	00:00:01:00	1	
02	00:00:30:00	00:00:36:29	00:00:07:00	1	
03	00:01:00:00	00:01:59:29	00:01:00:00	1	
04	00:02:30:00	00:04:29:29	00:02:00:00	1	
05	00:03:00:00	00:04:59:29	00:02:00:00	1	
06	00:10:00:00	00:10:29:29	00:00:30:00	2	
07	00:12:00:00	00:12:30:03	00:00:30:04	2	
▶ 08	00:00:30:00	00:00:30:29	00:00:01:00	1	
09	----	----	----	-	
10	----	----	----	-	
TOTAL			00:06:09:04		

# Play List (continued)

## Changing events

On the play list screen, move the pointer to the number of the event to be changed, and press the EVENT button to switch to the event screen. Play the images, and press the IN or OUT + ENTRY buttons to change the IN or OUT point.

### Notes:

- If the changed IN point comes after an already registered OUT point, the OUT point will be reset. Conversely, if the changed OUT point comes before an already registered IN point, the start TC of the clip concerned will be registered at the IN point.
- If the event following the event where the pointer is positioned has not yet been registered, the pointer will move to the following event.
- Set the IN and OUT points in such a way that the DURATION of each event is at least 10 frames. Otherwise, the events may not be played properly.

## Selecting and releasing events

On the play list screen, move the pointer to the event which is to be selected, and then press the SET button. The display colors of the selected event are reversed. Pressing the SET button again will release the selected event.

If the pointer is moved to another event after selecting an event and then the SET button is pressed while holding down the SHIFT button, all the events from the selected position to the pointer position can be selected together. When the STOP button is pressed while holding down the SHIFT button, all the selected events can be released.

## Adding new events

To add a new event on the play list currently displayed, move the pointer to the event which is shown on the play list (the PLAYLIST button light is on) and which is to be inserted, and press the INSERT button. The new event is now added.

## Deleting events

To delete an event on the play list currently displayed, first move the pointer to the event which is shown on the play list (the PLAYLIST button light is on) and which is to be deleted, and use the SET button to highlight the event. The event can then be deleted by pressing the DELETE [SHIFT + INSERT] button.

## Resetting play lists

All the play list events can be reset. Select [OPERATION] → [DELETE] → [ALL EVENT], and then select [YES]. To cancel the resetting, select [NO] instead. All the events of a play list can be reset also by pressing the RESET button while holding down the SHIFT button.

## Deleting play list files

You can delete play list files. Select [OPERATION] → [DELETE] → [PLAYLIST FILE] to select the location and filename of the file to be deleted, and press the DELETE [SHIFT + INSERT] button.

## Moving events

This button is used to change the sequence of events in the play list. After selecting the event (or events) to be moved, operate the search dial to move the pointer to the place where the event is (or the events are) to be moved. The event is (or the events are) entered by pressing the GO TO button while holding down the SHIFT button. A multiple number of events can also be moved at the same time.

### Moving a play list event

PLAYLIST					START TC : 00:00:00
NO.	TC IN	TC OUT	DURATION	SLOT	
▶ 01	00:00:00:00	00:00:00:29	00:00:01:00	1	
02	00:00:30:00	00:00:36:29	00:00:07:00	1	
03	00:01:00:00	00:01:59:29	00:01:00:00	1	
04	00:02:30:00	00:04:29:29	00:02:00:00	1	
05	00:03:00:00	00:04:59:29	00:02:00:00	1	
06	00:10:00:00	00:10:29:29	00:00:30:00	2	
07	00:12:00:00	00:12:30:03	00:00:30:04	2	
08	---	---	---	-	
09	---	---	---	-	
10	---	---	---	-	
TOTAL			00:06:08:04		

SET button

PLAYLIST					START TC : 00:00:00
NO.	TC IN	TC OUT	DURATION	SLOT	
01	00:00:00:00	00:00:00:29	00:00:01:00	1	
▶ 02	00:00:30:00	00:00:36:29	00:00:07:00	1	
03	00:01:00:00	00:01:59:29	00:01:00:00	1	
04	00:02:30:00	00:04:29:29	00:02:00:00	1	
05	00:03:00:00	00:04:59:29	00:02:00:00	1	
06	00:10:00:00	00:10:29:29	00:00:30:00	2	
07	00:12:00:00	00:12:30:03	00:00:30:04	2	
08	---	---	---	-	
09	---	---	---	-	
10	---	---	---	-	
TOTAL			00:06:08:04		

Search dial

PLAYLIST					START TC : 00:00:00
NO.	TC IN	TC OUT	DURATION	SLOT	
01	00:00:00:00	00:00:00:29	00:00:01:00	1	
02	00:01:00:00	00:01:59:29	00:01:00:00	1	
03	00:02:30:00	00:04:29:29	00:02:00:00	1	
04	00:03:00:00	00:04:59:29	00:02:00:00	1	
05	00:10:00:00	00:10:29:29	00:00:30:00	2	
06	00:12:00:00	00:12:30:03	00:00:30:04	2	
▶ 07	00:00:30:00	00:00:36:29	00:00:07:00	1	
08	---	---	---	-	
09	---	---	---	-	
10	---	---	---	-	
TOTAL			00:06:08:04		

# Play List (continued)

## ■ Importing and storing play lists

### Importing play lists from an external source

(1) Press the **PLAYLIST** button to switch to the play list screen.

(2) Open the **OPERATION** sub menu and select **IMPORT**.

(3) Select the import destination.

#### [SLOT1-SLOT5]:

The play list data stored on any of the P2 cards in slots 1 to 5 is selected.

#### [SD CARD]:

The play list data stored on the SD memory card is selected.

#### [SELECTED CLIPS]:

The clips selected on the thumbnail screen are turned into play list data.

(4) Select the play list data to be imported.

Select the filename.

(5) Select the import method.

#### [OVERWRITE]:

The data overwrites the play list which was set prior to importing.

#### [APPEND]:

The data is added at the bottom of the play list which was set prior to importing.

#### [EXIT]:

Importing is aborted.

(6) Press the **SET** button.

The importing of the play list data starts.

#### Note:

Bear in mind that if the number of events exceeds 100, the play list data for the events exceeding 100 will not be imported.

### Exporting play lists [EXPORT]

• Exporting the data to P2 cards [SLOT1-SLOT5]

The play list data is stored in the designated area on the P2 card in the selected slot.

Select [OPERATION] → [EXPORT] → [MEMORY], and select the slot with the card on which the data is to be stored.

• Storing on SD memory card [SD CARD]

The play list data is stored using the designated format in the designated folder on the SD memory card.

• Storing play list data

#### [SAVE]:

The data overwrites previously stored data under the filename which was imported last. [SAVE] cannot be selected if the file has not been read.

#### [SAVE AS]:

The data is stored under the filename which is automatically appended.

• Use an SD memory card which has been formatted using this unit. (See page 27)

## ■ Playing the play lists

You can start playing a play list from the event where the pointer is positioned by pressing the **PLAY** button while the play list screen is displayed. If the pointer is moved to event 1 and the **PLAY** button is pressed, play list play (playing events which have been registered in succession) starts from the head of the list. To stop the play list play, press the **STOP** button.

During play, it is also possible to set the play TC which will output a continuous value from the prescribed value. In this case, however, the original value will be used as the IEEE1394 or other TC.

The initial value is set and the output TC selected using [SETTING] on the menu bar.

To play the TC from the prescribed value during play:

• Set the TC replacement mode.

Select [SETTING] → [REPLACE TC] → [REPLACE], and set [ON].

• Set the initial TC value.

Input the initial TC value by selecting [SETTING] → [REPLACE TC] → [START TC] → [TC] → [START TC: ].

For AJ-SPD850P:

• Set [DF] or [NDF] for TC.

Select [START TC] → [DF], and then set [DF] or [NDF].

#### Notes:

• Bear in mind that if the event where the pointer is positioned has not been registered, it cannot be played on the play list.

• To play the play list, insert all the P2 cards whose events have been registered on the play list. Otherwise, the play list will not be played properly.

• When any operation other than playback is performed during playback in the TC replacement mode, the TC will be restored to its original value.

• Events registered in a play list are identified by the P2 card serial number, etc. Therefore, clips copied to a different P2 card are not recognized as clips for that play list.

## ■ Play list edit copy function

“Play list edit copying” refers to turning all the events registered in succession from event 1 into a single clip.

(1) Open the **OPERATION** sub menu, and select **EDIT COPY**.

(2) Select the edit copy destination.

#### [SLOT1-SLOT5]:

The edit-copied clips are stored on any of the P2 cards in slots 1 to 5.

(3) Select **YES** using the search dial and **SET** button.

Edit copying now starts.

• If the amount of free memory space on the P2 card serving as the edit copy destination is less than the size of the clip to be edit-copied, “WARNING: LACK OF REC CAPACITY” appears, and edit copy does not commence.

• Edit copying is aborted by pressing the **SET** button or **STOP** button at any point during edit copying.

#### Notes:

• The format of the edit-copied clip is the same as the format of the events prior to edit copying.

• When clips with shot marks added are included in an event, the shot marks will also be added to the edit-copied clips.

• During edit copying, the approximate progress of the operation is indicated.

• When the beginning of an edit-copied clip is searched, the beginnings of the events prior to edit copying are searched.

• During edit copying, information other than the shot mark is not copied.

## Play List (continued)

### ■ Selecting the mode in which to access clips in the normal mode (the mode where the playlist function has been exited)

The method used to access the clips in the normal mode can be changed.

Set this to use the playlist you have created as material for the player in the editing system which employs the RS-422A interface.

- (1) Press the **PLAYLIST** button to switch to the play list screen.
- (2) Open the **SETTING** sub-menu, and select **PLAYLIST ESCAPE**.
- (3) Select the mode to be used to access the clips in the normal mode.

#### [ALL MODE]:

All the clips can be accessed.

#### [PLAYLIST MODE]:

Only those clips registered in the play list mode can be accessed.

- (4) Press the **SET** button, and then press the **PLAYLIST** button.

Operation returns to the normal mode.

#### Notes:

- Although clips can be played in the play list mode while replacing them with a continuous TC value using the [REPLACE TC] setting, the original values will be retained for the TC values played back in the PLAYLIST mode while in the normal mode.
- When [PLAYLIST MODE] is selected as the mode in which to access clips in the normal mode, an asterisk (\*) appears in front of the operation mode on the superimposed display, and the PLAYLIST button on the front panel flashes.
- When the power is turned off, [ALL MODE] is set automatically.
- When [PLAYLIST MODE] is set, the setup menu cannot be opened.

## List of shortcuts

### ■ While thumbnails are displayed

Front panel operation	Description
[SHIFT] + [STOP]	Deselect Cancel operation (return to top)
[SHIFT] + [SET]	Select multiple clips * 1
[SHIFT] + [DELETE]	Delete selected clip(s)
[SHIFT] + [REW]	Jump to first clip
[SHIFT] + [FF]	Jump to last clip
[SHIFT] + [GOTO]	Display clip properties

### ■ While play lists are displayed

Front panel operation	Description
[SHIFT] + [STOP]	Deselect
[SHIFT] + [SET]	Select multiple events * 1
[SHIFT] + [RESET]	Delete entire play list
[SHIFT] + [DELETE]	Delete selected event(s)
[SHIFT] + [REW]	Jump to first event
[SHIFT] + [FF]	Jump to last event
[SHIFT] + [GOTO]	Move play list

- ※1 You can select any of the clips in the following range: from the clip (or event) last selected to the clip (or event) where the cursor is now positioned.



# Setup (Initial settings)

The memory card recorder's main settings are performed while making selections using a system of menus. If a TV monitor has been connected to the VIDEO OUT 3 connector or SDI OUT 3 connector (optional) on the rear panel and the SUPER switch is set to [ON], the setting menus are displayed on the TV monitor.

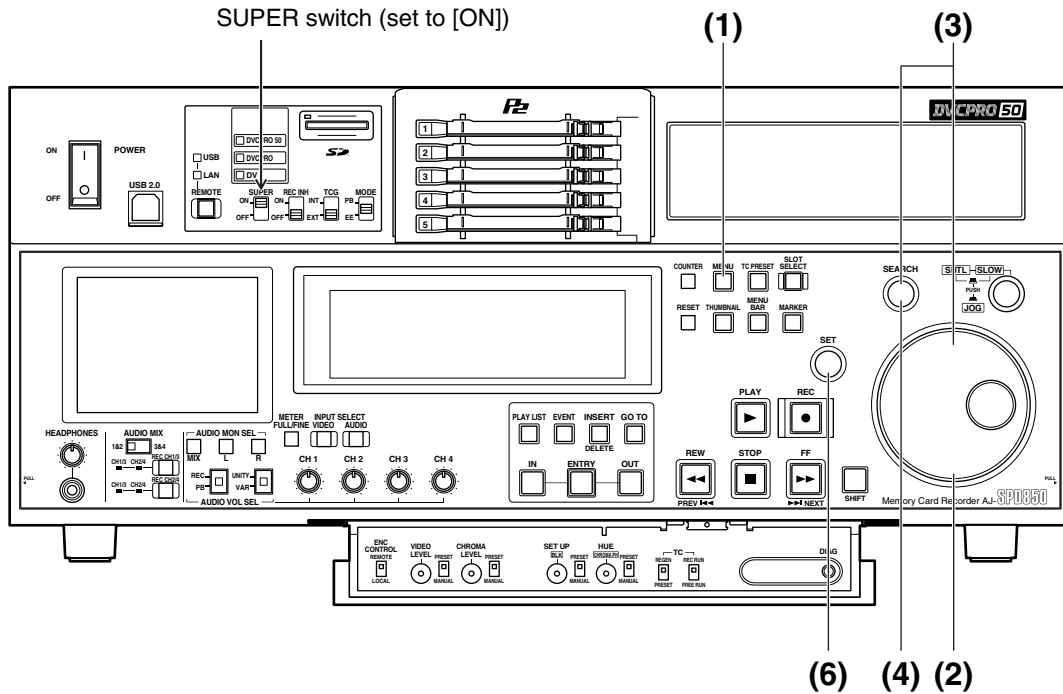

## ■ Changing the settings

### (1) Press the MENU button

The setup menu screen appears on the TV monitor, and the setup menu item number appears on the counter display.

Each time the FF button is pressed (for about 1.5 seconds), the item number and item name are displayed alternately.

(If a setup was performed previously, the screen on which the last change was made is displayed.)

### (2) Turn the search dial to select the item to be set

The menu screen cursor (\*) moves, and the item number on the display flashes.

- When the dial is turned clockwise, the item number is incremented from 001 → 002 → 003 → 004 and so on; conversely, when it is turned counterclockwise, the item number is decremented.

- When the FF button or REW button is pressed while holding down the PLAY button, the next or previous item is selected.

- Whenever possible, limit the use of the search dial to the JOG mode.

### (3) At the position where the change is to be made, turn the search dial while holding down the SEARCH button

The settings on the menu screen and display now flash. When the dial is turned clockwise, the setting number is incremented; conversely, when it is turned counterclockwise, it is decremented.

### (4) Upon completion of the setting, release the SEARCH button

- When the search dial is in the SHTL mode, the item will move unless the dial is set to the center position.

### (5) When other items are to be changed, repeat steps (2) to (4)

### (6) Press the SET button

The changes are stored in the memory.

To disregard the new settings and restore the old settings instead, press the MENU button.

- To return the setup contents to the factory settings (initial settings), press the RESET button while the menu is displayed. The following message is displayed.

```

SETUP - MENU INIT SET
YES<PLAY> / NO<STOP>
    
```

If the PLAY button is now pressed, the factory settings are reinstated.

#### Notes:

- If the RESET button is pressed to restore the factory settings, only the user files currently in use are restored. The other user files remain unaffected.
- The changes made to the SYSTEM menu contents are recorded even by pressing the MENU button to close the menu screen.



# Setup menus

The memory card recorder can hold five user files, each of which has its own specific menu settings, and one of these files can be selected for use.

## ■ Changing the file

- (1) Press the MENU button
- (2) Press the FF button while holding down the DIAG (or SHIFT) button to switch to the next user file or press the REW button while holding down the DIAG (or SHIFT) button to return to the previous user file

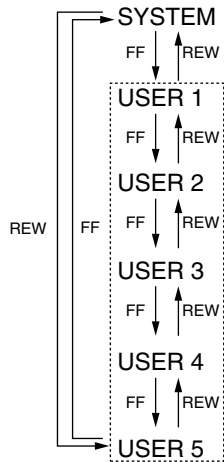

### User files

Each user file contains the following items.

- BASIC
- OPERATION
- INTERFACE
- EDIT
- TIME CODE
- VIDEO
- AUDIO
- V BLANK
- LCD
- MENU

- (3) To enter the selection made in step (2) for the user file which is to be used, press the SET button

The user file is changed and stored in the memory.

### Note:

Since the SYSTEM menu items are not included in user files 1 through 5, first select the user file and switch to the SYSTEM file, and then set the SYSTEM menu items.

## ■ Setting and releasing the lock mode

The lock mode can be set to protect the system file and user file (USER2 to USER5) settings. Once the lock mode is set, no further changes can be made to the settings.

Setting and releasing the lock mode can be set for the system file by using setup menu No. 40 (MENU LOCK) and for the user files by using setup menu No.A03 (MENU LOCK).

- (1) Press the MENU button
- (2) Press the REW or FF button while holding down the DIAG (or SHIFT) button and select the file for which the lock mode is to be set or released

- (3) Turn the search dial

The cursor ( \*) on the menu screen is moved to No. 40 (MENU LOCK) for the system file or to No. A03 (MENU LOCK) for a user file.

- (4) Turn the search dial while holding down the SEARCH button to select whether the lock mode is to be set or released

**To set the lock mode:**

Set 0001 (ON) as the setting.

**To release the lock mode:**

Set 0000 (OFF) as the setting.

When the lock mode has been set, "LOCKED" flashes on the menu screen. The counter display stops flashing and remains lighted.

SETUP-MENU	LOCKED
<USER2>	NO.000-0005
*000 P-ROLL TIME	5s
001 LOCAL ENA	STOP
002 CTL DISP	±12h
003 REMAIN SEL	2L
008 DISPLAY SEL	T&STA
009 CHARA H-POS	4
010 CHARA V-POS	18
011 CHARA TYPE	WHITE
012 SYS FORMAT	50M

- (5) Press the SET button

The setting is stored in the memory.

### Notes:

- The lock mode cannot be set for the USER1 file.
- Once set to the lock mode, a file cannot be reset to the factory settings even by pressing the RESET button.

# Setup menus (continued)

## ■ Loading user files

The contents of the USER2, USER3, USER4 or USER5 file can be copied (loaded) into the USER1 file. Also, the contents of the USER1 file can be copied (saved) into the USER2, USER3, USER4 or USER5 file.

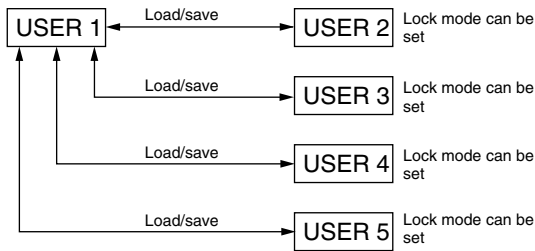

- (1) Press the MENU button
- (2) Press the REW or FF button while holding down the DIAG (or SHIFT) button and select USER1 file
- (3) Turn the search dial to move the cursor (\*) on the menu screen to No. A00 (LOAD)

```

SETUP-MENU  MENU
<USER1>    NO .A00-0000
902 GUI OUTPUT OFF
*A00 LOAD USER2
A01 SAVE USER2
A02 P. ON LOAD OFF
END
    
```

- (4) Turn the search dial while holding down the SEARCH button to select the user file whose contents are to be loaded into USER1
- (5) Press the SET button

The following message appears on the menu screen and counter display.

Menu screen

```

SETUP-MENU  LOAD
USER2 → USER1 OK?
YES<PLAY>/NO<STOP>
    
```

Counter display



The number of the user file selected in step (4) is displayed at ■.

- (6) Press the PLAY button
- (7) Turn the search dial to move the cursor (\*) on the menu screen to a number other than No. A00 (LOAD) or No. A01 (SAVE)
- (8) Press the SET button

The USER1 settings are stored in the memory. If the USER1 settings are not to be stored in the memory, do not press the SET button but press the MENU button instead.

## ■ Saving user files

- (1) Press the MENU button
- (2) Press the REW or FF button while holding down the DIAG (or SHIFT) button and select USER1 file
- (3) Turn the search dial to move the cursor (\*) on the menu screen to No. A01 (SAVE)

```

SETUP-MENU  MENU
<USER1>    NO .A00-0000
902 GUI OUTPUT OFF
A00 LOAD USER2
*A01 SAVE USER2
A02 P. ON LOAD OFF
END
    
```

- (4) Turn the search dial while holding down the SEARCH button to select the user file in which the contents of USER1 are to be saved

Those user files which have been set to the lock mode do not appear on the display. If all the user files have been set to the lock mode, the "LOCKED" display appears, and the contents of USER1 cannot be saved into any of the user files.

- (5) Press the SET button

The following message appears on the menu screen and counter display.

Menu screen

```

SETUP-MENU  SAVE
USER1 → USER2 OK?
YES<PLAY>/NO<STOP>
    
```

Counter display

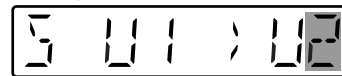

The number of the user file selected in step (4) is displayed at ■.

- (6) Press the PLAY button
  - (7) Turn the search dial to move the cursor (\*) on the menu screen to a number other than No. A00 (LOAD) or No. A01 (SAVE)
  - (8) Press the SET button
- The USER1 settings are stored in the memory. If the USER1 settings are not to be stored in the memory, do not press the SET button but press the MENU button instead.

## ■ Automatically recalling a user file when turning on the power

If the user file to be loaded is selected in advance using setup menu No. A02 (P. ON LOAD), the file will be automatically loaded into USER1 when the power is turned on.



## Setup menus (continued)

### SYSTEM menu

No./Item	Description
30 <b>BRIGHT</b>	<p>This adjusts the brightness of the LCD monitor on the front panel.</p> <p>0000    -7 :        : <u>0007</u>    0 :        : 0014    7</p> <p><b>Note:</b> If setting operation is performed, the setting value does not return to factory (default) setting.</p>
31 <b>CONTRAST</b>	<p>This adjusts the contrast of the LCD monitor on the front panel.</p> <p>0000    -7 :        : <u>0007</u>    0 :        : 0014    7</p> <p><b>Note:</b> If setting operation is performed, the setting value does not return to factory (default) setting.</p>
40 <b>MENU LOCK</b>	<p>This selects whether the system file lock mode is to be engaged or released.</p> <p><u>0000</u> <b>OFF</b> : The lock is released (file data can be changed). 0001 <b>ON</b> : The lock is engaged (file data cannot be changed).</p>

### USER menu <BASIC>

No./Item	Description
000 <b>P-ROLL TIME</b>	<p>This sets the preroll time. The preroll time can be set from 0 to 15 seconds in 1-second increments.</p> <p>0000    0s :        : <u>0005</u>    5s :        : 0015    15s</p>
001 <b>LOCAL ENA</b>	<p>This selects the buttons which can be operated on the front panel when the REMOTE button is lit.</p> <p>0000    <b>DIS</b> : No buttons can be operated. <u>0001</u>    <b>STOP</b> : Only the STOP button can be operated. 0002    <b>ENA</b> : All buttons can be operated.</p>
002 <b>CTL DISP</b>	<p>This selects the 12 or 24 hour display for the CTL counter.</p> <p><u>0000</u>    ±12h : 12 hour display 0001    24h : 24 hour display</p>
003 <b>REMAIN SEL</b>	<p>This selects whether the remaining time or total time is to be displayed in the superimposed display of the VIDEO OUT 3/ SDI OUT 3 connector (optional) signals.</p> <p>0000    <b>OFF</b>: No display. 0001    <b>2L</b> : The remaining time is displayed on the second line. <u>0002</u>    <b>1L</b> : The remaining time is displayed on the first line. 0003    <b>R/TTL</b> : The remaining time is displayed on the first line, and the total time is displayed in the second line.</p> <p><b>Notes:</b></p> <ul style="list-style-type: none"> <li>•When "2L" is selected, the remaining time is not displayed if "TIME" has been selected as the setup menu item No. 008 (DISPLAY SEL) setting.</li> <li>•When "R/TTL" is selected, the total time is not displayed if "TIME" has been selected as the setup menu item No. 008 (DISPLAY SEL) setting.</li> </ul>

The underlined items indicates the initial setting.

# Setup menus (continued)

## ■ USER menu <BASIC>

No./Item	Description
008 DISPLAY SEL	<p>This selects what information is to be provided by the time code and other superimposed displays output from the VIDEO OUT 3/SDI OUT 3 connector (optional).</p> <p><b>0000 TIME :</b> Data only. (The data indicates the value for whichever of CTL, TC or UB currently selected by the COUNTER button.)</p> <p><b>0001 T&amp;STA :</b> Data and operation status.</p> <p><b>0002 T&amp;S&amp;M :</b> Data, operation status and mode.</p> <p><b>0003 T&amp;RT :</b> Data and REC TIME</p> <p><b>0004 T&amp;YMD :</b> Data and REC DATE (year/month/day)</p> <p><b>0005 T&amp;MDY :</b> Data and REC DATE (month/day/year)</p> <p><b>0006 T&amp;DMY :</b> Data and REC DATE (day/month/year)</p> <p><b>0007 T&amp;UB :</b> Data and user bit. However, when UB has been selected with the COUNTER button, the time code is displayed after the user bit.</p> <p><b>0008 T&amp;CTL :</b> Data and CTL data. However, when CTL has been selected with the COUNTER button, the time code is displayed after the CTL data.</p> <p><b>0009 T&amp;T :</b> Data and time code.</p> <p><b>0010 VITC:</b> The time code and user bit recorded on the card are displayed.</p> <p><b>Notes:</b></p> <ul style="list-style-type: none"> <li>•Mode display: DVCPRO 50 (50 Mbps) = DVCPRO_50, DVCPRO (25 Mbps) = DVCPRO, DV = DV</li> <li>•An error message appears if a warning or error has occurred when "T&amp;S&amp;M" has been selected as this setting.</li> <li>•The recording duration and recording time and date are displayed when the DV format applies. The operating status is displayed instead when the DVCPRO50 (50 Mbps) or DVCPRO (25 Mbps) format applies.</li> </ul>

No./Item	Description												
009 CHARA H-POS	<p>This sets the position of the characters on the horizontal plane for the time code and other superimposed displays output from the VIDEO OUT 3/ SDI OUT 3 connector (optional).</p> <p><b>0000 0</b> : <b>0004 4</b> : <b>0016 16</b></p> <p><b>Note:</b> Characters may extend beyond the edges of the screen.</p>												
010 CHARA V-POS	<p>This sets the position of the characters on the vertical plane for the time code and other superimposed displays output from the VIDEO OUT 3/ SDI OUT 3 connector (optional).</p> <table style="width: 100%; border: none;"> <tr> <td style="text-align: center;">[525i system]</td> <td style="text-align: center;">[625i system]</td> </tr> <tr> <td style="text-align: center;"><b>0000 0</b></td> <td style="text-align: center;"><b>0000 0</b></td> </tr> <tr> <td style="text-align: center;">:</td> <td style="text-align: center;">:</td> </tr> <tr> <td style="text-align: center;"><b>0018 18</b></td> <td style="text-align: center;"><b>0023 23</b></td> </tr> <tr> <td style="text-align: center;">:</td> <td style="text-align: center;">:</td> </tr> <tr> <td style="text-align: center;"><b>0022 22</b></td> <td style="text-align: center;"><b>0028 28</b></td> </tr> </table> <p><b>Note:</b> When the DISPLAY SEL setting causes characters to extend beyond the edges of the screen, the setting value is changed so that the characters are automatically displayed in a position on the screen.</p>	[525i system]	[625i system]	<b>0000 0</b>	<b>0000 0</b>	:	:	<b>0018 18</b>	<b>0023 23</b>	:	:	<b>0022 22</b>	<b>0028 28</b>
[525i system]	[625i system]												
<b>0000 0</b>	<b>0000 0</b>												
:	:												
<b>0018 18</b>	<b>0023 23</b>												
:	:												
<b>0022 22</b>	<b>0028 28</b>												
011 CHARA TYPE	<p>This selects the display type for the superimposed display output from the VIDEO OUT 3/SDI OUT 3 connector (optional) as well as for displays such as the setup menu, etc.</p> <p><b>0000 WHITE :</b> White characters against a black background.</p> <p><b>0001 W/OUT :</b> White characters with a black border.</p>												

The underlined items indicates the initial setting.

# Setup menus (continued)

## ■ USER menu <BASIC>

No./Item	Description
012 SYS FORMAT	<p>This sets the memory card recorder's recording and playback format.</p> <p><u>0000</u> <u>50M</u> : DVCPRO50 (50 Mbps) is selected.</p> <p>0001 <u>25M</u> : DVCPRO (25 Mbps) is selected.</p> <p>0002 <u>DV</u> : DV (25 Mbps) is selected.</p> <p><b>Note:</b> The format complies with the setting of this menu item when the card is ejected.</p>
017 CHARA SIZE	<p>This selects the size of the characters for the superimposed display output from the VIDEO OUT 3/SDI OUT 3 connector (optional).</p> <p><u>0000</u> <u>NORMAL</u> : Standard size</p> <p>0001 <u>LARGE</u> : 4 times larger than the standard size</p> <p><b>Note:</b> When LARGE has been selected, only time data is displayed, regardless of the setup menu No.008 (DISPLAY SEL) setting.</p>

No./Item	Description
069 CLOCK SET	<p>Sets the internal clock time.</p> <p><b>Note:</b> Press the STOP button to display a sub-screen for selecting the line to be recorded. Press the STOP button again to return from the sub-screen.</p>
<b>Sub-screen</b>	
00 YEAR	<p>Sets the year.</p> <p><u>0000</u>    <u>2000</u> :        : <u>0004</u>    <u>2004</u> :        : 0030    2030</p>
01 MONTH	<p>Sets the month.</p> <p><u>0001</u>    <u>JAN</u> :        : 0012    <u>DEC</u></p> <p><b>Note:</b> If a nonexistent day is set while setting Feb, April, June, September, or November, it is set as the first day of the following month.</p>
02 DAY	<p>Sets the day.</p> <p><u>0001</u>        <u>1</u> :            : 0031        31</p> <p><b>Note:</b> If a nonexistent day is set while setting Feb, April, June, September, or November, it is set as the first day of the following month.</p>
03 HOUR	<p>Sets the hour value. Set the value based on 24-hour clock time.</p> <p><u>0000</u>        <u>0</u> :            : 0023        23</p>
04 MINUTE	<p>Sets the minute value.</p> <p><u>0000</u>        <u>0</u> :            : 0059        59</p>

The underlined items indicates the initial setting.

# Setup menus (continued)

## ■ USER menu <BASIC>

No./Item	Description
<b>05</b>	<b>Sets the time difference from the world standard time.</b>
<b>TIME ZONE</b>	
<b>0000</b>	<b>00:00</b>
<b>0001</b>	<b>+00:30</b>
<b>0002</b>	<b>+01:00</b>
<b>:</b>	<b>:</b>
<b>0050</b>	<b>-00:30</b>
	Refer to the table below, and select the setting which corresponds to the local time.

Time difference	City/region	Time difference	City/region
00:00	Greenwich	+ 13:00	
- 00:30		+ 10:30	Lord Howe Island
- 01:00	Azores	+ 12:00	New Zealand
- 01:30		+ 09:30	Darwin Islands
- 02:00	Central Atlantic time	+ 11:00	Solomon Islands
- 02:30		+ 08:30	
- 03:00	Buenos Aires	+ 10:00	Guam
- 03:30	Newfoundland	+ 07:30	
- 04:00	Halifax	+ 09:00	Tokyo
- 04:30		+ 06:30	Rangoon
- 05:00	New York	+ 08:00	Beijing
- 05:30		+ 05:30	Bombay
- 06:00	Chicago	+ 07:00	Bangkok
- 06:30		+ 04:30	Kabul
- 07:00	Denver	+ 06:00	Dacca
- 07:30		+ 03:30	Teheran
- 08:00	Los Angeles	+ 05:00	Islamabad
- 08:30		+ 02:30	
- 09:00	Alaska	+ 04:00	Abu Dhabi
- 09:30	Marquesas Islands	+ 01:30	
- 10:00	Hawaii	+ 03:00	Moscow
- 10:30		+ 00:30	
- 11:00	Midway Islands	+ 02:00	Eastern Europe
- 11:30		+ 12:45	Chatham Islands
- 12:00	Kwajalein Atoll	+ 01:00	Central Europe
+ 11:30	Norfolk Islands		

### Note:

The clock has an accuracy equivalent to a monthly error of  $\pm 30$  seconds with the power OFF. When the precise time is required, check the time and reset it while the power is ON.

No./Item	Description
<b>070</b>	<b>This selects the TV system.</b>
<b>TV SYSTEM</b>	
	[525i system]                      [625i system]
<b>0000</b>	<b>525      0000</b>
<b>0001</b>	<b>625      0001</b>
<b>0000:</b>	The 525 interlace/59.94 Hz system is selected.
<b>0001:</b>	The 625 interlace/50 Hz system is selected.
<b>Notes:</b>	
	•After this setting is changed, turn off and back on the power again to take it effect.
	•Analog video signals cannot be selected using INPUT SELECT once the TV system has been changed from the factory setting.
	•When the setting is changed, the play list is reset.



## Setup menus (continued)

### ■ USER menu <OPERATION>

No./Item	Description
100 SEARCH ENA	<p>This selects the direct search dial operation.</p> <p><u>0000</u> <b>DIAL</b> : For direct search dial operations.</p> <p><u>0001</u> <b>KEY</b> : Operation is not transferred to the search mode unless the search button is pressed.</p>
101 SHTL MAX	<p>This sets the maximum speed for shuttle operations.</p> <p><u>0000</u> <b>x8</b> : 8x normal speed  <u>0001</u> <b>x16</b> : 16x normal speed  <u>0002</u> <b>x32</b> : 32x normal speed  <u>0003</u> <b>x60</b> : 60x normal speed  <u>0004</u> <b>x100</b> : 100x normal speed</p>
102 FF. REW MAX	<p>This sets the maximum speed for FF and REW operations.</p> <p><u>0000</u> <b>x32</b> : 32x normal speed  <u>0001</u> <b>x60</b> : 60x normal speed  <u>0002</u> <b>x100</b> : 100x normal speed</p>
104 REF ALARM	<p>This selects whether to warn the operator when the REF. VIDEO signal has not been connected.</p> <p><u>0000</u> <b>OFF</b> : Warning is not given.</p> <p><u>0001</u> <b>ON</b> : Warning is given by the flashing STOP lamp.</p> <p><b>Note:</b> Video and audio output may be disturbed when the reference video signal is not input, so it is recommended that a system which inputs the reference video signal be used.</p>

No./Item	Description
105 AUTO EE SEL	<p>This selects the memory card recorder mode in which the EE status is established when the MODE switch is set to EE.</p> <p><u>0000</u> <b>S/F/R</b> : EE status is established in STOP, FF and REW modes. However, EE status is established at all times when the card is ejected, regardless of the MODE switch setting.</p> <p><u>0001</u> <b>STOP</b> : EE status is established in STOP mode. However, EE status is established at all times when the card is ejected, regardless of the MODE switch setting.</p> <p><u>0002</u> <b>BLACK</b> : EE status is established in STOP mode. However, when the card is ejected, if the MODE switch is set to; <b>EE</b>: EE status is established. <b>PB</b>: The picture becomes black and the sound is muted.</p> <p><u>0003</u> <b>BLACK1</b> : EE status is established in STOP, FF and REW modes. However, when the card is ejected, if the MODE switch is set to; <b>EE</b>: EE status is established. <b>PB</b>: The picture becomes black and the sound is muted.</p> <p><u>0004</u> <b>GRAY</b> : EE status is established in STOP mode. However, when the card is ejected, if the MODE switch is set to; <b>EE</b>: EE status is established. <b>PB</b>: The picture becomes gray and the sound is muted.</p> <p><u>0005</u> <b>GRAY1</b> : EE status is established in STOP, FF and REW modes. However, when the card is ejected, if the MODE switch is set to; <b>EE</b>: EE status is established. <b>PB</b>: The picture becomes gray and the sound is muted.</p>

The underlined items indicates the initial setting.

## Setup menus (continued)

### ■ USER menu <OPERATION>

No./Item	Description
106 EE MODE SEL	<p>This selects the EE mode output signals.</p> <p><u>0000</u> <b>NORMAL</b> : Signals are output with a delay equivalent to the length of internal signal processing.</p> <p><b>0001 THRU</b> : Signals are output directly, without internal processing, and so are output with no delay.</p> <p><b>Note:</b> When 1394 has been selected for the video input signals or when INT SG has been selected for video or audio, internal operations are forcibly set to NORMAL.</p>
107 PLAY DELAY	<p>This set the play delay time in frame increments.</p> <p><u>0000</u>    <u>0</u> :        : 0015    15</p>
112 V IN SEL INH	<p>This selects whether video input switching using the INPUT SELECT button is to be enabled or disabled.</p> <p><b>0000 OFF</b> : Video input switching using the INPUT SELECT button is enabled.</p> <p><b>0001 ON</b> : Video input switching using the INPUT SELECT button is disabled.</p> <p><b>0002 REC</b> : Video input switching using the INPUT SELECT button after the memory card recorder has been transferred to a recording mode is disabled.</p>

No./Item	Description
113 A IN SEL INH	<p>This selects whether audio input switching using the INPUT SELECT button is to be enabled or disabled.</p> <p><b>0000 OFF</b> : Audio input switching using the INPUT SELECT button is enabled.</p> <p><b>0001 ON</b> : Audio input switching using the INPUT SELECT button is disabled.</p> <p><b>0002 REC</b> : Audio input switching using the INPUT SELECT button after the memory card recorder has been transferred to a recording mode is disabled.</p> <p><b>Note:</b> Even when the ON or REC setting is selected to disable audio input switching using the INPUT SELECT button, it is still possible to set the setup menu items No. 715 (CH1 IN SEL), No. 716 (CH2 IN SEL), No. 717 (CH3 IN SEL), No. 718 (CH4 IN SEL), No. 719 (D IN SEL12) and No. 720 (D IN SEL34).</p>

The underlined items indicates the initial setting.

## Setup menus (continued)

### ■ USER menu <INTERFACE>

No./Item	Description
201 9P SEL	<p>This selects whether the REMOTE (9P) connector functions when the REMOTE button is lit.</p> <p><b>0000 OFF :</b> Connector does not function. <b>0001 ON :</b> Connector functions.</p>
202 ID SEL	<p>This sets the ID information to be returned to the controller.</p> <p><b>0000 OTHER</b> <b>0001 <u>DVCPRO</u></b> <b>0002 ORIG</b></p> <p>Notes: •ID information of any VTR except for the DVCPRO's is set in OTHER. •Select ORIG only when the unit has been connected to the specified controller.</p>
204 RS232C SEL	<p>This selects whether the RS-232C connector functions when the REMOTE button is lit.</p> <p><b>0000 <u>OFF</u> :</b> Connector does not function. <b>0001 ON :</b> Connector functions.</p>
205 BAUD RATE	<p>These settings are for selecting the RS-232C communication speed (baud rate). (Unit: Bps)</p> <p><b>0000 300</b> <b>0001 600</b> <b>0002 1200</b> <b>0003 2400</b> <b>0004 4800</b> <b>0005 <u>9600</u></b></p>
206 DATA LENGTH	<p>These settings are for selecting the RS-232C data length. (Unit: bit)</p> <p><b>0000 7</b> <b>0001 <u>8</u></b></p>
207 STOP BIT	<p>These settings are for selecting the RS-232C stop bit length. (Unit: bit)</p> <p><b>0000 1</b> <b>0001 <u>2</u></b></p>

No./Item	Description
208 PARITY	<p>These settings are for selecting the none, odd or even for the RS-232C parity bit.</p> <p><b>0000 <u>NON</u> :</b> Parity bit is not used. <b>0001 ODD:</b> An odd number of bits is used for the parity system. <b>0002 EVEN:</b> An even number of bits is used for the parity system.</p>
209 RETURN ACK	<p>These settings are for selecting whether the ACK code is to be returned when a command is received from RS-232C.</p> <p><b>0000 OFF :</b> ACK code is not returned. <b>0001 <u>ON</u> :</b> ACK code is returned.</p>

The underlined items indicates the initial setting.

## Setup menus (continued)

### ■ USER menu <EDIT>

No./Item	Description
303 STD/NON-STD	<p>This selects <b>STD</b> or <b>NON-STD</b> in accordance with the composite input signal.</p> <p><u>0000</u> <b>AUTO</b> : Standard/non-standard signals are automatically identified and processed.</p> <p>0001 <b>STD</b> : Standard signals are processed. (Forced STD)</p> <p>0002 <b>N-STD</b> : Non-standard signals are processed. (Forced NON-STD)</p> <p><b>Notes:</b></p> <ul style="list-style-type: none"> <li>•Use the non-standard (NON-STD) setting when video or audio trouble occurs with signals from laser discs or a satellite.</li> <li>•At the NON-STD setting, the images shown on the front panel's LCD monitor will be significantly disrupted when the unit's operation is transferred from the play mode to EE mode: this is normal and not indicative of malfunctioning.</li> </ul>
304 REF LOCK	<p>This selects the <b>REF LOCK</b> mode.</p> <p><u>0000</u> <b>AUTO</b> : Servo is synchronized with the input signal during recording, or with the REF signal during playback.</p> <p>0001 <b>EXT</b> : Servo is synchronized at all times with the REF signal.</p> <p>0002 <b>AUTO1</b> : Servo is synchronized with the input signal during recording, or with the REF signal during playback. When there is no reference (REF) signal, the EE output is synchronized with the internal reference signal at the AUTO setting or with the STD input signal at the AUTO1 setting. The AUTO1 setting is selected when the STD signal is to be used.</p> <p><b>Note:</b> At the AUTO setting, the images shown on the front panel's LCD monitor will be significantly disrupted when the unit's operation is transferred from the play mode to EE mode: this is normal and not indicative of malfunctioning.</p>

No./Item	Description
315 AFTER CUE-UP	<p>This selects the mode after cue-up operation is complete.</p> <p><u>0000</u> <b>STOP</b> : STOP mode 0001 <b>STILL</b> : SHTL STILL mode</p>
320 VAR FWD MAX	<p>This sets the maximum <b>SLOW FWD</b> speed.</p> <p><u>0000</u> <b>+4</b> : +4x speed 0001 <b>+2</b> : +2x speed 0002 <b>+1</b> : +1x speed</p> <p><b>Note:</b> At any speed setting other than 0 (+4), the phase cannot be synchronized from the editing controller.</p>
321 VAR REV MAX	<p>This sets the maximum <b>SLOW REV</b> speed.</p> <p><u>0000</u> <b>-4</b> : -4x speed 0001 <b>-2</b> : -2x speed 0002 <b>-1</b> : -1x speed</p>
323 JOG FWD MAX	<p>This sets the maximum <b>JOG FWD</b> speed.</p> <p><u>0000</u> <b>+4</b> : +4x speed 0001 <b>+2</b> : +2x speed <u>0002</u> <b>+1</b> : +1x speed</p> <p><b>Notes:</b></p> <ul style="list-style-type: none"> <li>•The maximum speed is set to +1 x when the dial on the front panel is operated.</li> <li>•At any speed setting other than 0 (+4), the phase cannot be synchronized from an editing controller which synchronizes the phase using the JOG command.</li> </ul>
324 JOG REV MAX	<p>This sets the maximum <b>JOG REV</b> speed.</p> <p><u>0000</u> <b>-4</b> : -4x speed 0001 <b>-2</b> : -2x speed <u>0002</u> <b>-1</b> : -1x speed</p> <p><b>Note:</b> The maximum speed is set to -1 x when the dial on the front panel is operated.</p>

The underlined items indicates the initial setting.

# Setup menus (continued)

## ■ USER menu <TIME CODE>

No./Item	Description												
500 VITC BLANK	<p>This selects whether to output the VITC signal at the positions selected by setup menu items No. 501 (VITC POS-1) and No. 502 (VITC POS-2).</p> <p><b>0000 BLANK :</b> VITC signals are not output.</p> <p><b>0001 THRU :</b> VITC signals are output.</p>												
501 VITC POS-1	<p>This sets the position where the VITC signal is to be inserted.</p> <table style="width: 100%; border: none;"> <tr> <td style="text-align: center;">[525i system]</td> <td style="text-align: center;">[625i system]</td> </tr> <tr> <td style="text-align: center;"><b>0000 10L</b></td> <td style="text-align: center;"><b>0000 7L</b></td> </tr> <tr> <td style="text-align: center;">:</td> <td style="text-align: center;">:</td> </tr> <tr> <td style="text-align: center;"><b>0006 16L</b></td> <td style="text-align: center;"><b>0004 11L</b></td> </tr> <tr> <td style="text-align: center;">:</td> <td style="text-align: center;">:</td> </tr> <tr> <td style="text-align: center;"><b>0010 20L</b></td> <td style="text-align: center;"><b>0015 22L</b></td> </tr> </table> <p><b>Note:</b> The same line as the one used for the setup menu items No. 502 (VITC POS-2) and No. 662 (UMID POS) setting cannot be set.</p>	[525i system]	[625i system]	<b>0000 10L</b>	<b>0000 7L</b>	:	:	<b>0006 16L</b>	<b>0004 11L</b>	:	:	<b>0010 20L</b>	<b>0015 22L</b>
[525i system]	[625i system]												
<b>0000 10L</b>	<b>0000 7L</b>												
:	:												
<b>0006 16L</b>	<b>0004 11L</b>												
:	:												
<b>0010 20L</b>	<b>0015 22L</b>												
502 VITC POS-2	<p>This sets the position where the VITC signal is to be inserted.</p> <table style="width: 100%; border: none;"> <tr> <td style="text-align: center;">[525i system]</td> <td style="text-align: center;">[625i system]</td> </tr> <tr> <td style="text-align: center;"><b>0000 10L</b></td> <td style="text-align: center;"><b>0000 7L</b></td> </tr> <tr> <td style="text-align: center;">:</td> <td style="text-align: center;">:</td> </tr> <tr> <td style="text-align: center;"><b>0008 18L</b></td> <td style="text-align: center;"><b>0006 13L</b></td> </tr> <tr> <td style="text-align: center;">:</td> <td style="text-align: center;">:</td> </tr> <tr> <td style="text-align: center;"><b>0010 20L</b></td> <td style="text-align: center;"><b>0015 22L</b></td> </tr> </table> <p><b>Note:</b> The same line as the one used for the setup menu items No. 501 (VITC POS-1) and No. 662(UMID POS) setting cannot be set.</p>	[525i system]	[625i system]	<b>0000 10L</b>	<b>0000 7L</b>	:	:	<b>0008 18L</b>	<b>0006 13L</b>	:	:	<b>0010 20L</b>	<b>0015 22L</b>
[525i system]	[625i system]												
<b>0000 10L</b>	<b>0000 7L</b>												
:	:												
<b>0008 18L</b>	<b>0006 13L</b>												
:	:												
<b>0010 20L</b>	<b>0015 22L</b>												
503 TCG REGEN	<p>This selects the signal to be regenerated when the time code generator (TCG) in the REGEN mode.</p> <p><b>0000 TC&amp;UB :</b> Both the time code and user bit are regenerated.</p> <p><b>0001 TC :</b> Only the time code is regenerated.</p> <p><b>0002 UB :</b> Only the user bit is regenerated.</p>												

The underlined items indicates the initial setting.

No./Item	Description
505 EXT TC SEL	<p>This selects the time code to be used when an external time code is to be used.</p> <p><b>0000 LTC :</b> The LTC of the TIME CODE IN connector is used.</p> <p><b>0001 VITC :</b> The VITC of the input video signal is used.</p> <p><b>Note:</b> During recording, there is a discrepancy in the picture and superimposed TC value displayed, but the actual recording is not adversely affected in any way.</p>
506 BINARY GP	<p>This sets the usage status of the user bit of the time code generated by the TCG.</p> <p><b>0000 000 :</b> NOT SPECIFIED (character set not specified)</p> <p><b>0001 001 :</b> ISO CHARACTER (8 bits character set based on ISO646, ISO2022)</p> <p><b>0002 010 :</b> UNASSIGNED 1 (undefined)</p> <p><b>0003 011 :</b> UNASSIGNED 2 (undefined)</p> <p><b>0004 100 :</b> UNASSIGNED 3 (undefined)</p> <p><b>0005 101 :</b> PAGE/LINE</p> <p><b>0006 110 :</b> UNASSIGNED 4 (undefined)</p> <p><b>0007 111 :</b> UNASSIGNED 5 (undefined)</p>
507 PHASE CORR	<p>This selects whether to control the phase correction of the LTC which is output from the TIME CODE OUT connector.</p> <p><b>0000 OFF :</b> Phase correction control is not performed.</p> <p><b>0001 ON :</b> Phase correction control is performed.</p>
508 TCG CF FLAG	<p>This selects whether the CF flag of the TCG is to ON.</p> <p><b>0000 OFF :</b> CF flag is OFF.</p> <p><b>0001 ON :</b> CF flag is ON.</p>
509 DF MODE	<p>This selects the DF or NDF mode for CTL and TCG.</p> <p><b>0000 DF :</b> The drop frame mode is used.</p> <p><b>0001 NDF :</b> The non-drop frame mode is used.</p> <p><b>Notes:</b></p> <ul style="list-style-type: none"> <li>•Drop frame mode is valid only when the REMOTE button is lit or the setup menu No. 001 (LOCAL ENA) is set to ENA.</li> <li>•This menu option is not displayed in the 625i system.</li> </ul>

## Setup menus (continued)

### ■ USER menu <TIME CODE>

No./Item	Description
510 TC OUT REF	<p>This is used to switch the phase of the time code, which is output from the TIME CODE OUT connector, for the external LTC input when the TCG switch is at the "EXT" position.</p> <p><u>0000</u> <b>V OUT</b> : Time code is synchronized with output video signal.</p> <p><u>0001</u> <b>TC_IN</b> : Time code is synchronized with external time code input.</p>
511 VITC OUT	<p>This selects how the VITC which is to be superimposed onto the output video signal during playback is to be output.</p> <p><u>0000</u> <b>SBC</b> : The time code recorded in the sub code area is output as the VITC.</p> <p><u>0001</u> <b>VAUX</b> : The time code recorded in the VAUX area is output as the VITC.</p>
514 VITC GEN	<p>This selects whether or not to record the internal time code generator value in the VAUX area.</p> <p><u>0000</u> <b>OFF</b> : The internal time code generator value is not recorded in the VAUX area. When video signals on which the time code has been recorded are input, the time code of the input signals is recorded in the VAUX area.</p> <p><u>0001</u> <b>ON</b> : The internal time code generator value is recorded in the VAUX area.</p> <p><b>Note:</b> If 1394 has been selected as the input signals, the time code on the input compressed signals will be recorded regardless of this menu's setting.</p>

#### Sub code area:

This area is separate from the video and audio data area on the P2 card. The time code complying with SMPTE/EBU standards is stored here.

#### VAUX area:

This area is to be found in the video data area on the P2 card. The additional information relating to the video data is stored here.

### ■ USER menu <VIDEO>

No./Item	Description
600 INT SG	<p>This selects the internal signal.</p> <p><u>0001</u> <b>BB</b> : The black burst is generated.</p> <p><u>0002</u> <b>CB100</b> : 100% color bars are generated.</p> <p><u>0003</u> <b>CB75</b> : 75% color bars are generated.</p>
601 OUT VSYNC	<p>This selects whether to float the vertical sync position of the video output in order to align the video output phase with the input in the EE/record/edit modes.</p> <p><u>0000</u> <b>N-VF</b> : Signals are not floated.</p> <p><u>0001</u> <b>VF</b> : Signals are floated.</p>
603 CC (F1) BLANK	<p>This selects ON or OFF for the closed caption signal of the first field.</p> <p><u>0000</u> <b>BLANK</b> : Signal is forcibly blanked.</p> <p><u>0001</u> <b>THRU</b> : Signal is not blanked.</p> <p><b>Note:</b> This menu option is not displayed in the 625i system.</p>
604 CC (F2) BLANK	<p>This selects ON or OFF for the closed caption signal of the second field.</p> <p><u>0000</u> <b>BLANK</b> : Signal is forcibly blanked.</p> <p><u>0001</u> <b>THRU</b> : Signal is not blanked.</p> <p><b>Note:</b> This menu option is not displayed in the 625i system.</p>
605 FREEZE SEL	<p>This selects the freeze mode for still pictures.</p> <p><u>0000</u> <b>FIELD</b> : Field freeze.</p> <p><u>0001</u> <b>FRAME</b> : Frame freeze.</p> <p><b>Notes:</b></p> <ul style="list-style-type: none"> <li>•When frame freeze has been selected, the frame slow status is established with the slow setting.</li> <li>•This setting is also followed when there is a freeze command from the RS-422A connector, but the picture displayed on the LCD monitor screen shown at this time will not be frozen.</li> </ul>
606 OUT C KILL	<p>This selects chroma color killer processing for the video output signals.</p> <p><u>0000</u> <b>B/W</b> : No color signals are output.</p> <p><u>0001</u> <b>COLOR</b> : Color signals are output.</p>

The underlined items indicates the initial setting.

## Setup menus (continued)

### ■ USER menu <VIDEO>

No./Item	Description
609 EDH	<p>This selects whether to superimpose EDH onto the SDI output signals.</p> <p><b>0000 OFF</b> : EDH is not superimposed.  <b>0001 ON</b> : EDH is superimposed.</p> <p><b>Note:</b>            Even when ON is selected for this setting, EDH is not superimposed onto the signals output from the SDI OUT 3 connector (optional) if the SUPER switch on the front panel is set to ON.</p>
610 P <sub>B</sub> /P <sub>R</sub> IN LV	<p>This selects the analog component input level.</p> <p><b>0000 M II</b> : M II level  <b>0001 B-CAM</b> : β-CAM level</p> <p><b>Note:</b>            This menu option is not displayed in the 625i system.</p>
611 YC SEP MODE	<p>This selects Y/C separation processing for the composite input signals.</p> <p><b>0000 B/W</b> :            The signals are processed as B/W signals.  <b>0001 AUTO</b> :            The signals are automatically detected.</p>
614 P <sub>B</sub> /P <sub>R</sub> OUT LV	<p>This selects the analog component output level.</p> <p><b>0000 M II</b> : M II level  <b>0001 B-CAM</b> : β-CAM level</p> <p><b>Note:</b>            This menu option is not displayed in the 625i system.</p>
618 INTERPOLATE	<p>This selects the interpolation operation.</p> <p>Vertical interpolation is conducted automatically during slow-motion playback to reduce the vertical movement of the playback pictures. However, this menu item enables the interpolation operation to be forcibly turned off.</p> <p><b>0000 OFF</b> :            Interpolation is forcibly turned off.  <b>0001 AUTO</b> :            Interpolation is automatically turned on during slow-motion playback.</p>

No./Item	Description
620 ESR MODE	<p>This selects the operation mode for edge subcarrier reduction (ESR) in the playback circuit.</p> <p><b>0000 OFF</b> :            The mode is forcibly set to OFF.  <b>0001 AUTO</b> :            The mode is automatically set to ON or OFF depending on the memory card recorder operation.</p>
621 CCR MODE	<p>This selects the cross color processing during playback.</p> <p><b>0000 OFF</b> :            The cross color is output with no changes made.  <b>0001 ON</b> :            The cross color can be reduced.</p> <p><b>Note:</b>            This menu option is not displayed in the 625i system.</p>
624 CC REC	<p>This selects whether to record the closed caption signals multiplexed on the input signals on the card.</p> <p><b>0000 OFF</b> :            No closed caption signal is recorded. In addition, the EE output signals are blanked.  <b>0001 ON</b> :            When a closed caption signal is detected from the selected input signal, it can be recorded on the card.</p> <p><b>Notes:</b></p> <ul style="list-style-type: none"> <li>• This menu option is not displayed in the 625i system.</li> <li>• If 1394 has been selected as the input signals, the closed caption signal on the input compressed signals will be recorded regardless of this menu's setting.</li> </ul>
645 WIDE SELECT	<p>This selects whether to record the WIDE information on the card.</p> <p><b>0001 WIDE</b> :            The information is recorded.  <b>0002 NORMAL</b> :            No information is recorded.</p> <p><b>Note:</b>            If 1394 has been selected as the input signals, the input information will be recorded.</p>

The underlined items indicates the initial setting.



## Setup menus (continued)

### ■ USER menu <VIDEO>

No./Item	Description
<b>622</b> <b>SETUP 25</b> (For AJ-SPD850P)	<p>For setting 7.5% setup processing to be performed on input and output signals in the DVCPRO (25 Mbps) mode.</p> <p>When the STOP button is pressed, operation is transferred to the sub-screen, and the setup level is set for each output. To return from the sub-screen, press the STOP button again.</p> <p><b>Note:</b> This setup menu is not displayed in the 625i system.</p>
<b>Sub-screen</b>	
<b>00</b> <b>CMPST IN</b>	<p>This selects the 7.5% setup processing for the input composite signal.</p> <p><b>0000 THRU :</b> The signal is recorded in its original form.</p> <p><b>0001 CUT :</b> The signal is recorded with the 7.5% setup removed.</p>
<b>01</b> <b>CMPST OUT</b>	<p>This selects the 7.5% setup processing for the output composite signal.</p> <p><b>0000 THRU :</b> The signal is output in its original form.</p> <p><b>0001 ADD :</b> The signal is output with the 7.5% setup added.</p> <p><b>Note:</b> Bear in mind the setting for sub-screen item No. 03 (CMPNT OUT) of setup menu item No. 622 (SETUP 25).</p>
<b>02</b> <b>CMPNT IN</b>	<p>This selects the 7.5% setup processing for the input component signal.</p> <p><b>0000 THRU :</b> The signal is recorded in its original form.</p> <p><b>0001 CUT :</b> The signal is recorded with the 7.5% setup removed.</p>
<b>03</b> <b>CMPNT OUT</b>	<p>This selects the 7.5% setup processing for the output composite, component and serial (digital) signal.</p> <p><b>0000 THRU :</b> The signal is output in its original form.</p> <p><b>0001 CUT :</b> The signal is output with the 7.5% setup removed.</p> <p><b>0002 ADD :</b> The signal is output with the 7.5% setup added.</p>

No./Item	Description
<b>623</b> <b>SETUP 50</b> (For AJ-SPD850P)	<p>For setting 7.5% setup processing to be performed on input and output signals in the DVCPRO50 (50 Mbps) mode.</p> <p>When the STOP button is pressed, operation is transferred to the sub-screen, and the setup level is set for each output. To return from the sub-screen, press the STOP button again.</p> <p><b>Note:</b> This setup menu is not displayed in the 625i system.</p>
<b>Sub-screen</b>	
<b>00</b> <b>CMPST IN</b>	<p>This selects the 7.5% setup processing for the input composite signal.</p> <p><b>0000 THRU :</b> The signal is recorded in its original form.</p> <p><b>0001 CUT :</b> The signal is recorded with the 7.5% setup removed.</p>
<b>01</b> <b>CMPST OUT</b>	<p>This selects the 7.5% setup processing for the output composite signal.</p> <p><b>0000 THRU :</b> The signal is output in its original form.</p> <p><b>0001 ADD :</b> The signal is output with the 7.5% setup added.</p> <p><b>Note:</b> Bear in mind the setting for sub-screen item No. 03 (CMPNT OUT) of setup menu item No. 623 (SETUP 50).</p>
<b>02</b> <b>CMPNT IN</b>	<p>This selects the 7.5% setup processing for the input component signal.</p> <p><b>0000 THRU :</b> The signal is recorded in its original form.</p> <p><b>0001 CUT :</b> The signal is recorded with the 7.5% setup removed.</p>
<b>03</b> <b>CMPNT OUT</b>	<p>This selects the 7.5% setup processing for the output composite, component and serial (digital) signal.</p> <p><b>0000 THRU :</b> The signal is output in its original form.</p> <p><b>0001 CUT :</b> The signal is output with the 7.5% setup removed.</p> <p><b>0002 ADD :</b> The signal is output with the 7.5% setup added.</p>

The underlined items indicates the initial setting.

## Setup menus (continued)

### ■ USER menu <VIDEO>

No./Item	Description														
660 UMID REC	<p>This selects whether or not to record the UMID information on the card.</p> <p><b>0000 OFF :</b> UMID information is not recorded on the card. In addition, EE output signals are blanked.</p> <p><b><u>0001</u> ON :</b> UMID information is recorded on the card.</p> <p><b>Note:</b> If THRU has been selected as the setup menu item No. 106 (EE MODE SEL) setting, UMID information of the EE output signals will be blanked.</p>														
661 UMID GEN	<p>This selects the UMID information to be recorded on the card when ON has been selected as the setup menu item No. 660 (UMID REC) setting.</p> <p><b>0000 INT :</b> Newly created UMID information of this unit is always recorded.</p> <p><b><u>0001</u> EXT :</b> The UMID information of the input signals is recorded. Newly created UMID information of this unit is recorded if there is no UMID information on the input signals.</p>														
662 UMID POS	<p>This sets the line on which the UMID information is to be superimposed.</p> <table style="width: 100%; border-collapse: collapse;"> <thead> <tr> <th style="text-align: left;">[525i system]</th> <th style="text-align: left;">[625i system]</th> </tr> </thead> <tbody> <tr> <td><b>0000 BLANK</b></td> <td><b>0000 BLANK</b></td> </tr> <tr> <td><b>0001 12L</b></td> <td><b>0001 18L</b></td> </tr> <tr> <td style="text-align: center;">:</td> <td style="text-align: center;">:</td> </tr> <tr> <td><b><u>0006</u> 17L</b></td> <td><b><u>0010</u> 17L</b></td> </tr> <tr> <td style="text-align: center;">:</td> <td style="text-align: center;">:</td> </tr> <tr> <td><b>0008 19L</b></td> <td><b>0015 22L</b></td> </tr> </tbody> </table> <p><b>Note:</b> The line selected for the setup menu item No. 501 (VITC POS-1) and No. 502 (VITC POS-2) settings cannot be selected for this item.</p>	[525i system]	[625i system]	<b>0000 BLANK</b>	<b>0000 BLANK</b>	<b>0001 12L</b>	<b>0001 18L</b>	:	:	<b><u>0006</u> 17L</b>	<b><u>0010</u> 17L</b>	:	:	<b>0008 19L</b>	<b>0015 22L</b>
[525i system]	[625i system]														
<b>0000 BLANK</b>	<b>0000 BLANK</b>														
<b>0001 12L</b>	<b>0001 18L</b>														
:	:														
<b><u>0006</u> 17L</b>	<b><u>0010</u> 17L</b>														
:	:														
<b>0008 19L</b>	<b>0015 22L</b>														

### ■ USER menu <AUDIO>

No./Item	Description
701 CH1 IN LV	<p>This selects the audio input (CH1) reference level switching.</p> <p><b>0000 4dB</b> <b><u>0001</u> 0dB</b> <b>0002 -20dB</b></p>
702 CH2 IN LV	<p>This selects the audio input (CH2) reference level switching.</p> <p><b>0000 4dB</b> <b>0001 0dB</b> <b>0002 -20dB</b></p>
703 CH3 IN LV	<p>This selects the audio input (CH3) reference level switching.</p> <p><b>0000 4dB</b> <b><u>0001</u> 0dB</b> <b>0002 -20dB</b></p>
704 CH4 IN LV	<p>This selects the audio input (CH4) reference level switching.</p> <p><b>0000 4dB</b> <b><u>0001</u> 0dB</b> <b>0002 -20dB</b></p>
706 CH1 OUT LV	<p>This selects the audio output (CH1) reference level switching.</p> <p><b>0000 4dB</b> <b><u>0001</u> 0dB</b> <b>0002 -20dB</b></p>
707 CH2 OUT LV	<p>This selects the audio output (CH2) reference level switching.</p> <p><b>0000 4dB</b> <b><u>0001</u> 0dB</b> <b>0002 -20dB</b></p>
708 CH3 OUT LV	<p>This selects the audio output (CH3) reference level switching.</p> <p><b>0000 4dB</b> <b><u>0001</u> 0dB</b> <b>0002 -20dB</b></p>
709 CH4 OUT LV	<p>This selects the audio output (CH4) reference level switching.</p> <p><b>0000 4dB</b> <b><u>0001</u> 0dB</b> <b>0002 -20dB</b></p>

The underlined items indicates the initial setting.

## Setup menus (continued)

### ■ USER menu <AUDIO>

No./Item	Description
711 MONIL OUT LV	This selects the audio monitor output (Lch) reference level switching.  0000 4dB <u>0001 0dB</u> 0002 -20dB
712 MONIR OUT LV	This selects the audio monitor output (Rch) reference level switching.  0000 4dB <u>0001 0dB</u> 0002 -20dB
713 MONI OUT	This selects whether to link the volume level of the audio monitor output to the setting of the headphone volume control.  0000 <b>UNITY</b> : The sound is output at a fixed level regardless of the position of the volume control. <u>0001 VAR</u> : The volume level is linked to the setting of the volume control.
715 CH1 IN SEL	This selects the CH1 input when USER SET has been selected by pressing the memory card recorder's AUDIO INPUT SELECT button.  0000 <b>ANA</b> : Analog input. 0001 <b>DIGI</b> : Digital input.
716 CH2 IN SEL	This selects the CH2 input when USER SET has been selected by pressing the memory card recorder's AUDIO INPUT SELECT button.  0000 <b>ANA</b> : Analog input. 0001 <b>DIGI</b> : Digital input.
717 CH3 IN SEL	This selects the CH3 input when USER SET has been selected by pressing the memory card recorder's AUDIO INPUT SELECT button.  0000 <b>ANA</b> : Analog input. 0001 <b>DIGI</b> : Digital input.
718 CH4 IN SEL	This selects the CH4 input when USER SET has been selected by pressing the memory card recorder's AUDIO INPUT SELECT button.  0000 <b>ANA</b> : Analog input. 0001 <b>DIGI</b> : Digital input.

No./Item	Description
719 D IN SEL12	This selects the CH1 and CH2 digital input when USER SET has been selected by pressing the memory card recorder's AUDIO INPUT SELECT button.  0000 <b>AES</b> : AES input 0001 <b>SIF</b> : SDI input
720 D IN SEL34	This selects the CH3 and CH4 digital input when USER SET has been selected by pressing the memory card recorder's AUDIO INPUT SELECT button.  0000 <b>AES</b> : AES input 0001 <b>SIF</b> : SDI input
727 PB FADE	This selects the processing method for the audio edit points (IN point, OUT point) during playback etc.  0000 <b>AUTO</b> : The processing method accords with the status established during recording. 0001 <b>CUT</b> : Forced CUT 0002 <b>FADE</b> : Forced FADE
728 EMBEDDED AUD	This selects whether to superimpose the audio data onto the SDI output.  0000 <b>OFF</b> : Data is not superimposed. 0001 <b>ON</b> : Data is superimposed.
734 MONI SEL INH	This selects whether the operation of the MONITOR SELECT button on the front panel is to be enabled or disabled.  0000 <b>OFF</b> : Operation is enabled. 0001 <b>ON</b> : Operation is disabled. 0002 <b>ON1</b> : Operation is disabled in the FULL display mode and enabled only in the FINE display mode.
754 AMIX SEL INH	This selects the input audio channel switching mode using the REC CH1/CH3 and REC CH2/CH4 buttons.  0000 <b>OFF</b> : The audio input channels can be switched using the REC CH buttons. 0001 <b>ON</b> : Switching of the audio input channels using the REC CH buttons is prohibited. 0002 <b>REC</b> : After the unit's operation has been transferred to recording, switching of the audio input channels using the REC CH buttons is prohibited.

The underlined items indicates the initial setting.

# Setup menus (continued)

## ■ USER menu <V BLANK>

No./Item	Description
755 25M REC CH	<p>Used to select the number of AUDIO channels for DVCPRO (25 Mbps) or DV (25 Mbps) recording.</p> <p><b>0000 2CH:</b> Records on two channels.</p> <p><b>0001 4CH:</b> Records on four channels.</p> <p><b>Note:</b> Four-channel recording is always used with DVCPRO50 (50 Mbps).</p>
800 ADD LINE 25	<p>This selects the mode for recording signals on additional lines.</p> <p><b>0000 OFF:</b> No signals are recorded on additional lines.</p> <p><b>0001 YC422:</b> The 422 mode signals are recorded on 1 line.</p> <p><b>0002 YC411:</b> The 411 mode signals are recorded on 1 line.</p> <p><b>0003 Y1_B/W:</b> Only the Y signal is recorded on 1 line directly.</p> <p><b>0004 Y1_BPF:</b> Only the Y signal is recorded on 1 line after it has been separated from the C signal.</p> <p><b>0005 C1:</b> Only the C signal is recorded on 1 line.</p> <p><b>0006 Y2_B/W:</b> Only the Y signal is recorded on 2 lines directly.</p> <p><b>0007 Y2_BPF:</b> Only the Y signal is recorded on 2 lines after it has been separated from the C signal.</p> <p><b>0008 C2:</b> Only the C signal is recorded on 2 lines.</p> <p><b>Notes:</b></p> <ul style="list-style-type: none"> <li>•When a setting from "0001 (YC422)" to "0008 (C2)" is selected and the STOP button is pressed, operation transfers to the sub-screen, and the recording line or lines can be selected. To return from the sub-screen, press the STOP button again.</li> <li>•The setting takes effect when the system format is 25 Mbps.</li> </ul>

No./Item	Description																						
Sub-screen																							
00 REC LINE1	<p>This selects the additional line where the signals are to be recorded.</p> <table> <tr> <td>[525i system]</td> <td>[625i system]</td> </tr> <tr> <td><b>0000 10L</b></td> <td><b>0000 7L</b></td> </tr> <tr> <td>: :</td> <td>: :</td> </tr> <tr> <td><b>0002 12L</b></td> <td><b>0002 9L</b></td> </tr> <tr> <td>: :</td> <td>: :</td> </tr> <tr> <td><b>0012 22L</b></td> <td><b>0015 22L</b></td> </tr> <tr> <td><b>0013 263L</b></td> <td><b>0016 320L</b></td> </tr> <tr> <td><b>0014 273L</b></td> <td>: :</td> </tr> <tr> <td>: :</td> <td><b>0031 335L</b></td> </tr> <tr> <td><b>0025 284L</b></td> <td><b>0032 623L</b></td> </tr> <tr> <td><b>0026 525L</b></td> <td></td> </tr> </table>	[525i system]	[625i system]	<b>0000 10L</b>	<b>0000 7L</b>	: :	: :	<b>0002 12L</b>	<b>0002 9L</b>	: :	: :	<b>0012 22L</b>	<b>0015 22L</b>	<b>0013 263L</b>	<b>0016 320L</b>	<b>0014 273L</b>	: :	: :	<b>0031 335L</b>	<b>0025 284L</b>	<b>0032 623L</b>	<b>0026 525L</b>	
[525i system]	[625i system]																						
<b>0000 10L</b>	<b>0000 7L</b>																						
: :	: :																						
<b>0002 12L</b>	<b>0002 9L</b>																						
: :	: :																						
<b>0012 22L</b>	<b>0015 22L</b>																						
<b>0013 263L</b>	<b>0016 320L</b>																						
<b>0014 273L</b>	: :																						
: :	<b>0031 335L</b>																						
<b>0025 284L</b>	<b>0032 623L</b>																						
<b>0026 525L</b>																							
01 REC LINE2	<p>This selects the additional line where the signals are to be recorded.</p> <table> <tr> <td>[525i system]</td> <td>[625i system]</td> </tr> <tr> <td><b>0000 10L</b></td> <td><b>0000 7L</b></td> </tr> <tr> <td>: :</td> <td>: :</td> </tr> <tr> <td><b>0012 22L</b></td> <td><b>0015 22L</b></td> </tr> <tr> <td><b>0013 263L</b></td> <td><b>0016 320L</b></td> </tr> <tr> <td><b>0014 273L</b></td> <td>: :</td> </tr> <tr> <td>: :</td> <td><b>0018 322L</b></td> </tr> <tr> <td><b>0016 275L</b></td> <td>: :</td> </tr> <tr> <td>: :</td> <td><b>0031 335L</b></td> </tr> <tr> <td><b>0025 284L</b></td> <td><b>0032 623L</b></td> </tr> <tr> <td><b>0026 525L</b></td> <td></td> </tr> </table> <p><b>Note:</b> This menu option is not displayed when additional line mode setting "1" through "5" has been selected.</p>	[525i system]	[625i system]	<b>0000 10L</b>	<b>0000 7L</b>	: :	: :	<b>0012 22L</b>	<b>0015 22L</b>	<b>0013 263L</b>	<b>0016 320L</b>	<b>0014 273L</b>	: :	: :	<b>0018 322L</b>	<b>0016 275L</b>	: :	: :	<b>0031 335L</b>	<b>0025 284L</b>	<b>0032 623L</b>	<b>0026 525L</b>	
[525i system]	[625i system]																						
<b>0000 10L</b>	<b>0000 7L</b>																						
: :	: :																						
<b>0012 22L</b>	<b>0015 22L</b>																						
<b>0013 263L</b>	<b>0016 320L</b>																						
<b>0014 273L</b>	: :																						
: :	<b>0018 322L</b>																						
<b>0016 275L</b>	: :																						
: :	<b>0031 335L</b>																						
<b>0025 284L</b>	<b>0032 623L</b>																						
<b>0026 525L</b>																							

The underlined items indicates the initial setting.

# Setup menus (continued)

## ■ USER menu <V BLANK>

No./Item	Description																						
801 ADD LINE 50	<p>This selects the mode for recording signals on additional lines.</p> <p><b>0000 OFF :</b> No signals are recorded on additional lines.</p> <p><b>0001 YC422 :</b> The 422 mode signals are recorded on 2 lines.</p> <p><b>0002 Y4_B/W :</b> Only the Y signal is recorded on 4 lines directly.</p> <p><b>0003 Y4_BPF :</b> Only the Y signal is recorded on 4 lines after it has been separated from the C signal.</p> <p><b>0004 C4 :</b> Only the C signal is recorded on 4 lines.</p> <p><b>Notes:</b></p> <ul style="list-style-type: none"> <li>•When a setting from “0001 (YC422)” to “0004 (C4)” is selected and the STOP button is pressed, operation transfers to the sub-screen, and the recording lines can be selected.</li> <li>To return from the sub-screen, press the STOP button again.</li> <li>•The setting takes effect when the system format is 50 Mbps.</li> </ul>																						
<b>Sub-screen</b>																							
00 REC LINE1	<p>This selects the additional line where the signals are to be recorded.</p> <table> <tr> <td>[525i system]</td> <td>[625i system]</td> </tr> <tr> <td><b>0000 10L</b></td> <td><b>0000 7L</b></td> </tr> <tr> <td>: :</td> <td>: :</td> </tr> <tr> <td><b>0002 12L</b></td> <td><b>0002 9L</b></td> </tr> <tr> <td>: :</td> <td>: :</td> </tr> <tr> <td><b>0012 22L</b></td> <td><b>0015 22L</b></td> </tr> <tr> <td><b>0013 263L</b></td> <td><b>0016 320L</b></td> </tr> <tr> <td><b>0014 273L</b></td> <td>: :</td> </tr> <tr> <td>: :</td> <td><b>0031 335L</b></td> </tr> <tr> <td><b>0025 284L</b></td> <td><b>0032 623L</b></td> </tr> <tr> <td><b>0026 525L</b></td> <td></td> </tr> </table>	[525i system]	[625i system]	<b>0000 10L</b>	<b>0000 7L</b>	: :	: :	<b>0002 12L</b>	<b>0002 9L</b>	: :	: :	<b>0012 22L</b>	<b>0015 22L</b>	<b>0013 263L</b>	<b>0016 320L</b>	<b>0014 273L</b>	: :	: :	<b>0031 335L</b>	<b>0025 284L</b>	<b>0032 623L</b>	<b>0026 525L</b>	
[525i system]	[625i system]																						
<b>0000 10L</b>	<b>0000 7L</b>																						
: :	: :																						
<b>0002 12L</b>	<b>0002 9L</b>																						
: :	: :																						
<b>0012 22L</b>	<b>0015 22L</b>																						
<b>0013 263L</b>	<b>0016 320L</b>																						
<b>0014 273L</b>	: :																						
: :	<b>0031 335L</b>																						
<b>0025 284L</b>	<b>0032 623L</b>																						
<b>0026 525L</b>																							
01 REC LINE2	<p>This selects the additional line where the signals are to be recorded.</p> <table> <tr> <td>[525i system]</td> <td>[625i system]</td> </tr> <tr> <td><b>0000 10L</b></td> <td><b>0000 7L</b></td> </tr> <tr> <td>: :</td> <td>: :</td> </tr> <tr> <td><b>0012 22L</b></td> <td><b>0015 22L</b></td> </tr> <tr> <td><b>0013 263L</b></td> <td><b>0016 320L</b></td> </tr> <tr> <td><b>0014 273L</b></td> <td>: :</td> </tr> <tr> <td>: :</td> <td><b>0018 322L</b></td> </tr> <tr> <td><b>0016 275L</b></td> <td>: :</td> </tr> <tr> <td>: :</td> <td><b>0031 335L</b></td> </tr> <tr> <td><b>0025 284L</b></td> <td><b>0032 623L</b></td> </tr> <tr> <td><b>0026 525L</b></td> <td></td> </tr> </table>	[525i system]	[625i system]	<b>0000 10L</b>	<b>0000 7L</b>	: :	: :	<b>0012 22L</b>	<b>0015 22L</b>	<b>0013 263L</b>	<b>0016 320L</b>	<b>0014 273L</b>	: :	: :	<b>0018 322L</b>	<b>0016 275L</b>	: :	: :	<b>0031 335L</b>	<b>0025 284L</b>	<b>0032 623L</b>	<b>0026 525L</b>	
[525i system]	[625i system]																						
<b>0000 10L</b>	<b>0000 7L</b>																						
: :	: :																						
<b>0012 22L</b>	<b>0015 22L</b>																						
<b>0013 263L</b>	<b>0016 320L</b>																						
<b>0014 273L</b>	: :																						
: :	<b>0018 322L</b>																						
<b>0016 275L</b>	: :																						
: :	<b>0031 335L</b>																						
<b>0025 284L</b>	<b>0032 623L</b>																						
<b>0026 525L</b>																							

No./Item	Description																				
02 REC LINE3	<p>This selects the additional line where the signals are to be recorded.</p> <table> <tr> <td>[525i system]</td> <td>[625i system]</td> </tr> <tr> <td><b>0000 10L</b></td> <td><b>0000 7L</b></td> </tr> <tr> <td>: :</td> <td>: :</td> </tr> <tr> <td><b>0003 13L</b></td> <td><b>0003 10L</b></td> </tr> <tr> <td>: :</td> <td>: :</td> </tr> <tr> <td><b>0012 22L</b></td> <td><b>0015 22L</b></td> </tr> <tr> <td><b>0013 263L</b></td> <td><b>0016 320L</b></td> </tr> <tr> <td>: :</td> <td>: :</td> </tr> <tr> <td><b>0025 284L</b></td> <td><b>0032 623L</b></td> </tr> <tr> <td><b>0026 525L</b></td> <td></td> </tr> </table> <p><b>Note:</b> This menu option is not displayed when setting “1” has been selected as the additional line mode.</p>	[525i system]	[625i system]	<b>0000 10L</b>	<b>0000 7L</b>	: :	: :	<b>0003 13L</b>	<b>0003 10L</b>	: :	: :	<b>0012 22L</b>	<b>0015 22L</b>	<b>0013 263L</b>	<b>0016 320L</b>	: :	: :	<b>0025 284L</b>	<b>0032 623L</b>	<b>0026 525L</b>	
[525i system]	[625i system]																				
<b>0000 10L</b>	<b>0000 7L</b>																				
: :	: :																				
<b>0003 13L</b>	<b>0003 10L</b>																				
: :	: :																				
<b>0012 22L</b>	<b>0015 22L</b>																				
<b>0013 263L</b>	<b>0016 320L</b>																				
: :	: :																				
<b>0025 284L</b>	<b>0032 623L</b>																				
<b>0026 525L</b>																					
03 REC LINE4	<p>This selects the additional line where the signals are to be recorded.</p> <table> <tr> <td>[525i system]</td> <td>[625i system]</td> </tr> <tr> <td><b>0000 10L</b></td> <td><b>0000 7L</b></td> </tr> <tr> <td>: :</td> <td>: :</td> </tr> <tr> <td><b>0012 22L</b></td> <td><b>0015 22L</b></td> </tr> <tr> <td><b>0013 263L</b></td> <td>: :</td> </tr> <tr> <td>: :</td> <td><b>0019 323L</b></td> </tr> <tr> <td><b>0017 276L</b></td> <td>: :</td> </tr> <tr> <td>: :</td> <td><b>0031 335L</b></td> </tr> <tr> <td><b>0025 284L</b></td> <td><b>0032 623L</b></td> </tr> <tr> <td><b>0026 525L</b></td> <td></td> </tr> </table> <p><b>Note:</b> This menu option is not displayed when setting “1” has been selected as the additional line mode.</p>	[525i system]	[625i system]	<b>0000 10L</b>	<b>0000 7L</b>	: :	: :	<b>0012 22L</b>	<b>0015 22L</b>	<b>0013 263L</b>	: :	: :	<b>0019 323L</b>	<b>0017 276L</b>	: :	: :	<b>0031 335L</b>	<b>0025 284L</b>	<b>0032 623L</b>	<b>0026 525L</b>	
[525i system]	[625i system]																				
<b>0000 10L</b>	<b>0000 7L</b>																				
: :	: :																				
<b>0012 22L</b>	<b>0015 22L</b>																				
<b>0013 263L</b>	: :																				
: :	<b>0019 323L</b>																				
<b>0017 276L</b>	: :																				
: :	<b>0031 335L</b>																				
<b>0025 284L</b>	<b>0032 623L</b>																				
<b>0026 525L</b>																					
802 TELETEXT SEL (For AJ-SPD850P)	<p>This selects the type of teletext signals to be recorded.</p> <p><b>0000 MOJI :</b> MOJI system</p> <p><b>0001 NABTS :</b> NABTS system</p> <p><b>Notes:</b></p> <ul style="list-style-type: none"> <li>•This menu option is not displayed in the 625i system.</li> <li>•VITC signals are often mistakenly detected as teletext signals when the NABTS system has been selected. If this happens, select MANU as the setting for setup menu No. 803 (TELETEXT DET), then select the line for teletext signals.</li> </ul>																				

The underlined items indicates the initial setting.

# Setup menus (continued)

## ■ USER menu <V BLANK>

No./Item	Description
803 TELETEXT DET	<p>This selects the method used to detect the lines in which the teletext signals are to be recorded.</p> <p><u>0000 OFF</u> : The teletext signals are not recorded.</p> <p>0001 <u>AUTO</u> : The teletext signals are automatically detected and recorded.</p> <p>0002 <u>MANU</u> : The lines in which the teletext signals are to be recorded are selected and set.</p> <p><b>Notes:</b></p> <ul style="list-style-type: none"> <li>•The number of lines in which the teletext signals can be recorded depends on the number of recording lines which was entered as the setup menu No. 800 (ADD LINE 25) or No. 801 (ADD LINE 50) setting. [See "Number of lines which can be set for TELETEXT."] ]</li> <li>•When setting "MANU" is selected and the STOP button is pressed, operation transfers to the sub-screen, and the number of recording lines can be selected. To return from the sub-screen, press the STOP button again.</li> <li>•When the input signal is a non-standard signal or N-STD has been selected for the setup menu No. 303 (STD/NON-STD) setting, teletext signals will not be played back correctly in EE mode.</li> </ul>
<b>Sub-screen</b>	
[525i system] 00 REC LINE1 : 12 REC LINE13	<p>This selects the lines in which the teletext signals are to be recorded.</p> <p>[525i system]      [625i system] <u>0000 OFF</u>      <u>0000 OFF</u> 0001 10&amp;273      0001 7&amp;320 0002 11&amp;274      0002 8&amp;321 0003 12&amp;275      0003 9&amp;322 [625i system] 00      0004 13&amp;276      0004 10&amp;323 REC LINE1      0005 14&amp;277      0005 11&amp;324 : 14      0006 15&amp;278      0006 12&amp;325 REC LINE15      0007 16&amp;279      0007 13&amp;326 0008 17&amp;280      0008 14&amp;327 0009 18&amp;281      0009 15&amp;328 0010 19&amp;282      0010 16&amp;329 0011 20&amp;283      0011 17&amp;330 0012 21&amp;284      0012 18&amp;331 0013      22      0013 19&amp;332 0014 20&amp;333 0015 21&amp;334 0016      22</p>

No./Item	Description
804 BLANK LINE	<p>This turns the blanking ON or OFF in the vertical blanking period of the video output signals.</p> <p><u>0000 BLANK</u> : Blanking is effected forcibly for all lines.</p> <p>0001 <u>THRU</u> : No blanking is effected for any of the lines.</p> <p>0002 <u>MANU</u> : Blanking ON or OFF is selected for each line.</p> <p><b>Note:</b> When setting "MANU" is selected and the STOP button is pressed, operation transfers to the subscreen, and ON or OFF can be selected for each line. To return from the sub-screen, press the STOP button again.</p>
<b>Sub-screen</b>	
[525i system] 00 LINE 10&273 : 11 LINE 21&284	<p><u>0000 BLANK</u> : Blanking is forcibly effected.</p> <p>0001 <u>THRU</u> : No blanking is effected.</p>
[625i system] 00 LINE 7&320 : 15 LINE 22&335	

The underlined items indicates the initial setting.

## Setup menus (continued)

### ■ USER menu <V BLANK>

Number of lines which can be set for TELETEXT

•When 25 Mbps is the recording/playback format.

No. 800: ADD LINE 25 setting value	Number of lines which can be set			
	[525i system]		[625i system]	
	660: UMID REC setting value		660: UMID REC setting value	
	OFF	ON	OFF	ON
OFF	13	10	14	12
YC422	5	4	7	5
YC411	8	5	10	8
Y1_B/W	13	10	14	12
Y1_BPF				
C1				
Y2_B/W	5	4	7	5
Y2_BPF				
C2				

•When 50 Mbps is the recording/playback format.

No. 801: ADD LINE 50 setting value	Number of lines which can be set			
	[525i system]		[625i system]	
	660: UMID REC setting value		660: UMID REC setting value	
	OFF	ON	OFF	ON
OFF	10	9	15	12
YC422				
Y4_B/W				
Y4_BPF				
C4				

No./Item	Description
900  LCD PROTECT	<p>Sets LCD protect mode.</p> <p><b>0000 OFF</b> : LCD protect mode is off. <b>0001 ON</b> : LCD protect mode is on.</p> <p><b>Notes:</b></p> <ul style="list-style-type: none"> <li>•If no operations are performed on the front panel, or if the video is not updated for some length of time, LCD output is turned off after approximately five minutes.</li> <li>•To turn off LCD protect mode, operate a button or dial on the front panel, or start playback through the controller. Note that the operation performed to turn off LCD protect mode will be executed.</li> </ul>
901  BL BRIGHT	<p>This sets the brightness of the LCD's backlight.</p> <p><b>0000 NORMAL:</b> The backlight lights at the normal brightness level. <b>0001 HIGH:</b> The backlight lights brightly.</p>
902  GUI OUTPUT	<p>This sets whether to output the GUI screen display to the ANALOG COMPONENT VIDEO OUT, ANALOG COMPOSITE VIDEO OUT and SERIAL DIGITAL COMPONENT VIDEO OUT connectors.</p> <p><b>0000 OFF:</b> The screen display is not output. <b>0001 ON:</b> The screen display is output.</p>
903  P.ON GUI	<p>This sets whether to display the thumbnail screen when the power is turned on.</p> <p><b>0000 OFF:</b> The thumbnail screen is not displayed. <b>0001 THUMB:</b> The thumbnail screen is displayed.</p>

The underlined items indicates the initial setting.



## Setup menus (continued)

### ■ USER menu <MENU>

No./Item	Description
<b>A00</b> <b>LOAD</b>	<p>This selects the user file whose contents will be loaded into USER1.</p> <p><u>0000</u> <b>USER2</b> : The USER2 file contents are loaded.</p> <p>0001 <b>USER3</b> : The USER3 file contents are loaded.</p> <p>0002 <b>USER4</b> : The USER4 file contents are loaded.</p> <p>0003 <b>USER5</b> : The USER5 file contents are loaded.</p> <p><b>Note:</b> When the SET button is pressed after loading, the setting will be stored in the memory. When the MENU button is pressed, the setting will not be changed.</p>
<b>A01</b> <b>SAVE</b>	<p>This selects the user file into which the USER1 settings will be saved.</p> <p><u>0000</u> <b>USER2</b> : The settings are saved in USER2.</p> <p>0001 <b>USER3</b> : The settings are saved in USER3.</p> <p>0002 <b>USER4</b> : The settings are saved in USER4.</p> <p>0003 <b>USER5</b> : The settings are saved in USER5.</p> <p>0004 <b>LOCKED</b> : This display appears when all the user files are in the change prohibit status.</p> <p><b>Notes:</b></p> <ul style="list-style-type: none"> <li>•User files whose status have been set to change prohibit cannot be selected.</li> <li>•When all the user files are in the change prohibit status, the "LOCKED" display appears and the contents cannot be saved.</li> </ul>

No./Item	Description
<b>A02</b> <b>P. ON LOAD</b>	<p>This loads the contents of the selected user file into USER1 and it starts operation with the USER1 settings when the power is turned on.</p> <p><u>0000</u> <b>OFF</b> : Operation is started with the settings of the previously set user file.</p> <p>0001 <b>USER2</b> : The contents of USER2 are loaded into USER1 and operation is started with the USER1 settings.</p> <p>0002 <b>USER3</b> : The contents of USER3 are loaded into USER1 and operation is started with the USER1 settings.</p> <p>0003 <b>USER4</b> : The contents of USER4 are loaded into USER1 and operation is started with the USER1 settings.</p> <p>0004 <b>USER5</b> : The contents of USER5 are loaded into USER1 and operation is started with the USER1 settings.</p>
<b>A03</b> <b>MENU LOCK</b>	<p>This selects whether to set or release the user file (USER2-USER5) lock mode.</p> <p><u>0000</u> <b>OFF</b> : The lock is released (changes can be made).</p> <p>0001 <b>ON</b> : The lock is set (changes are prohibited).</p> <p><b>Note:</b> The lock cannot be set for USER1.</p>

#### Notes:

- No. A00 (LOAD), No. A01 (SAVE) and No. A02 (P. ON LOAD) are the menu items which can be set only for USER1. They are not displayed with the USER2-USER5 files.
- No. A03 (MENU LOCK) is the menu item which can be set only for the USER2-USER5 files. It is not displayed with USER1.

The underlined items indicates the initial setting.

# Time code, user bit and CTL

## Time code

The time code is used when the time code signal generated by the time code generator (time code signal generator) is to be recorded.

The time code values are indicated using the display and superimpose functions.

TCR 00 : 07 : 04 : 24  
↑     ↑     ↑     ↑  
Hours Minutes Seconds Frames

## User bit

“User bit” refers to the 32-bit (8-digit) data frame among the time code signals which has been released to users. It enables operator numbers values to be recorded.

The alphanumeric characters which can be used for the user bit are the figures 0 to 9 and the letters A to F.

## Setting the internal time code

- (1) Set the memory card recorder to stop mode
- (2) Select “TC” using the COUNTER button
- (3) Set the run mode for the time code generator using the TC REC RUN/FREE RUN switch

### REC:

The internal time code generator is advanced during recording.

### FREE:

When the power is on, the internal time code generator is advanced regardless of the operation mode.

- (4) Set the TCG switch to REGEN mode

### REGEN:

In this mode, the continuity of the original time code prior to editing is maintained.

### PRESET:

In this mode, recording is commenced from the value which was set by the TC PRESET button.

- (5) Use the TC PRESET button to set the start number of the time code or user bit

- ① Press the TC PRESET button. The left-most set of digits starts flashing.
- ② To change the value, turn the search dial while holding down the SEARCH button.
- ③ Turn the search dial to select the set of digits that is to be set. The digits selected start flashing.

The setting ranges are as follows:

#### •Time code:

[525i system]

00:00:00:00 to 23:59:59:29

[625i system]

00:00:00:00 to 23:59:59:24

#### •User bit:

00:00:00:00 to FF FF FF FF

- ④ Repeat steps ② and ③ to change any other values.
- ⑤ Once the start number has been set, press the SET button.  
In the FREE RUN mode, the time code begins to advance.
- ⑥ Proceed with the recording.

## Setting the external time code

- (1) Set the memory card recorder to stop mode
- (2) Select “TC” using the COUNTER button
- (3) Set the TCG switch to EXT. (External time code selection)
- (4) The following settings can be selected with setup menu No. 505 (EXT TC SEL)

### LTC:

The LTC signal input to the TIME CODE IN connector (XLR) on the rear panel is recorded as TC.

### Note:

LTC must be synchronized with the video signal.

### VITC:

The VITC of the input video signal is recorded as TC.

## Reproducing the time code/user bit

- (1) Set the memory card recorder to stop mode
- (2) Select “TC” or “UB” using the COUNTER button
- (3) Press the PLAY button

Playback starts and the time code is shown on the display.

When the SUPER switch is set to ON, the time code value is superimposed on the video signals from the VIDEO OUT 3/SDI OUT 3 connector (optional).

T \* R 00:01:04:07\*

When the time code signal cannot be read, an asterisk (\*) is displayed.

“ ”: 1, 3 field  
“ \* ”: 2, 4 field

The colon between the seconds and frames changes to a period during drop frame mode.

## CTL mode

- (1) Set the memory card recorder to the stop mode
- (2) Select “CTL” using the COUNTER button

During playback, the counter displays the play position as relative to the start.

During recording, the counter value starts from [0:00:00:00]. If the MODE switch is at the PB setting when recording ends, the position relative to the start will be displayed.



# Video output signals and servo reference signal

This section explains how the output signals and servo reference signal are selected.

## External synchronization of video output signals

The video output signals are output in synchronization with the REF VIDEO input signal or video input signal.

As shown in the figure below, this signal is selected in accordance with the setup menu settings, deck mode and availability of the video input signal.

## Notes:

Synchronization is determined as follows depending on the availability of the REF VIDEO input signal when “BB”, “CB100” or “CB75” has been selected as the setup menu No. 600 (INT SG) setting.

- When the REF VIDEO input signal is available:  
Synchronization with the REF VIDEO input signal
- When the REF VIDEO input signal is not available:  
Internal synchronization

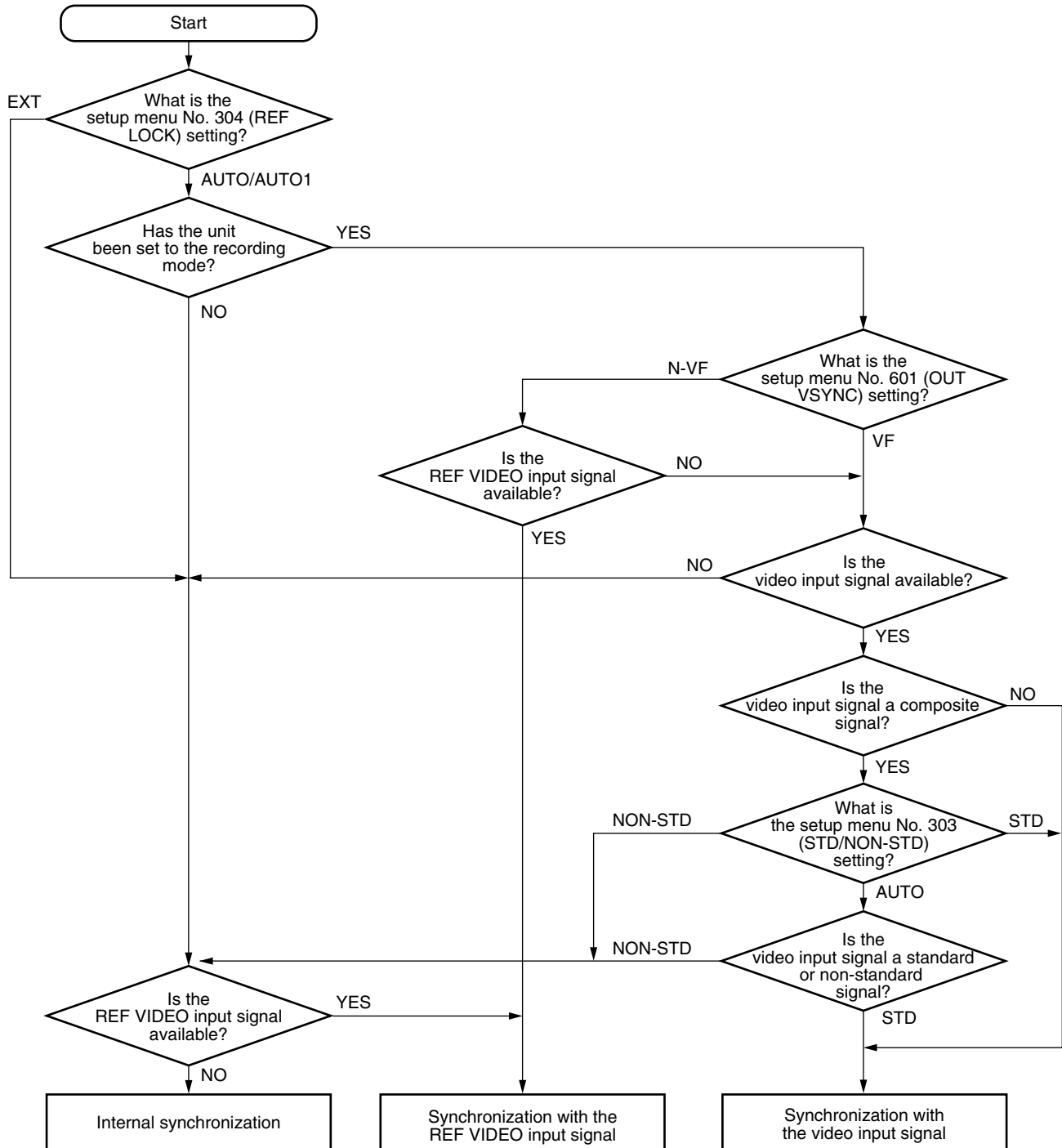

# Audio V fade function

When the settings below are selected for audio processing between clips or events (setup menu No.727: PB FADE) at times such as during clip selection and playback or play list playback, V fade or cut processing is performed for these sections during playback.

The clips recorded over a multiple number of P2 cards and the clips created by edit copying are shown in the figure below.

Clips extending over more than one P2 card or automatically divided and recorded clips using a P2 card with a memory capacity of 8 GB or more

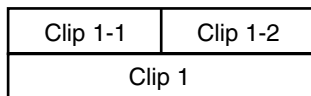

Clip created by edit copying

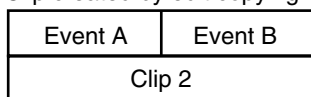

Described below is an example where the above two types of clips are to be played back using the play list function.

## •When CUT is selected

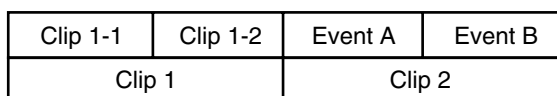

Noise appears at the edit splice.

## •When FADE is selected

V fade processing is performed for all the sections between clips and between the events of edit-copied clips.

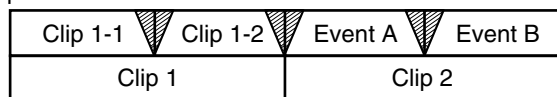

V fade is performed instantaneously between all clips and events to reduce noise.

## •When AUTO has been selected

V fade is automatically performed except between events when clips extending over more than one P2 card or clips automatically divided and recorded using a P2 card with a memory capacity of 8 GB or more have been registered on a play list.

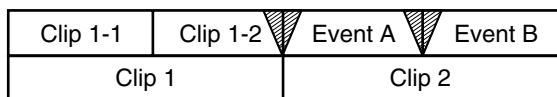

V fade is performed instantaneously to eliminate the noise.

## Note:

This setting takes effect only when the power is on.

# Audio recording channel and monitor output selection

## ■ Audio recording channel

The audio is selected as shown below by using the AUDIO MIX switch, REC CH1/CH3 and REC CH2/CH4 buttons on the front panel.

Recording track	Recording signal
<b>CH1</b>	CH1 input/CH2 input/CH1 input+CH2 input
<b>CH2</b>	CH1 input/CH2 input/CH1 input+CH2 input
<b>CH3</b>	CH3 input/CH4 input/CH3 input+CH4 input
<b>CH4</b>	CH3 input/CH4 input/CH3 input+CH4 input

## ■ Monitor output channel

The monitor output channels are selected using the MONITOR SELECT and MONITOR MIX button as shown below.

Monitor output	Output signal
<b>L</b>	CH1/CH2/CH3/CH4/CH1+CH2/CH3+CH4/ CH1+CH3/CH2+CH4
<b>R</b>	CH1/CH2/CH3/CH4/CH1+CH2/CH3+CH4/ CH1+CH3/CH2+CH4

# Printed circuit board

## F1 board (AUDIO)

Switch No.	Function
<b>SW100</b>	<b>AUDIO INPUT IMPEDANCE SW</b> This sets the CH1 audio input impedance. <u>HIGH/600Ω</u>
<b>SW101</b>	<b>AUDIO INPUT IMPEDANCE SW</b> This sets the CH2 audio input impedance. <u>HIGH/600Ω</u>
<b>SW200</b>	<b>AUDIO INPUT IMPEDANCE SW</b> This sets the CH3 audio input impedance. <u>HIGH/600Ω</u>
<b>SW201</b>	<b>AUDIO INPUT IMPEDANCE SW</b> This sets the CH4 audio input impedance. <u>HIGH/600Ω</u>

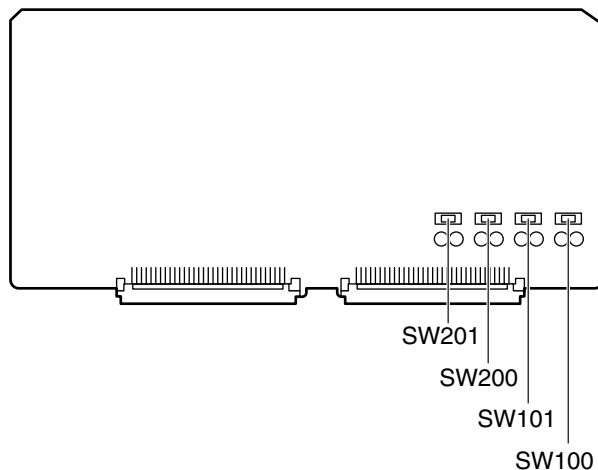

The underlined items indicates the initial setting.

# Rack mounting

The memory card recorder can be mounted into a 19-inch standard rack using the optional rack-mounting adaptors (AJ-MA75P).

For the installation rails, it is recommended that the 18-inch rail and bracket (model number CC3061-99-0400) by Chassis Trak be used. (The complete slide rail and bracket deck is not available from Panasonic.)

For further details, consult your dealer.

## (1) Attach the inner members of the slide rails

Refer to the figure below for the locations where the screws are to be attached.

Locations where the screws are secured on the right (R) side of the inner members of the slide rails

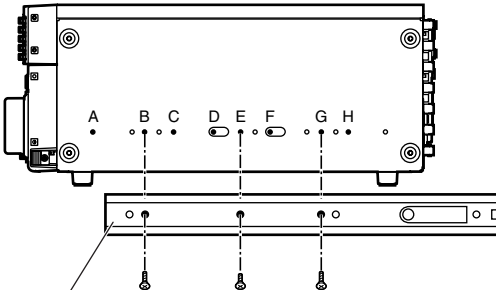

Inner member

### Notes:

- The length of the screws used is subject to restriction. (B, H: 10 mm, F: 6 mm)
- Attach the inner members at the same symmetrical positions on the left (L) side.
- Fix the members in place using 3 screws on each side (total: 6 screws).
- The letters "A" to "H" are not actually marked on the side panels.

## (2) Attach the outer member brackets to the rack

Check that the height is the same for the left and right brackets.

## (3) Remove the four screws at the front for attaching the left and right side panels

## (4) Attach the AJ-MA75P rack mount adaptor using the removed 4 screws

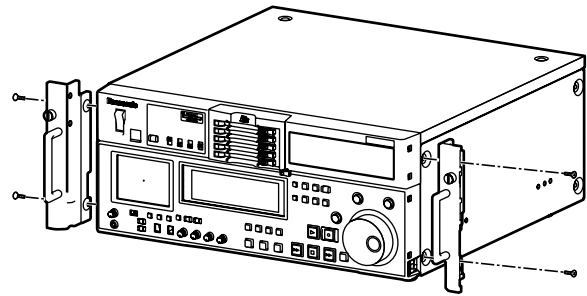

Rack-mounting adaptors

## (5) Remove the 4 rubber legs from the bottom of the memory card recorder, and install the memory card recorder in the rack

After the memory card recorder has been installed, check that it moves smoothly along the rails.

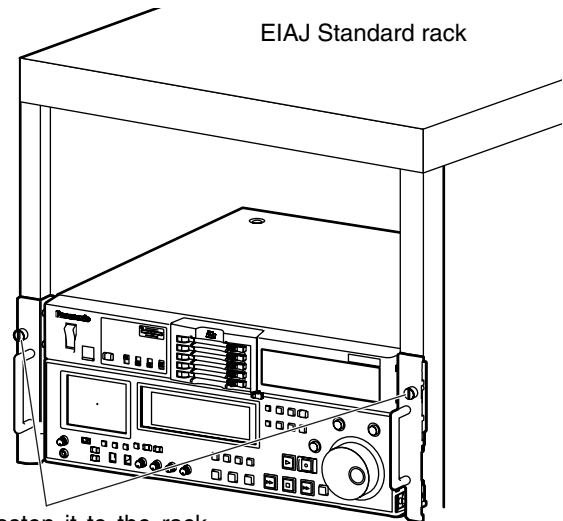

Fasten it to the rack with set screws.

### Notes:

- Keep the temperature inside the rack from 41°F to 104°F (5°C to 40°C).
- Bolt the rack securely to the floor so that it will not topple over when the memory card recorder is drawn out.

# Condensation

---

Condensation occurs due to the same principle involved when droplets of water form on a window pane of a heated room. It occurs when the deck or card is moved between places where the temperature or humidity varies greatly or when, for instance:

- It is moved to a very humid place full of steam or a room immediately after it has been heated up.
- It is suddenly moved from a cold location to a hot or humid location.

When moving the deck to locations such as these, leave it standing for about 10 minutes rather than switching on the power immediately.

# Maintenance

---

Before starting any maintenance work, switch the power to OFF and, holding the plug, unplug the cord from the socket.

Use a soft cloth to clean the outside of the deck.

For stubborn dirt or stains, wipe the deck with a cloth that has been lightly dampened with well-diluted kitchen detergent and wrung out thoroughly.

After wiping off the dirt with the damp cloth, finish it off with a dry cloth.

**Note:**

Do not use alcohol, benzene, thinners or any other solvents as they may affect the color of external parts or damage the deck's coating.



# Error messages

When a warning occurs in this unit, the error number is indicated on the counter display.

Open the DIAG menu to display a description of the error on the counter display or monitor TV. When an operational malfunction has occurred in the unit, the error number flashes on the counter display.

## DIAG menu

This displays the deck information.

Deck information includes "WARNING" information, "HOURS METER" (usage time) information and "UMID (Unique Material Identifier)" information.

A DIAG menu appears on the monitor when the monitor is connected to the VIDEO OUT 3/SDI OUT 3 connector (optional) on the rear panel.

## Displaying the DIAG menu

### (1) Press the DIAG button.

The DIAG menu screen is displayed on the monitor, and the message is displayed on the counter display.

### (2) Press the SEARCH button.

Each time the button is pressed, the display changes as follows: "WARNING", "HOURS METER", "UMID INFO" and so on.

Press the DIAG button again to return to the original display.

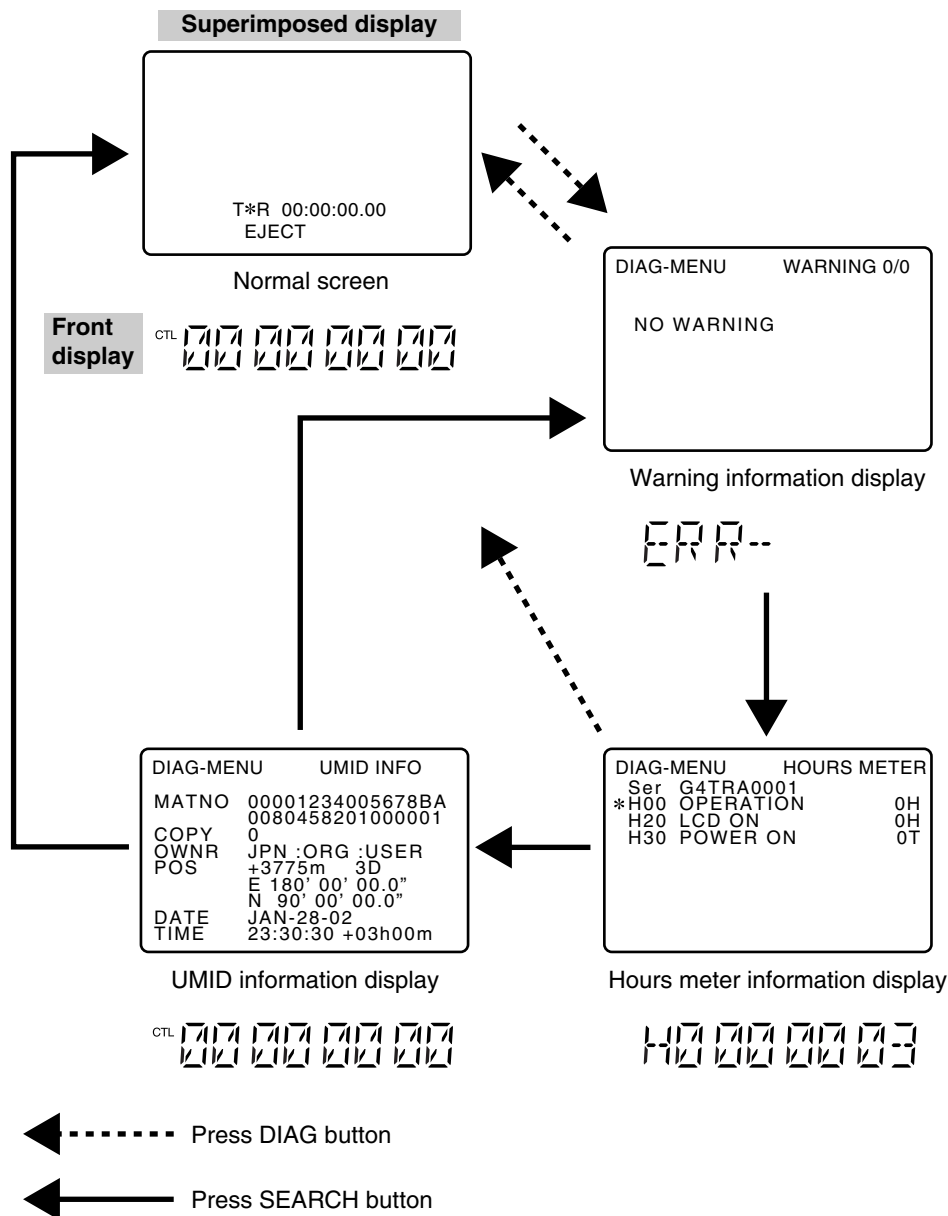

## Error messages (continued)

### ■ “WARNING” information display

- A warning message is displayed whenever a warning occurs.  
When warnings have not been detected, “NO WARNING” is displayed.
- When multiple warnings occur, the descriptions for each warning can be checked by turning the search dial.  
If “T&S&M” is selected in the setup menu No. 008 (DISPLAY SEL), a message appears in the mode display whenever a warning or error occurs.  
When multiple events occur, the event with the highest priority is displayed.

### Warning messages

Priority	Monitor display	Description	Deck operation	Counter display
high  low	<b>BUSY</b>	Displayed while the clip information is being read or when the clip configuration has changed. No operations can be performed while this display is on the screen. [Meaning] <ul style="list-style-type: none"> <li>• A card has been inserted or removed.</li> <li>• Updating is now underway.</li> <li>• Processing is now underway after recording.</li> <li>• Other</li> </ul>	operation continues	<b>BUSY</b>
	<b>CANNOT REC</b>	Displayed when data cannot be recorded on the P2 card. [Meaning] <ul style="list-style-type: none"> <li>• An attempt has been made to record data when the card is write-protected.</li> <li>• An attempt has been made to record data when the card has no more free memory space on it.</li> <li>• An attempt has been made to record on a card that cannot be used.</li> <li>• The card status has changed during recording.</li> </ul>	stop	<b>CANT REC</b>
	<b>CANNOT PLAY</b>	Displayed when play has been stopped by clip trouble or other factors. [Meaning] <ul style="list-style-type: none"> <li>• An attempt has been made to play clips when there are no clips present.</li> <li>• An attempt has been made to initiate play for a card that cannot be used.</li> <li>• Play is not acknowledged or it has been stopped for some other reason.</li> </ul>	stop	<b>CANT PLAY</b>
	<b>INT SG</b>	Displayed for the first two seconds when the REC button is pressed and the E-E mode is established while SG, SG1 or SG2 has been selected using the INPUT SELECT VIDEO button or while SG has been selected using the INPUT SELECT AUDIO button.	operation continues	<b>INT SG</b>
	<b>NO INPUT</b>	Displayed for the first two seconds when the REC button is pressed and the E-E mode is established while no input signals except for analog audio signals are being supplied to the connector selected using the INPUT SELECT button.	operation continues	<b>NO INPUT</b>
	<b>MARK ON / MARK OFF</b>	Displayed for two seconds when a shot mark has been added or deleted.	operation continues	<b>MARK ON/ MARK OFF</b>

## Error messages (continued)

If "E- \* \*" lights up in the monitor display, the contents are displayed when the DIAG-MENU is opened.

Priority	Monitor display		Description	Deck operation
	No.	Message		
high  low	E-21	REC WARNING	Displayed when trouble has occurred in the video or audio during recording. To continue operation, turn the power off and then back on.	stop
	E-26	CARD ERR xx	Displayed when a data error caused by a P2 card has occurred during recording. It remains displayed even after recording has stopped until the next operation is performed. No display appears when an error has occurred during playback. ("xx" denotes the slot number where the error occurred.) Replace the P2 card in the slot where the error occurred.	stop
	E-25	IRREGULAR CLIP	Displayed when there is an irregular clip. Recording can be continued even while this message is displayed, but the clip should be fixed if, for example, it is necessary to regenerate the time code. After fixing the clip, turn the power off and then back on before proceeding with the next operation.	operation continues
	E-10	FAN STOP	Displayed when the fan motor has stopped. Check the fan motor for foreign matter or objects.	operation continues

### Error messages

Error		Description	Deck operation
No.	Message		
E-30	TURN POWER OFF	Displayed when trouble has occurred in reading data from the card or writing data onto the card. To continue operation, turn the power off and then back on.	stop
E-37	COMM ERROR	Displayed when the orders issued by the system control command have not been followed even after 3 seconds have elapsed. To continue operation, turn the power off and then back on.	stop
E-38	SYSTEM ERROR	Displayed when trouble has occurred in communication. To continue operation, turn the power off and then back on.	stop
E-50	BATTERY EMPTY	Displayed when a drop in the voltage of the internal clock's backup battery has been detected while the power is on. Replace the internal battery.	operation continues
E-61	DVD DRIVE ERROR	Displayed when trouble has occurred in the DVD drive unit connection or control. When a DVD drive unit is not connected, set the DVD setting to [DISABLE]. When a DVD drive unit is connected, refer to the operating instructions of the DVD drive unit.	stop

#### Note:

- "E-50" appears when the backup battery has no more charge. After consulting with your dealer, replace it with a new battery (CR2032 or its equivalent). After replacing the battery, be absolutely sure to set the deck's internal clock using setup menu No. 069 (CLOCK SET).

## Error messages (continued)

### ■ Error information in LAN mode

No.	Message	Description
E-41	LAN NO LINK	Displayed when there is a problem in the LAN connections. Check the LAN connections. To continue operation, turn the power off and then back on.
E-43	DHCP TIMEOUT	Displayed when there is a problem in the connections with the DHCP server. Check the DHCP server settings. To continue operation, turn the power off and then back on.
E-49	LAN ERROR	Displayed when the LAN connection or disconnection has failed. To continue operation, turn the power off and then back on. Check the LAN settings and connections if E-49 appears again.

### ■ “HOURS METER” information display

Turn the search dial to move the cursor (\*). The description for the item where the cursor is located is shown on the counter display.

No.	Item	Description	Counter display
Ser	* * * * *	Displays the deck's serial No.	
H00	OPERATION	Displays the time that the power has been supplied in one-hour units.	0H - 99999H
H20	LCD ON	Displays the time during which the LCD monitor has been lighted in 1-hour increments.	0H - 99999H
H30	POWER ON	The number of times the power has been turned on is displayed in single units.	0T - 99999T

#### Notes:

- The resettable items in the “HOURS METER” information are reset by the shop when performing maintenance or other work.
- The search buttons and the search dial cannot be operated while the DIAG menu is displayed.

# RS-232C interface

The memory card recorder can be operated by commands when the RS-232C interface is used.  
(See command table on pages 75, 76)

## ■ Conditions for acknowledging commands from RS-232C interface

- The front panel REMOTE button is lit
  - The setup menu No. 204 (RS232C SEL) must be ON.
- If the above conditions are not met, [ACK] + [STX] ER001 [EXT] is returned to the external deck.
- Whether the [ACK] code is returned depends on the setting which has been selected for setup menu item No. 209 (RETURN ACK).

## ■ Hardware specifications

### External interface specifications

- Connector specifications
- Connector:  
D-SUB 25-pin (crossover cable supported)

Pin No.	Signal	Description
1	FG	Protective ground (Frame ground)
2	RXD	Received data (Data is sent to PC.)
3	TXD	Transmitted data (Data is received from PC.)
4	CTS	Clear to send (Shorted with pin 5.)
5	RTS	Request to send (Shorted with pin 4.)
6	DTR	Data terminal ready (No processing)
7	SG	Signal ground (Signal ground)
20	DSR	Data set ready (+ voltage output after communication enable status)

- Example of connection with controller (PC)  
(Using crossover cable with D-SUB 25-pin connectors)

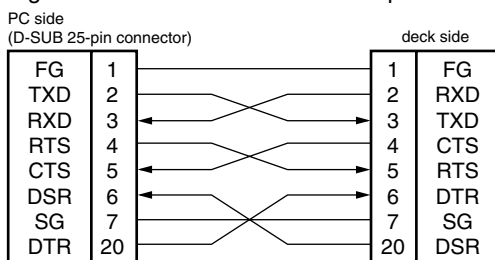

- (Using crossover cable with D-SUB 9-pin and 25-pin connectors)

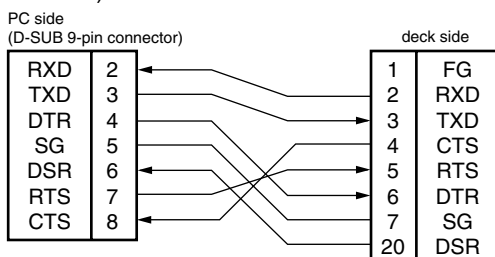

## ■ Software specifications (Protocol)

### Communication parameters

Communication system	Asynchronous, full duplex
Communication speed	300/600/1200/2400/4800/9600
Bit length	7bit/8 bit
Stop bit	1 bit/2 bit
Parity bit	NONE/ODD/EVEN
ACK code	ACK code returned/ACK code not returned <b>Note:</b> The ACK code is what is returned from the memory card recorder to the controller when data has been successfully sent from the controller.

The underlining indicates the factory settings.

Any changes to the settings can be made using the setup menu items listed below.

Communication parameter	Setup menu item
Communication speed	No.205 BAUD RATE
Bit length	No.206 DATA LENGTH
Stop bit	No.207 STOP BIT
Parity bit	No.208 PARITY
ACK code	No.209 RETURN ACK

### Send format

[controller (PC) → memory card recorder]

### Data format

[STX] [command] [:] [data] [ETX]  
02h XX XX XX 3Ah XX.....XX 03h

### 20H<XX<7FH

(XX = ASCII code: symbols, numbers upper-case letters)

[command] :

Command identifier; a 3-byte identifier (ASCII code: symbols, numbers, upper-case letters) is sent as the command.

[:]

This code serves as a delimiter between the command and data.

[data] :

Data (ASCII code: symbols, numbers, uppercase letters) can be added in the number of bytes required.

### Outline of send procedure from controller

- The send command starts with STX (start of text = 02h). The command is then identified by COMMAND which follows and the data is added as required. The format ends with ETX (end of text = 03h).
- When a different command is to be sent, a response is awaited from the memory card recorder, and then the command is sent.
- If STX is sent again before ETX is sent, the receive data buffer inside the memory card recorder is cleared. A command error is returned to the controller, and the data is newly processed with STX which was received again at the head.

# RS-232C interface (continued)

## Return format

[memory card recorder → controller (PC)]

The following responses are made to the command. If necessary, more than one response is made.

### When the communication has terminated normally

- ① The receive completion message is returned.

**[ACK]**

06h

- ② The execution completion message is returned.

**[STX] [command] [data] [ETX]**

02h XX XX XX XX.....XX 03h

[command] :

This is the message (data) which is returned or the execution completion message identifier.

[data] :

This is the data to be returned. It can be omitted.

Example :

Send command      Return message (data)

[STX] OPL [ETX] → [ACK] [STX] OPL [ETX]

### When the communication has terminated abnormally

**[NACK]**

15h

### When processing is not possible due to incorrect data or trouble in the memory card recorder

- ① The receive completion message is returned.

**[ACK]**

06h

- ② An error code is returned.

**[STX] [ERN<sub>1</sub> N<sub>2</sub> N<sub>3</sub>] [ETX]**

02h Error code 03h

## Error code table

- ER001** : Invalid command
- Unsupported command received.
  - Error in command execution
- ER002** : Parameter error
- ER1FF** : Deck system error

## Command table

### Commands relating to operation control

#### Notes:

- As for the return (completion) message, [ACK] is first returned when data is received, and the execution message is subsequently returned. It is only the execution message which is listed in this table.
- In the case of commands not listed in the table, ER001 (invalid command) is returned after [ACK] has been returned.

Deck operation	Send command	Return (completion) message
STOP	[STX] OSP [ETX] ↔ [STX] OSP [ETX]	This command is for stopping the travel.
PLAY	[STX] OPL [ETX] ↔ [STX] OPL [ETX]	This command is for starting playback.

Deck operation	Send command	Return (completion) message
REWIND	[STX] ORW [ETX] ↔ [STX] ORW [ETX]	This command is for rewinding. The resulting output picture and sound statuses differ according to the settings selected for the setup menu No. 105 (AUTO EE SEL). The maximum speed differs according to the setting selected for setup menu No. 102 (FF. REW MAX). For details, see each setup menu.
FAST FORWARD	[STX] OFF [ETX] ↔ [STX] OFF [ETX]	This command is for fast forwarding. The resulting output picture and sound statuses differ according to the settings selected for the setup menu No. 105 (AUTO EE SEL). The maximum speed differs according to the setting selected for setup menu No. 102 (FF. REW MAX). For details, see each setup menu.
REC	[STX] ORC [ETX] ↔ [STX] ORC [ETX]	This command is for starting the recording.
SHTL FORWARD	[STX] OSF:data [ETX] ↔ [STX] OSF [ETX]	This is the forward direction shuttle command. data = n : speed data 0 : STILL 1 : × 0.03 2 : × 0.1 3 : × 0.2 4 : × 0.5 5 : × 1 6 : × 2 7 : × 4 8 : × 8 9 : × 16 A : × 32 <b>Note:</b> The x16 and x32 speed differ according to the setting selected for setup menu No. 101 (SHTL MAX).
SHTL REVERSE	[STX] OSR:data [ETX] ↔ [STX] OSR [ETX]	This is the reverse direction shuttle command. data = n : speed data 0 : STILL 1 : × 0.03 2 : × 0.1 3 : × 0.2 4 : × 0.5 5 : × 1 6 : × 2 7 : × 4 8 : × 8 9 : × 16 A : × 32 <b>Note:</b> The x16 and x32 speed differ according to the setting selected for setup menu No. 101 (SHTL MAX).

# RS-232C interface (continued)

## Commands relating to inquiries

### Notes:

- As for the return (completion) message, [ACK] is first returned when data is received, and the execution message is subsequently returned. It is only the execution message which is listed in this table.
- In the case of commands not listed in the table, ER001 (invalid command) is returned after [ACK] has been returned.

Deck operation	Send command	Return (completion) message
<b>CTL/TC DATA REQUEST</b>	[STX] QCD [ETX] ↔ [STX] CD data [ETX] This command is for inquiring about the counter value. data = f w gh mm ss ff f =F w =S gh = CTL mode: g = SP (20h) : for a plus display - (2Dh) : for a minus display h =0 – 9 : hours TC mode: gh = 00 – 23 : hours mm = 00 – 59 : minutes ss = 00 – 59 : seconds [525i system] ff = 00 – 29 : frames [625i system] ff = 00 – 24 : frames <b>Note:</b> CTL or TC is returned, whichever corresponds to the front display mode.	
<b>STATUS REQUEST</b>	[STX] QOP [ETX] ↔ [STX] * * * [ETX] This command is for inquiring about the memory card recorder's operation mode. * * * = OFF : FAST FORWARD OPL : PLAY ORC : REC ORW : REWIND OSP : STOP SRS : (IN/OUT) PREROLL OSF : SHTL FORWARD OSR : SHTL REVERSE OJG : JOG FORWARD/REVERSE OSW : VAR FORWARD/REVERSE	
<b>ID (deck No.) REQUEST</b>	[STX] QID [ETX] ↔ [STX] data [ETX] This command is for inquiring about the memory card recorder used. data = AJ-SPD850	

# Connector signals

## VIDEO IN

<b>SDI IN (DIGITAL)</b>	BNC × 2, Active through (Board, option)
<b>Y, PB, PR (ANALOG)</b>	BNC × 3 (Board, option)
<b>VIDEO IN</b>	BNC × 2, Loop-through, 75 Ω termination switch provided
<b>REF VIDEO IN</b>	BNC × 2, Loop-through, 75 Ω termination switch provided

## VIDEO OUT

<b>SDI OUT (DIGITAL)</b>	BNC × 3
<b>Y, PB, PR (ANALOG)</b>	BNC × 3
<b>VIDEO OUT</b>	BNC × 3

## AUDIO IN

<b>SDI IN (DIGITAL)</b>	BNC × 2, Active through
<b>AUDIO IN (DIGITAL)</b>	BNC × 2 (CH1/CH2, CH3/CH4) AES/EBU format
<b>AUDIO IN (ANALOG)</b>	XLR × 4 (CH1, CH2, CH3, CH4)
<b>TIME CODE IN</b>	XLR × 1

## AUDIO OUT

<b>SDI OUT (DIGITAL)</b>	BNC × 3
<b>AUDIO OUT (DIGITAL)</b>	BNC × 2 (CH1/CH2, CH3/CH4) AES/EBU format
<b>AUDIO OUT (ANALOG)</b>	XLR × 4 (CH1, CH2, CH3, CH4)
<b>TIME CODE OUT</b>	XLR × 1
<b>MONITOR OUT</b>	XLR × 2 (L/R)
<b>HEADPHONES (front)</b>	Stereo mini jack

## RS-422A REMOTE (9P)

(REMOTE)

Pin No.	Signal
1	FRAME GROUND
2	TRANSMIT A
3	RECEIVE B
4	RECEIVE COMMON
5	—
6	TRANSMIT COMMON
7	TRANSMIT B
8	RECEIVE A
9	FRAME GROUND

## RS-232C

D-SUB 25-pin (crossover cable supported)

Pin No.	Signal	Description
1	FG	Protective ground (Frame ground)
2	RXD	Received data (Data is sent to PC.)
3	TXD	Transmitted data (Data is received from PC.)
4	CTS	Clear to send (Shorted with pin 5.)
5	RTS	Request to send (Shorted with pin 4.)
6	DTR	Data terminal ready (No processing)
7	SG	Signal ground (Signal ground)
20	DSR	Data set ready (+ voltage output after communication enable status)

## ENCODER (15P)

Pin No.	Signal
1	—
2	BLACK LEVEL
3	C LEVEL
4	GND
5	+ 9V
6	SYSTEM H 0
7	SYS. SC COARSE (2)
8	– 9V
9	CHROMA PHASE
10	VIDEO LEVEL
11	RET GND
12	—
13	—
14	SYS. SC FINE
15	SYS. SC COARSE (1)



# Specifications

## GENERAL

**Power supply:** AC 100 – 240 V, 50 / 60 Hz  
**Power consumption:** 80 W, 105 W (with all options)

 indicates safety information.

**Operating ambient temperature:**

5 °C to 40 °C

**Operating ambient humidity:**

10 % to 80 % (no condensation)

**Mass:**

15 kg (30.8 lb)

**Dimensions (W x H x D):**

424 mm x 175.2 mm x 430 mm

(16 3/4 inches x 6 15/16 inches x 16 15/16 inches)

(Not including the support legs, connectors, and SEARCH dial)

**Recording format:**

DVCPRO50/DVCPRO/DV format selectable

**Recording video signal:**

525i/625i system selectable

**Recording audio signal:**

DVCPRO50 : 48 kHz 16-bit 4 channels

DVCPRO/DV : 48 kHz 16-bit 2/4 channels selectable

**Recording times:**

Card model	Number of Cards	Recording format	
		DVCPRO (2-channel audio)	DVCPRO50 (4-channel audio)
AJ-P2C002SG	1	approx. 8 minutes	approx. 4 minutes
	5	approx.40 minutes	approx.20 minutes
AJ-P2C004HG	1	approx.16 minutes	approx. 8 minutes
	5	approx.80 minutes	approx.40 minutes
AJ-P2C008HG	1	approx.32 minutes	approx.16 minutes
	5	approx.160 minutes	approx.80 minutes

**Note:**

All of the above times apply when single clips are recorded continuously one after the other on the P2 card.

Depending on the number of the clips to be recorded, the recordable time may be shorter than the times given above.

**Digital slow:**

-1.0x to +1.0x speed

## VIDEO

■ **Digital video**

**Sampling frequencies:**

Y: 13.5 MHz, P<sub>B</sub>/P<sub>R</sub>: 6.75 MHz (DVCPRO50)

**Quantizing:**

8 bits

**Video compression method:**

DV-Based compression (SMPTE 314M)

**Video compression rate:**

DVCPRO50: 1/3.3

DVCPRO : 1/5

**Error correction:**

Reed-Solomon product code

**Bit rate:**

DVCPRO50: 50 Mbps

DVCPRO : 25 Mbps

■ **Component IN/component OUT**

**Video bandwidth:**

For AJ-SPD850P

Y : 30 Hz to 5.75 MHz (-2.0 dB)

P<sub>B</sub>/P<sub>R</sub> : 30 Hz to 2.75 MHz (-2.0 dB)

For AJ-SPD850E

Y : 25 Hz to 5.75 MHz (-2.0 dB)

P<sub>B</sub>/P<sub>R</sub> : 25 Hz to 2.75 MHz (-2.0 dB)

**S/N ratio:** Better than 55 dB

**K factor:** Less than 1 % (Y 2T)

**Y/C delay:** Less than 20 nsec

■ **Composite IN/composite OUT**

**Video bandwidth:**

For AJ-SPD850P

Y : 30 Hz to 5.5 MHz (-3.0 dB)

For AJ-SPD850E

Y : 25 Hz to 5.5 MHz (-3.0 dB)

**Y/C delay:** Less than 20 nsec

■ **Video input connector**

**Analog component input:**

BNC x 3 (Y, PB, PR)

Y : 1.0 V [p-p], 75 Ω

For AJ-SPD850P

P<sub>B</sub>/P<sub>R</sub> : 0.486 V/0.7 V [p-p] selectable

75 Ω (75 % color bar, setup level 7.5 %)

For AJ-SPD850E

P<sub>B</sub>/P<sub>R</sub> : 0.7 V [p-p]

75 Ω (100 % color bar)

**Analog composite input:**

BNC x 2, loop-through, 75 Ω on/off

VIDEO: 1.0 V [p-p] (75 Ω)

**Reference input:**

Analog composite, BNC x 2, loop-through, 75 Ω on/off

**SDI input (option):**

BNC x 2, active through, complies with SMPTE259M-C /ITU-R BT.656-4 standard

■ **Video Output Connector**

**Analog component output:**

BNC x 3 (Y, PB, PR)

Y : 1.0 V [p-p], 75 Ω

For AJ-SPD850P

P<sub>B</sub>/P<sub>R</sub> : 0.486 V/0.7 V [p-p] selectable

75 Ω (75 % color bar, setup level 7.5 %)

For AJ-SPD850E

P<sub>B</sub>/P<sub>R</sub>: 0.7 V [p-p]

75 Ω (100 % color bar)

**Analog composite output:**

BNC x 3, video 1, video 2, video 3 (superimpose on/off)

**SDI output (option):**

BNC x 3, complies with SMPTE259M-C

/ITU-R BT.656-4 standard

SDI 1, SDI 2, SDI 3 (superimpose on/off)

■ **Video Signal Adjustment**

**Video output gain:**

±3 dB

**Video output chroma gain:**

±3 dB

**Video output HUE (chroma phase):**

±30 °

**Video output setup level (black level):**

±14 IRE (±100 mV)

**Video output sync phase:**

±15 μsec

**Video output SC phase:**

±180 °

# Specifications (continued)

---

## AUDIO

### ■ Digital Audio

#### Sampling frequencies:

48 kHz (synchronous with video)

#### Quantizing:

16 bits

#### Frequency response:

20 Hz to 20 kHz  $\pm 1.0$  dB (at the reference level)

#### Dynamic range:

Better than 90 dB

(1 kHz, emphasis OFF, "A" weighted)

#### Distortion:

Less than 0.05%

(1 kHz, emphasis OFF, reference level)

#### Crosstalk:

Less than  $-80$  dB (1 kHz, between 2 channels)

#### Headroom:

For AJ-SPD850P: 20 dB

For AJ-SPD850E: 18 dB

#### De-emphasis:

T1 = 50  $\mu$ sec, T2 = 15  $\mu$ sec (auto on/off)

### ■ Audio Input Connector

#### Analog input (CH1, CH2, CH3, CH4):

XLR x 4, 600  $\Omega$ /high impedance selectable (factory setting: HIGH), +4/0/ $-20$  dBu selectable

#### Digital input (CH1/CH2, CH3/CH4):

BNC x 2, AES/EBU format

#### SDI input (option):

BNC x 2, active through,  
complies with SMPTE259M-C/272M-A  
/ITU-R BT.656-4 standard

### ■ Audio Output Connector

#### Analog output (CH1, CH2, CH3, CH4):

XLR x 4, low impedance, +4/0/ $-20$  dBu selectable

#### Digital output (CH1/CH2, CH3/CH4):

BNC x 2, AES/EBU format, 75  $\Omega$ , 1.0  $\pm$  0.2 V [p-p]

#### SDI output (option):

BNC x 3, 75  $\Omega$ ,  
complies with SMPTE259M-C/272M-A  
/ITU-R BT.656-4 standard

#### Monitor output:

XLR x 2, low impedance, +4/0/ $-20$  dBu selectable

#### Headphones:

Stereo mini jack, 8  $\Omega$ , variable level

## Other Input/Output Connectors

#### Time code input:

XLR x 1, 0.5 V to 8 V [p-p], 10 k $\Omega$

#### Time code output:

XLR x 1, low impedance, 2.0 V  $\pm$  0.5 V [p-p]

#### RS-422A input/output:

D-sub 9-pin, RS-422A interface

#### RS-232C:

D-sub 25-pin, RS-232C interface

#### Encoder remote:

D-sub 15-pin

Weight and dimensions when shown are approximately.  
Specifications are subject to change without notice.

## Information on Disposal for Users of Waste Electrical & Electronic Equipment (private households)



This symbol on the products and/or accompanying documents means that used electrical and electronic products should not be mixed with general household waste.

For proper treatment, recovery and recycling, please take these products to designated collection points, where they will be accepted on a free of charge basis. Alternatively, in some countries you may be able to return your products to your local retailer upon the purchase of an equivalent new product.

Disposing of this product correctly will help to save valuable resources and prevent any potential negative effects on human health and the environment which could otherwise arise from inappropriate waste handling. Please contact your local authority for further details of your nearest designated collection point.

Penalties may be applicable for incorrect disposal of this waste, in accordance with national legislation.

### For business users in the European Union

If you wish to discard electrical and electronic equipment, please contact your dealer or supplier for further information.

### Information on Disposal in other Countries outside the European Union

This symbol is only valid in the European Union.

If you wish to discard this product, please contact your local authorities or dealer and ask for the correct method of disposal.

# Panasonic®

**PANASONIC BROADCAST & TELEVISION SYSTEMS COMPANY**  
UNIT COMPANY OF PANASONIC CORPORATION OF NORTH AMERICA

#### Executive Office:

One Panasonic Way 4E-7, Secaucus, NJ 07094 (201) 348-7000

#### EASTERN ZONE:

One Panasonic Way 4E-7, Secaucus, NJ 07094 (201) 348-7621

##### Southeast Region:

1225 Northbrook Parkway, Ste 1-160, Suwanee, GA 30024 (770) 338-6835

##### Central Region:

1707 N Randall Road E1-C-1, Elgin, IL 60123 (847) 468-5200

#### WESTERN ZONE:

3330 Cahuenga Blvd W., Los Angeles, CA 90068 (323) 436-3500

#### Government Marketing Department:

52 West Gude Drive, Rockville, MD 20850 (301) 738-3840

#### Broadcast PARTS INFORMATION & ORDERING:

9:00 a.m. – 5:00 p.m. (EST) (800) 334-4881/24 Hr. Fax (800) 334-4880

Emergency after hour parts orders (800) 334-4881

#### TECHNICAL SUPPORT:

Emergency 24 Hour Service (800) 222-0741

#### Panasonic Canada Inc.

5770 Ambler Drive, Mississauga, Ontario L4W 2T3 (905) 624-5010

#### Panasonic de Mexico S.A. de C.V.

Av angel Urraza Num. 1209 Col. de Valle 03100 Mexico, D.F. (52) 1 951 2127

#### Panasonic Puerto Rico Inc.

San Gabriel Industrial Park, 65th Infantry Ave., Km. 9.5, Carolina, Puerto Rico 00630 (787) 750-4300

---

## Panasonic Broadcast Europe

## Panasonic Marketing Europe GmbH

Hagenauer Str. 43, 65203 Wiesbaden-Biebrich Deutschland Tel: 49-611-235-481