

SPROG DCC

SBOOST DCC Booster User Guide



Introduction

SBOOST is a DCC booster designed primarily intended for use with the SPROG II, but also useable with other DCC systems, to boost the track output current for driving a larger layout.

Requirements

- Regulated DC Power Supply 12 – 20V, 3A

Features

- Opto-isolated DCC input for electrical isolation between the layout and the command station
- DCC activity LED shows reception of valid DCC input
- Power LED flashes when programming track power is live

Specification/Operating Conditions

Parameter	Minimum	Typical	Maximum	Units
DC Input supply voltage	12V		20V	V
Vin supply current			2.6 Note 1	A
Output Load – Operating Layout			2.5	A
Auto reverse detection delay		1.2		ms
Overload detection delay		3.2		ms
Overload cutout delay		410		ms

1. The current capacity of the power supply must be greater than the 2.5A current limit of the SBOOST. A 3A power supply is recommended.
2. The DCC track voltage will be slightly less than the power supply voltage.

DCC Parameters	Minimum	Typical	Maximum	Units
DCC signal input voltage	7		18	V
DCC signal input current		10 Note 3		mA
DCC signal input current			16.5 Note 4	mA
DCC Input – Track Output Delay		1.6		μ s

3. Vin 12V

4. Vin 18V

LEDs

Track LED	Off	Track power off
	Flashing Moderately Quick	Track power on
	Flashing quickly	Short circuit
DCC LED	Flashing slowly	No DCC signal
	Flashing Quickly	Valid DCC Signal

Installation

The following steps are required to install SBOOST before you can use it for the first time:

- Connect to the Power Supply
- Connect to the Layout
- Connect to the Command Station

Connect to the Power Supply

Power supplies sold by SPROG DCC are supplied with a circular DC jack plug. This should be removed to allow connection to the pluggable terminal block:

- Cut off the DC plug
- Separate the two conductors for about 3cm

- Strip 6-8mm of insulation from each conductor and twist the copper cores of each conductor together
- Insert the conductor marked with a white stripe in the +V terminal and tighten the screw
- Insert the other conductor in the 0V terminal and tighten the screw

SBOOST is protected against reverse polarity connection of the power supply, but will not work unless the polarity is correct.

Connect to the Layout

Connect the SBOOST to the track using the track terminals “Tr A” and “Tr B” of the pluggable terminal block.

Connect to the Command Station

Connection to a SPROG II (version 2 and earlier)

The pluggable terminal block is arranged to allow a straight forward connection to a SPROG II for both the DCC signal and to supply power to the SPROG II (See below), see the picture below.

Connect the SBOOST DCC inputs “In A” and “In B” to the SPROG II track outputs.

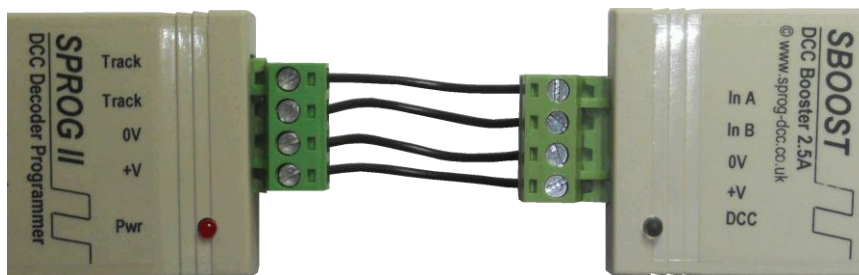

Powering a SPROG II (all versions)

There are two considerations to be taken into account when powering an SBOOST and a SPROG II from the same power supply.

The electrical isolation between the layout and command station (i.e. SPROG II) will no longer be effective.

The SPROG II has a lower maximum supply voltage of 15V, compared to the SBOOST maximum of 20V. When using an SBOOST with a supply voltage greater than 15V special care must be taken. For SBOOST supply voltages above 17V, a separate power source, of the correct voltage, should be used

for the SPROG II. For SBOOST supply voltages in the range 15 – 17V you can use a separate power supply or insert a string of 3 1N4001 (or similar) diodes in series with the +V connection to drop the voltage slightly.

Connect the SBOOST +V output to the SPROG II +V input.

Connect the SBOOST 0V output to the SPROG II 0 input.

Connection to a SPROG 3

Follow the connection instructions for SPROG II. The SPROG 3 is rated for the same maximum voltage as the SBOOST and can always use the same power supply.

If electrical isolation is required between the layout and SPROG 3 then a separate, isolated, power supply must be used.

Connection to Other Command Stations

TBD

Multiple Power Districts Using SBOOST

If more than one SBOOST is to be connected between the command station (e.g. one of the SPROG family) and the layout, to give multiple power districts, then care must be taken with both the DCC input connections and the track connections to ensure the same polarity at each SBOOST.

Connect all of the SBOOST “In A” terminals together and connect to one output of the command station.

Connect all of the SBOOST “In B” terminals together and connect to the other output of the command station.

Connect the “Tr A” and “Tr B” outputs to the layout in a consistent manner in each power district. E.g. connect “Tr A” to the left rail in each power district and connect “Tr B” to the right rail in each power district.

BOTH rails MUST be gapped between power districts. The SBOOST track outputs must only be connected to their own power district, i.e., there must be NO common wiring between power districts.

If a single power supply is used to power more than one SBOOST it must be rated to supply the maximum current to all SBOOST simultaneously. E.g. for two SBOOST the power supply must be rated at greater than 5 Amps.

If separate power supplies are used to power multiple SBOOST then they should all be of the same type and voltage rating. The 0V connections of all

the SBOOST must be connected together. This is sometimes referred to as a booster “home ground” connection.

Example 1

SPROG 3 (or SPROG II) and SBOOST with common power supply.

Using a SPROG 3 and SBOOST in this way is not recommended.

A short circuit in the SPROG 3 power zone will affect the DCC signal to the SBOOST.

The power supply must be able to supply the full rated current (i.e., at least 5 Amp for SPROG 3 plus SBOOST).

Power districts must be separated by isolation gaps in both rails.

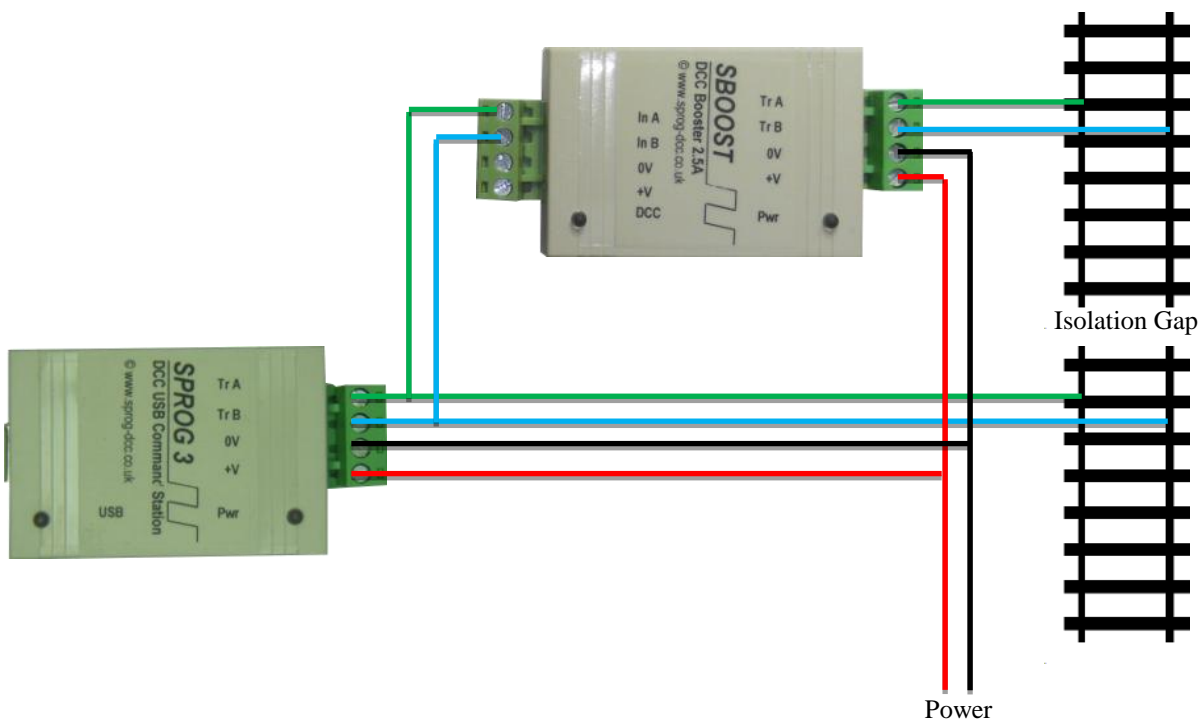

Example 2

SPROG 3 and SBOOST with separate power supplies.

Using a SPROG 3 and SBOOST in this way is not recommended.

A short circuit in the SPROG 3 power zone will affect the DCC signal to the SBOOST.

Each power supply should be the same voltage.

Each power supply must be able to supply the full rated current, at least 2.5 Amp.

A common ground connection is required between the power supplies.

Power districts must be separated by isolation gaps in both rails.

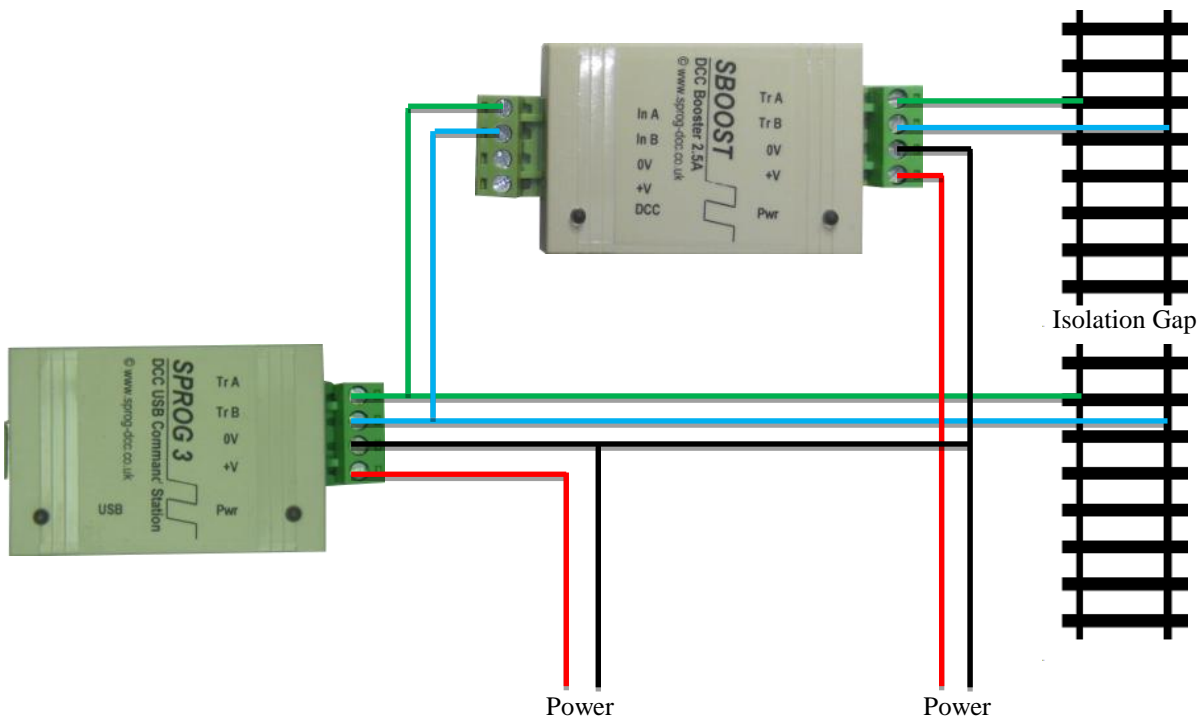

Example 3

SPROG 3 (or SPROG II) driving multiple SBOOST with common power supply.

The power supply must be able to supply the full rated current (e.g., at least 5 Amp for 2 x SBOOST).

Power districts must be separated by isolation gaps in both rails.

The SPROG can be powered from one of the SBOOST

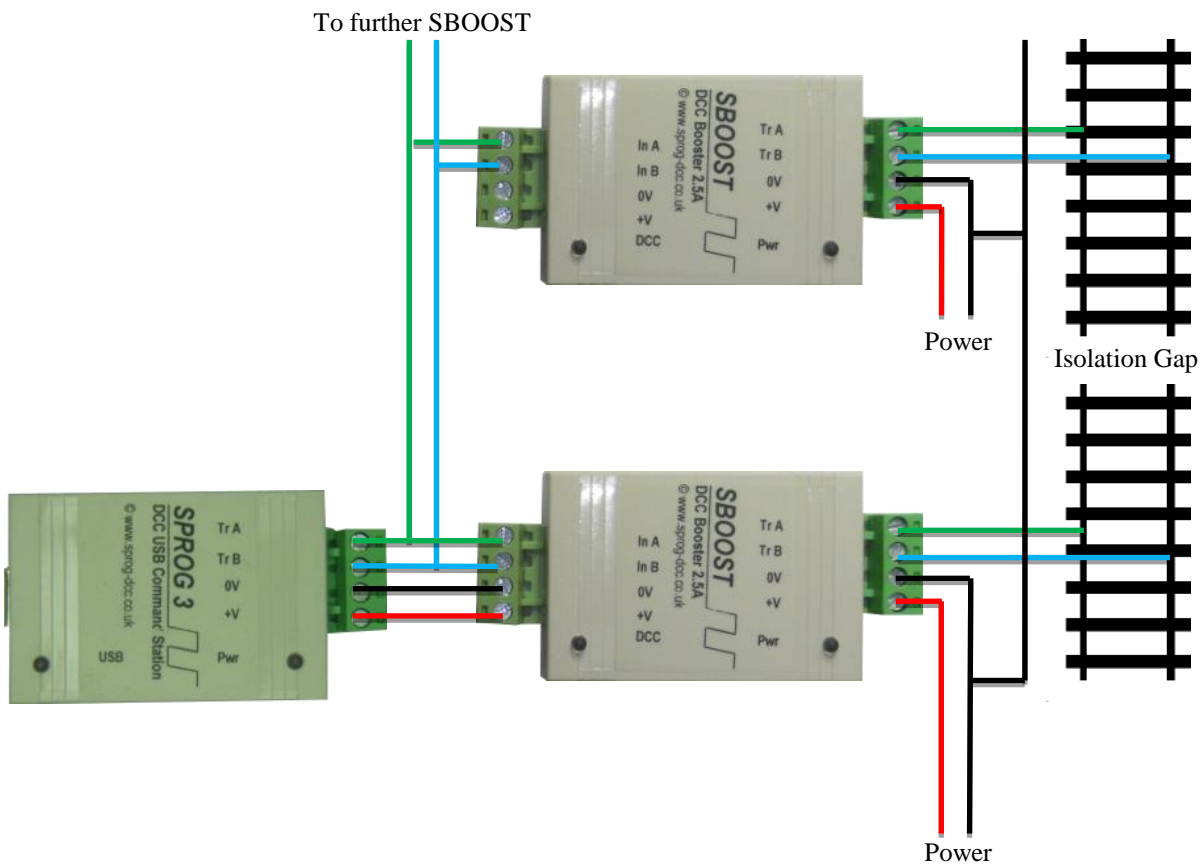

Example 4

SPROG 3 (or SPROG II) driving multiple SBOOST with separate power supplies.

Each power supply should be the same voltage.

Each power supply must be able to supply the full rated current, i.e. at least 2.5 Amp.

A common ground connection is required between the power supplies.

Power districts must be separated by isolation gaps in both rails.

The SPROG can be powered from one of the SBOOST.

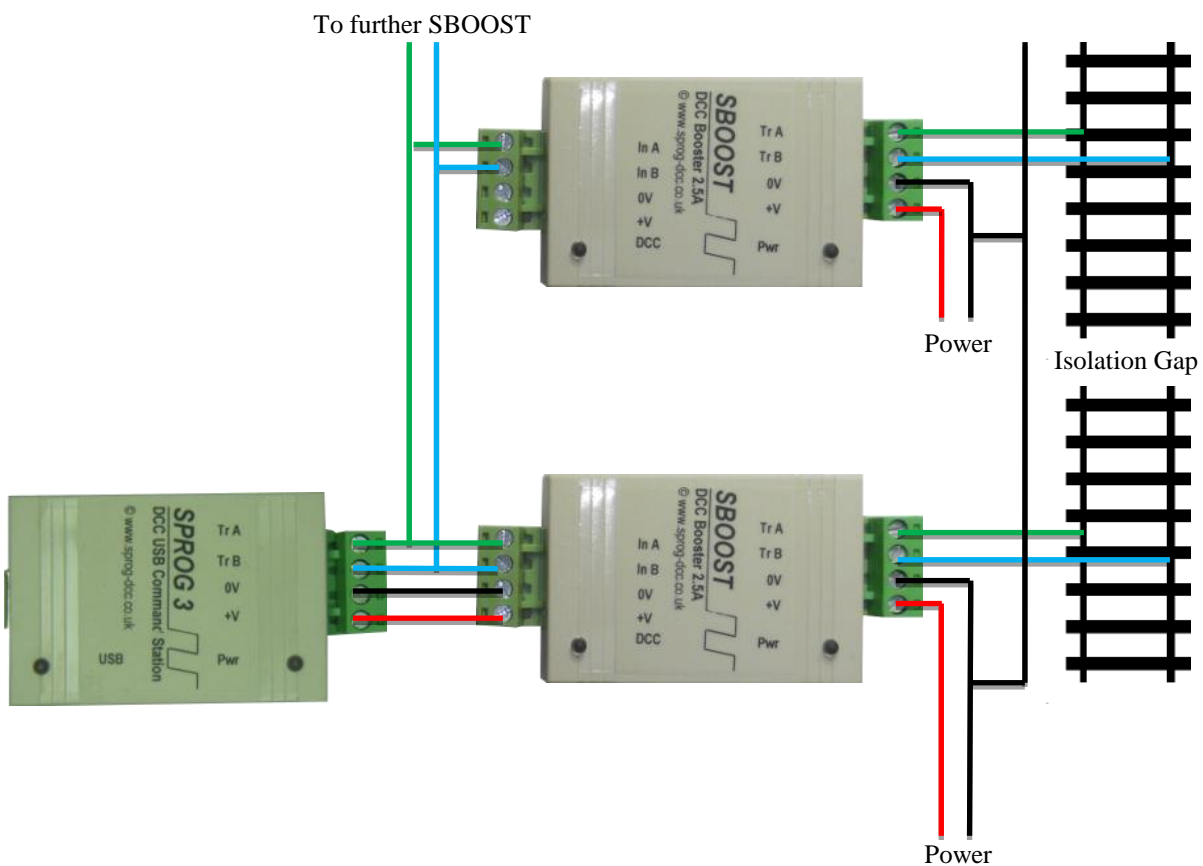

Auto-reverse Operation

The SBOOST can be configured for auto reverse operation, e.g., to supply power to a reverse loop or wye formation as a separate power district.

To enable or disable auto-reverse operation you must open the casing of the SBOOST and fit or remove a jumper link.

To open the casing, prize the two halves apart by inserting a small flat bladed screwdriver in the slots and twisting gently, as shown below.

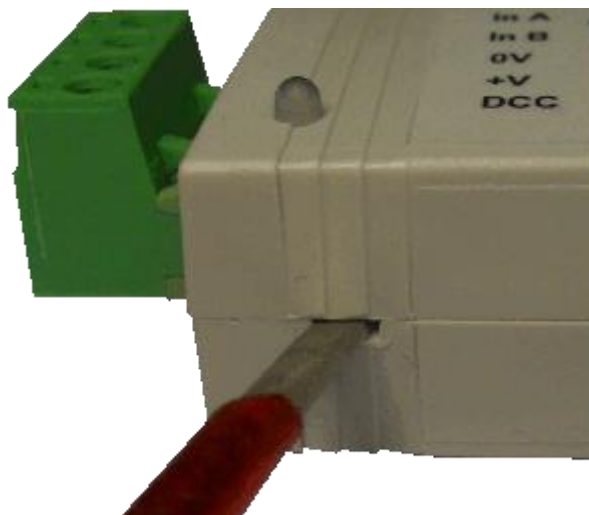

Identify the location for the jumper link near the DCC input connector, see below.

When no jumper link is fitted, auto-reverse operation is disabled:



When a jumper link is fitted, auto-reverse operation is enabled:

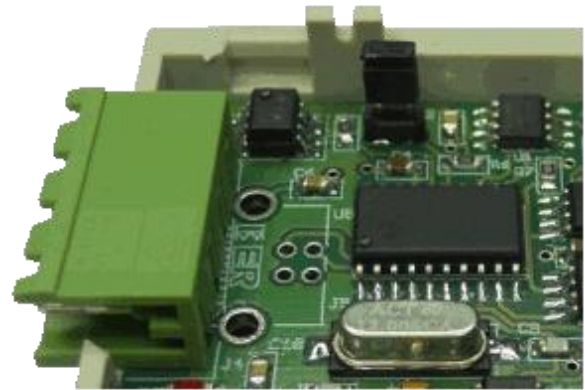

Auto-reverse operation must not be enabled in adjacent power districts. This may cause “thrashing” as both SBOOST try to auto-reverse simultaneously.

For UK customers, spare jumper links may be obtained from SPROG DCC on receipt of a stamped self-addressed envelope. They are also available from electronic component suppliers.

Gently refit the casing by lining up and gently squeezing the two halves together.

Troubleshooting

Before reporting any problems please check the SPROG-DCC webpages for any bug reports or updates.

Useful Links

SPROG homepage <http://www.sprog-dcc.co.uk> for the latest information, updates, downloads, etc., for SBOOST.

SPROG DCC Yahoo group <http://groups.yahoo.com/group/sprog-dcc> for latest news and discussion.