

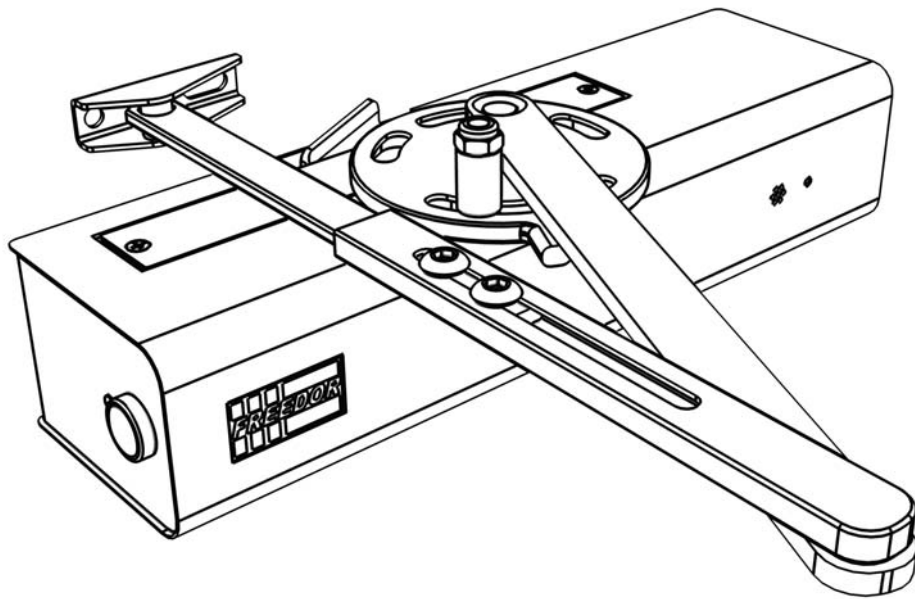

**Fitting and
Operating Guide**
plus
Maintenance Test Record



Keep this guide in a safe place.

| Contents | Page |
|--|-------------|
| Introduction and Glossary | 2 |
| Contents of the Box | 3 |
| Prior to Installation | 4 |
| Important Information | 5 |
| Door Type and Installation Position | 6 |
| Preparing Freedor | 7 |
| Installation - Radial Arm Set-up (Pull Side) | 8 |
| Installation - Closer Arm Installation (Pull Side) | 9 |
| Installation - Radial Arm Set-up (Push Side) | 10 |
| Installation - Closer Arm Installation (Push Side) | 11 |
| Installation - Mounting Freedor | 12 |
| Installation - Additional Functionality | 13 |
| Installation - Cover Assembly | 14 |
| Installation - Battery Installation | 15 |
| Operation and Self-Test | 16 |
| Testing Freedor using the Fire Alarm | 17 |
| Sensitivity Adjustment | 18 |
| Battery Pack Replacement | 19 |
| Troubleshooting and FAQs | 20 |
| Beeps and Flashes | 22 |
| Maintenance Schedule | 24 |
| Maintenance Record | 25 |
| Commissioning Certificate | 26 |
| Manufacturer's Warranty | 27 |

Manufacturer's Classification:-
 As required By EN 1154:1997 and EN 1155:1997
 ID of Certification Body: 1121
 Registered Address:- Fireco Ltd., 30 New Road, BRIGHTON BN1 1BN, UK
 Power size: 3
 Manufactured in the UK
 Tested and found to comply with all the relevant clauses of
 those standards harmonised under the CPD
 (EU Construction Products Directive)



| | | | | | | |
|-----------------------|---|---|---|----|---|---|
| EN1154:1997 + A1:2002 | 4 | 8 | 3 | 1* | 1 | 3 |
| EN1155:1997 + A1:2002 | 3 | 8 | 3 | 1* | 1 | 0 |

Introduction and Glossary

Freedor is a battery operated electrically powered free-swing door closer for fire doors with Category B signal activation to BS7273-4. It is designed to allow users to hold open a fire door safely and legally, and it will automatically release upon “hearing” the fire alarm.

It is recommended that a fire door is not held open at an angle of less than 65 degrees.

Glossary of Terms used in this guide.

Set Angle - The position of the radial arm bolt on the radial arm will determine the angle at which Freedor will enter free-swing mode.

Door closer mode - The default mode for Freedor. No matter what angle Freedor is opened to, it will close the door.

Free-swing mode - If Freedor is in the free-swing mode, it will act as if there is no door closer fitted, after it is opened to the set angle.

Fire Alarm mode - Upon detecting the noise of a fire alarm, Freedor will sound ten “Hi-Lo” tones whilst flashing the LED red. Freedor will cause the door to close if it is being held open and then sound ten “Lo-Hi” tones to indicate closure due to the fire alarm.

Fail-to-Safe mode - If Freedor fails a self-test, it will fail-to-safe and close the door. The unit will then start to beep and flash its LED in a sequence dependant on the error. During this mode, the reset button will not be useable and Freedor will not hold the door open until the error has been cleared.

Reset Button - Depressing the reset button will change the mode that Freedor is currently in. Holding the reset button for 5 seconds will cause Freedor to perform a soft-reset. This button will become disabled during fail-to-safe mode and will be temporarily disabled for 5 seconds after use.

LED - Light Emitting Diode. Adjacent to the reset button is a bi-colour LED which illuminates red or green. The LED flashes to signal the Freedor’s status.

Battery tamper microswitch - Connecting the battery pack and securing the two battery lift screws will depress a tamper switch. If the battery lift is removed during operation, the tamper switch will change state and Freedor will enter a fail-to-safe mode and close the door.

PCB (Printed Circuit Board) - The PCB houses all the electronics used to make Freedor function. It sits above the magnet assembly and has the DIP switches and variable resistor which sets the unit’s functionality and audio sensitivity respectively.

Contents of the Box

Please check that you have all the contents listed below.

The Freedor box contains:

- 1 x Freedor unit
- 1 x User Guide
- 1 x Fitting Template
- 1 x Closer Arm Pack
- 1 x Parallel Arm Bracket
- 1 x Battery Pack
- 1 x Freedor Adhesive Logo
- 1 x Radial Arm
- 1 x Radial Arm Bolt & Radial Arm Pivot Bag
contains: 1 x Radial Arm Assembly,
1 x Radial Arm Pivot Assembly
- 1 x Freedor Body & Arm Fixtures
contains: 4 x No. 8 Screw, 2 x No. 10 PH
Screw, 4 x No. 10 CSK Screw,
M5 Short PH Screw,
1 x Black Plastic Screwdriver

Tools and Equipment Required:

- Pozidriv No. 2 screwdriver
- Flat-blade screwdriver
(no wider than 6mm)
- Electric drill
- Drill bits: 3mm diameter
- 11mm socket and ratchet
- 13mm spanner
- Stud and cable detector
- Marker pen
- Safety goggles

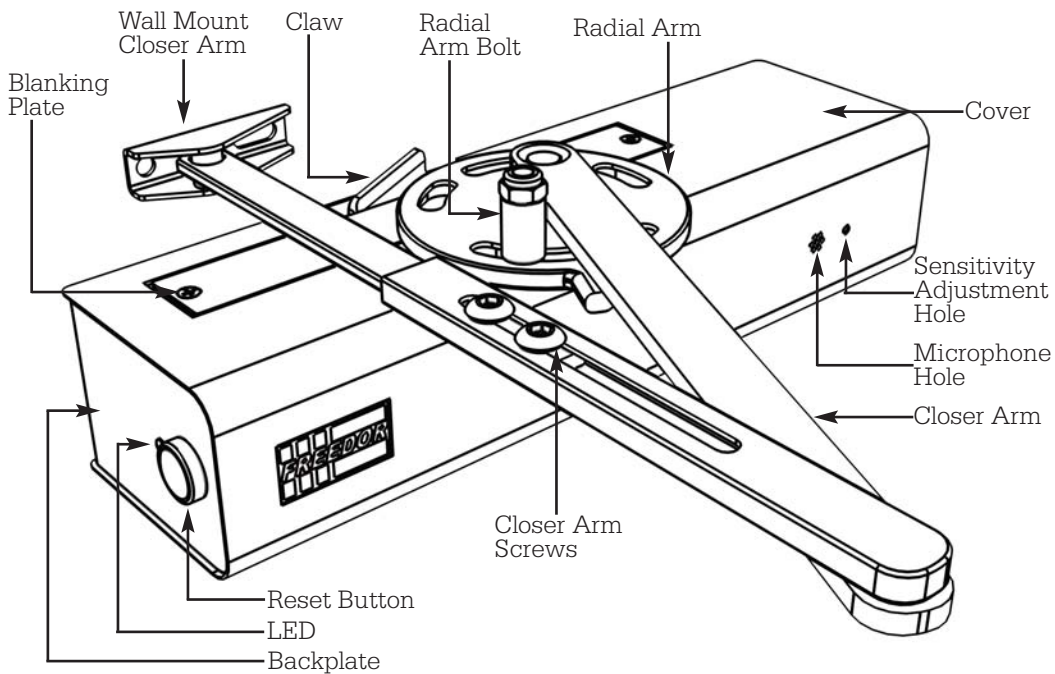

Prior to Installation

Please ensure the following:

1. That a suitable Automatic Fire Detection alarm system is installed;
2. The Fire Alarm system is working correctly, i.e. the sounders work when activated;
3. The fire door closes tightly against the frame whilst checking the fire door is fully compliant as intended;
4. Freedor is of a suitable power size for the door it is to be installed on;
5. The door, the door frame and surrounding fixing points are checked for potential interferences or danger, such as electrical wiring;
6. The fire door is suitable for Freedor installation. In a power size 4 installation, Freedor is suitable for fire doors up to 1100mm wide and 80kg;
7. An internal stop should be installed to prevent Freedor being opened past its maximum opening angle; i.e. 105 degrees when installed on the pull side and 135 degrees when installed on the push side. The stop must be of a standard design and correctly fixed;
8. Freedor should be included in the Fire Risk Assessment (as required by the Fire Precautions [Workplace] Regulations 1997, also required by the Regulatory Reform (Fire Safety) Order 2006);
9. When Freedor is holding a fire door open, the Freedor “listens” continually for the sound of a fire alarm. When the alarm sounds, Freedor will verify the alarm over a 20 second period and then cause the fire door to close.

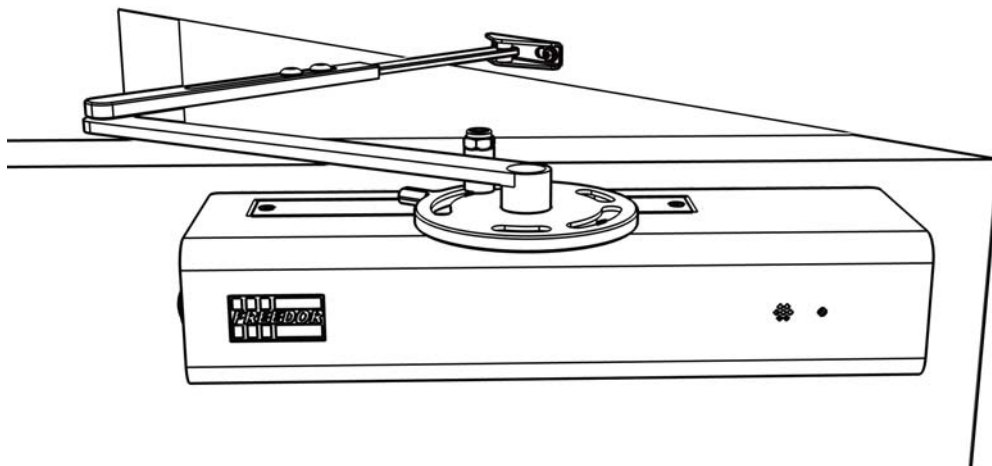

Important Information

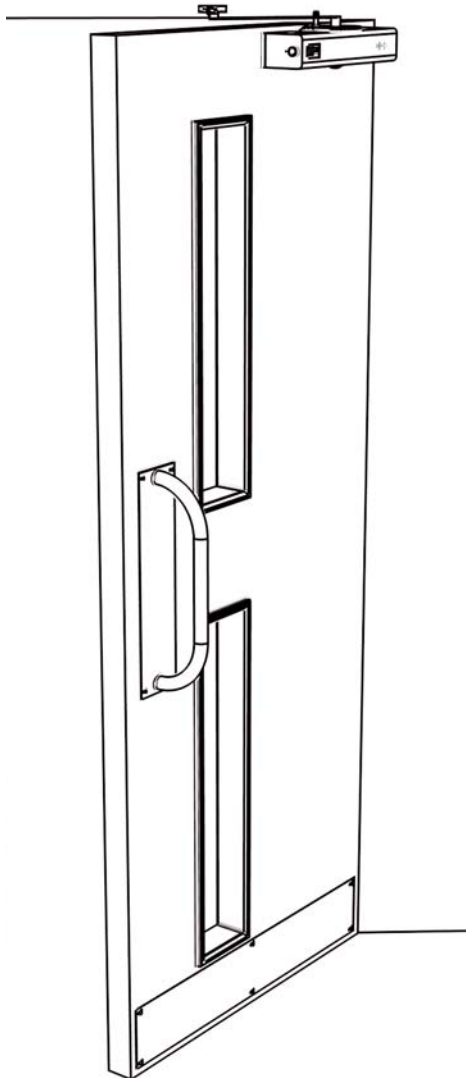

Freedor must only be used for the purpose for which it is designed. It is not suitable for external use. Read this guide and follow the instructions carefully. Keep this guide in a safe place e.g. in the Fire Risk Assessment file for future reference.

Freedor, when installed correctly, complies with BS 7273-4 Category B.

Supplementary information about the sound generated by a fire alarm: The British Standard for fire alarm installation, BS 5839-1: 2002, (Clause 16.2), states:

The sound pressure level of alarm signals should be generally, throughout all accessible areas of the building not less than 65dB (A) ... where the sound pressure level of background noise is greater than 60dB (A), the sound pressure level of the fire alarm signal should be 5dB above the sound pressure level of the background noise.

Power Supply

Rated Voltage: 9.82V

Power Consumption (at rated voltage): 0.05W

Protection: Resettable solid state fuse

Freedor constantly checks the voltage of the connected battery pack and will fail-to-safe on detecting the voltage reaching a low level. Freedor will not start-up if a low voltage condition is detected.

Only connect new battery packs supplied by Fireco Ltd. or by approved suppliers of Freedor. Failure to do so and the use of unauthorised battery packs could result in damage to the product and cause it to become unsafe.

Door Type and Installation Position

Freedor can be installed in one of four positions; clockwise or anti-clockwise opening doors, and on the pull side or push side of the door. Using the diagram below, determine where you wish Freedor to be installed.

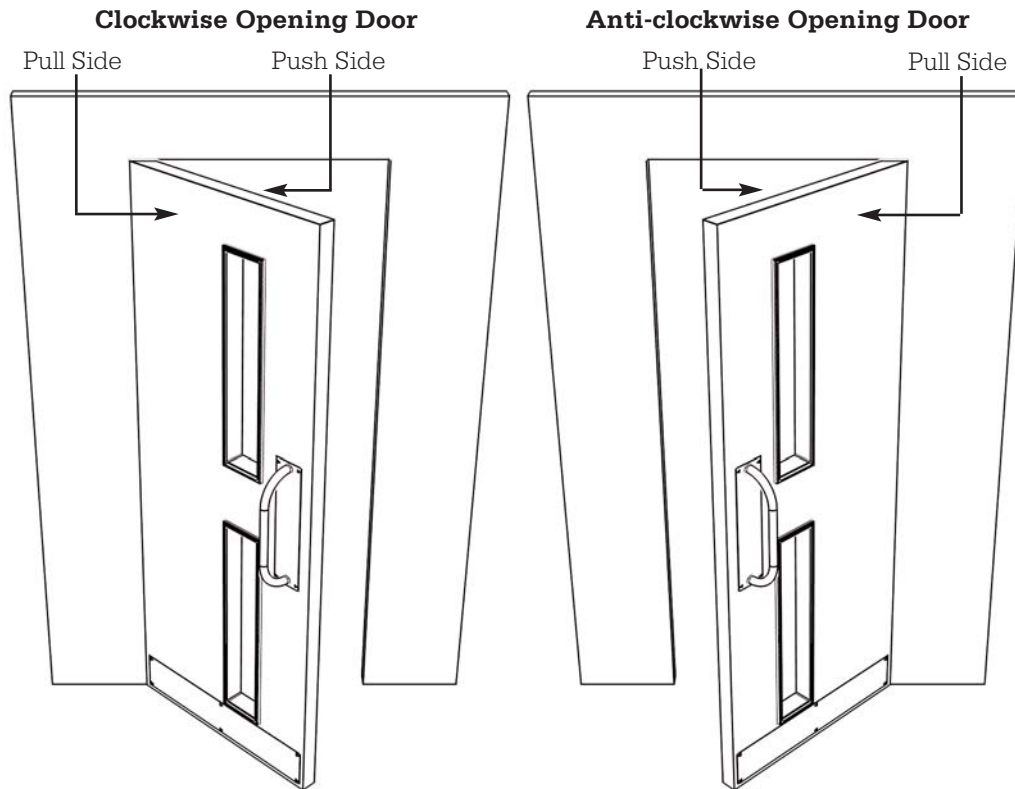

During the installation process, the method for installing Freedor will differ depending on which side of the door it is to be installed. If the title of the installation section of this guide mentions a specific side, make sure it is the correct side for the installation. This rule also applies to various steps which will present a "pull" and "push" side option. If the installation section does not mention a specific side, it is correct to follow for either installation type.

Preparing Freedor

Freedor requires minor dis-assembly to prepare it for installation upon the door. Follow the instructions detailed below to prepare Freedor for installation.

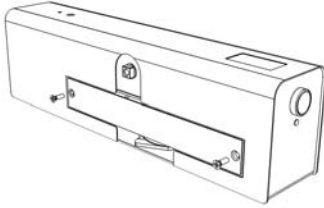

1. Remove the Freedor body from under the top tier of packaging.
2. Unscrew the 2 screws holding down the blanking plate and lift it away.
3. Unscrew the 2 screws holding the battery lift and slide it gently away from the cover.

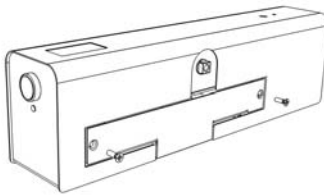

4. Gently push the battery lift legs toward each other so that they can clear the cover and remove the battery lift.
5. Once the 4 holding screws are removed from the cover (2 from the blanking plate, 2 from the battery lift), the cover can be removed.

The instructions for the Radial Arm Set-up and Closer Arm Installation are set out on separate pages for pull and push side installation. Ensure that the instructions for the required configuration are followed.

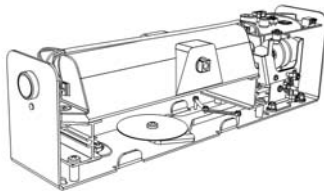
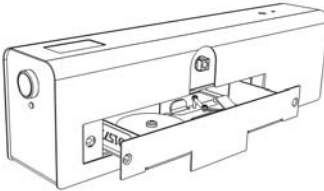

Installation - Radial Arm Set-up (Pull Side)

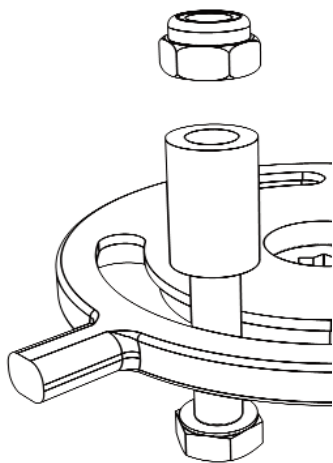

Pull side installation only - for push side instructions, see page 10.

1. Remove the radial arm and the radial arm bolt assembly from the packaging. The radial arm bolt assembly contains: 1 x M8 Bolt, 1 x Metal Sleeve and 1 x M8 Nyloc Nut.
2. Using the diagrams below, select the angle at which the door will enter free-swing mode and insert the bolt through the slot in the radial arm at the correct position. The diagrams show the minimum, maximum and right-angle installation points for the radial arm bolt; the bolt can be installed at any position between the minimum and maximum points.
3. Assemble the radial arm bolt by sliding the sleeve and the nyloc nut onto the bolt. Tighten down the nut to fasten the bolt to the radial arm.

Clockwise Opening

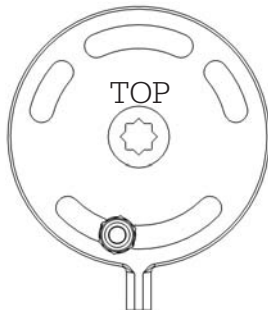

65 degree set angle
(min.)



90 degree set angle



105 degree set angle
(max.)

Anti-clockwise Opening



65 degree set angle
(min.)



90 degree set angle



105 degree set angle
(max.)

Installation - Closer Arm Installation (Pull Side)

Pull side installation only - for push side instructions, see page 10.

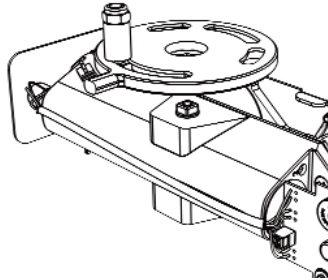

1. Place the radial arm and radial arm bolt assembly on the square pinion of the closer so that the radial arm nib sits at right angles to the backplate.

2. Take the largest metal washer from the door closer arm pivot pack and place it on the central recess of the radial arm.

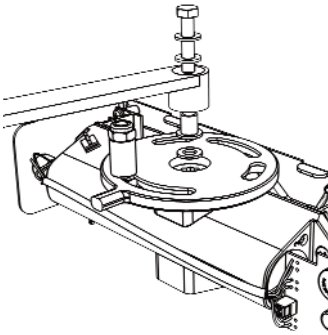

3. Push the nylon shoulder washer into the door closer arm from the flat bottom side. Place the door closer arm on top of the radial arm, ensuring the door closer arm sits between the Freedor PCB and the radial arm bolt.

4. Place the nylon washer and metal washer into the door closer arm (in that order). Tighten the door closer arm to the closer body using the door closer bolt. Tighten the bolt until the arm is secure ensuring it is not over tightened. Check that the arm can move with little resistance, loosen the bolt if necessary.

Note. The two diagrams below are examples of how the backplate assembly should look at this stage.

Installation instructions continue on page 12.

Clockwise Opening

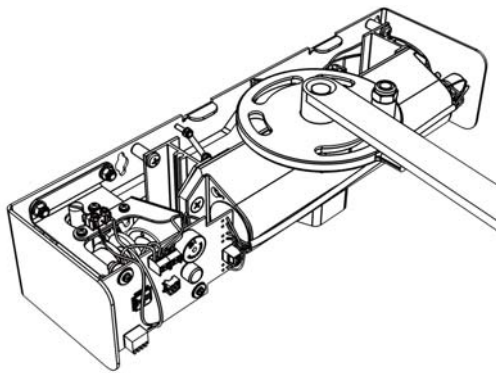

Anti-clockwise Opening

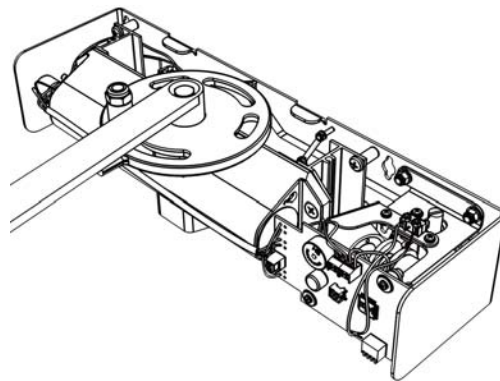

Installation - Radial Arm Set-up (Push Side)

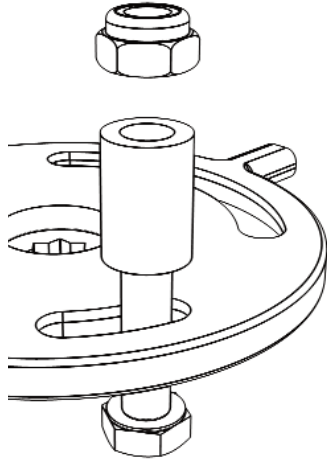

Push side installation only - for pull side instructions, see page 8.

1. Remove the radial arm and the radial arm bolt assembly from the packaging. The radial arm bolt assembly contains: 1 x M8 Bolt, 1 x Metal Sleeve and 1 x M8 Nyloc Nut.
2. Using the diagrams below, select the angle at which the door will enter free-swing mode and insert the bolt through the slot in the radial arm at the correct position. The diagrams show the minimum, maximum and right-angle installation points for the radial arm bolt; the bolt can be installed at any position between the minimum and maximum points.
3. Assemble the radial arm bolt by sliding the sleeve and the nyloc nut onto the bolt. Tighten down the nut to fasten the bolt to the radial arm.

Clockwise Opening



85 degree set angle
(min.)



90 degree set angle



95 degree set angle
(max.)

Anti-clockwise Opening



85 degree set angle
(min.)



90 degree set angle



95 degree set angle
(max.)

Installation - Closer Arm Installation (Push Side)

Push side installation only - for pull side instructions, see page 8.

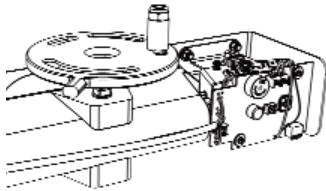

1. Place the radial arm with the newly fitted radial arm bolt on the square pinion of the closer so that the radial arm nib sits at a 45 degree angle to the backplate, facing toward where the hinge will sit.

2. Take the largest metal washer from the door closer arm pivot pack and place it on the central recess of the radial arm.

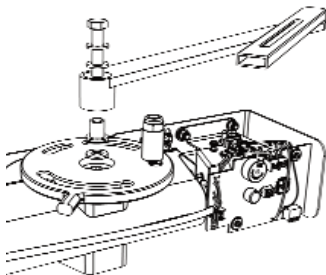

3. Push the nylon shoulder washer into the door closer arm from the flat bottom side. Place the door closer arm atop the radial arm, ensuring the door closer arm sits between the backplate and the radial arm bolt.

4. Place the nylon washer and metal washer into the door closer arm (in that order). Tighten the door closer arm to the closer body using the door closer bolt. Tighten the bolt until the arm is secure ensuring it is not over tightened. Check that the arm can move with little resistance, loosen the bolt if necessary.

Note. The two diagrams below are examples of how the backplate assembly should look at this stage.

Clockwise Opening

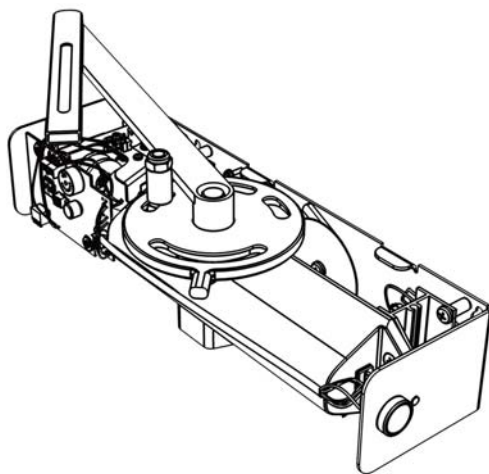

Anti-clockwise Opening

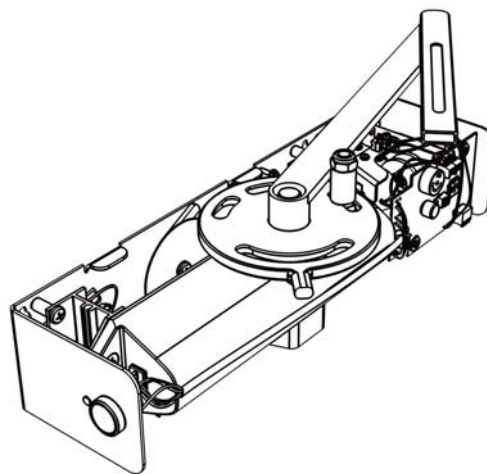

Installation - Mounting Freedor

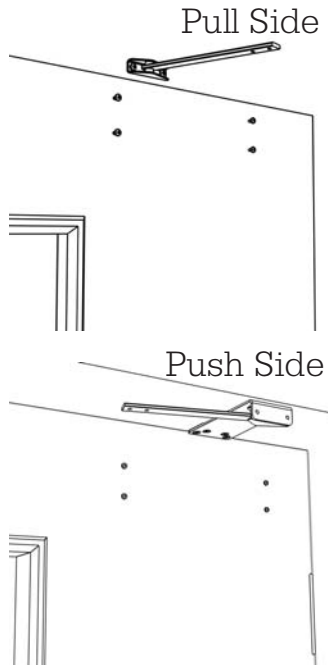

1. Place the fitting template against the door with the required orientation facing you (template A for pull side installation and template B for push side installation).
2. Fold the template along the upper fold line and hold it on the door, following the instructions for correct placement.
3. Mark through the template in the desired locations for the Freedor body and wall mount closer arm fixtures. Drill pilot holes using a 3mm drill bit fitted in an electric drill.
4. Screw a Freedor fitting screw into each of the 4 pilot holes made in the door. Leave a gap of approximately 5mm under the screw head.
5. Unscrew the two hexagonal head screws connecting the two closer arm parts together.

- 6.A. **Pull Side Installation.** Using the two closer arm fitting screws, affix the wall mount closer arm to the door frame following the template for correct orientation.

OR

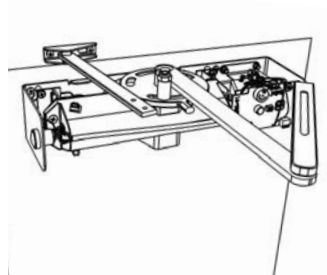

- 6.B. **Push Side Installation.** Take the wall mount closer arm and affix this to the parallel arm bracket using the short screws included in the same pack as the bracket fitting screws. Using the four parallel arm bracket screws, affix the parallel arm bracket to the underside of the door frame.

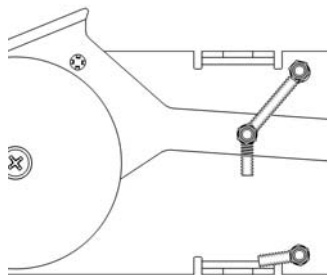

7. Hang the backplate assembly on the door using the 4 screws fitted in step 4. Secure Freedor to the door by tightening the 4 screws fully.
8. Locate the 2 claw springs connected between the claw and the backplate. Cut the lowest claw spring in two, allowing the upper most spring to pull the claw upwards.
9. Loop the battery input wiring over the closer so it is accessible from beneath the closer.

Installation - Additional Functionality (inc. Automatic Free-swing)

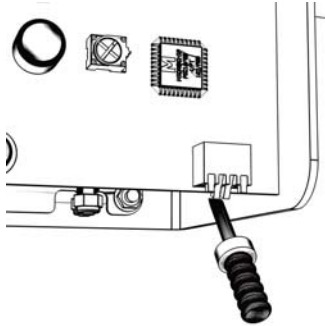

The factory default setting for DIP switches 1, 2 & 4 is OFF, DIP switch 3 is set to ON and should only be turned OFF if Automatic Free-swing is to be disabled, see below for details. Freedor will only change modes if prompted to do so by the user or a fire alarm or fault is detected.

Freedor can perform night-time releases, automatically enter free-swing mode or perform a weekly self-test by setting the appropriate DIP switch.

When adjusting the DIP switches, ensure the supplied black screwdriver is used to avoid damage being caused to the PCB by static discharge.

| DIP Switch | Release Time | Reset Time |
|------------|--------------|------------|
| 1 | 20:00 | 8:00 |
| 2 | 21:00 | 7:00 |
| 1 and 2 | 22:00 | 6:00 |

Night-time Release - DIP switches 1 & 2

This function will place Freedor into door closer mode and it will not enter free-swing mode until the reset time is reached. Whenever Freedor starts-up or performs a soft-reset, it will assume the time is 12:00 noon. The times stated in the table to the left are correct if Freedor starts-up at 12:00 noon.

Using the night-time release table on the left, choose the time span for Freedor to enter night-time release. With the black plastic screwdriver supplied, push the DIP switches toward the PCB for the time range selected

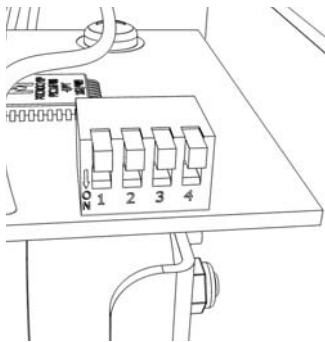

Automatic Free-swing - DIP switch 3

If Freedor closes the door due to either the detection of a fire alarm, a night time release or a self test, then by default Freedor will revert to Free-swing mode 30 seconds after the door closes. For night time release this will be when the reset time is reached. The door then only has to be re-opened beyond the set angle to hold it open. Turning DIP switch 3 to OFF disables Automatic Free swing mode and Freedor operates in door closer mode, requiring the reset button to be pressed after the door closes.

| DIP Switch | Self-Test Tones |
|------------|-------------------------|
| 3 ON | Automatic Free-swing ON |
| 4 ON | Weekly Self-test ON |

Weekly Self-Test - DIP switch 4

If Freedor is to perform a weekly self-test, set DIP switch 4 to ON. 6½ days after start-up, Freedor will perform a self-test; it will then perform a self-test every 7 days at the same time. If the door is being held open during a self-test, it will be released and require resetting by either the reset button, or will automatically reset if DIP switch 3 is ON.

Installation - Closer Speed Adjustment and Cover Assembly

Pull Side

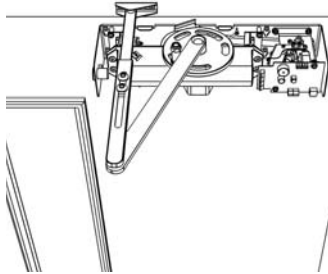

- 1.A. **Pull Side Installation.** Slide the door closer arm around the wall mount closer arm and pull the door closer arm so that the wall mount closer arm is at a right angle to the door. Secure the arm in this position using the two closer screws.

OR

- 1.B. **Push Side Installation.** Slide the door closer arm around the wall mount closer arm and pull the door closer arm so that the wall mount closer arm is parallel to the door. Secure the arm in this position using the two closer screws.

Push Side

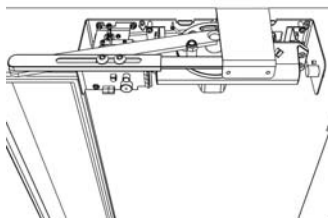

2. Freedor will now act as a door closer, allowing the adjustment of the closing and latching speeds of the closer. To increase the closing rate of either the closing or latching speed, loosen the appropriate regulator bolt; to slow the rate, tighten the regulator bolt. The regulator bolts are located on the closer. The closing speed is governed by the bolt labelled 1 and the latching speed is governed by the bolt labelled 2.

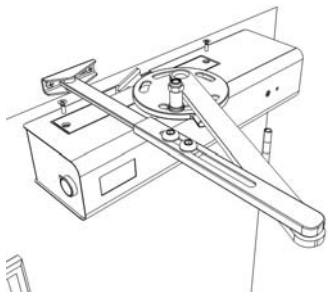

3. Slide the cover over the Freedor body ensuring that the cover is orientated such that the microphone and the sensitivity adjustment holes are over the PCB.

4. Place the Freedor logo sticker on the cover indent and place the plastic pinion cover over the closer pinion.

5. Place the blanking plate on top of the cover and secure it with the fixtures removed during the installation preparation.

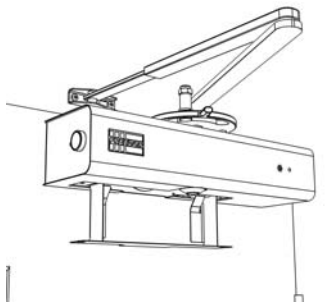

6. Similar to the removal of the battery lift during the Freedor installation preparation, gently push the battery lift legs towards each other so the battery lift is able to be slid into its original position. Do not secure the battery lift.

Installation - Battery Installation



1. With the Freedor fully assembled and closing the door correctly, take the battery pack from the Freedor packaging and record the installation date on the label fitted on the battery pack.

2. Connect the battery pack to the Freedor's battery pack connector that should be protruding from the bottom of the cover.



3. With the battery pack connected, place it on the battery lift. Push the battery lift up into the Freedor unit. Secure the battery lift with the screws removed during the installation preparation.

4. Once the battery lift is secured and the battery pack is connected, hold the reset button on the side of Freedor down until a continuous tone is heard. At this point release the button and the Freedor start sequence will commence.

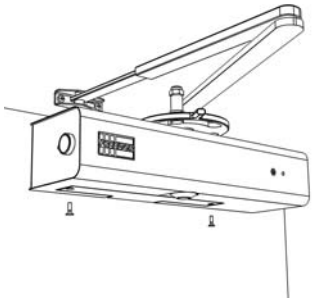

5. When Freedor is powered up it will assume the time is 12:00 noon.

Operation and Self-Test

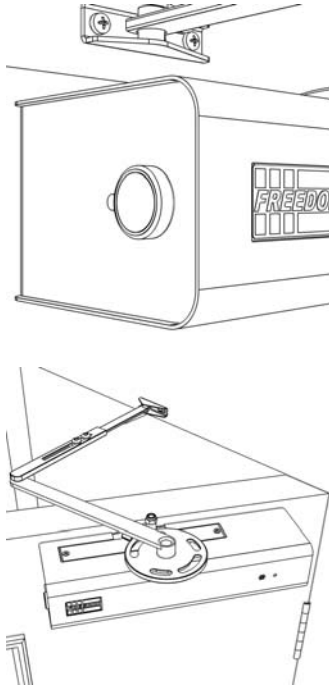

Freedor will operate in one of two modes after installation: either door closer mode, acting as a typical door closer; or free-swing mode.

Operation of Freedor differs, dependent on whether automatic free-swing is on (DIP switch 3 ON) or off (DIP switch 3 OFF).

Automatic Free-swing ON - DIP switch 3 ON

1. A few seconds after Freedor is powered up, Freedor will enter free-swing mode. Open the door past the set angle and Freedor will hold the door open.
2. If Freedor releases the door due to a fire alarm or self-test, it will reset to free-swing mode 30 seconds after the door is closed. If the fire alarm is still sounding, Freedor will continue to cycle from free-swing to door closer mode. It is important to note that Freedor will not hold the door open in free-swing mode until it is opened past the set angle.
3. In the event of night-time release, Freedor will close the door and re-enter free-swing mode automatically when the reset time is reached.

Automatic Free-swing OFF - DIP switch 3 OFF

1. After Freedor is powered up, press the reset button. Freedor will enter free-swing mode. Open the door past the set angle and Freedor will hold the door open.
2. If Freedor releases the door due to a fire alarm or self-test, it will require the reset button to be pressed to set the unit back into free-swing mode. It is important to note that Freedor will not hold the door open in free-swing mode until it is opened past the set angle.
3. In the event of night-time release, Freedor will close the door and give a warning tone (*LoLoHiHi*) if the reset button is pressed. Once the reset time is reached, the reset button will become active again, allowing the user to set Freedor into free-swing mode again.

Testing Freedor using the Fire Alarm

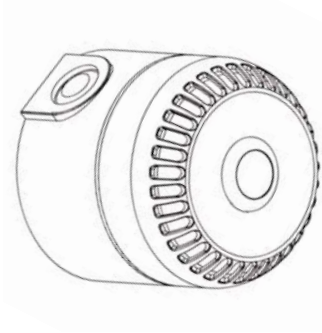

1. Set Freedor to free-swing mode, open the door past the set angle and allow Freedor to engage.
2. Sound the fire alarm until Freedor causes the door to close.
3. The LED on the side of Freedor should flash every 2 seconds to indicate it is “hearing” the sound of the fire alarm.
4. Freedor should release the fire door in under 20 seconds.
5. When Freedor is ready to release the door, it will sound a “high-low” warning tone, repeated a total of 10 times before releasing the door.
6. After Freedor has released the fire door (and the fire alarm has ceased) it can be reset after 10 seconds.

Note. If Freedor fails to react to the sound of the fire alarm, the sensitivity of the unit will need to be adjusted (see Sensitivity Adjustment).

Alterations to the premises i.e. new furniture, new carpets etc., might alter the audibility of the fire alarm. Following alterations, a fire alarm test must be carried out to ensure that Freedor responds.

Sensitivity Adjustment

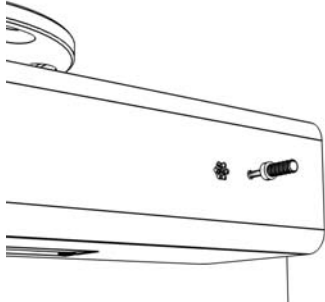

Acoustic Sensitivity
Minimum Release Level

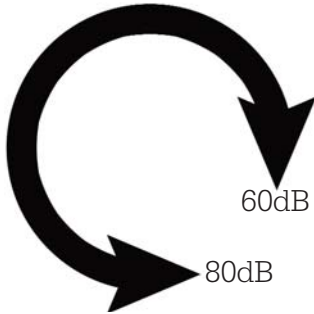

Each environment will vary and Freedor may need adjusting to suit individual conditions.

When making a necessary adjustment use the black plastic screwdriver supplied. Take care not to over adjust as this will render the unit inoperative.

Adjusting sensitivity if Freedor is not sensitive enough, i.e. does not respond to the fire alarm:

1. Carefully insert the black plastic screwdriver into the aperture on the front of the unit, next to the 7 holes for the microphone.
2. Turn clockwise through no more than 5 degrees (a small angular adjustment corresponds to a large alteration in sensitivity).
3. Test Freedor's response to the fire alarm.
4. If problems persist repeat steps 1-3.

Note. The adjustment screw is limited in both directions, once there is a resistance against turning - stop to avoid damaging the unit.

If Freedor is too sensitive (responds to no apparent sound) follow steps 1-4, but turn anti-clockwise in Step 2.

Note. When turned completely clockwise, Freedor needs to detect approximately 60dB to register a fire alarm. When turned completely anti-clockwise, Freedor needs to detect approximately 80dB to register a fire alarm.

Battery Pack Replacement

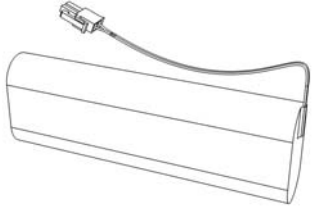

When the product determines that a battery low level has been reached (approximately 24 months), Freedor will fail-to-safe and will not allow the door to enter free-swing mode. If Freedor is sounding a “Hi-Lo Hi-Lo” tone once every 32 seconds, the battery pack will need replacing.

1. Unscrew the 2 screws securing the battery lift and let it gently drop down to expose the battery pack.
2. Remove the battery pack from the unit and disconnect the battery pack connector.
3. Record the installation date on the label fitted to the battery pack.
4. Connect the new battery pack and place it on the battery lift. Push the battery lift up into the Freedor unit. Re-secure the battery lift with the 2 screws.
5. Press the reset button on the side of Freedor until a continuous tone is heard. At this point release the button and the Freedor start sequence will commence.

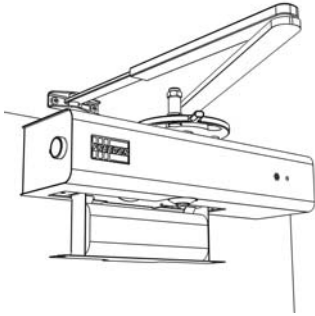

Note. Battery levels are checked once every 30 seconds in all modes.

Troubleshooting and FAQs

1. Why is Freedor not releasing when the Fire Alarm sounds?

- Check fire alarm sounds for at least 30 seconds.
- Check fire door is free to close unhindered.
- Check the fire alarm exceeds than 65 dB at the place where the Freedor is fitted.
- Adjust the sensitivity of the Freedor unit (see Sensitivity Adjustment).

2. Why does Freedor release if the fire alarm is not sounding?

- As a safety feature, Freedor has to release to any sound that it “hears” as being continuous and above 65 dB as this sound could potentially mask the sound of a fire alarm.
- Check night-time release settings.
- Adjust the sensitivity of the Freedor unit (see Sensitivity Adjustment).
- Check battery pack, is the unit beeping?

3. Why does Freedor not retain the door in an open position after the door has been opened past the set angle?

- Ensure Freedor is in free-swing mode. Press the reset button and a tone (*HiLo*) should sound.
- Is a tone (*LoLoHiHi*) produced every time the reset button is pressed? If so, Freedor is currently in night-time release mode and will not become active again until the reset time is reached.
- Is automatic free-swing mode turned on (DIP switch 3 ON)? If so, wait 30 seconds after a fire alarm/self-test and Freedor will reset to free-swing mode.
- Check that the battery lift is closed (secured up to the cover) and the battery pack is correctly installed.

Troubleshooting and FAQs continued

4. How can I reset the Freedor without re-installing the battery pack?

- Holding the push button down for 9 seconds in any mode will cause Freedor to perform a soft-reset. A soft-reset will have the same effect as re-installing the battery pack, unless Freedor has failed-to-safe. In the event of a failure or tones are heard from Freedor, refer to the Beeps and Flashes section for more information.

5. How do I change the night-time release, self-test settings or closing/latching speed once Freedor has been installed?

- The cover needs to be removed to access the closer and DIP switches. To remove the cover, follow the instructions found in the Preparing Freedor section. Freedor does not need to be removed from the door to change the closer speed or DIP switch settings.

6. Why is Freedor producing tones and flashing its LED?

- See Beeps and Flashes section for information relating to each sequence.

Beeps and Flashes

| Beep/Flash Sequence | What it means? | Remedy |
|--|--|---------------------|
| During Power up | | |
| Long Lo Tone | Indicates start of power up test. | No action required. |
| Lo - Lo - Lo | No DIP switches have been selected | No action required. |
| Hi - Lo - Lo | DIP switch 1 has been selected. | No action required. |
| Lo - Hi - Lo | DIP switch 2 has been selected | No action required. |
| Hi - Hi - Lo | DIP switches 1 and 2 have been selected | No action required. |
| Lo - Mid - Hi | Successful self-test | |
| During standard operation Key: * LED flash GREEN ○ LED flash RED | | |
| *---(32secs)---*---(32secs)---*---(32secs)---*---etc. | LED indicates that Freedor is working properly. | No action required. |
| Hi Lo and HiLo – HiLo – HiLo – HiLo * * * * | Freedor is preparing to change modes. | No action required. |
| HiLo – HiLo – HiLo – HiLo – HiLo – HiLo – HiLo – HiLo ○_____○_____○_____○_____○_____○_____○ HiLo – HiLo ○_____○ | Freedor is preparing to release the door due to a fire alarm | No action required. |
| LoHi – LoHi – LoHi – LoHi – LoHi – LoHi – LoHi – LoHi ○_____○_____○_____○_____○_____○_____○ – LoHi – LoHi ○_____○ | Freedor is resetting after releasing the door due to a fire alarm. | No action required. |

Beeps and Flashes continued

| Beep/Flash Sequence | What it means? | Remedy |
|---|---|--|
| Error Modes Key: * LED flash GREEN ○ LED flash RED | | |
| Lo – (2secs) – Lo – (2secs) – Lo – (2secs) – etc. ○-----○-----○-----etc. | Battery tamper switch not depressed. This will occur during power up but will stop when the battery lift is secured | <ol style="list-style-type: none"> 1. Unfasten the battery lift 2. Disconnect the battery pack 4. Wait 10 seconds 3. Connect the battery pack and secure the battery lift 4. Hold down the reset button to power up Freedor |
| LoLoHiHi | Reset Button is currently unusable | After each mode change there is a 5 second period where the reset button is unusable. Wait 5 seconds and try again. If Freedor has entered fail-safe mode due to night-time release, Freedor will be unusable until the night-time reset time is reached. |
| HiHiHiHiLoLoLoLo---(4secs)--- HiHiHiHiLoLoLoLo---(4secs)--- etc. | Indicates possible latching fault | <ol style="list-style-type: none"> 1. Open the door past the set angle and check if the door is being held open or not. 2. Press and hold the reset button until a soft reset occurs (10 seconds). 3. Ensure no foreign bodies, such as wires, debris, etc. are interfering with the device. 4. Replace the battery pack and repeat steps 1-3. 5. Contact Freedor Technical advice line if Freedor holds open the door. |
| HiLo----- (17 minutes)-- etc. | Low battery mode. | Battery levels are getting close to critical levels. Freedor will function normally until critical battery levels are reached. |
| HiLoHiLo----- (32 secs)--etc. | Critical battery mode. | Battery levels have reached a critical level and Freedor has failed-to-safe. Replace battery pack. |

Maintenance Schedule

Preventative maintenance and regular testing will ensure that Freedor functions correctly at all times. Keep the Maintenance Record up to date.

Weekly

Check Freedor is in the free-swing mode, open the door beyond the set angle and allow it to settle back. Sound the fire alarm, before the alarm has sounded for 30 seconds the door should be released and close. If the door is not released, refer to the troubleshooting section.

Monthly

Carry out the weekly test and in addition clean the unit checking that the 7 holes for the microphone aperture are open and clear of any dust, dirt etc. Freedor can be cleaned with a slightly damp cloth.

6 Monthly

Carry out the weekly and monthly schedule and in addition, check:

1. The Freedor unit for signs of wear;
2. The Freedor unit is firmly attached to the door, along with any arm attachments.

Yearly

Carry out the 6 monthly schedule and if possible, check the battery voltage.

Bi-Yearly

Replace battery pack.

Note and Warning

- The unit is designed to detect low battery power or possible faults, it will give a continual warning (sound a series of beeps) and will fail to safe (no longer operate as a hold open device).

Maintenance Record

The log sheet below is designed to cover a 12 month period and should be filled out after each alarm test. This log is a formal record of the test and maintenance schedule carried out by a competent (responsible) person(s) throughout the history of the installation of the Freedor unit.

Serial Number:

Location:

Serial Number is on the back of the Freedor unit.

Installation Date:

Installed by:

| Week | Result | Date | Sign | Week | Result | Date | Sign |
|-------------|---------------|-------------|-------------|-------------|---------------|-------------|-------------|
| 1 | | | | 27 | | | |
| 2 | | | | 28 | | | |
| 3 | | | | 29 | | | |
| 4 | | | | 30 | | | |
| 5 | | | | 31 | | | |
| 6 | | | | 32 | | | |
| 7 | | | | 33 | | | |
| 8 | | | | 34 | | | |
| 9 | | | | 35 | | | |
| 10 | | | | 36 | | | |
| 11 | | | | 37 | | | |
| 12 | | | | 38 | | | |
| 13 | | | | 39 | | | |
| 14 | | | | 40 | | | |
| 15 | | | | 41 | | | |
| 16 | | | | 42 | | | |
| 17 | | | | 43 | | | |
| 18 | | | | 44 | | | |
| 19 | | | | 45 | | | |
| 20 | | | | 46 | | | |
| 21 | | | | 47 | | | |
| 22 | | | | 48 | | | |
| 23 | | | | 49 | | | |
| 24 | | | | 50 | | | |
| 25 | | | | 51 | | | |
| 26 | | | | 52 | | | |

Commissioning Certificate

Certificate of commissioning for the electrically powered hold-open device(s) (please delete as appropriate) at: Address:.....

I/we being person(s) responsible (as indicated by my/our signatures below) for the commissioning of the above, particulars of which are set out below, CERTIFY that the equipment and release arrangements I/we have commissioned complies to the best of my/our knowledge and belief with the recommendations of BS 7273-4:2007 for the category of actuation described below, except for the variations, if any, stated in this certificate.

Name (in block letters):.....Position:.....

Signature:.....Date:.....

For and on behalf of:.....

Address:.....

.....Postcode:.....

The extent of liability of the signatory is limited to the equipment and arrangements described below.

Category B (acoustically activated Freedor)

Variations for the recommendations of BS 7273-4 (Clause 7).....

Brief description of release mechanisms, method(s) of actuation (see 7273-4:2007, Clause 8) and system design (see BS 7273-4:2007, Clause 10).....

All equipment operates correctly.

Installation work is, as far as can reasonably be ascertained, of acceptable standard.

I/we have carried out commissioning in accordance with recommendations of BS 7273-4:2007, 21.5

Suitability documentation has been completed before/after (delete as applicable) release mechanisms become operational.....

Maintenance: it is strongly recommended that, after completion, Freedor is maintained in accordance with BS 7273-4:2007, Clause 22.

User Responsibilities: the user should appoint a responsible person to supervise routine testing of release mechanisms in accordance with BS 7273-4:2007, 22.1 and to supervise all matters pertaining to the associated fire detection and fire alarm system in accordance with BS 5839-1:2002, section 7.

Manufacturer's Warranty

Fireco Limited ("we" and "us") warrants to the customer ("you" and "your") that the product will be free from defects in material and workmanship for a period of 24 months from the date of purchase. If the product is defective whilst under warranty we will, at our option, repair the product or replace it free of charge.

If the product appears to develop a defect while under warranty please first check that the product is being correctly used in accordance with this Fitting and Operating Guide and that the battery packs are functioning. If this does not resolve the problem, please contact us via e-mail or telephone the Freedor Technical Advice line below.

The warranty does not apply to any defect in the product arising from fair wear and tear, wilful damage, accident, negligence by you or any third party, abnormal working conditions, failure to follow the instructions in this guide, misuse or alteration or repair of the product without our prior approval. The warranty does not cover the battery pack which might need to be replaced within the period of the warranty. We will not be liable to you for any loss of profits, administrative inconvenience or indirect or consequential loss or damage arising out of any defect in the product.

Where the products are sold under a consumer transaction (as defined by the UK Consumer Transactions (Restrictions on Statements) Order 1976) your statutory rights are not affected by the terms of this warranty.



Version 1.5

For Technical Assistance contact the UK Technical Advice line on:

0845 241 7575 (Local Rate) or **+44 (0) 1273 320 688**

e-mail us at **help@firecoltd.com**

www.firecoltd.com

For all other queries please contact your supplier.