



küschall[®] *Compact*

CE



Table of contents

General	4
Introduction	4
Spare parts and adaptations	4
Fastening with hexagon socket bolts	4
Torque	5
Checks	5
Identifying and repairing faults	5
Frame	6
Rear frame	7
Front frame	7
Retaining lever	7
Seat	8
Seat height front (SHv)	8
Seat height rear (SHh)	9
Seat width (SB)	9
Seat depth (ST)	9
Backrest	11
Backrest height	11
Adjustable-angle backrest	12
Replacing push handles / push handles and backrest	14
Legrests	18
Footrests	19
One-piece footrest	19
Two-piece footrest	21
Two-piece footrest, adjustable-angle	21
Sideparts	22
Clothes guard/mudguard	22
Siderests	23
Front wheels	26
Castor fork	26
Special housing guides	27
Rear wheels	28
Adjusting the seat height rear	28
Tipping stability	28
Wheel camber	29
Adapter plate for drum brake	29
Distance sleeves for rear wheels	29
Brakes	30
Parking brakes	30
Drum brake	31
Options & accessories	32
Antitipper	32
Tipper aid	33
Cane holder	33
Transit wheels	34



General

Introduction

This Service Manual contains all the technical information necessary for the inspection, configuration or repair of a Küschall® wheelchair.

To maintain the necessary levels of safety and reliability, every wheelchair must be thoroughly examined once a year.

Some aspects of the assembly and configuration of the wheelchair require a high level of expertise. These assembly instructions therefore break the various tasks down into 3 categories:

Requirement	Symbol
Easy – technical understanding required	●○○
Medium – technical knowledge required	●●○
Difficult – technical knowledge and expertise in assembling wheelchairs required	●●●

The required tools and their sizes are listed before the instructions. The various torque values with which the nuts are to be tightened are also specified in the instructions. A torque spanner must be used, in order to comply with the specified torque values.

Tool	Symbol
Allen key	◆ 3, 4, 5
Torx wrench	✱ 10
Phillips head screwdriver	✕
Open-end spanner	—C 8, 9, 10, 18
Socket spanner/Box spanner	◻ 8, 10, 19, 22

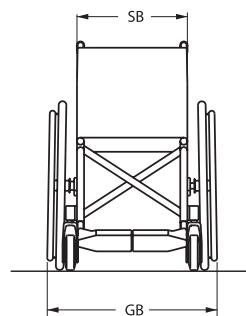
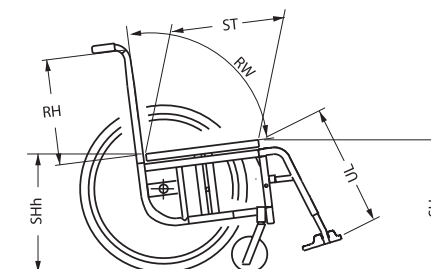

Spare parts and adaptations

All spare parts may be obtained from the Küschall customer service department.

An electronic spare parts catalogue can be found at www.kueschall.com. Only original spare parts may be used. The written authorisation of Küschall AG must be obtained before installing additional adaptations on a Küschall wheelchair.

Fastening with hexagon socket bolts

Hexagon socket bolts are not designed to withstand an excessive application of force. When tightening or undoing a hexagon socket bolt, force should be applied to the nut wherever possible to avoid damaging the bolt.

Tightening and undoing

- Turn the nut using a socket spanner (only use an open-end spanner if there is insufficient space), using the Allen key simply to stop the bolt turning.

Tightening and undoing when no nut is present

If a hexagon socket bolt is screwed directly into a thread, the bolt must be tightened using the Allen key.

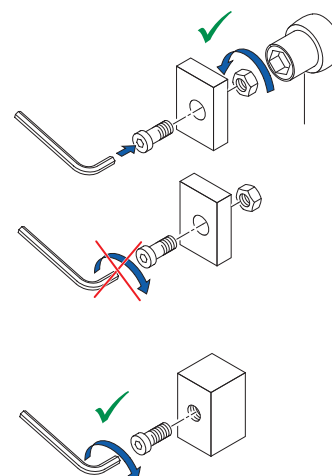



Torque

- All bolts must be tightened with the torque specified in the following instructions.

Checks

Visual check

- Check the entire frame for cracks, especially in the vicinity of joints and weld seams (frame, axle clamp components, back).

Check of the bolts

- Check that all bolts have been tightened with the torque specified in the instructions.



Several bolts are secured with adhesive. If these are loosened, they have to be secured with adhesive again. The most important bolts with adhesive are:

- Central bolt on the cross (high-strength adhesive, 3 Nm)
- Longitudinal stopping bolts on the seat edge (=bolts, which come to rest on either side of the rear seat locking mechanisms when the seat is unfolded) (low-strength adhesive, 13 Nm)

Identifying and repairing faults

Fault	Possible cause	Action
The wheelchair does not travel in a straight line	Incorrect tyre pressure on one rear wheel	Correct tyre pressure
	One or more spokes broken	Replace broken spoke(s)
	Spokes tightened unevenly	Tighten loose spokes
	Front wheel bearings are dirty or damaged	Clean or replace the bearings
	Support bearings in forks faulty	Replace the support bearings
The wheelchair tips too easily	Steering error or trail angle, left and right, uneven	Adjust steering error or trail angle
	Rear wheels are mounted too far forwards	Mount the rear wheels further back
	Backrest angle too large	Reduce backrest angle
The brakes are gripping poorly or asymmetrically	Seat angle too large	Mount the adapter plate lower on the side profile
	Incorrect tyre pressure in one or both rear tyres	Correct tyre pressure
The rolling resistance is very high	Brake setting incorrect	Correct brake setting
	Tyre pressure in rear tyres is too low	Correct tyre pressure
	Rear wheels not parallel	Make rear wheels parallel
	Drum brake set too narrow	Set the drum brake
The front wheels wobble when moving fast	Bearings are dirty or faulty	Replace the bearings
	Too little tension on the clevis pin housing	Tighten the nut on the castor fork slightly
The front wheel is stiff or stuck	Front wheel has worn smooth	Replace front wheel
	Bearings are dirty or faulty	Replace the bearings
The wheelchair is very difficult to unfold	The backrest cover is too tight	Loosen the topmost Velcro band of the backrest cover a little
Left and right side of the wheelchair can be moved in parallel to one another	Longitudinal stopping bolts on the seat edge are loose	Tighten the longitudinal stopping bolts on the seat edge



Frame

- ① Rear frame
- ①a → 13 Nm
- ①b → 7 Nm
- ② Retaining lever
- ②a → 4 Nm
- ③ Cross
- ④ Front frame
- ④a → 13 Nm
- ④b → 7 Nm
- ④c → 7 Nm
- ⑤ Upper connecting tube
- ⑥ Lower connecting tube
- ⑦ Seat locking mechanism
- ⑧ Longitudinal stopping bolts

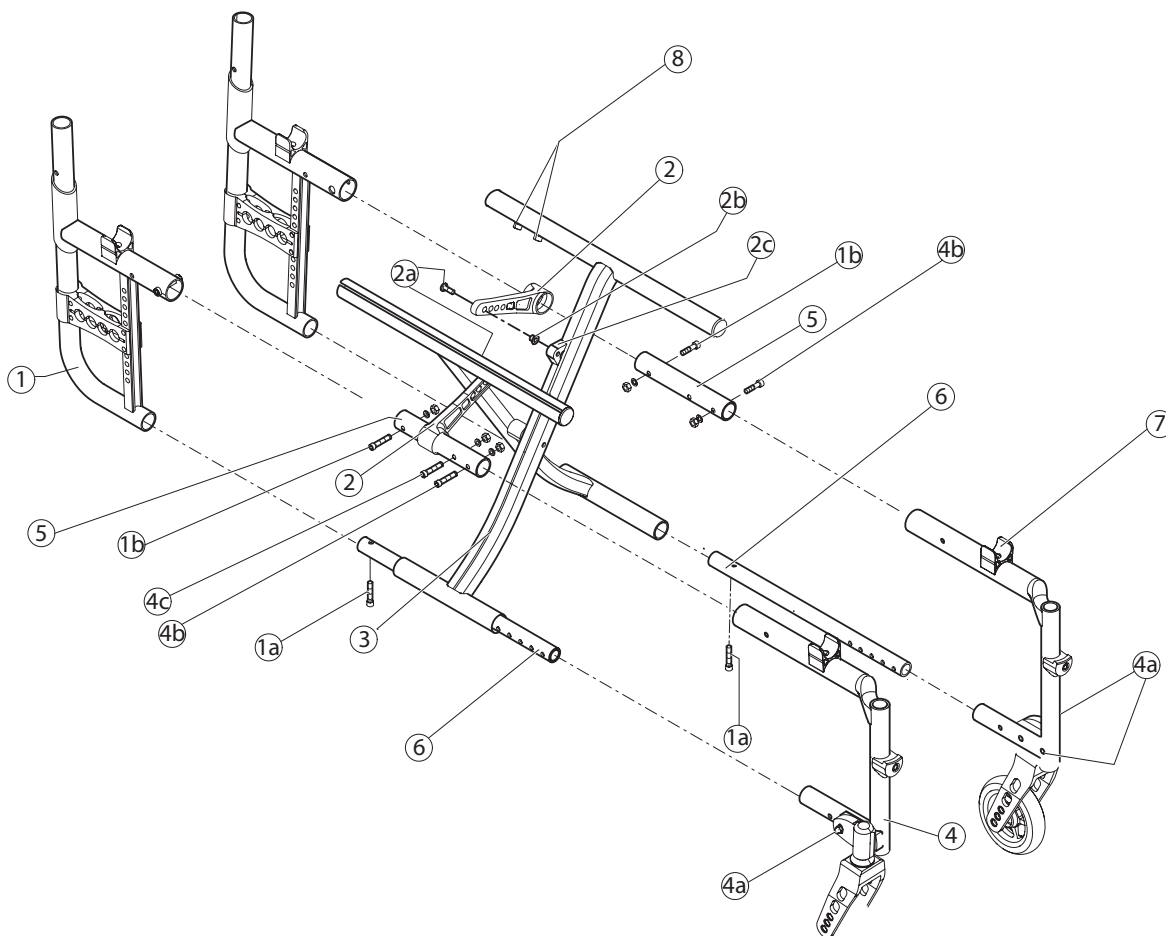
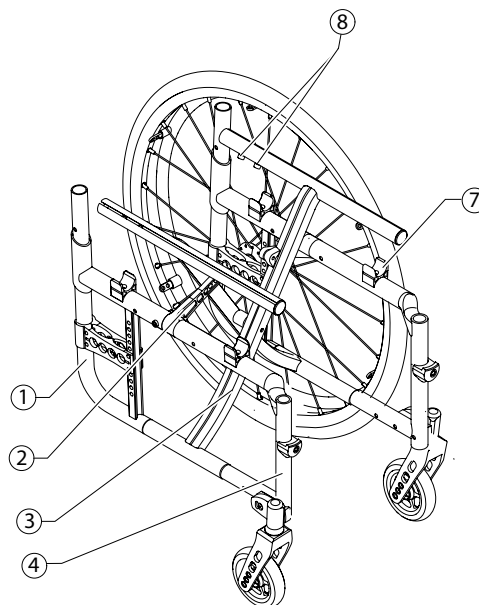



Rear frame

Replacing the rear frame

Difficulty: ●●○

Tool: ● 5 10

- Remove backrest.
- Loosen and remove bolts ①a and ①b.
- Pull out rear frame ① to the back.
- Push the rear frame onto the upper ⑤ and lower ⑥ connecting tubes.
- Reinsert and tighten bolts ①a and ①b.

Front frame

Replacing the front frame

Difficulty: ●●○

Tool: ● 3, 4, 5 10

- Disassemble brakes.
- Loosen and remove bolts ④a and ④b on both sides. (On abduction frames, the connecting tube ⑥ is welded onto the front frame; in this case loosen ①a and ④b.) If a flip to back side rest is fitted, also loosen ④c.
- Pull out front frame ④ to the front.
- Remove seat locking mechanism ⑦ with threaded insert from old front frame and fit it on the new front frame,
→ Chap. Seat; «Turning the seat locking mechanism».
- Push the front frame onto the upper and lower connecting tube.
- Reinsert and tighten bolts ④a, ④b (if required ④c) on both sides.
- Set the castor fork angle,
→ Chap. Front wheels; «Setting the steering error angle».

Retaining lever

Replacing the retaining lever

Difficulty: ●●○

Tool: ● 3, 4, 5 10

- With mudguard or clothes guard, fixed: remove ①a and ④b, with mudguard or side rest, insertable and siderest, foldable: remove ①a and ①b.
- Remove bolt ②a.
- Pull the retaining lever ② from the upper connecting tube ⑤.
- Remove sleeve ②b.
- Push the new retaining lever over the upper connecting tube ⑤.
- Position sleeve ②b with wide edge in joint ②c.
- Secure retaining lever with bolt ②a.
- With mudguard or clothes guard, fixed: reinsert and tighten bolts ①a and ④b, with mudguard or side rest, insertable and side rest, flip to back: reinsert and tighten bolts ①a and ①b.



Seat

Seat height front (SHv)

Options for changing the SHv:

- Replace front wheel with larger or smaller one or fit it at another position on the castor wheel,
→ Chap. Front wheels «Replacing the front wheel».
- Replace castor fork with a larger or a smaller one,
→ Chap. Front wheels; «Replacing the castor fork».
- Fit it high/low with the housing guide «Hemi»,
→ Chap. Front wheels; «Special housing guides».

Seat height front with respect to fork size, castor fork size and position in the fork								
SHv [cm]	Castor fork [inch]							
	4"	4"	5"	5"	6"	6"	8"	8"
41	○3"							
42		○3"						
43/44		○4"	○3"					
45			○4"	○3"				
46			○5"	○4"	○3"			
47				○5"	○4"	○3"		
48/49				○6"*	○5"	○4"	○3"	
50					○6"*	○5"	○4"	○3"
51					○7"*	○6"*	○5"	○4"
52						○7"*	○6"*	○5"
53/54							○7"*	○6"*

(Assumption: Seat depth = 40 cm, seat angle = 5 cm)

fitted high: SHv - 3 cm

fitted low: SHv + 3 cm

* 6" and 7" front wheels cannot be used on the Ultra-Light dynamic frame (80°), if a 2-part angled footrest is fitted.



Seat height rear (SHh)

Options for changing the SHh:

- Replace rear wheel with a larger or a smaller one
- Change the position of the adapter plate, → Chap. Rear wheels.

Seat height rear with respect to the rear wheels and positioning on the frame				
SHh [cm]	Rear wheel size [inch]			
	22"	24"	25"	26"
37	1			
38	2			
39	3	1		
40/41	4	2	1	
42	5	3	2	1
43	6	4	3	2
44	7	5	4	3
45/46	8	6	5	4
47	9	7	6	5
48	10	8	7	6
49		9	8	7
50		10	9	8

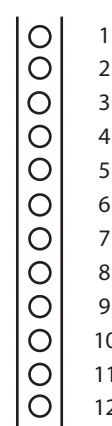

Seat width (SB)

SBs range from 28 - 50 cm.

Once the SB is specified, it is very difficult to change it: the cross struts, backrest cover (on standard backs) and, on some configurations, the foot-rests must be replaced.

Seat depth (ST)

STs range from 32 - 50 cm.

To reduce the ST, the cross struts must be shortened and a new appropriately sized seat cover fitted. At an ST ≥ 40 cm, the frame can be shortened.

To enlarge the ST, new cross struts, a new appropriately sized seat cover and, depending on the ST, a new frame must be installed.



Replacing the seat cover

Difficulty: ●●○

Tool: * 10

- 1 Loosen bolts ① and remove plug ②.
- 2 Remove seat cover including plastic rods.
- Position new seat cover. Adjust seat cover to width SB + 25 mm.
- Retighten bolts ① and plug ②.

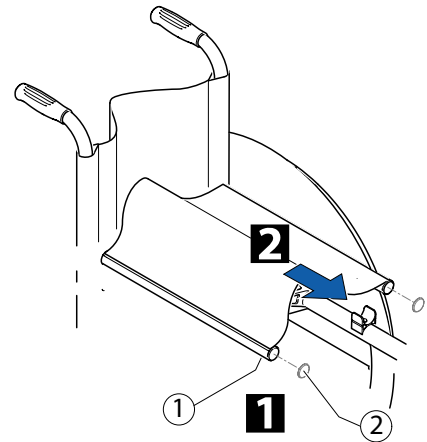

① → 4 Nm

Turning the seat locking mechanism

If the seat edge can be too easily removed from the seat locking mechanisms, either the front two or all four seat locking mechanisms can be rotated by 180°:

Difficulty: ●○○

Tool: ● 3

- Loosen bolt in seat locking mechanism ①.
- Turn seat locking mechanism by 180°.
- Secure bolt with adhesive (low-strength).
- Retighten the bolt.

i Screw out the bolt only to the extent that the seat locking mechanism can be turned as otherwise the threaded insert can move and is then difficult to re-position.

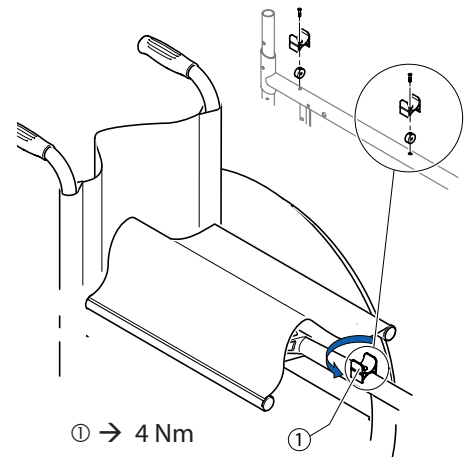

① → 4 Nm



Backrest

Backrest height

The backrest height can be changed by fitting the telescopic tubes into another position in the backrest tubes. If this setting option is insufficient, the telescopic tubes can be replaced.

Adjusting the height of standard backrests

Difficulty: ●○○

Tool: ● 3, 4, 6 ◻ 8, 10

- Push the backrest cover ① upwards and remove the bolt ② on both sides.
- Push the push handles ③ upwards or downwards until you reach the required height. Replace the bolt and tighten.

i If this setting range is insufficient, use new push handle tubes.

i If the backrest height was changed considerably, a new backrest cover may have to be fitted.

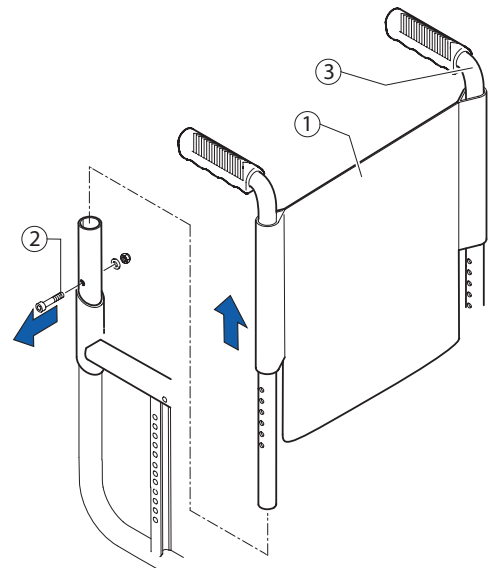

Adjusting the height of Velcro® adjustable backrests

Difficulty: ●○○

Tool: ● 3, 4, 6 ◻ 8, 10

- Remove backrest cover and move the Velcro® bands until bolt ① is visible.
- Remove bolt ① and move the push handle tube to the required height.
- Insert bolt ① into the appropriate hole and tighten.

i If the backrest height is changed considerably, the push handles must be replaced. An additional Velcro® band may have to be fitted or one may have to be removed.

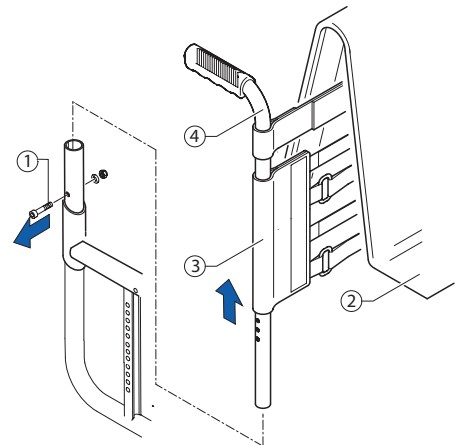



Adjustable-angle backrest

In order to make the backrest angle adjustable, an adjustable-angle backrest can be fitted.

Backrest angle

Position	Deviation from standard backrests	Angle between backrest and seat
1	12°	102°
2	8°	98°
3	4°	94°
4	0°	90°
5	-4°	86°
6	-8°	82°
7	-12°	78°

Fitting an adjustable-angle backrest

Difficulty: ●●○

Tool: ● 3, 4, 5, 8, 10 — C10

Shorter rear frame (variant III) required.

- Push the lower joint pin ② into the rear frame ① and fix it using a bolt.
- Secure backrest tube ⑥ to the upper joint pin ③ using a bolt. Assemble the upper and lower joint pins ③ and ② and secure with bolt ④ (13 Nm).
- Retighten the bolt ④.
- Set the desired backrest angle and secure in the nearest hole using bolt ⑤.
- Push the single Velcro® band ⑧ and then the other Velcro® bands ⑨ and end band ⑩ over the backrest tube ⑥.
- Push the push handle ⑦ into the telescopic tube ⑥ and fix at the required height.
- Secure end band ⑩ on the telescopic tube ⑦ with a bolt.

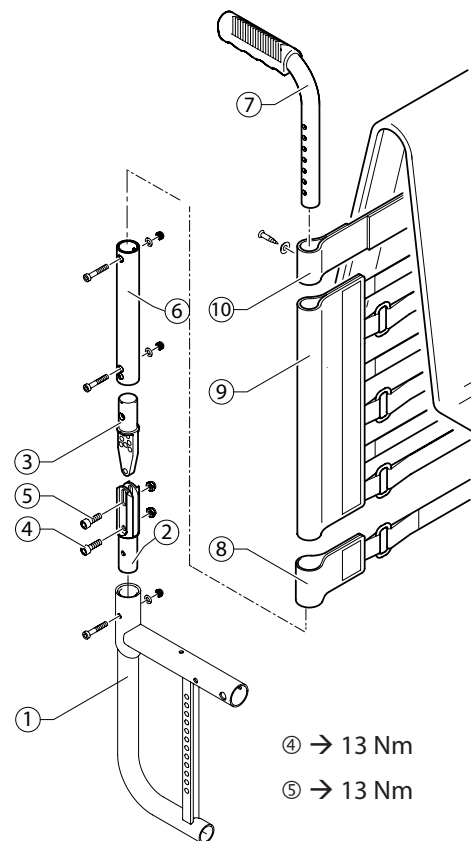



Setting the backrest angle

Difficulty: ●●○

Tool: ● 5 ◻ 10 — C10

- 1 Remove the backrest cushion ② and push the Velcro® bands ③ upwards, until the backrest joint ① is invisible.
- 2 Remove the bolt ④.
- 3 Set the desired backrest angle, insert the bolts ④ in the nearest hole and tighten.
- Retighten the bolt ⑤.
- Perform the same setting on both sides.

Visual check

By looking from the side check that both backrest tubes are level and thus that the same angle has been set on both sides.

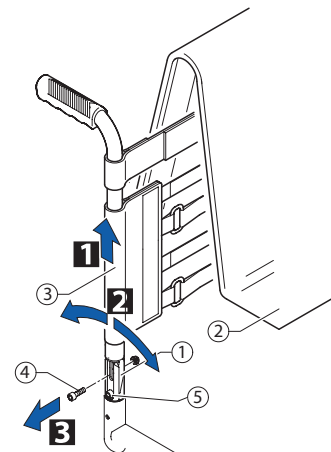

④ → 13 Nm

⑤ → 13 Nm

Fitting the joint for a folding backrest

Difficulty: ●●○

Tool: ● 4, 5 ◻ 10

Shorter rear frame (variant III) required.

- 1 Set the desired backrest angle, insert bolt ① in the nearest position (Pos. 1, 2 or 3) and tighten (13 Nm). (With the curved backrest tubes, other positions can be achieved in addition to the 3 positions specified.)
- Fold down upper joint pin with intermediate backrest tube ②.
- 2 Push the joint housing ③ into the rear frame ④ and fit it using a bolt (13 Nm).

Backrest angle

Position 1 (rear position): 82°, with curved backrest tube 90°

Position 2 (mid position): 86°, with curved backrest tube 94°

Position 3 (front position): 90°, with curved backrest tube 98°

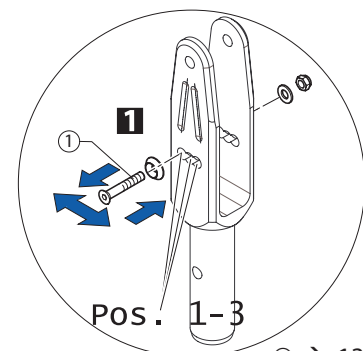

① → 13 Nm

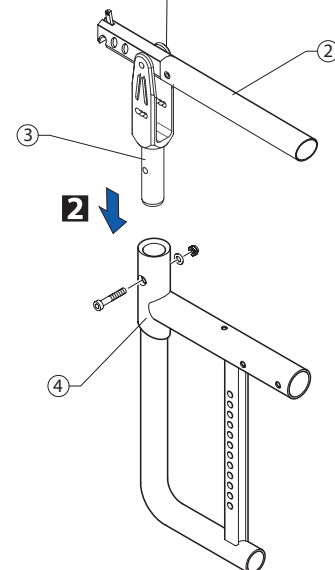



Replacing push handles / push handles and backrest

If the push handles are replaced with a different type of push handles, e.g. height-adjustable ones, it can happen that the rear frame must also be replaced.

Changing the backrest height can also mean that the configuration of the Velcro® bands must be changed.

Fitting standard push handles

Difficulty: ●●○

Tool: ✕ ● 3, 4, 5 ◻ 8, 10

- 1 Secure the telescopic tube ④ to the rear frame ① at the required height.
- 2 Push the backrest bands ② and end band ③ onto the telescopic tube ④, end band first.
- 3 Secure end band ③ on the telescopic tube ④ with a bolt.

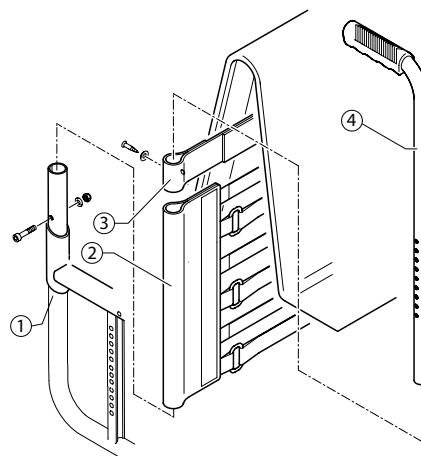

Fitting height adjustable integrated push handles

Difficulty: ●●○

Tool: ✕ ● 3, 4, 5 ◻ 8, 10

Special rear frame required for RH 30 – 46.5 (variant II)

- Push lower telescopic tube ② and upper telescopic tube ③ into one another and insert bolt.
- Secure pre-assembled element (telescopic tubes ② and ③) at the required height on the rear frame ① with a bolt (7 Nm).
- Push the Velcro® bands ④ and end band ⑤ onto the telescopic tubes.
- Using the clamp bolt ⑦ secure the height adjustable push handles ⑥ through the telescopic tube ③.
- Push in push handle completely.
- Secure end band ⑤ on the telescopic tube ③ with a bolt.

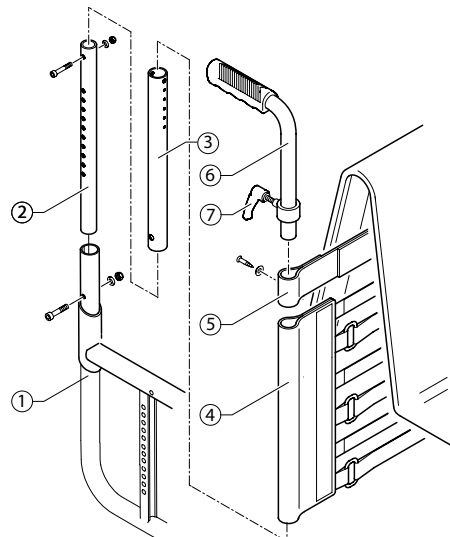



Fitting height adjustable, rear set push handles

Difficulty: ●●○

Tool: ✕ ● 3, 4, 5 ◻ 8, 10

The Velcro® bands may have to be replaced with narrower ones, as space is required to secure the holder on the telescopic tube.

- Secure the telescopic tube ② to the rear frame ① at the required height.
- Press the cover cap ⑥ onto the end of the telescopic tube.
- Push the Velcro® bands ③ onto the telescopic tube.
- Push the holder ⑤ onto the telescopic tube and fix in place by tightening the clamp bolts (13 Nm).
- Fit end band ④ onto the telescopic tube and secure with a bolt.
- Attach protective cushion.

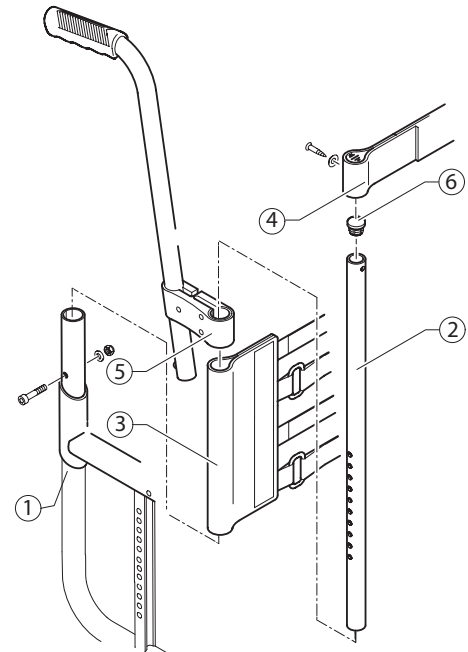

Fitting angle-adjustable backrest with height-adjustable push handles

Difficulty: ●●○

Tool: ✕ ● 3, 4, 5 ◻ 8, 10 — C10

Shorter rear frame (variant III) required.

- Push the lower joint pin ② into the rear frame ① and fix it using the bolts.
- Fit backrest tube ⑥ onto the upper joint pin ③ using bolts. Assemble the upper and lower joint pins ③ and ② and secure with a bolt ④.
- Set the desired backrest angle and secure in the nearest hole using a nut and bolt ⑤.
- Retighten the bolt ④.
- Push the single Velcro® band ⑧ and then the other Velcro® bands ⑨ and end band ⑩ over the backrest tube ⑥.
- Push in push handle completely.
- Using the clamp bolt ⑪ fit the height-adjustable push handles ⑦ through the telescopic tube ⑥.
- Fit end band ⑩ onto the telescopic tube ⑥ with a bolt.

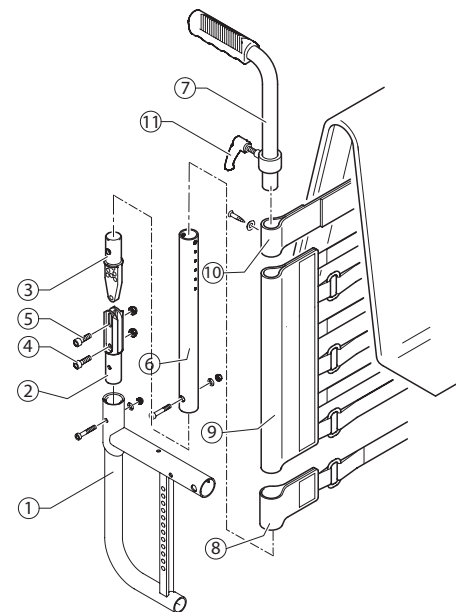

④ → 13 Nm

⑤ → 13 Nm



Backrest

Backrest with adjustable backs with respect to push handles

Backrest height (RH)	Standard push handles	Folding push handles	Height-adjustable integrated push handles				Velcro bands		
	①	②	③	④	③	④	⑤	⑥	
30	S	S	S	XXS	S	XXS	S	4B	S
31.5	S	S	S	XS	S	XS	S	4B	S
33	S	S	S	S	S	S	S	4B	S
34.5	S	S	L	M	S	M	L	4B	S
36	S	S	L	M	S	M	L	4B	S
37.5	S	S	L	M	S	M	L	4B	S
39	S/M	S/M	L	M	S	M	L	4B	M
40.5	S/M	S/M	L	M	S	M	L	4B	M
42	S/M	S/M	L	M	S	M	S	6B	M
43.5	M	M	L	L	L	L	S	6B	M
45	M	M	L	L	L	L	S	6B	M
46.5	M	M	L	L	L	L	L	6B	M
48	M	M	L	L	L	L	L	6B	L
49.5	M	M	L	L	L	L	L	6B	L
51	M	M	L	L	L	L	L	6B	L

Assumption: No stabilising bar fitted

Angle-adjustable backrest with adjustable backs with respect to push handles

Backrest height (RH)	Standard push handles	Folding push handles	Height-adjustable integrated push handles		Velcro bands		
	①	②	③		④	⑤	⑥
30	S	S	S	different for every backrest height	L	1B+2B	S
31.5	S	S	S		L	1B+2B	S
33	S	S	S		S	1B+4B	S
34.5	S	S	L		S	1B+4B	S
36	S	S	L		S	1B+4B	S
37.5	S	S	L		L	1B+4B	S
39	S/M	S/M	L		L	1B+4B	M
40.5	S/M	S/M	L		L	1B+4B	M
42	S/M	S/M	L		L	1B+4B	M
43.5	M	M	L		S	1B+6B	M
45	M	M	L		S	1B+6B	M
46.5	M	M	L		S	1B+6B	M
48	M	M	L		S	1B+6B	L
49.5	M	M	L		L	1B+6B	L
51	M	M	L		L*	1B+6B*	L

Assumption: No stabilising bar fitted

* For RH51 with height-adjustable integrated push handles: ⑤=S, ⑥=2x4B



Foldable angle-adjustable backrest with respect to push handles

Backrest height (RH)	Standard push handles	Folding push handles	Height-adjustable integrated push handles		Velcro bands				
	①	②	③	④	⑤	⑥			
30	S	S	S	different for every backrest height	S	different for every backrest height		S	
31.5	S	S	S		S			S	
33	S	S	S		S			S	
34.5	S	S	S		S		L	2B	S
36	S	S	S		S		L	2B	S
37.5	S	S	S		S		L*	2B	S
39	S	S	L		S		L	2B	M
40.5	S	S	L		S		S	4B	M
42	S	S	L		S		S	4B	M
43.5	M	M	L		S		S	4B	M
45	M	M	L		L		S	4B	M
46.5	M	M	L		L		L	4B	M
48	M	M	L		L		L	4B	L
49.5	M	M	L	L	L	4B	L		
51	M	M	L	L	L	4B	L		

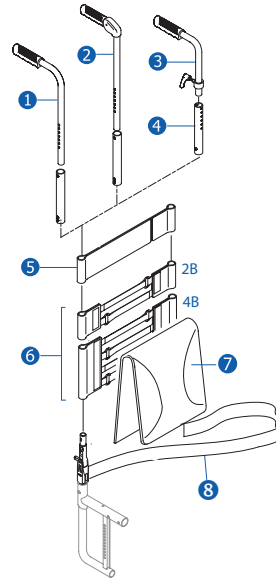

Assumption: No stabilising bar fitted

* For RH37.5 with height-adjustable integrated push handles: ⑤=S und ⑥=2B+4B

Additionally a band ⑧ is fixed close to the backrest joint. The band is of different length according to the seat width (SB).

There are three lengths: SB 28-36 → short,
 SB 38-44 → medium,
 SB 46-50 → long



Legrests

Legrests with angle measurements of 70, 80 and 90° are available.

Replacing the locking mechanism

Difficulty: ●○○

Tool: *10 ● 3

- Screw off unlocking lever ① manually.
- Remove hinge pin ②.
- Loosen bolts ④.
- Remove locking mechanism ③ and replace with a new one.
- Reinsert bolts ④ and tighten.
- Screw in the hinge pin ② again.
- Screw the unlocking lever ① back on manually.

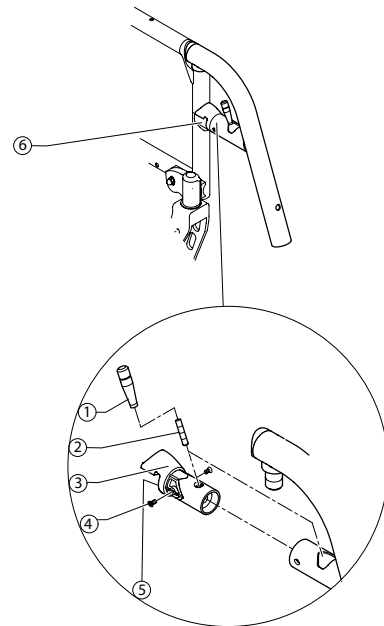

② → 3 Nm

④ → 3 Nm

Setting the locking lever

Difficulty: ●●○

Tool: ● 3, 5

It must be possible to move the unlocking lever ① 1-2 mm freely forward and back, without having to move the bolt ⑤. This guarantees that the bolt is sitting optimally in the counterpiece ⑥. If this free mobility is greater or smaller than specified, the unlocking lever must be reset:

- Screw off the unlocking lever ① manually.
- Loosen the hinge pin ② (do not remove).
- Screw bolt ⑤ in deeper to reduce movement or screw bolt ⑤ further out to increase movement.
- Set it so that the pin can move freely by 1-2 mm.
- Retighten the hinge pin ② again.
- Screw the unlocking lever ① back on manually.



Footrests

One-piece and two-piece footrests are available.

One-piece footrest

Replacing the footplate

Difficulty: ●○○

Tool: ● 4 ⬡ 10

- Loosen bolts ① on both sides.
- Remove footplate ② and replace with a new one.
- Re-insert bolts ① and tighten.

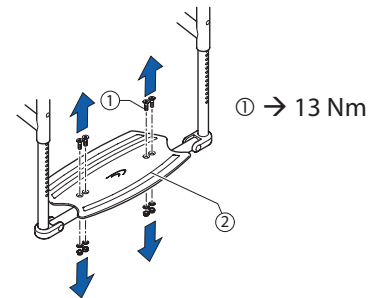

Disassembling/fitting the footrest

Difficulty: ●○○

Tool: ● 4 ⬡ 8

- 1 Remove bolts ① on both sides.
- 2 Pull out the footrest.
- 3 Insert new footrest.
- 4 Tighten bolts ① on both sides at the same height and in the required position.

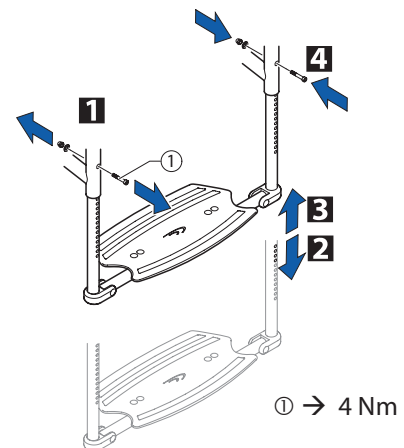

Adjusting the height of the footrest

Difficulty: ●○○

Tool: ● 4 ⬡ 8

- 1 Remove bolts ① on both sides.
- 2 Hold the telescopic tubes ② with both hands and push the footrest into the required position.
- 3 Insert bolts ① into the nearest hole on both sides and at the same height and tighten securely.

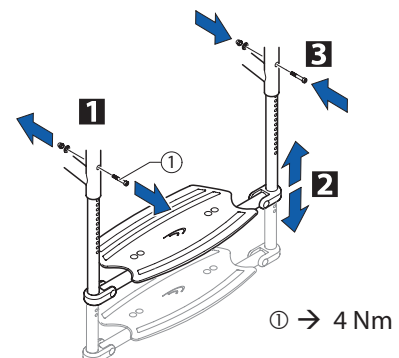



Centring and adjusting the angle

Difficulty: ●○○

Tool: ● 4 ⬡ 10

- Loosen bolts ① and ② slightly.
- 1 Set the same distance from the side tube to the footplate on both sides.
- 2 Set the required footplate incline.
- Re-tighten bolts ① (fixed side of the footplate).
- Turn the little tube ③ on the moving side of the footplate such that it engages properly.
- Tighten bolts ②.

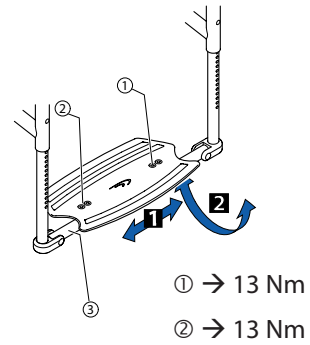

Changing the position of the footrest (set to rear – set to front)

Difficulty: ●○○

Tool: ● 4 ⬡ 10

- 1 Loosen bolts ① on both sides and remove.
- 2 Turn the footplate with the clamp component.
- 3 Re-insert bolts ① and tighten.

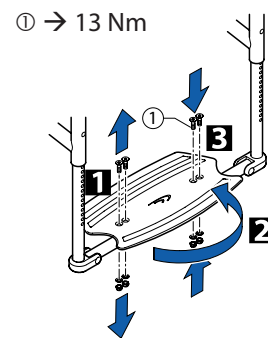



Two-piece footrest

Difficulty: ●○○

Tool: ● 4 ◻ 8

Disassembling/fitting footrests

- 1 Remove bolts ① on both sides.
- 2 Pull out footrests.
- 3 Push the new footplates into the frame and at the required height.
- 4 Insert bolts ① into the nearest hole on both sides and at the required height and tighten.

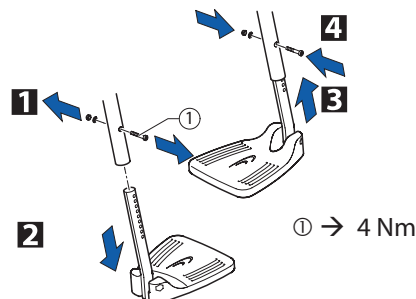

Adjusting the height of the footrests

Difficulty: ●○○

Tool: ● 4, ◻ 8

- Remove bolts ①.
- Push the footplates into the required position.
- Insert bolts ① into the nearest hole on both sides and at the required height and tighten.

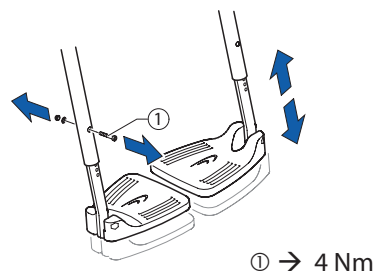

Changing the position of the footrests (set to rear – set to front)

Difficulty: ●○○

Tool: ● 5

- 1 Remove bolts ①.
- 2 Pull the footrests away downwards and replace.
- 3 Re-insert bolts ① and tighten.

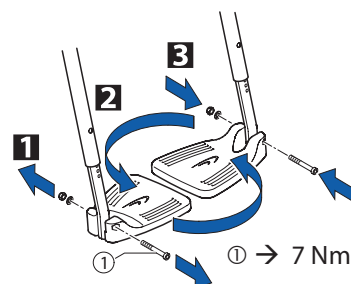

Two-piece footrest, adjustable-angle

Adjusting the angle

Difficulty: ●○○

Tool: ● 5

- 1 Loosen bolt ①.
- 2 Change the angle of the footrest until it reaches the required position.
- Retighten bolt ①.

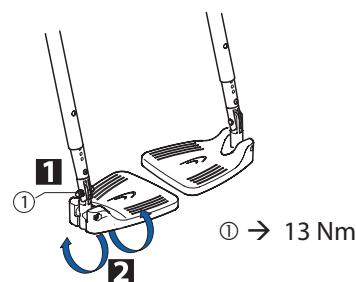



Sideparts

Clothes guard/mudguard

Fitting the clothes guard/mudguard

Difficulty: ●●○

Tool: ● 3 ○ 8

- 1 Fit side fastenings ① onto the frame.
- 2 Fit clothes guard/mudguard ② with bolts and nuts onto the side fastenings (4 Nm).



CAUTION!

Fit the mudguard such that it is positioned either < 8 mm or > 25 mm above the tyres, to avoid the risk of trapping one's fingers.

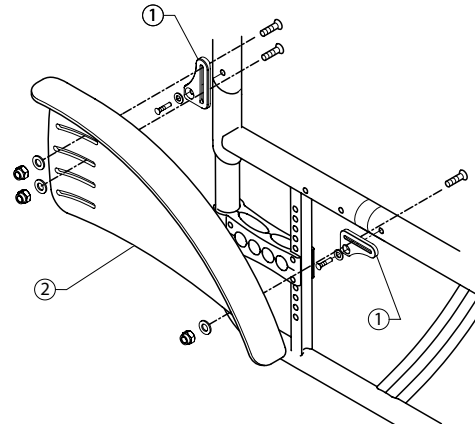

Adjusting the clothes guard/mudguard

Difficulty: ●●○

Tool: ● 3 ○ 8

- 1 Loosen bolts ①. Move the clothes guard/mudguard ②.
 - Retighten bolts ①.
- or
- 2 Loosen and remove bolts ①.
 - 3 Re-fit clothes guard/mudguard ② in another position.

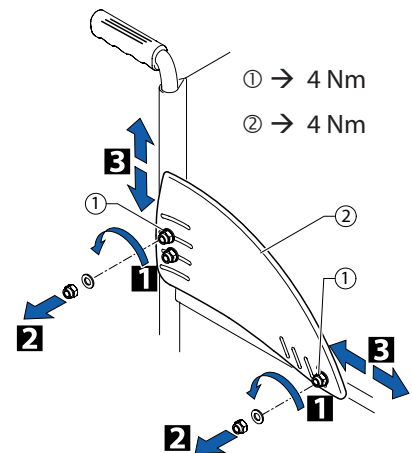

Fitting and adjusting the removable mudguard

Difficulty: ●●○

Tool: ● 3, 4, 5 ○ 10

- 1 Fit side fastening element ① with bolts ②a and ②b.
- 2 Insert mudguard ③ in the side fastening element ①. Adjust the height by loosening the three bolts on the end stop ④.
- 3 If the edge of the mudguard does not run evenly over the tyre, loosen bolts ⑤/⑥ and push the mudguard ③ into the required position. Retighten bolts ⑤/⑥.



CAUTION!

Fit the mudguard such that it is positioned either < 8 mm or > 25 mm above the tyres, to avoid the risk of trapping one's fingers.

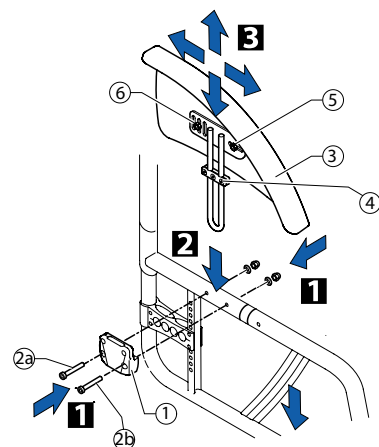

②a → 4 Nm

②b → 7 Nm

⑤ → 7 Nm

⑥ → 7 Nm



Siderests

In general a torque of 7 Nm is used to fit the side rests.

Fitting a flip to back side rest in the frame colour

Difficulty: ●●○

Tool: ● 3, 4, 5 ⬡ 10

- Fit the side fastening element with bolt 1a.
- For bolt 1b, bore a hole with a diameter of 6 mm through the front frame (hole already made in the connecting tube) and fit bolt 1b.
- Screw the sleeve and bolt ② onto the rear fastening element ③.
- Fit rear fastening element ③ and clip ⑦ loosely with bolts ⑧ and sleeves ⑨ (normal rear frame: 1.7 cm beneath the upper edge of the frame reinforcement, on a shortened rear frame, directly flush with the upper edge of the frame reinforcement).
- Mount the side rest ④, position rear fastening element ③ precisely.
- Attach the wedge ⑤ and headless bolt ⑥.

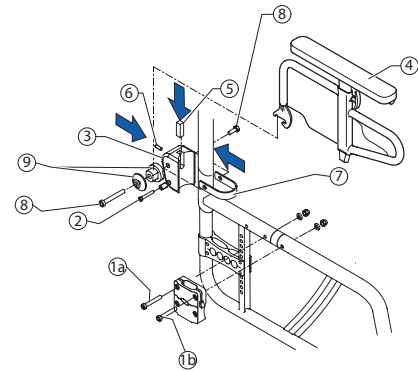

i The sleeves ⑨ are different for flip to back side rest in frame colour and flip to back side rest with engagement mechanism.

i To enlarge the distance between the wheels additionally, a different adapter sleeve, which is mounted from the inside, has to be applied.

Fitting flip to back side rest with locking mechanism

Difficulty: ●●○

Tool: ● 3, 4, 5 ⬡ 10

- Fit the side fastening element with bolt 1a.
- For bolt 1b, bore a hole with a diameter of 6 mm through the front frame (hole already made in the connecting tube) and fit bolt 1b.
- Screw the sleeve and bolt ② onto the rear fastening element ③.
- Fit rear fastening element ③ and clip ⑦ loosely with bolts ⑧ and sleeves ⑨ (normal rear frame: 1.7 cm beneath the upper edge of the frame reinforcement, on a shortened rear frame, directly flush with the upper edge of the frame reinforcement).
- Mount side rest ④, position rear fastening element ③ precisely.
- Attach the wedge ⑤ and headless bolt ⑥.

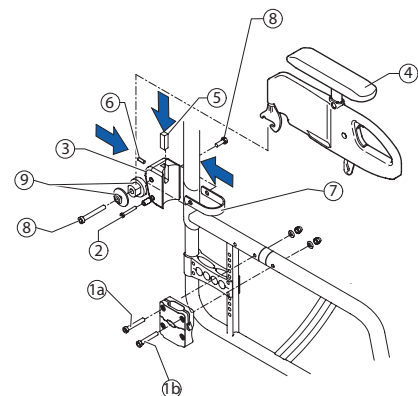

i The sleeves ⑨ are different for flip to back side rest in frame colour and flip to back side rest with engagement mechanism.

i To enlarge the distance between the wheels additionally, a different adapter sleeve, which is mounted from the inside, has to be applied.



Fitting side rest insertable, continuously height-adjustable

Difficulty: ●●○

Tool ● 4, 5 □ 10

- 1 Fit the side fastening element with bolts ① and ②.
- 2 Insert side rest into the fastening element.
- Adjust height by adjusting the clamp component.

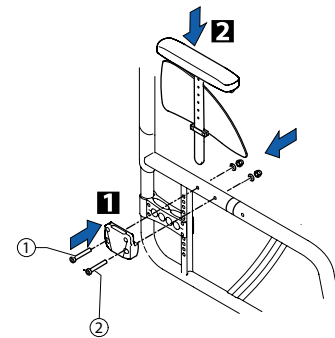

① → 4 Nm

② → 7 Nm

Fitting a simple swivelling armrest

Difficulty: ●●○

Tool ● 4, 5

- 1 Fit the rear fastening element.
- 2 Insert the armrest.
- Adjust height by adjusting the bolt in the tube of the armrest.

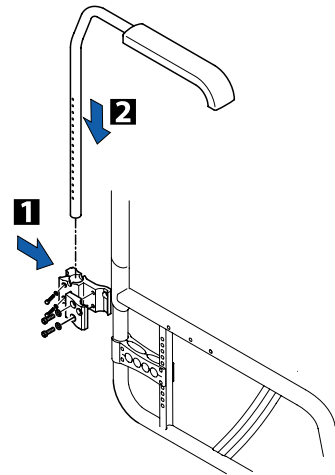



Size of the clothes guard/mudguard

The clothes guard and mudguard can be adjusted to suit the height of the rear wheel exactly. Two sizes of each are available. For the removable carbon mudguard there is an additional size (XL) for the two smallest rear seat heights (SHh).

Clothes guard mounted fix:

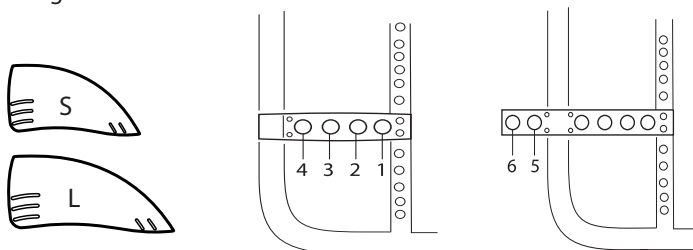

Clothes guard with respect to the position of the rear wheels with standard adapter plate (Pos. 1 to 4) or rear wheel extension (Pos. 5 and 6)

SHh	Rear wheel 22"						Rear wheel 24"						Rear wheel 25"						Rear wheel 26"					
	1	2	3	4	5	6	1	2	3	4	5	6	1	2	3	4	5	6	1	2	3	4	5	6
38	L	L	L	S	S	S	-	-	-	-	-	-	-	-	-	-	-	-	-	-	-	-	-	
39	L	L	L	S	S	S	L	L	L	L	L	L	-	-	-	-	-	-	-	-	-	-	-	
40	L	L	L	S	S	S	L	L	L	L	L	L	-	-	-	-	-	-	-	-	-	-	-	
41	L	L	S	S	S	S	L	L	L	S	L	L	L	L	L	L	L	-	-	-	-	-	-	
42	L	L	S	S	S	S	L	L	L	S	L	L	L	L	L	L	L	L	L	L	L	L	L	
43	L	S	S	S	S	S	L	L	L	S	L	L	L	L	S	S	S	L	L	L	L	S	S	
44	L	S	S	S	S	S	L	L	L	S	S	S	L	L	L	S	S	S	L	L	L	L	S	S
45	S	S	S	S	S	S	L	L	S	S	S	S	L	L	L	S	S	S	L	L	L	S	S	S
46	-	-	-	-	-	-	L	L	S	S	S	S	L	L	L	S	S	S	L	L	L	S	S	S
47	-	-	-	-	-	-	L	S	S	S	S	S	L	L	S	S	S	S	L	L	L	S	S	S
48	-	-	-	-	-	-	L	S	S	S	S	S	L	L	S	S	S	S	L	L	L	S	S	S
49	-	-	-	-	-	-	-	-	-	-	-	-	L	S	S	S	S	S	L	L	S	S	S	S
50	-	-	-	-	-	-	-	-	-	-	-	-	L	S	S	S	S	S	L	L	S	S	S	S



Sideparts

Mudguard mounted fix:

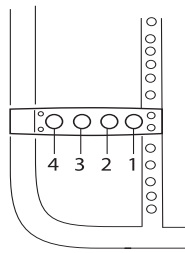
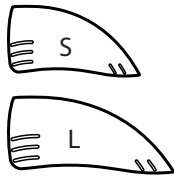

Mudguard (mounted fix) with respect to the position of the rear wheels with standard adapter plate (Pos. 1 to 4)

SHh	Rear wheel 22"				Rear wheel 24"				Rear wheel 25"				Rear wheel 26"			
	1	2	3	4	1	2	3	4	1	2	3	4	1	2	3	4
41	L	L	S	S	L	L	L	L	L	L	L	L	-	-	-	-
42	L	L	S	S	L	L	L	L	L	L	L	L	L	L	L	L
43	L	S	S	S	L	L	L	L	L	L	L	L	L	L	L	L
44	L	S	S	S	L	L	L	S	L	L	L	L	L	L	L	L
45	S	S	S	S	L	L	S	S	L	L	L	L	L	L	L	L
46	-	-	-	-	L	L	S	S	L	L	L	S	L	L	L	L
47	-	-	-	-	L	S	S	S	L	L	S	S	L	L	L	S
48	-	-	-	-	S	S	S	S	L	S	S	S	L	L	L	S
49	-	-	-	-	-	-	-	-	S	S	S	S	L	L	S	S
50	-	-	-	-	-	-	-	-	S	S	S	S	L	L	S	S

Mudguard removable:

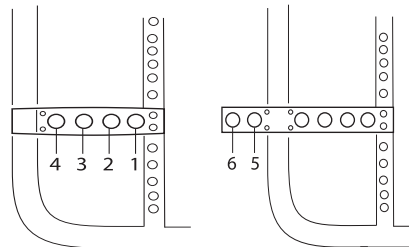
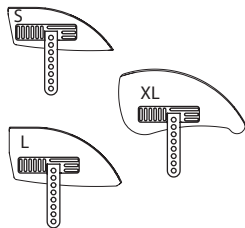

Mudguard (removable) with respect to the position of the rear wheels with standard adapter plate (Pos. 1 to 4) or rear wheel extension (Pos. 5 and 6)

SHh	Rear wheel 22"						Rear wheel 24"						Rear wheel 25"						Rear wheel 26"					
	1	2	3	4	5	6	1	2	3	4	5	6	1	2	3	4	5	6	1	2	3	4	5	6
38	L	L	L	L	S	S	-	-	-	-	-	-	-	-	-	-	-	-	-	-	-	-	-	-
39	L	L	L	L	S	S	XL	XL	XL	XL	L	L	-	-	-	-	-	-	-	-	-	-	-	-
40	L	L	L	L	S	S	XL	XL	XL	XL	L	L	-	-	-	-	-	-	-	-	-	-	-	-
41	L	L	S	S	S	S	XL	L	L	L	L	L	XL	XL	XL	XL	L	L	-	-	-	-	-	-
42	L	L	S	S	S	S	L	L	L	L	L	L	XL	XL	XL	XL	L	L	XL	XL	XL	XL	L	L
43	L	S	S	S	S	S	L	L	L	L	L	L	XL	L	L	L	S	S	XL	XL	XL	XL	S	S
44	L	S	S	S	S	S	L	L	L	S	S	S	L	L	L	L	S	S	XL	XL	XL	XL	S	S
45	S	S	S	S	S	S	L	L	S	S	S	S	L	L	L	L	S	S	XL	XL	L	L	S	S
46	-	-	-	-	-	-	L	L	S	S	S	S	L	L	L	S	S	S	L	L	L	L	S	S
47	-	-	-	-	-	-	L	S	S	S	S	S	L	L	S	S	S	S	L	L	L	S	S	S
48	-	-	-	-	-	-	S	S	S	S	S	S	L	S	S	S	S	S	L	L	L	S	S	S
49	-	-	-	-	-	-	-	-	-	-	-	-	S	S	S	S	S	S	L	L	S	S	S	S



Front wheels

Replacing the front wheel

Difficulty: ●○○

Tool: ● 3

- 1 Remove bolts ①, pull out wheel axle ②.
- 2 Remove front wheel ③ and replace with a new one or move to a new position.
(In the case of the Starec wheel, skater wheel, 3" sports wheel and the 5" soft roll wheel, 2 sleeves ④ must be pushed onto the axle. These sleeves are already in place on the low-resistance wheel, the sports wheels and the pneumatic wheels.)
- 3 Re-insert axle ② and tighten bolt ①.

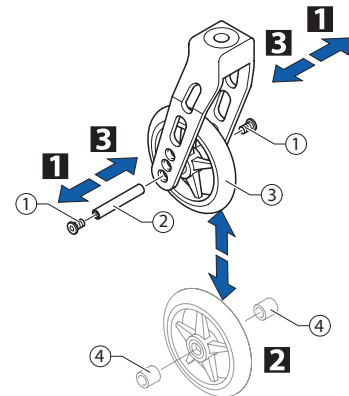

① → 4 Nm

Function check

There must be no play in the wheel but it must turn easily.

Castor fork

Replacing the castor fork

Difficulty: ●●○

Tool: ● 3 19

- 1 Remove bolts ①, wheel axle ② and front wheel ③.
- 2 Remove nuts ④ and pull the castor fork ⑤ from the clevis pin.
- Replace castor fork ⑤ and secure with nut ④ such that the fork has no play.
- Re-insert the front wheel.



CAUTION!
Do not overtighten nut ④, as this can damage the fork bearing.

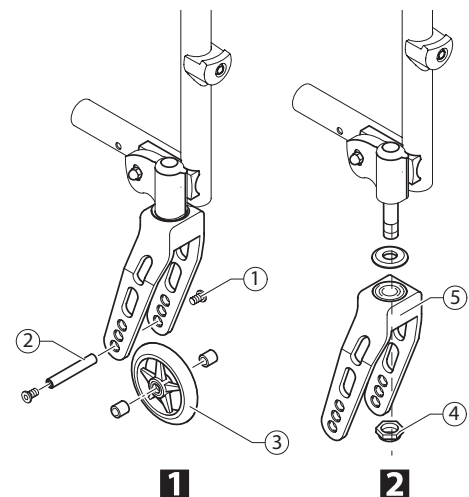

Function check

Tip the wheelchair backwards 90° so that it is lying on the backrest and rear wheels.

Turn the fork up (A) and allow it to swivel down.

The fork is adjusted correctly if it just passes the lowest point and stops there (B).

If the fork moves back when in its lowest position (C), it has not been tightened enough. There is a risk that the front wheels will start to wobble when travelling at high speeds.

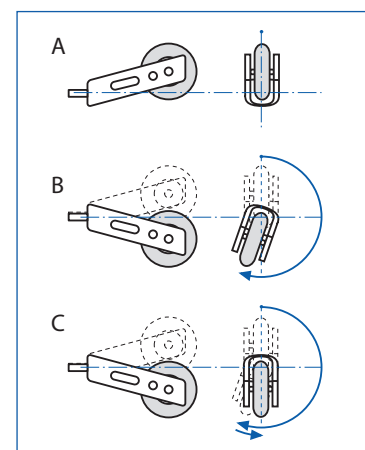



Setting the steering error angle

Difficulty: ●●○

Tool: ●5 ○10

- Loosen bolts ① and nuts ②.
- Hold spirit level against the clevis pin housing ④.
- Turn the bolt ③ until the clevis pin housing is ④ vertical.
- Retighten bolts ① and nuts ②.



CAUTION!

It is important that the settings on the left and right are precisely the same.

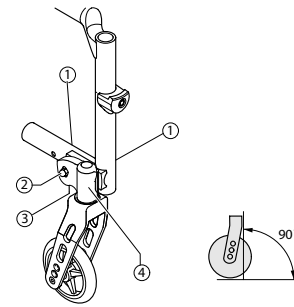

① → 13 Nm

Correcting the trail angle

Difficulty: ●●○

Tool: ●5 ○10

- Loosen bolts ① and nuts ②.
- Remove clevis pin housing ⑤.
- Attach adjustment template ③/④ (for toe-out: insert template at the bottom ③, for toe-in: insert template at the top ④).
- Fit clevis pin housing ②.
- Set the angle, → Chap. Front wheels; «Setting the steering error angle», «Correcting the trial angel».

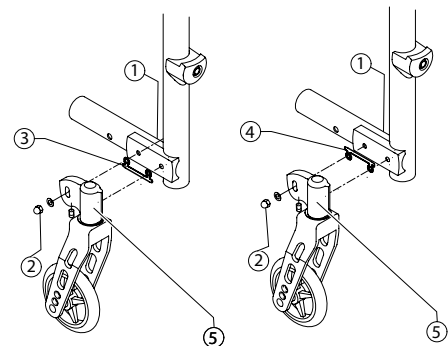

Special housing guides

Fitting special housing guide for smaller SHv (housing guide, fitted high)

Difficulty: ●●○

Tool: ●5 ○10

- Remove clevis pin housing ②.
- Remove standard housing guide.
- Attach bolt ③.
- Fit special housing guide ① «high».
- Fit clevis pin housing ②.
- Set the angle,, → Chap. Front wheels; «Setting the steering error angle», «Correcting the trial angel».

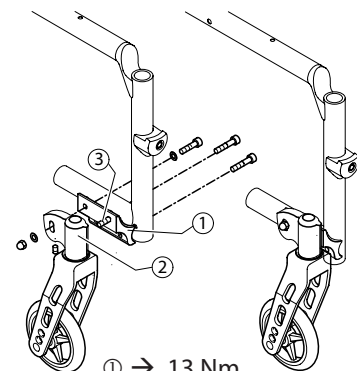

① → 13 Nm

② → 13 Nm

Fitting special housing guide for larger SHv (housing guide, fitted low)

Difficulty: ●●○

Tool: ●5 ○10

- Remove clevis pin housing ②.
- Remove standard housing guide.
- Fit special housing guide ① «low».
- Fit clevis pin housing ②.
- Set the angle, → Chap. Front wheels; «Setting the steering error angle», «Correcting the trial angel».

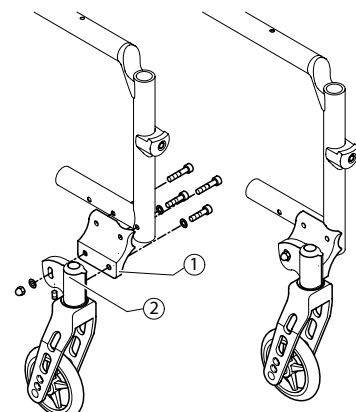

Rear wheels

Adjusting the seat height rear

Difficulty: ●○○

Tool: ● 5 ○ 10, 19, 22

- Loosen the bolt of the adapter sleeve ② and bolts ①.
- Remove bolts ③ and move the adapter plate ④ into the required position.
- Insert bolts ③ at the appropriate height.
- Insert the bolt of the adapter sleeve ②.
- Tighten bolts ① and ③.
- Tighten the bolt of the adapter sleeve ②.
- Perform the same setting on both sides.

i After the SHh is changed, the steering error angle must be checked → Chap. Front wheels; «Setting the steering error angle», «Correcting the trial angle» and with a wheel camber of 3° the angle of the rear wheels must also be checked, → Chap. Rear wheels; «Changing the wheel camber».

i After the SHh is changed, distance sleeves may also have to be fitted in order to increase the distance to the rear wheels.

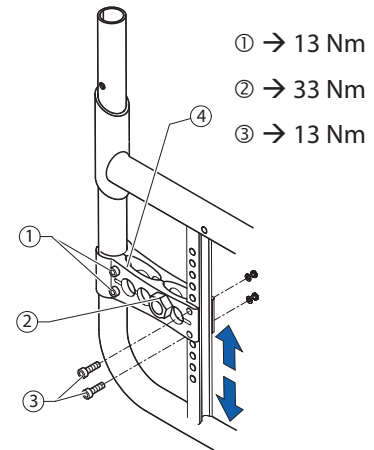

- ① → 13 Nm
- ② → 33 Nm
- ③ → 13 Nm

Tipping stability

The tipping stability is influenced by the rear wheel being fitted further forward or further backward on the adapter plate. The further back the adapter sleeve is fitted, the greater the tipping stability of the wheelchair.

If the rear wheel is to be fitted even further back, a rear wheel extension can be fitted to increase the tipping stability even more.

Adjusting the position of the rear wheel on the adapter plate

Difficulty: ●○○

Tool: ○ 19, 22

- 1 Remove the adapter sleeve ①.
 - 2 Set the adapter sleeve ① at the required position in the adapter plate ② and tighten the nut securely.
- Perform the same setting on both sides.

i Brakes and mudguard must be repositioned if the position of the rear wheel is changed.

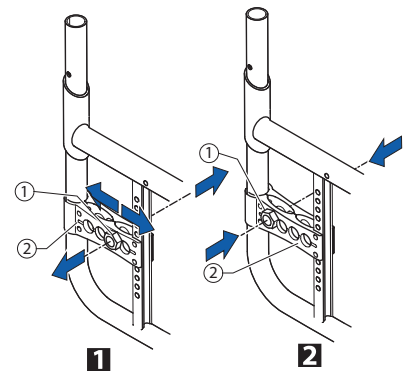

- ① → 33 Nm
- ⑤ → 13 Nm

Fitting the rear wheel extension

Difficulty: ●○○

Tool: ● 5 ○ 10, 19, 22

- 1 Remove the adapter sleeve ① and adapter plate ②.
- 2 Position the adapter plate for the rear wheel extension ③ at the required height and tighten securely on the counterpiece ④ using bolts ⑤ and ⑥. Set the adapter sleeve ① at the required position in the adapter plate ③ and tighten the nut securely.

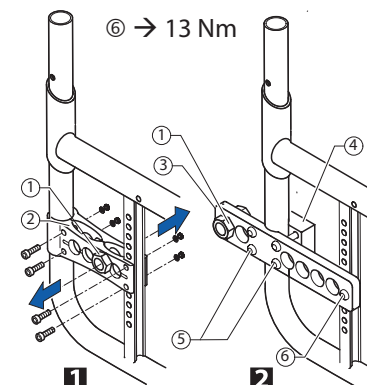

- ⑥ → 13 Nm

Rear wheels

Wheel camber

A wheel camber of either 0° or 3° is possible.

Changing the wheel camber

Difficulty: ●●●

Tool:  18  19, 22

The wheel camber is changed by replacing the adapter sleeve:

- 1 Remove adapter sleeve ②.
- 2 Insert new adapter sleeve ③ at the required position on the adapter plate ① and tighten securely.

 To fit a 3° sleeve, the side of the sleeve must be aligned vertically using a spirit level to ensure that the rear wheels are parallel to one another.

Visual check

The gap between the wheel and the frame at the front must be the same on both sides.

The gap between the wheels at the front and rear at axle level must be the same.

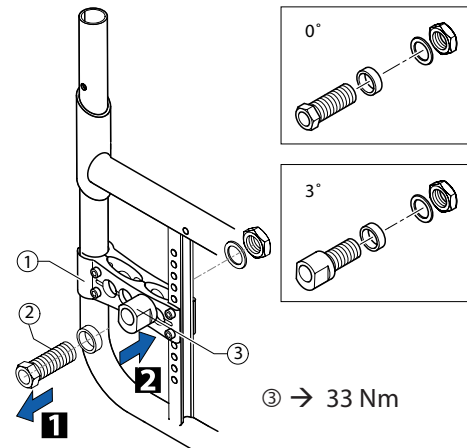

Adapter plate for drum brake

Fitting the adapter plate for the drum brake

Difficulty: ●○○

Tool:  5  10

- 1 Remove the adapter sleeve ① and adapter plate ②.
- 2 Position the adapter plate for the drum brake ③ at the required height and tighten it securely on the counterpiece ④ using bolts ⑤ and ⑥, → Chap. Brakes; «Fitting the drum brake».

Distance sleeves for rear wheels

If new side parts are fitted on a wheelchair (side rests, arm rests, clothes guard or mudguard), the gap between the rear wheels must be increased by attaching additional distance sleeves. Likewise, distance sleeves may also have to be fitted if other rear wheels are fitted or if the seat height rear is altered.

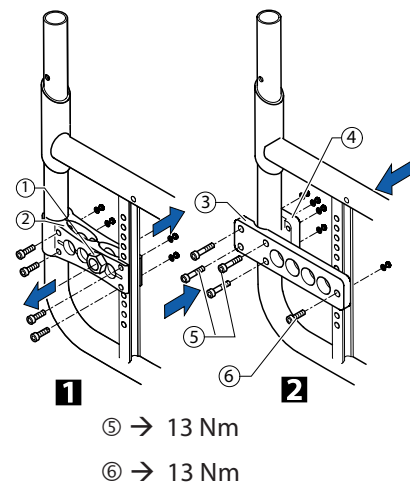



Brakes

Parking brakes

Fitting/adjusting the parking brake

Difficulty: ●○○

Tool: ● 5 ⬡ 10



CAUTION!

The parking brakes must be adjusted whenever the rear wheels are replaced.

- Check the air pressure in the rear wheels.
- 1 Secure the brake holder loosely to the frame using bolt ①.
- 2 Push the brakes ② into the brake holder and position, then tighten the bolt ①.



The brake is set correctly if the brake rod presses into the tyre by no more than 4 mm when the brake is applied and the tyres are properly pumped.

Visual check

Check that the parking brakes are positioned correctly. The brake is set correctly if the brake shoe depresses the tyre by no more than 4 mm when the brake is applied. (In the case of active brakes and standard brakes this will be the case when the brake shoe is approx. 25 mm away from the tyre when released.)

Function check

Place a weighted wheelchair with parking brake engaged facing uphill and then facing downhill on a ramp with an incline of 7°. The wheelchair should not move.

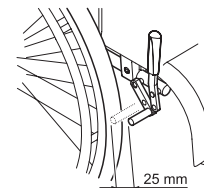
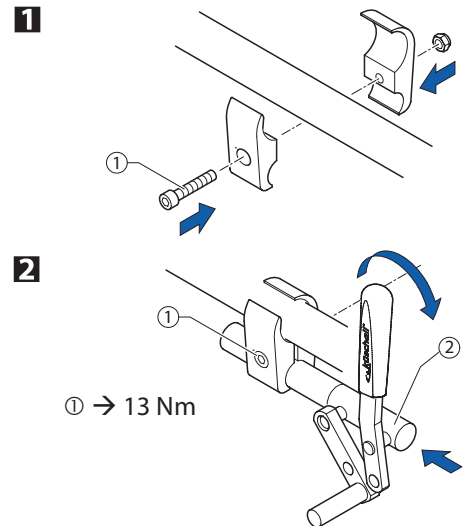



Drum brake

Fitting the drum brake

Difficulty: ●●●

Tool: ● 4, ✕ — C 9 ◻ 10, 22

- Remove standard adapter plate and replace with adapter plate for drum brake, → Chap. Rear wheels; «Fitting adapter plate for drum brake».
- 1 Fit the drum brake plate ① and rotary fixing ② to adapter plate ③. Connect the drum brake plate and rotary fixing with bolt ④.
- 2 Fit brake lever ⑤ on the push handle and secure Bowden cable ⑥ with fixing set.

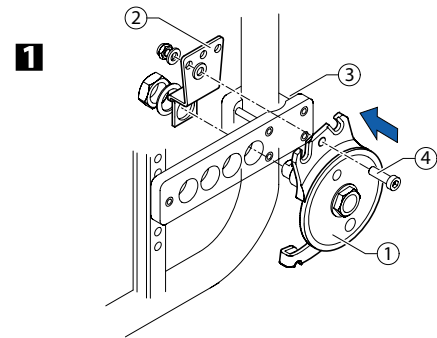

④ → 7 Nm

Setting the drum brake

Difficulty: ●●○

Tool:

- Tighten or loosen the brake by turning the setting sleeve ⑦.
- If the setting sleeve cannot be turned any further, demount brake cable ⑥, loosen clamp bolt ⑧ using the screwdriver and retighten the cable.

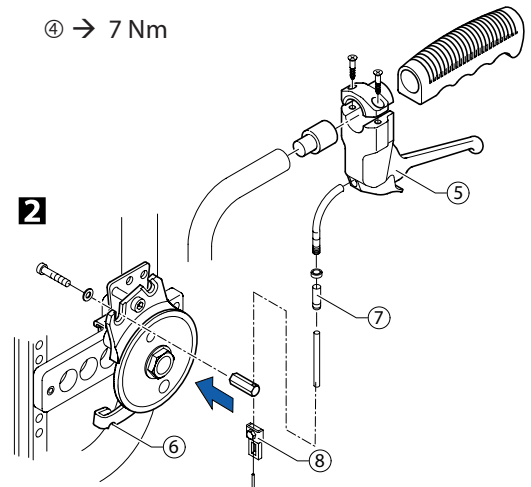



Options & accessories

Antitipper

Fitting an antitipper

Difficulty: ●○○

Tool: ● 5 □ 10

- Secure adaptation support ① with bolt ② onto the adapter plate ③.

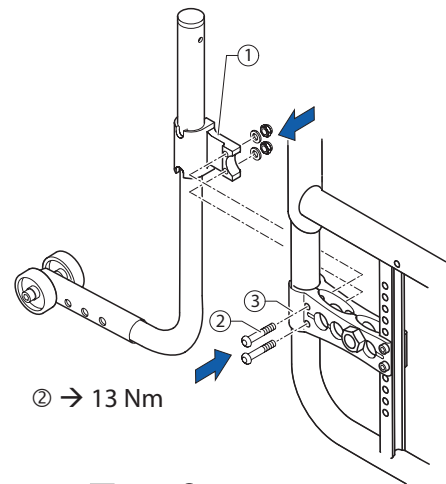

Height adjustment

Difficulty: ●○○

Tool: ● 4 □ 8

- 1 Loosen bolt ② and remove the upper end ③ of the antitipper and the holder. Remove the sealing cap ① (e.g. push it out through the tube using the screwdriver).
 - 2 Loosen bolt ⑦ of the antitipper tube and push sleeve ⑥ into the correct position.
 - 3 Screw bolt ⑦ in half way, position spring ⑧ in sleeve ⑥ and screw bolt ⑦ completely into the tube.
 - 4 Put all the parts of the antitipper back together; in doing so pull spring ⑧ apart, e.g. using a wire hook, and secure it with the top bolt ②.
- Set the antitipper parallel to the wheel chair and tighten the bolts.

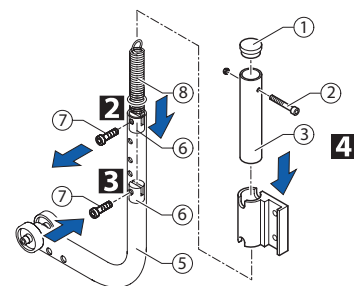
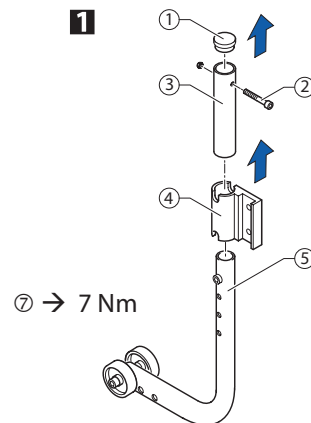

Function check:

The distance between the antitipper and the ground must be 40 - 60 mm. It must be easy to fold up the antitipper.

Tip the wheelchair backwards using the antitipper until the axle is perpendicular to the antitipper's point of contact with the ground. In this position, the distance between the rear wheel and the ground must be at least 50 mm.

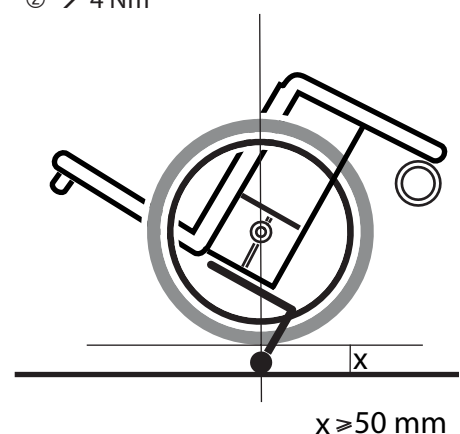



Tipper aid

Fitting the tipper aid

Difficulty: ●○○

Tool: ● 5 ◻ 10

- Secure adaptation support ① with bolt ② onto adapter plate ③. Push in spring clip ④ and push the tipper aid into the adaptation support.
- Make sure that the spring clip is correctly engaged in the adaptation support.

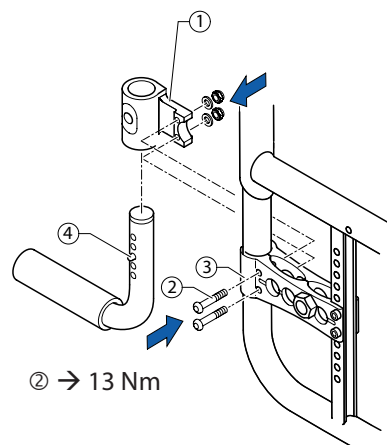

Height adjustment

Difficulty: ●○○

- To adjust the height, remove cap ⑤ and, e.g. using a screwdriver, compress the spring ④ inside the tube and push into the required position.

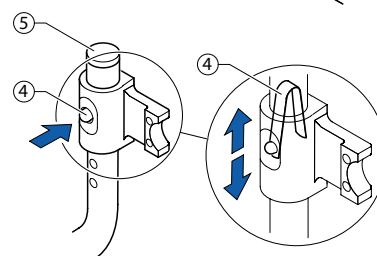

Cane holder

Fitting a cane holder

Difficulty: ●○○

Tool: ● 5 ◻ 10

- Secure adaptation support ① with bolt ② onto adapter plate ③. Push in spring clip ④ and push the cane holder into the adaptation support.
- Make sure that the spring clip is correctly engaged in the adaptation support.

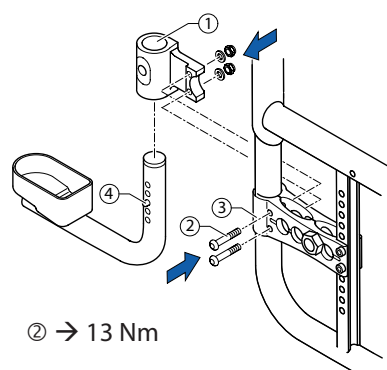

Height adjustment

Difficulty: ●○○

- To adjust the height, remove cap ⑤ and, e.g. using a screwdriver, compress spring ④ inside the tube and push into the required position.

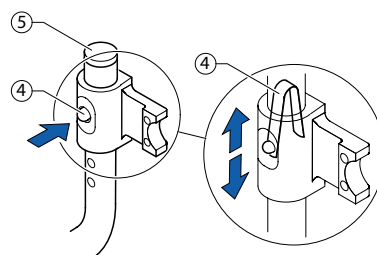



Transit wheels

Fitting transit wheels

Difficulty: ●○○

Tool: ● 5, ◻ 10

- Secure adaptation support ① with bolts ② onto adapter plate ③. Push in spring clip ④ and push the transit wheel into the adaptation support.
- Make sure that the spring clip is correctly engaged in the adaptation support.

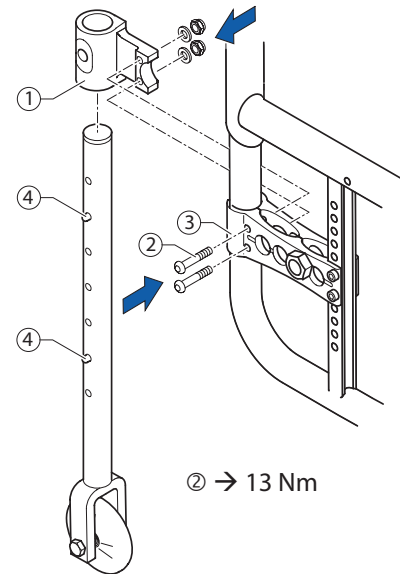

Height adjustment

Difficulty: ●○○

- To adjust the height, remove cap ⑤ and, e.g. using a screwdriver, compress spring ④ inside the tube and push into the required position..

i To bring the transit wheels into the upper or lower position, the spring clip must be pressed in.

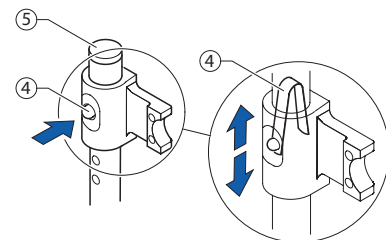

Küschall AG
Benkenstrasse 260
CH-4108 Witterswil
kueschall@invacare.com
www.kueschall.com

Service Manual Compact
ENGLISH | 2011-07

küschall® distributors

Belgium & Luxemburg: Invacare nv • Autobaan 22 • B-8210 Loppem

Tel: (32) (0)50 83 10 10 • Fax: (32) (0)50 83 10 11 • belgium@invacare.com

Danmark: Invacare A/S • Sdr. Ringvej 37 • DK-2605 Brøndby

Tel: (45) (0)36 90 00 00 • Fax: (45) (0)36 90 00 01 • denmark@invacare.com

Deutschland: Invacare Aquatec GmbH • Alemannenstraße 10 • D-88316 Isny

Tel: (49) (0)75 62 7 00 0 • Fax: (49) (0)75 62 7 00 66 • info@invacare-aquatec.com

Deutschland: Ulrich Alber GmbH • Vor dem Weissen Stein 21 • D-72461 Albstadt-Tailfingen

Tel: (49) (0)74 32 2006 0 • Fax: (49) (0) 74 32 2006 299 • info@ulrich-alber.de

European Distributor Organisation: Invacare • Kleiststraße 49 • D-32457 Porta Westfalica

Tel: (49) (0)57 31 754 540 • Fax: (49) (0)57 31 754 541 • edo@invacare.com

España: Invacare SA • c/Areny s/n • Polígon Industrial de Celrà • E-17460 Celrà (Girona)

Tel: (34) (0)972 49 32 00 • Fax: (34) (0)972 49 32 20 • contactsp@invacare.com

France: Invacare Poirier SAS • Route de St Roch • F-37230 Fondettes

Tel: (33) (0)2 47 62 64 66 • Fax: (33) (0)2 47 42 12 24 • contactfr@invacare.com

Ireland: Invacare Ireland Ltd • Unit 5 Seatown Business Campus • Seatown Road • Swords • County Dublin – Ireland

Tel : (353) 1 810 7084 • Fax: (353) 1 810 7085 • ireland@invacare.com

Italia: Invacare Mecc San s.r.l. • Via dei Pini 62 • I-36016 Thiene (VI)

Tel: (39) 0445 38 00 59 • Fax: (39) 0445 38 00 34 • italia@invacare.com

Nederland: Invacare BV • Celsiusstraat 46 • NL-6716 BZ Ede

Tel: (31) (0)318 695 757 • Fax: (31) (0)318 695 758 • nederland@invacare.com • csede@invacare.com

Norge: Invacare AS • Grensesvingen 9 • Postboks 6230 • Etterstad • N-0603 Oslo

Tel: (47) (0)22 57 95 00 • Fax: (47) (0)22 57 95 01 • norway@invacare.com • island@invacare.com

Österreich: Invacare Austria GmbH • Herzog Odilostrasse 101 • A-5310 Mondsee

Tel.: (43) 6232 5535 0 • Fax.: (43) 6232 5535 4 • info@invacare-austria.com

Portugal: Invacare Lda • Rua Estrada Velha • 949 • P-4465-784 Leça do Balio

Tel: (351) (0)225 1059 46/47 • Fax: (351) (0)225 1057 39 • portugal@invacare.com

Sverige & Suomi: Invacare AB • Fagerstagatan 9 • S-163 91 Spånga

Tel: (46) (0)8 761 70 90 • Fax: (46) (0)8 761 81 08 • sweden@invacare.com • finland@invacare.com

Switzerland: Invacare AG • Benkenstrasse 260 • CH-4108 Witterswil

Tel.: (41) (0)61 487 70 80 • Fax.: (41) (0)61 487 70 81 • switzerland@invacare.com

United Kingdom: Invacare Limited • Pencoed Technology Park,

Pencoed, Bridgend CF35 5HZ • Switchboard Tel: (44) (0)1656 776 200, Fax: (44) (0)1656 776 201 •

Customer services Tel: (44) (0) 1656 776 222 • Fax: (44) (0) 1656 776 220