

# Quick Guide

# Unipro Laptimer

# 3004A

Version 1.00

Go faster faster

**UNIPRO ApS**

VIBORG HOVEDVEJ 24

DK-7100 VEJLE

DENMARK

Tel.: +45 75 85 11 82

Fax: +45 75 85 17 82

[www.uniproLaptimer.com](http://www.uniproLaptimer.com)

[mail@uniproLaptimer.com](mailto:mail@uniproLaptimer.com)



<b>Introduction</b> .....	<b>3</b>
<b>Get ready to go!</b> .....	<b>4</b>
Do you have the necessary accessories? .....	4
Installation.....	5
Display unit .....	5
Main box .....	5
RPM sensor.....	8
Receivers .....	8
AMB Loop receiver .....	8
Magnet receiver .....	9
Infrared receiver .....	9
Wheel sensor kit.....	10
The sensor disc.....	10
The wheel sensor .....	11
Basic functions and setup.....	12
Display buttons .....	12
Receiver type .....	13
Stripe setup .....	13
Magnet count .....	13
Magnet delay.....	14
More settings.....	14
<b>Practice and race using the basic functions</b> .....	<b>15</b>
Operating modes .....	15
First lap mode .....	15
Running mode.....	16
Pit mode .....	16
Clear all laps .....	17
<b>Take advantage of the advanced features</b> .....	<b>17</b>
Measure and set the wheel circumference .....	17
Analyse your data .....	17
Data Analyser .....	18
Transferring data from the Laptimer to the Data Analyser is easy.....	18

## Introduction

Thank you for trusting us to deliver the most advanced Laptimer on the market.

The Unipro Laptimer has several unique features and will measure every piece of information with a speed and accuracy you have only dreamt about! It really enables you to use your Laptimer as a tool to go faster, faster.

We did all we could to make your investment as future proof as possible and you should be able to enjoy it in many years to come. With the unique possibility to expand it later, with accessories like Data Analyser, printer and speed kit, your investment is even safer.

If you have a special request either for new accessories or for a new feature, please let us know. We constantly try to develop our products with the most useful features so you can use the Laptimer to go faster, faster but we always appreciate good ideas from the users of our products.

If you have any problems or questions regarding your Unipro Laptimer we will make sure to give you the necessary support.

Please e-mail your questions to [support@uniprolaptimer.com](mailto:support@uniprolaptimer.com) or contact your local dealer.

Good luck on the tracks!

UNIPRO ApS  
Viborg Hovedvej 24  
DK-7100 Vejle  
Denmark  
Web: [www.uniprolaptimer.com](http://www.uniprolaptimer.com)  
E-mail: [mail@uniprolaptimer.com](mailto:mail@uniprolaptimer.com)

## Get ready to go!

In this chapter, we will give you the most necessary information about what to do before you can start using your Laptimer. If you are an experienced user, looking for exact information, you may want to jump to the reference manual.

### ***Do you have the necessary accessories?***

If you have bought the basic package you should have following parts to your Laptimer:



**Main Box**



**Display Unit**



**Receiver – Loop, Magnet or IR**



**RPM Sensor**

You may also have bought any of these extra accessories:



**Speed Kit**

## Installation

Your Laptimer is a precision instrument and you should take the necessary time to ensure correct installation. A basic rule is to start from the sensors and go back to the Laptimer, never the other way. If cables are too long, they should always be looped at the end near the Laptimer. Use plenty of strips to fix the cables to the frame.

### DISPLAY UNIT

The Display Unit is mounted on the steering wheel. Due to the ultra thin Display Unit, you will not have any problems with regulations.

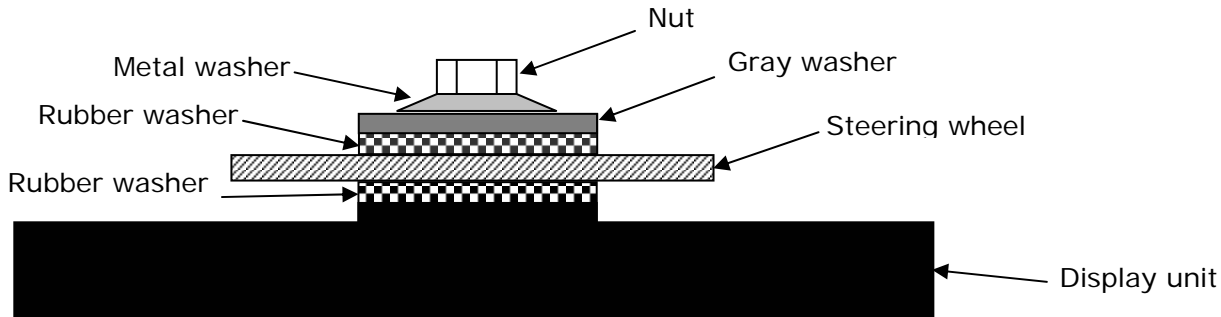

**Figure 1. Display unit mounted on steering wheel**



**First, the Display Unit is mounted on the steering wheel.** Choose a hole that gives a good placement at the top of the steering wheel. On some steering wheels, it is necessary to make the hole a little bigger. Remove the nut, the gray washer and *one* of the two black rubber washers. These parts are mounted on the back side of the steering wheel, as shown in figure 1.

**It is important to keep the right order of the washers.**

Please follow this sequence:

Nut – metal washer – gray plastic washer – black rubber washer – steering wheel – black rubber washer – Display Unit.

Tighten the nut when the display is straight and centered in the steering wheel. This picture shows the correct mounted Display Unit.



### MAIN BOX

The main box is mounted behind the front cover. The following picture is showing the main box and its components.

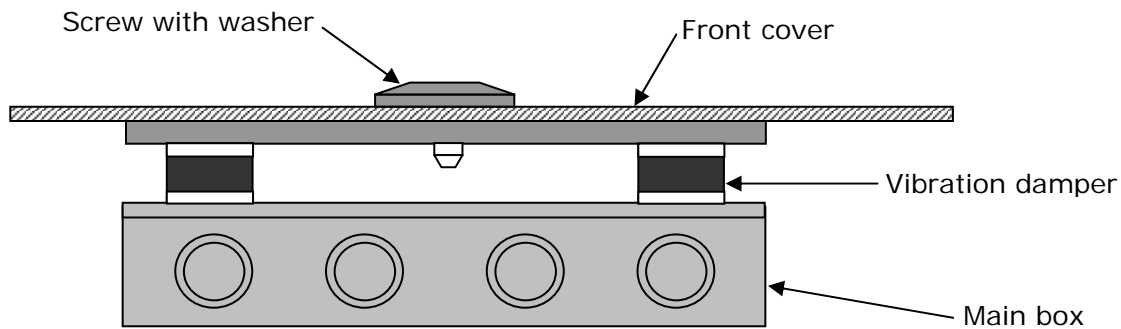

**Figure 2. Main Box with fittings**



**The main Box is mounted behind the front cover.**

First, a 6.5 mm hole is drilled in the cover. Some karts have a recess in the coat suitable for drilling the hole in. If you press hard on the sticker, you can see where to drill the hole. It is a good idea to look from the back before drilling!

**Use the enclosed umbracho screw**

The enclosed screw is screwed through the front coat to ease the mounting of the main box. Use a 5 mm umbracho.





**Make sure that the cable for the Display Unit is pointing upwards.**

The Main Box is held with one hand and the umbracho screw is tightened with the other hand. The cable for the Display Unit must be pointing **upwards**. Make sure the box is placed straight before tighten the screw hard.

The picture shows the Main Box after it is correctly mounted behind the front cover. With the Display Unit and the Main Box correctly mounted, you connect the Main Box and the Display Unit, and start to install the different sensors.

**Cable from the Main Box to the Display Unit.**

The cable for the Display Unit is now routed from the Main Box, along the steering column, to the connector on the Display Unit. Tighten the connector hard, but only use your fingers.



**Make sure the cable aren't squeezed.**

It is very important that the cable cannot be squeezed, even at full swing of the steering wheel. Make a loop on the cable and strip it to the steering column. Test by turning the steering wheel all the way to both sides and feel if the cable at any points feels tight.



## RPM SENSOR

The RPM sensor comes standard with every Unipro Laptimer. We use an active sensor to ensure the best possible signal from all kind of engines. Mount the sensor with care. You do not want it to fall off during a race. If that happens, the Laptimer will turn itself off after 5 minutes and you will no longer be able to see your lap times.



### **Mount the sensor with at least two strips.**

The RPM sensor is mounted in the middle of the ignition cable with at least two strips.

The ignition on a gokart is the worst source of electrical noise and it is therefore a good idea to keep the RPM cable away from any other cables.

Please do not let the RPM cable touch the cylinder or the cylinder head because it can tear the isolation and shield and cause disturbance. The most important issue is to separate the RPM cable from the ignition cable just after the sensor. This is clearly shown on the picture. Do **not** let

the two cables run together!

The cable is mounted in the connector marked **RPM** on the main box. Tighten the connector hard with your fingers.

## RECEIVERS

The Unipro Laptimer supports all kind of receivers. The different receivers are good for different things. If the track has a loop, we recommend using the Loop Receiver.

### **AMB Loop receiver**



### **Mounting the Loop receiver.**

The Loop receiver is mounted as low as possible on the left side of the seat. Drill a 6.5 mm hole from the inside of the seat. The distance from the underside of the Loop receiver to the asphalt must not exceed **100 mm**.

The Loop receiver is mounted parallel with the seat and needs to point backwards against the rear axle. Make sure, that nothing comes between the receiver and the track.

### **Use plenty of strips to secure the cable to the Main Box.**

When the receiver is mounted, the cable is fixed to the middle of the kart, all the way to the Main Box. Use plenty of strips to secure the cable.

The cable is mounted in the connector named **RECV 1** on the Laptimer. Tighten the connector hard with your fingers.



## Magnet receiver



### Mounting the magnet receiver.

The best place to mount the magnet receiver is lengthwise on the bottom plate. Measure and drill the hole from the backside. The most important issue is to minimize the vibrations to the receiver. The most common placement of the magnet receiver is at the very front of the bottom plate, with the cable facing forward.

The distance between the receiver and asphalt **must not exceed 50 mm.**

### Make sure that the cable is fixed properly.

Lead the cable up on the back side of the front cover and into the Main Box. It is important that the cable is fixed properly. We recommend that you use strips to fix the cable to the front cover.

The cable is mounted in the connector marked **RECV 1** on the Main Box. Tighten the connector hard with your fingers.



## Infrared receiver



### Mounting the Infrared receiver.

The best place to mount the infrared receiver is behind the front cover. Measure and drill the hole from the side. The most important issue is to mount the receiver horizontal.

Remember to place the infrared transmitter at the same height as the infrared receiver at least 3 meters from the track.

**Make sure that the cable is fixed properly.**

Lead the cable up on the back side of the front cover and into the Main Box. It is important that the cable is fixed properly. We recommend that you use strips to fix the cable to the front cover.

The cable is mounted in the connector marked **RECV 2** on the Main Box. Tighten the connector hard with your fingers.



WHEEL SENSOR KIT

The wheel sensor kit is used for many of the advanced features in the Laptimer. For instance speed, tire wear counters, lap length and more.

**The sensor disc**

The sensor disc is mounted on the front wheel with pressure on in most of the corners on the track. On most tracks this will be the left front wheel. But it is always best to count the corners of the track, and then choose the appropriate wheel.



Dismount the wheel and put the centering bush in the inner ring of the bearing.



The sensor disc is placed over the centering bush and it is held firmly down. Then tighten the three small screws that fixes the sensor disc to the wheel. Tighten the three screws hard, so the



sensor disc doesn't go loose when you're driving. After the sensor disc is mounted, the centering bush is removed again. The wheel is now ready for mounting again.

## The wheel sensor



The sensor fitting is mounted in a suitable hole in the stub axle. Depending on the kart model, it can be necessary to drill a hole in the stub axle.

If you mount the fitting so the edge is 35-40 mm from the sensor disc, you will be able to make some adjustment on the sensor without having to move the fitting.

Mount the sensor in the fitting so the distance between the sensor and the sensor disc is between 3 and 10 millimeters.

If you experience problems with the speed, this distance is the first thing to check!



The cable is fixed to the frame in a nice large curve so the wheel can turn without the cable being caught or tightened.

Remember to make the loop large enough to allow adjustment of the sensor when you change the front width of the kart.

Fix the cable to the frame with strips all the way to the Main Box. The cable is mounted in the connector named **WHEEL** on the Main Box. Tighten the connector hard

with your fingers.

## Basic functions and setup

We have put a lot of experience and effort into making the Display Unit very easy to operate on the track and in the pit. The feed back we get from drivers and teams using the Unipro Laptimer tells us that we have succeeded. Here you can get an overview over the functions on the Display Unit.

### DISPLAY BUTTONS

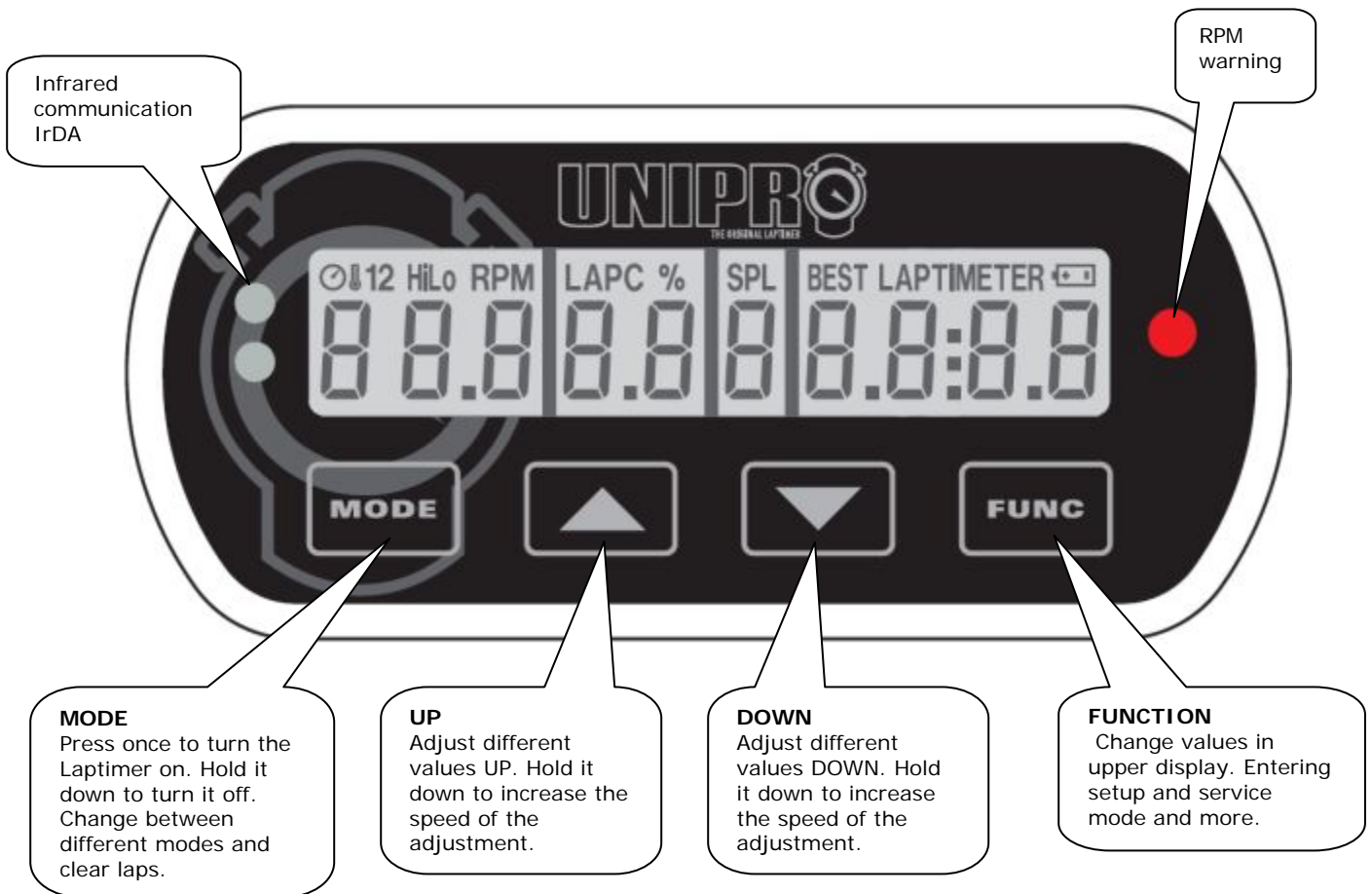

### BASIC SETUP

Go to setup mode, and make sure that the basic settings match your actual setup. You enter setup mode this way:

1. Press MODE to turn on the Laptimer
2. Press and hold FUNC to enter setup mode
3. Press MODE to browse through the different setup screens



You can read about all the setup screens in the reference manual. Here we will introduce you to the ones you need to know to get started.

## Receiver type



**This is the receiver type screen.**

The Unipro Laptimer can use all types of receivers. You can choose between IR (infrared), Loop (AMB active loop) and Stripe (magnets).

Use the  and  buttons to choose the receiver type connected to the Laptimer. **If you use a loop or infrared receiver, you can skip the explanation about stripe setup!**

## Stripe setup



**This is the stripe setup screen.**

If the receiver type is set to Stripe (magnets) this is the next step. It is the most important setup before you start driving on a new track. You need to set two values. The number of magnets from the pit to the finish line (2 in this example)

and the total number of magnets on the track (3 in this example).



Press  to set the two values (see the next two screens and the example with a typical track).

## Magnet count



**Set the total number of magnets on the track.**

When you press  from the stripe setup screen, you can edit the total number of magnets on the track. You can choose between 1 and 8 magnets. If you don't know the number of magnets, you can set the Laptimer to use only one magnet and then drive one lap. Then you can see how many times the Laptimer triggers.

Use the  and  buttons to adjust the total number of magnets.

When the correct number of magnets are entered, press  to edit the number of magnets from the pit to the finish line (See the next screen).

## Magnet delay



### Set the number of magnets from the pit to the finish line.

This is the number of magnets you need to delay when going from the Pit to the finish line. In this example, you need to pass two magnets when going out from the Pit. This means, that on the out lap (or first lap) the Laptimer ignores the first two magnets and then start the Laptimer when passing the third one.

Use the  and  buttons to adjust the magnets delay.

Press  to save and return to the stripe setup screen.

## More settings

If you want to get the full benefit of your Laptimer, we recommend that you use some of the more advanced features and accessories. The most used accessories are:

- Speed kit, which enables you to use speed and tire wear counters
- Data Analyser to view, print and analyse your data

We will get back to this later in the Quick Guide, and you can read all about it in the Reference Manual. With the settings mentioned above, you can start to use your Laptimer, getting precise lap times and RPM values.



## Practice and race using the basic functions

Now you can start using your Laptimer. The Laptimer have some different operating modes. We have already told you about the setup mode. To use the basic functions of the Laptimer, you need to know these three modes:

- First lap mode – the Laptimer always starts in this mode
- Running mode – the Laptimer shifts to running mode when passing the finish line
- Pit mode – Enter pit mode by pressing MODE from First lap or Running mode

After reading the information about the three modes, you can use the basic functions of your Laptimer in practice and race. When you are familiar with these functions we recommend that you start to take advantage of the more advanced functions – these will really help you to improve your lap times.

### ***Operating modes***

#### FIRST LAP MODE



When the Laptimer is turned on with the **MODE** button, it starts up in first lap mode. This is the part of the race going from the pit to the finish line for the first time.

It will always start from the last lap shown in the Laptimer, so you will never “overwrite” anything when turning the Laptimer on.

If you are not in first lap mode when the engine is started, the Laptimer will automatically change to first lap mode when it detects a signal from the RPM sensor. This way, you cannot drive around in pit mode, and think you are getting lap times. It is however possible to change back to pit mode when the engine is running!

The “-2-” is telling how many magnets you need to pass before the finish line. This is the so-called stripe delay. It is possible to manual adjust this delay in first lap mode. If driving with Loop or IR receiver, this part of the display is blank.

When passing the finish line for the first time, the Laptimer change to running mode.



## RUNNING MODE

The Laptimer will automatically turn to running mode when you pass the finish line.



When the finish line is passed for the first time, the display shows 0:00:00 to indicate that the timer is started.

All data are updated in the display every 0.5 seconds. In the display set-up you can define which values you want to show in the lower part during the race. You can choose which data to show in the upper display with the **FUNC** button.

The upper part of the display will always show one of the data not shown in the lower display, lap number and lap time. Small icons will help you identify the value shown. Indication of the best lap is done with the **BEST** icon above the lap time.

## PIT MODE



Pit mode is for analysing the data stored in the Laptimer.

Press **MODE** from either first lap mode or running mode to enter pit mode.

When entering pit mode, the Laptimer jumps to the best lap. In this example, the best lap is lap #12. From this point, you can go two ways: If you press **▲** you will go to the next lap. If you press the **▼** button, the Laptimer jumps to lap # 1.

The **BEST LAPTIME** icon at the top indicates the best lap time. The **FUNC** button changes the data shown in the upper display. Pressing **FUNC** several times changes between the high (maximum) and the low (minimum) data values stored.

## CLEAR ALL LAPS



Clearing all laps and data in the Laptimer is easy!

Pressing and holding the **MODE** button during power-on, clears all the data stored in the Laptimer. You have to confirm it by pressing the **FUNC** button.

After doing clear laps, the Laptimer starts in firstlap mode ready to drive again.

No settings are cleared, only the laps! We recommend clearing the Laptimer after each run. If you have too many laps in the Laptimer, it will get harder to analyse your data.

Transfer the data to the Data Analyser before you clear the laps.

## **Take advantage of the advanced features**

When you are familiar with the basic functions of your Laptimer, it's time to really use the Laptimer to improve your lap times.

The most important of the advanced features are:

- Speed kit
- Data Analyser

We will explain you how to use these features in this chapter.

### **Measure and set the wheel circumference**

When you use the speed kit, you must measure and set the wheel circumference. Press MODE from setup mode until you see the wheel circumference screen.



**Wheel circumference screen.** The wheel circumference is entered in millimetres and you need to measure this quite often to keep the system accurate. The best is to use a soft tape measure and do it every time you go out from the pit. It will have influence on the speed and the tire wear

counters. Adjust the circumference by using the **▼** and **▲** buttons.

## **Analyse your data**

You can learn a lot about your performance on the track just from viewing the data on the display of the Laptimer. However if you want the full benefit of the Laptimer you should export the data from the Laptimer to a Data Analyser or to a PC (via the Data Analyser). This will give you the possibility to print or store all data electronically, and to make further analysis of the data.

## DATA ANALYSER

The Unipro Data Analyser is the perfect companion for your Laptimer. It is the fastest way to getting data out of the Laptimer, with the possibility to print the data, or view them while the driver is on the track.

### **Transferring data from the Laptimer to the Data Analyser is easy**



1. Turn the Laptimer on.
2. Press **MODE** to change to pit mode
3. Press **MODE** again to change to PC mode
4. Press **FUNC** to enable the infrared communication
5. Press OK on the Data Analyser to turn it on
6. On the Analyser go the main menu with "Transfer" as the top point. Just move the cursor to "Transfer" and press the arrow to the right to start transferring the data



Now the communication is started and all the data from the Laptimer is transferred to the Data Analyser in a few seconds. The red LED to the right is blinking when the Laptimer is sending data.

After the data is transferred to the Data Analyser they can be viewed, stored, printed and transferred to a PC using the USB connector. It is possible to store data from at least 50 Laptimers before transferring them to a PC.