

DYNAMICTM

DXTM *Modular Mobility System*

DX Dolphin Remote (DX-Rem34) Installation Manual



Order/Part Number for this Manual : GBK60025 issue 5

Important Notes

1. Read this Manual carefully before installing or operating your DX control system.
2. Due to continuous product improvement Dynamic reserves the right to update this Manual. This Manual supersedes all previous issues which must not continue to be used.
3. Any attempt to gain access to or in any way abuse the electronic components and associated assemblies that make up the wheelchair control system renders the Manufacturer's Warranty void and the Manufacturer free from liability.

Contents

1	Introduction	1
2	Related Documentation	2
3	Features	3
4	Specifications	5
	Electrical	5
	Mechanical	5
	Environmental	6
5	Operation	7
	On/Off and Key Lock system	7
	Arming/Disarming the locking system	7
	Using the system without the lock	7
	Joystick OONAPU	7
	Drive Program Selection and Display	8
	Profile Selection	8
	Drive Program Display	8
	Drive Inhibit Display	8
	Remote Status Display	8
	System Status LED	8
	Lighting Control	9
	Actuator Control	9
	Battery Gauge Display	10
6	Installation and Testing	11
	Attention: If replacing existing Power Wheelchair Controller	11
	Compatibility with Power Wheelchairs	11
	DX Dolphin Mounting	12
	DX Dolphin Connection with the DX System	13
	Testing	14
	Powering Up Method	14
	Power Up Response	14
	DX Dolphin Check Sequence	14
7	Batteries and Charging	15
	Battery Type	15
	Battery Charging	15
	Battery Gauge	16
	Battery Saver	16

Battery Condition Warnings	17
Battery High warning condition	17
Battery Low warning condition	17
Low Capacity warning condition	18
8 Programming	19
Introduction	19
Default Programs	19
Auto Download	20
Programming Tools	21
Dynamic Wizard	21
HHP	22
Wizard High Volume Programming	22
Example	22
DX Dolphin Wizard Programming	24
Drive Program Parameters	24
Keypad and Speed Pot Parameters	28
Joystick Parameters	30
Actuator Parameters	32
Lighting Parameters	36
DX Dolphin HHP Programming	37
Initial Operation	37
Test Driving and Saving Changes	38
To View / Adjust Drive Programs	38
To Adjust Joystick Source	39
Reverse Joystick - Forward / Reverse	39
To Enable Technician Mode	40
Joystick Calibration	40
Combined Lighting Actuator Module (CLAM) Enable	41
Lighting Module (LM) Enable	42
9 Diagnostics and Fault Finding	43
Flash Code	43
Limp Mode	47
Wizard Diagnostics	48
To View Diagnostics	48
Status Report	48
To View Status Report	48
Chair Log	49
To View Chair Log	49
10 Product Disclaimer	52
11 Electromagnetic Compatibility (EMC)	53

12 Maintenance 54

13 Safety and Misuse Warnings 55

14 Warranty 57

15 Sales and Service Information 58

16 Appendix A : Abbreviations 59

17 Appendix B : Change Record 61

18 Anhang C : Deutschsprachige Warnhinweise 62

1 Introduction

The DX Dolphin Remote is a DX compatible remote supplied by Dynamic Controls Ltd. As well as driving, this DX Remote has switches for selecting up to five actuators, which can then be operated under joystick control. A battery gauge, side lights, indicator lights, hazard lights, magnetic key and horn are also supported. Up to five individual Drive Programs or profiles are available, and the currently selected program is displayed.

This DX Remote has two standard DXBUS connectors so that it may be connected to the DX System.

The DX Dolphin Remote and the associated DX Power Module are fully programmable to cater for a wide range of chair types and user needs. Correct installation and programming are essential to ensure optimum performance and safety.

This manual and others listed below must be read and understood. For more information contact Dynamic Controls Ltd or an agent as listed in section 14.

Example DX System

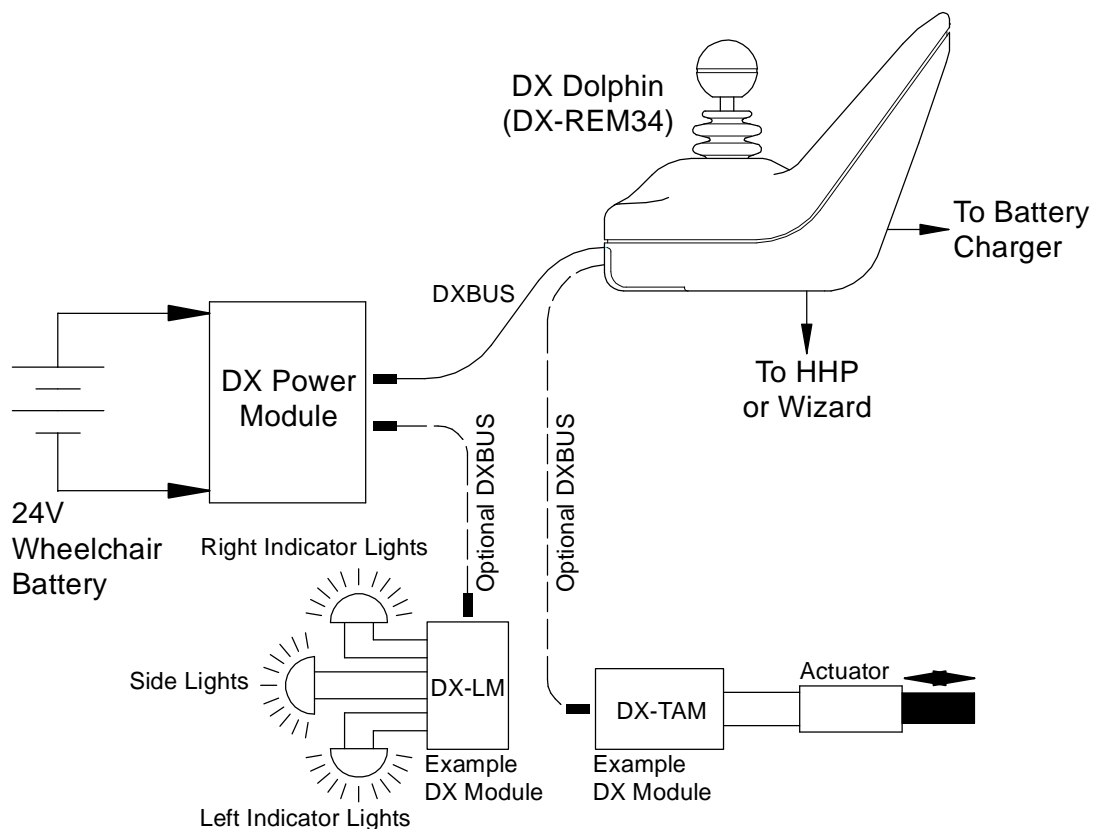

2 Related Documentation

A DX based wheelchair control system may comprise between two and sixteen DX compatible modules depending on the application. Each DX compatible module has its own Installation Manual which describes the installation requirements of that particular module.

This Manual describes installation of the DX Dolphin Remote only and must therefore be read in conjunction with the :

- DX Power Module (PMB) Installation Manual
- DX Hand Held Programmer (HHP) Manual
- Dynamic Wizard Installation Sheet / Online Help
- Installation Manuals for all other DX Modules to be used in your application.

3 Features

Joystick	Normally used for controlling wheelchair speed and direction. Can also be used for actuator control when any of the 5 actuators have been selected.
On/off switch /	Toggles the entire DX control system between the On and Off modes.
System Status LED	The System Status LED indicates the On/Off status of the system. It also flashes to indicate system faults. (Refer to Diagnostics section 9 for Fault Codes details.)
Remote Status LED	The Remote Status LED indicates the status of the Dolphin as an individual DX Module. If it is flashing, there is a fault within the Dolphin.
Battery gauge	Battery charge level is indicated by a set of ten LEDs. These are arranged in an arc from left to right as three red, four orange, and three green.
Actuator select switches (x5)	A separate switch for each set of seat raise/lower, seat tilt, back tilt, left leg rest and right leg rest, each with its own LED indicator. Once selected, actuator operation is activated using the joystick.
Drive Program select switch	A switch is used to cycle through and select one of the five Drive Programs.
Drive Program Display	A seven segment display for showing the currently selected Drive program.
Lighting controls	Separate push switches for the control of lights, indicators, and hazard, each with its own LED.
Horn switch	Activates horn while pressed if system power is on.
Magnetic key lock	Magnetic key may be used to "lock" the DX System to prevent unauthorised use (see later details).

Programming socket A standard HHP / Wizard socket.
HHP / Wizard socket

Standard DXBUS Connection (x2) For connecting the DX Remote, with a DXBUS cable for connection to other DX compatible modules.

Battery charger socket Standard 3 pin XLR type battery charger socket.

Fully functional keypad

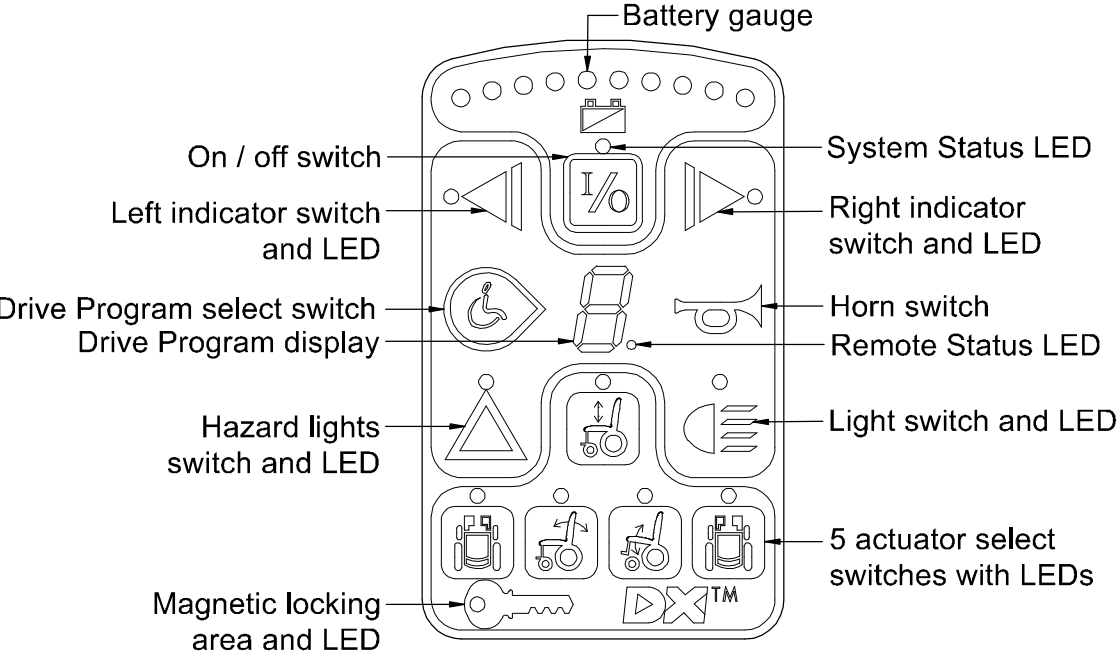

4 Specifications

Electrical

Compatible with standard DXBUS	
Operating voltage range	18V - 32 V d.c.
Charger rating	12 A RMS continuous, limited by DXBUS rating.
Quiescent Current	<1mA Off, typically 100mA On

Mechanical

Weight:	0.59 Kg
Mounting:	As per Installation section 6, Mounting
Case material:	Injection moulded plastic, Noryl N90 flame retardant

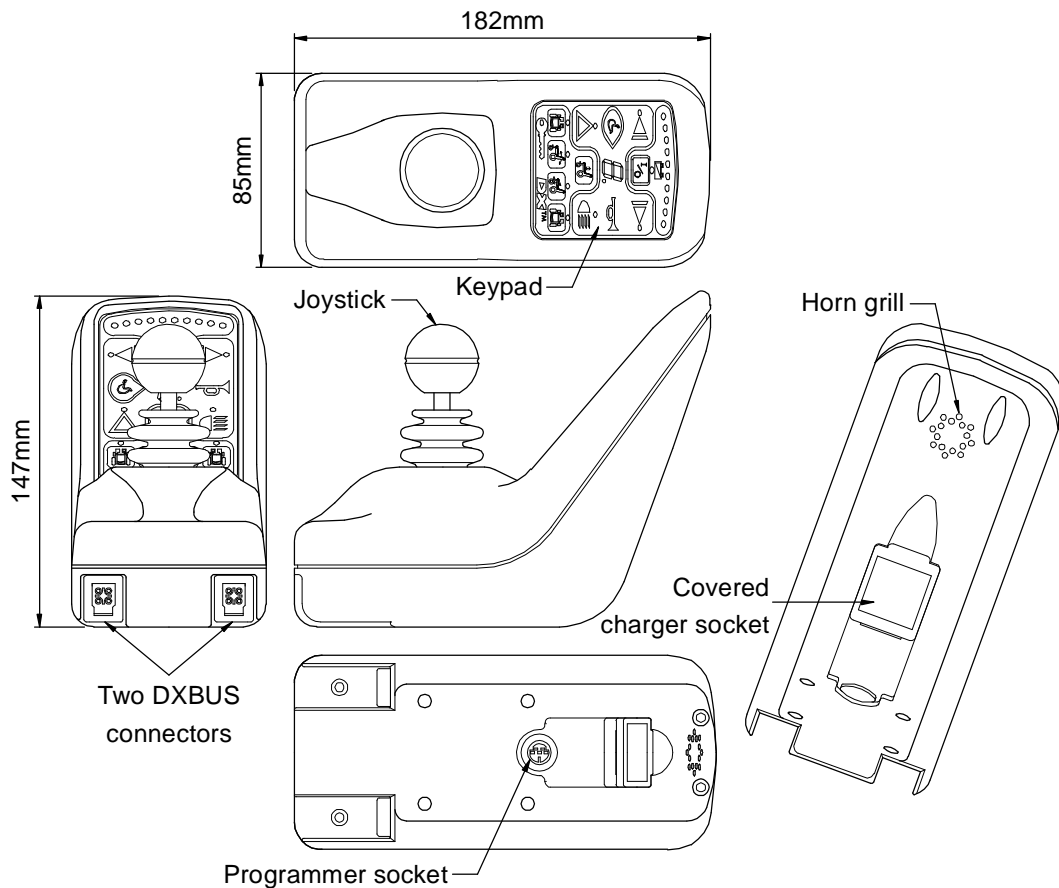

Environmental

Parameter	Min	Max	Units
Operating ambient temperature range	-25	50	°C
Storage temperature range	-25	70	°C
Operating and storage humidity	0	90	%RH
Environmental Rating	IP54		
RFI Emissions	CISPR 11, Class B.		
ESD	ISO7176 part 21		
Durability	ISO7176 part 14 (pending).		
Vibration Specification	BS2011: part 2Fd and BS7527: section 3.5, class 5M3.		

Complies with environmental standard : prEN12184.

5 Operation

On/Off and Key Lock system



The On/Off button toggles the system power on or off provided the DX Remote is not locked.



The Key Lock system uses a magnetic key to power the wheelchair down in such a way to prevent subsequent unauthorised power up and driving. This function is required for TÜV approval and operates as follows :

Arming/Disarming the locking system

To arm the locking system hold the magnetic key on or near the key symbol on the DX Remote front panel. The system will beep and automatically power itself down and no LEDs should be lit.

To turn the chair back on press the On/Off button. This will cause the system to power up but the chair needs to be disarmed before it can be driven - this waiting to be disarmed state is indicated by the flashing key symbol.

To disarm the lock put the magnetic key on or near the key symbol - this will cause the key to stop flashing and the chair may now be driven normally. If the wheelchair is not disarmed within one minute, the Dolphin will automatically turn itself off.

Using the system without the lock

If locking the chair is not required simply power the chair down by pressing the On/Off button - all indicators will go out.

To turn the system back on press the On/Off button - the system is now able to be driven without the use of the magnetic key.

Joystick OONAPU

All DX Remotes feature Out Of Neutral At Power Up (OONAPU) detection. If the system is powered up while the joystick is not in the neutral position, or an inhibit condition such as a battery charger is removed, the System Status LED flashes rapidly for either as long as the condition persists or for a maximum of 5 seconds.

If the condition persists, after 5 seconds a DX Module Fault (Flash Code 1) is signalled on the System Status LED, and the Remote Status LED flashes. This is a latching fault and must be cleared by powering the system down and up again (with the joystick in neutral).

An OONAPU fault is also generated if the joystick source is changed. This occurs when the Attendant / User switch on the DX-ACU is toggled or the Drive Program is changed causing a joystick swap, while the joystick is not in the neutral position. In these situations the fault is non-latching and the system does not need to be powered down to clear the fault.

Drive Program Selection and Display

The Dolphin can offer up to five different Driving Programs, depending on its configuration. (See Programming section.)

Profile Selection



Profiles can be selected using the Drive Program Select switch. Pressing this switch will increment the Drive Program number up to the maximum configured value. A further switch press will return the Dolphin to Profile 1.

Drive Program Display



The current Drive Program number is displayed on the 7-segment Drive Program Display. When the ACU has control of the wheelchair, this display is blank.

Drive Inhibit Display



A '-' is displayed on the Drive Program Display whenever the DX System is in Drive Inhibit state, e.g. during battery charging, operation of actuators, active Stop Switch (CLAM or TAM).

Remote Status Display



The Remote Module Status is displayed beside the 7-segment Drive Program display. This LED will flash if there is an internal DX Remote fault, or if an OONAPU fault has occurred.

System Status LED





The System Status LED is displayed above the On/Off switch. This LED is lit if the system is turned on. It also flashes in groups called Flash Codes, to indicate system faults.

Lighting Control

A set of four lighting control switches, with feedback LED's, are provided to control the Lighting System. A lighting module must be installed and enabled. Suitable modules include: DX Combined Lighting Actuator Module (CLAM); a DX Lighting Module (LM); or a DX Servo Lighting Module (SLM).

 The Light switch toggles on or off the Head/Tail/Sidelight output, independently of any other switch (except the On / Off switch). The Light switch LED is lit when the lights are activated.

 The Left or Right Indicator switch flashes the appropriate indicator output. These are turned off by either pressing the same Indicator switch again, or pressing the other Indicator switch, or the Hazard switch. Each associated LED is lit when its matching Indicator switch is active.





 The Hazard switch flashes both indicator outputs concurrently. The Hazard LED also flashes if the Hazard LED is enabled. (See Programming section.) The Hazard Indication can only be cancelled by pressing the Hazard switch again.

All lighting functions will only operate with the system power on. Refer to the relevant Installation Manual (e.g. LM or CLAM) for further lighting details.

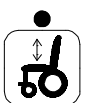
Actuator Control

 The DX Remote supports the control of up to five actuators if a correctly configured actuator control module is present (see Programming section). For example, a Combined Lighting Actuator Module (CLAM) can drive five actuators or a Two Actuator Module (TAM) can drive two actuators.



 The Dolphin has a set of five Actuator Select switches. Pressing an Actuator Select switch will inhibit driving and select the appropriate actuator output as indicated by the adjacent LED. The actuator order assigned in the Wizard as Actuator 1, 2, 3, 4 and 5 Enable, is arranged on the Dolphin keypad as follows:





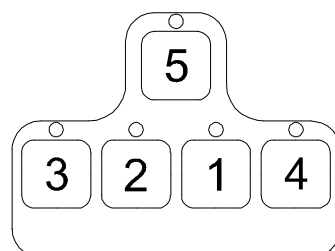

The actuator may then be adjusted up or down with the Joystick, by deflecting the Joystick beyond half travel in the forward / reverse axis.

To resume driving, press the current Actuator Select switch again to deselect. Alternatively another actuator may be selected directly.

If the user attempts to change modes (e.g. from driving to actuator mode) while the Joystick is deflected, the current mode will be terminated and the Joystick must be returned to neutral position before the newly selected mode will operate.

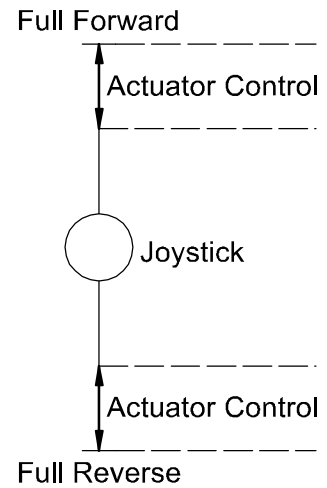

The Joystick Actuator parameter must be set to ‘yes’ and the Actuator While Drive parameter must be set to ‘no’ if actuators are to be controlled with the Dolphin Joystick, (See Programming section). An Actuator Remote Control (ARC) can be used to control the actuators. If an ARC is used to control the actuators the Actuator Select switches on the Dolphin are disabled and the Joystick Actuator parameter should be set to ‘no’.

The above information is for normal, intended operation of actuators by the Dolphin. Other options for actuator operation are possible, dependant on programming. See the TAM Installation Manual for full explanations.

Refer to the relevant DX Module Installation Manual for further actuator details.

Battery Gauge Display



Battery charge level is continuously indicated by a set of ten LED's. These are arranged in an arc from left to right as three red, four orange and three green.

The Battery Gauge provides true, useable battery capacity information, and indicates other related battery conditions. Full battery capacity is indicated by all ten LEDs on.

6 Installation and Testing

Attention: If replacing existing Power Wheelchair Controller

The model DX joystick/controller recently installed by your home care dealer, has been designed to function and perform in the same manner as the joystick/controller you may have already become accustomed to. If properly installed and programmed, you should notice no difference in the manner in which your wheelchair performs.

Should your wheelchair not perform as expected, or if you are not satisfied with its performance, immediately contact the home health care dealer who performed the installation, or contact Invacare Technical Services Department at (800) 333-6900.

Compatibility with Power Wheelchairs

The model DX Series power wheelchair controller will function on those wheelchairs equipped with the following specifications:

- Motor resistance from 0 to 0.5 ohms;
- Motor voltage from 20V to 30V;
- Batteries greater than 20Ahr lead acid;
- Motor current 60 - 80 Amp maximum;
- 12V or 24V parking brake;

(Note: 12V motors can be used if the controller is programmed to half speed)

Note : This controller is not designed for use with specialty type power wheelchairs, such as stair climbing wheelchairs or stand up wheelchairs.

DX Dolphin Mounting

The DX Dolphin Remote can be mounted on either side of the wheelchair, in an upright position, using four M4 screws.

Warning : For safe installation, select a screw length that protrudes between 4mm and 10mm into the case.

Dimensions of the mounting positions are shown below.

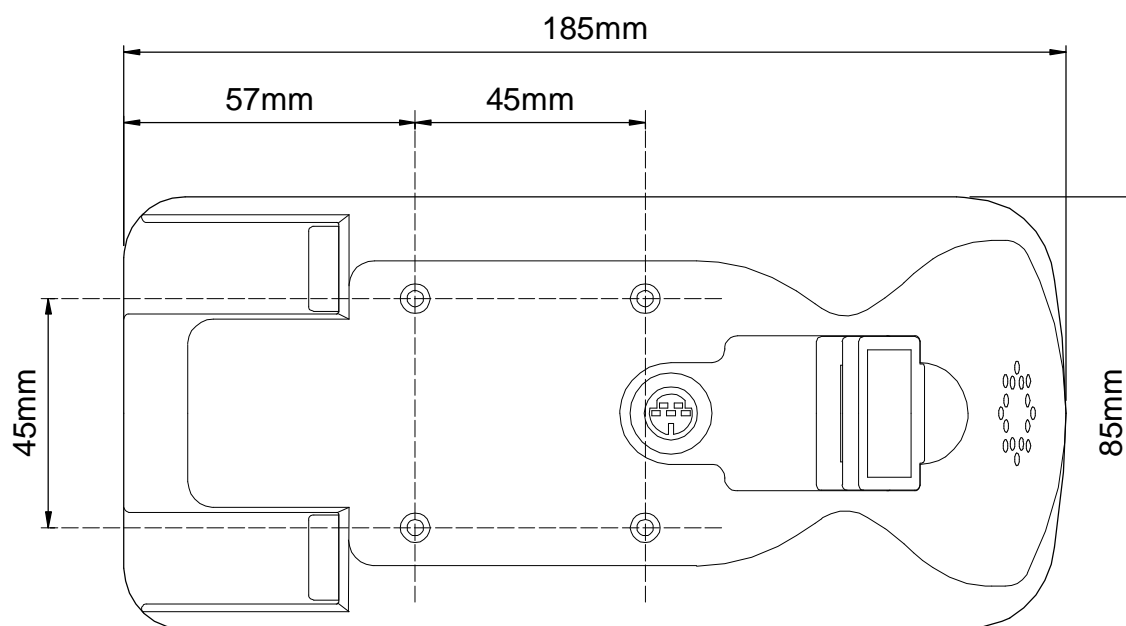

Note : If the programmer socket needs to be accessible when the DX Remote is mounted, make allowance for this prior to fitting.

DX Dolphin Connection with the DX System

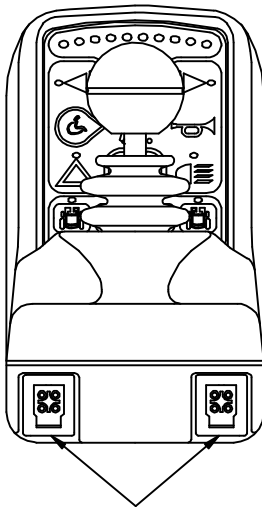

Two DXBUS
connectors

The Dolphin has two DXBUS connectors which enables any DXBUS cable to be used to interconnect it to the remainder of the DX system.

The Dolphin will normally be connected directly to one of the two PM DXBUS connectors.

Note : If only one DXBUS connector is used on the Dolphin and the remaining connector is accessible to the wheelchair user, a dummy connector should be fitted to the unused connector. This will comply with ISO7176.

The DXBUS cables are available in the following standard lengths:

DXBUS Cable, Straight, 0.12 M Part/Order Number GSM 630012

DXBUS Cable, Straight, 0.3 M Part/Order Number GSM 63003

DXBUS Cable, Straight, 0.5 M Part/Order Number GSM 63005

DXBUS Cable, Straight, 1.0 M Part/Order Number GSM 63010

DXBUS Cable, Straight, 1.5 M Part/Order Number GSM 63015

The DXBUS is also available with a ferrite.

DXBUS Cable, Ferrite, 2.0 M Part/Order Number GSM 63020F

Other cable lengths in multiples of 0.1 m are available on request.

Warning: Any protruding screws should be either plastic or plastic coated to prevent short circuits occurring with the DXBUS Cable pins.

Testing

Ensure that all DX Modules used in your DX System have been installed as specified in their Installation Manuals. The Dolphin needs to be correctly programmed for the appropriate wheelchair prior to testing.

A DX Remote contains the complete wheelchair system set up, from which all DX Modules download their relevant information when the DX System is first turned on. Refer to the later Auto Download section.

Powering Up Method

Power up the Dolphin by pressing the On/Off switch.

Power Up Response

The power up response for the Dolphin is :

- The System Status LED will come on steady.

Note : The first time the Dolphin is turned on, the System Status LED will flash a fault. This is because the Dolphin must download its information to the DX Power Module . Turn the Dolphin off then on to clear this fault. Refer to the later Auto Download section.

- At least one of the LEDs on the Battery gauge will be on.
- The Mode display will indicate a number from 1 - 5.

DX Dolphin Check Sequence

Perform the following Dolphin check sequence :

1. Press the On/Off switch again and check the Power LED turns off. Press it again to turn it on.
2. Press the Drive Program select switch a number of times. Check that the display changes as expected.
3. Check all Lighting Buttons operate correctly.
4. Check the Key Lock system operates correctly.
5. Perform the remainder of the tests as outlined in the Testing sections of the Installation Manuals of all other DX Modules used on the wheelchair.

7 Batteries and Charging

Battery Type

The DX System is designed to perform optimally with either Lead-Acid or Gel Cell 24 V deep cycle batteries, rated at 20 - 120 Amp hours. The maximum average discharge rate must not exceed half the rated capacity, in Amp hours.

High continuous discharge rates dramatically reduces the available battery capacity. For example, at a discharge rate equal to the rated capacity, the available capacity is 50 - 60 %. At a discharge rate of half the rated capacity, the available capacity is 70 - 80 %..

A wheelchair that draws maximum average battery current of 20 A, requires a battery of at least 40 Amp hours. A battery of only 20 Amp-hours, would begin to suffer a drop in performance at about half of its available capacity. The 40 Amp hour battery would have a full performance range of 4.5 times greater than the 20 Amp hour battery; a 80 Amp hour battery would only increase this range by 2.5 when compared to a 40 Amp hour battery.

Battery Charging

The battery charger socket is a 3 pin XLR type with pin configuration as shown below. Ensure that the charger used is compatible with this pin out before connection.

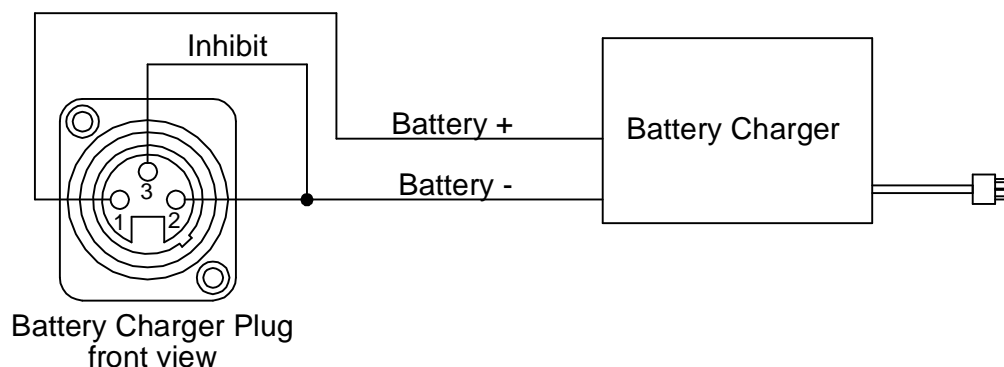

Note : The inhibit is shorted to B- on the Battery Charger plug.

The wheelchair is automatically disabled from driving whenever the battery charger is plugged in. The Drive Program will show  to indicate that the wheelchair is inhibited.

Connection of the battery charger will automatically power the wheelchair, if the wheelchair was powered down at the time of connection. This allows the progress of battery charging to be monitored on the Dolphin battery gauge. The wheelchair can, if required, be subsequently powered down by pressing the On/Off switch, and charging will still proceed normally.

Battery Gauge

The Battery Gauge provides true, useable battery capacity information. A full battery with at least 85 % of rated capacity, is represented by all ten LED's lit. Some new batteries can start with as little as 80 % capacity, developing higher capacity in their early life (sometimes up to 110 %), before slowly deteriorating over their rated life.

As the battery voltage drops, the number of LEDs lit reduces from right to left. When only the red LEDs are lit, the available battery capacity is typically less than 10 %. At this level and below, the Battery Gauge flashes at 1 Hz to alert the user that the wheelchair is running on reserve capacity. The battery capacity will reduce more rapidly in the reserve capacity range.

Battery Saver

The Battery Saver is a feature programmed into the DX Remote. When the battery capacity is in the reserve range (below 21V), the wheelchair performance is reduced. This is to preserve the life of the battery by encouraging the user to recharge the battery before it becomes harmfully flat.

Operating the wheelchair with more than two LEDs of the Battery Gauge lit will generally give normal wheelchair performance. This is provided that the battery size and the PM program settings are matched to the wheelchair.

Battery Condition Warnings

A battery warning is shown by the Battery Gauge flashing its LEDs, the number of which depends on what it currently has lit.

Battery High warning condition

This condition occurs when the battery voltage exceeds 28V, as measured by the PM.

The cause can be :

- The wheelchair is still on charge and the batteries are full or faulty.
- The batteries are overcharged.
- The wheelchair is travelling down a slope and the batteries are full or faulty.

The wheelchair will drive during this fault condition which will reset automatically when the battery voltage drops below 28V.

Battery Low warning condition

This condition occurs when the battery voltage drops below 23.3V, when the joystick is in neutral.

The cause can be :

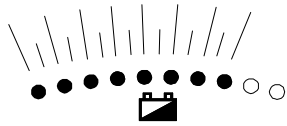

If the Battery Gauge flashes with orange or green LEDs lit, but the cause is not due to a Battery High warning condition, the battery or battery wiring may be faulty.

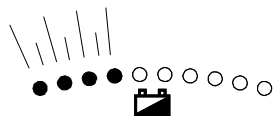

If the Battery Gauge flashes with just the left 3 or 4 LEDs after stopping the wheelchair, the battery may be too small for the wheelchair type, or the battery may be old or damaged.

The wheelchair will drive during this fault condition, but the flashing will continue until the joystick is returned to neutral again.

A Battery Low warning normally coincides with a Low Capacity warning.

Low Capacity warning condition

When the calculated available battery capacity drops below 10% of full capacity the two left most red LEDs flash.

The wheelchair will drive during this fault condition but it shows that the battery is in the reserve capacity range and battery capacity will begin to reduce rapidly. The Low Capacity warning will not stop until the batteries have been recharged adequately.

8 Programming

Warning !!

Incorrect or inappropriate programming of a DX System can put the wheelchair into a dangerous state. Dynamic Controls accept no responsibility or liability for accidents caused by incorrect programming. This Programming section, the HHP Manual, and the Dynamic Wizard Installation Sheet/Online Help must be read and understood before attempting to program a DX System.

Ensure that the programmed wheelchair complies with all prevailing regulatory requirements for your country and application.

Introduction

The driving performance of the DX System is dependant on its programming. Different features can be selected and parameters fine tuned for a particular application, or to suit the requirements of an individual.

The DX Remote and the DX Power Module are the modules most responsible for defining the driving performance of the DX System. Software in the DX Remote, processes the joystick movements according to its Drive Programs, and sends direction and speed commands to the PM.

Default Programs

The Dolphin is programmed during manufacturing with a set of factory default settings which are incorporated into a controlled document by Dynamic. The default settings programmed into a Dolphin will not be suitable for all DX Systems and must be checked and reprogrammed prior to connecting with a DX System.

The optimum settings for all programmable DX Modules are determined by the wheelchair manufacturer (OEM). If more than one type of wheelchair is to be used by the customer, each wheelchair type may have its own set of optimum settings.

Warning : If a wheelchair is programmed with settings other than default, under some very rare fault conditions default settings could be automatically restored, thereby changing driving characteristics. This in turn could lead to a chair moving in a direction or speed that is not intended. Programmers should consider this risk when programming settings other than default.

Auto Download

The DX System has a feature called Auto Download. It is designed to minimise the programming requirements associated with Module servicing by downloading the correct programming to a replacement DX Module.

A DX Module with a flashing System Status LED is considered faulty and, when serviced, is replaced by a new one. The replacement module is likely to be programmed differently to the one that it replaces, which could leave the wheelchair in a dangerous state. The DX System automatically detects that a DX Module swap has occurred, and the programmed data from the old module is transferred to the replacement module.

Auto Download is achieved by the DX Remote containing both its own programming and also a backup copy of the programmed data for all other DX Modules. When a module swap is detected, or a checksum error found in a module, the DX Remote automatically downloads its backup copy to the module. The Auto Download occurs immediately on power up after the Module has been replaced. This applies to all DX Modules **except** a DX Remote.

Warning : When a Dolphin is replaced it will perform an Auto Download to all DX Modules. This may result in incorrect and dangerous programming for a particular wheelchair system if the wheelchair program installed in the Dolphin is not suitable for that wheelchair system.

Do not attempt to drive or test the DX System before the correct and suitable wheelchair program has been installed in the Dolphin using the Wizard.

The Dolphin can be programmed with the Wizard using a 'dummy' DX System and / or a 24V power supply, or on the wheelchair provided driving is prevented e.g. by disengaging the drive wheels.

After replacing any DX Module, turn the DX System off, then on again, to initiate the Auto Download of the DX Remote backup data. When an Auto Download has occurred, but the system needs to be cycled on and off, a Module Fault (Flash Code 1) is displayed on the DX Remote's System Status LED and also the Status LED of the offending module. When the System is turned off then on again, the fault is cleared and the Auto Download is correctly terminated.

Programming Tools

Two programming tools are available, the Dynamic Wizard and the HHP.

Dynamic Wizard

The Wizard is a PC based tool suited to programming production runs of identical wheelchairs or modules, or individual highly customised wheelchairs. The Wizard is available in several versions :

OEM	Generally used by the wheelchair manufacturer. Able to program a wide range of parameters.
DEALER	Similar in function to above, but with a reduced range of programmable options. This ensures that options that the manufacturer wishes to keep control of cannot be disturbed. Parameters that may cause hazards or require special expertise to be set are not available to adjust.
ENHANCED DEALER	As above but with the ability to edit parameters that relate directly to wheelchair accessories (e.g. actuators).
FACTORY	Can only replace Standard or Custom Wheelchair Programs. No editing or diagnostics available.

Warning : The Wizard is a very powerful tool and as such requires well trained operators and a disciplined approach to usage and distribution.

It is up to the wheelchair manufacturer to determine whether they will allow distribution of the Wizard to dealers. Refer to the Wizard Documentation for further details.

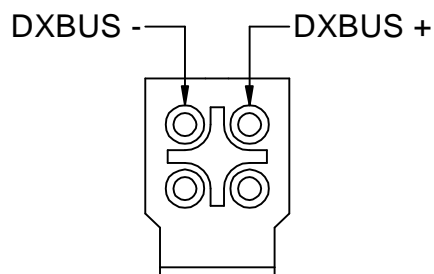

Dolphin DXBUS Pins

A Dolphin can be programmed with the Wizard using a 24V power supply and an optional PM. If the Dolphin is connected directly to the 24V power supply, then a DXBUS Cable can have one end modified to connect to the power supply.

HHP

The DX Hand Held Programmer (HHP) is the normal programming tool used by dealers, allowing easy adjustment of all commonly adjusted Drive Program parameters.

Warning : The DX HHP is for use **only** by wheelchair manufacturers, their authorised dealers and support personnel. It is **not** intended for use by the wheelchair user.

The DX HHP Manual should be read and understood before attempting to use it.

Wizard High Volume Programming.

Programming in the factory environment is normally done using the Wizard.

With the Wizard's Create a new Chair Program option, you can set up the standard parameters for the Dolphin and any other modules used for a particular wheelchair. This Chair Program is then saved to disk under a name such as "SuperChair, Deluxe, with lights" and can be down-loaded to a Dolphin at the push of a button.

Example

Modify/Edit the "SuperChair, Deluxe, with Lights" Chair Program as follows.

1. Enter the Wizard's Main Menu screen as described in the Wizard Installation Sheet.
2. Use the keyboard or the mouse, to select the File, Open menu option.
3. Select the "SuperChair, Deluxe" program from the dialog box.
4. Select the 'Edit Module Parameters' menu option.
6. Select 'UCM Remote' or the required group of parameters.
7. Scroll through the list of Dolphin parameters and adjust as necessary.

8. Press «Enter» to accept the changes, or «Esc» to exit without saving. Select the File, Save menu option. These values will then be part of the Standard Chair Program for the “SuperChair, Deluxe”

Down load the “SuperChair, Deluxe” to a Dolphin as follows.

1. Connect the Wizard serial communications cable to the Dolphin programmer socket and return to the main menu of the Wizard.
2. Use the keyboard or the mouse to select the File, Open menu option.
3. Select the “SuperChair, Deluxe” program from the dialog box.
4. Select the ‘Program Wheelchair’ option.
5. Choose if the Chair Program is to be down-loaded to the ‘Total System’ (to program a fully built up chair system) or just the ‘UCM Remote’ (to pre-program the Dolphin only).
6. Press «Enter» to write the Chair Program data.
7. Disconnect the Dolphin and repeat for as many Dolphins, or DX Systems, as required, by repeating steps 4 through 7.

DX Dolphin Wizard Programming

The Wizard accesses a set of parameters that are programmed to define the configuration desired by a wheelchair manufacturer.

Some parameters can be both read and written to (edited) by an OEM and a Dealer. Other parameters can only be read but not edited. Some parameters available to an OEM are not displayed by a dealer.

The DX System, with the Dolphin, supports up to five user selectable Drive Programs. The Drive Programs govern the performance of the wheelchair, as suitable for different environmental and user conditions. Drive Programs are also adjustable with the HHP.

Remaining parameters are related to other system functions and DX Modules which may, or may not, be included in your DX System. Parameters that may be accessed by the HHP are marked with an asterisk (*).

Drive Program Parameters

The five Drive Programs (or Profiles) can be set up as, for example, an Indoors program, an Outdoors program or a Sports program. These settings are originally factory set to the values defined in the Chair Program used by the Wizard during the down-loading process.

The values of the Drive Programs can be altered for a particular wheelchair user using an HHP if necessary (except Damping Point and Sleep Timeout).

Note: As all program settings are stored in the Dolphin, replacement of the Dolphin in the DX System may result in a change in Drive Program values that may be substantially and dangerously different from those of the Dolphin it replaced. The Wizard may be used to up-load and save the 'old' system settings for later reprogramming of the replacement Dolphin.

Program (Profile) 6 is a special program that is automatically selected when an Attendant Control Unit (ACU) is connected and in the Attendant mode. Note that Program 6 is **not** programmable using the HHP on standard Dolphins. When the ACU is disconnected, or it returns to the 'User Mode', the wheelchair automatically reverts to the Program that was selected prior the ACU becoming active (see ACU User Manual for more details).

The Wizard can be used to restrict the minimum and maximum limits for Drive Program parameters adjustable with an HHP.

Max Forward Speed * Range : 10 - 100% Default : 100
OEM Access: Read / Write
Dealer Access: Read / Write

Sets the maximum speed obtainable for maximum forward joystick deflection.

Forward Acceleration * Range : 10 - 70% Default : 40
OEM Access: Read / Write
Dealer Access: Read / Write

Sets the maximum output (linear) acceleration rate for large joystick forward deflections, where 70% provides the quickest response.

Warning : Setting the Acceleration / Deceleration too low or too high can result in an unsafe wheelchair. Test thoroughly after programming to ensure that the wheelchair complies with regulatory requirements such as ISO7176 7176 and the GMD-TND Homologation Directive R04 for maximum allowable braking distance.

Forward Deceleration * Range : 15 - 100% Default : 70
OEM Access: Read / Write
Dealer Access: Read / Write

Sets the maximum braking effect (linear deceleration) for large joystick deflection back towards neutral, where 100% provides maximum braking effect.

Max Reverse Speed * Range : 10 - 100% Default : 70
OEM Access: Read / Write
Dealer Access: Read / Write

Sets the maximum speed obtainable for maximum reverse joystick deflection.

Reverse Acceleration * Range : 10 - 70% Default : 40
 OEM Access: Read / Write
 Dealer Access: Read / Write

Sets the maximum output (linear) acceleration rate for large joystick backward deflections, where 70% provides the quickest response.

Reverse Deceleration * Range : 15 - 100% Default : 70
 OEM Access: Read / Write
 Dealer Access: Read / Write

Sets the maximum braking effect (linear deceleration) for large joystick deflection back towards neutral, where 100% provides maximum braking effect.

Max Turning Speed * Range : 10 - 100% Default : 50
 OEM Access: Read / Write
 Dealer Access: Read / Write

Sets the maximum turning speed obtainable for maximum joystick deflection left or right.

Turning Acceleration * Range : 10 - 70% Default : 40
 OEM Access: Read / Write
 Dealer Access: Read / Write

Sets the maximum output (linear) acceleration rate for large joystick left and right deflections, where 70% provides the quickest response.

Turning Deceleration * Range : 15 - 100% Default : 70
 OEM Access: Read / Write
 Dealer Access: Read / Write

Sets the maximum braking effect (linear deceleration) for large joystick deflection back towards neutral, where 100% provides maximum braking effect.

Damping Point * Range : 10 - 100% Default : 40
 OEM Access: Read / Write
 Dealer Access: Read / Write

The damping point defines the speed error size (of output speed verses joystick demand speed) using progressive error reduction (ie acceleration / deceleration). Speed errors exceeding this value will be limited to the programme maximum linear acceleration or deceleration rate. In other words it sets the 'compromise' ratio between joystick directness / responsiveness and chair controllability. Note: for most applications the default value of 40% should not require adjusting. Achieving the desired response is done by setting the appropriate acceleration / deceleration values.

Warning : An unsuitably high or low value can make the wheelchair unstable.

Joystick Source * State : Local / Remote Default : Local
 OEM Access: Read / Write
 Dealer Access: Read / Write

Selects whether the Drive Program will use the Dolphin's built in joystick or an external RJM based input control device.

Reverse J/S - Fwd/Rev State : Normal / Reverse Default : Normal
 OEM Access: Read / Write
 Dealer Access: Read only

Reverses the direction of the Dolphin's inbuilt joystick, This can be set for each profile.

If set to 'Normal', forward and reverse joystick deflection causes forward and reverse motion respectively.

If set to 'Reverse', forward and reverse joystick deflection causes the opposite effect. Used if the Dolphin was to be mounted in any other than standard orientation in order to maintain joystick sense.

Sleep Timeout Range : 1 - 255 min. (off) Default : 255 min (off)
OEM Access: Read / Write
Dealer Access: Read / Write

Inactivity timeout. The DX system goes to sleep after 'x' minutes of inactivity, if enabled.

Keypad and Speed Pot Parameters

Max Profile Number Range: 1 - 5 Default: 5
OEM Access: Read / Write
Dealer Access: Read only

Sets the number of Profiles (Drive Programs) available for selection by the user of the Dolphin. The Dolphin supports up to 5 user programs (profiles).

Wrap Profiles State: yes / no Default: yes
OEM Access: Read / Write
Dealer Access: Read only

Allows Profile 5 to wrap around to Profile 1 (and vice-versa).

Change Prof Driving State: yes / no Default: no
OEM Access: Read / Write
Dealer Access: Read only

If set to 'no', the Drive Program can only be changed while the wheelchair is stopped. If set to 'yes', the Drive program can be changed while driving.

Warning : Care should be taken if set to 'yes' if adjacent Drive Programs have markedly different settings (this includes the wrap-around between Prog 1 and Prog 5).

We recommend you do not set this parameter to 'yes' if the DX System contains an RJM based input device, as this would cause the wheelchair to come to a sudden halt when changing to an RJM Drive Program, or visa versa.

Allow Non Driv Prof State: yes / no Default: no
 OEM Access: Read / Write
 Dealer Access: Not available

If set to 'yes', Drive Program 0 is enabled and is displayed between Drive Profile 5 and Drive Profile 1.

Lock Enable State: yes / no Default: yes
 OEM Access: Read only
 Dealer Access: Read only

Enables the Dolphin's magnetic key operated lock function.

Speed Pot Scalar Range: 20 - 100% Default: 100
 OEM Access: Read / Write
 Dealer Access: Read only

The Dolphin does not have a speed potentiometer, do not change default. Sets the maximum forward and reverse speed scalar when speed pot is set at minimum.

Sleep Mode Enable State: disable / enable Default: disable
 OEM Access: Read / Write
 Dealer Access: Read / Write

Set to 'Enable' if Sleep Mode is required. System goes to sleep (partial power down) after [sleep timeout] minutes of inactivity. The system can be woken up by activating the last selected device or any switch on the Dolphin.

Joystick Parameters

Neutral Maximum Range: 10 - 49 Default: 10
 OEM Access: Read / Write
 Dealer Access: Read / Write

Determines the neutral window size. Affects all joysticks used in the system. Adjust only in special cases.

Neutral to PB Delay Range: 20 - 5000 msec Default: 100
 OEM Access: Read / Write
 Dealer Access: Read only

The delay between zero output speed and de-energising the Park Brake. It is dependant on the particular Park Brake mechanics and motor characteristics. It is set so as to minimise the jerk or roll back when parking on a slope. The jerk is also influenced by the Load Compensation setting in the Power Module.

Reverse UCM Joystick State: normal / reverse Default: normal
 OEM Access: Read / Write
 Dealer Access: Read only

Reverses the direction (left / right) of the Dolphin's inbuilt joystick.

If set to 'Normal', left and right joystick deflection causes a left and right turn, respectively.

If set to 'Reverse', left and right joystick deflection produces the opposite effect. Forward and reverse are not affected. Used if the Dolphin is mounted in an other than standard orientation in order to maintain normal joystick sense.

UCM Dual Decode State: single / dual Default: dual
 OEM Access: Read only
 Dealer Access: Not available

Set to 'dual' for six wire joysticks with mirror signals. Normally set to 'dual' for safety requirements (View only, not adjustable by OEM).

Reverse RJM Joystick State: normal / reverse Default: normal
 OEM Access: Read / Write
 Dealer Access: Read / Write

Reverses the direction (left / right) of the RJM joystick.

If set to 'Norm', left and right joystick deflection causes a left and right turn, respectively

If set to 'Yes', left and right joystick deflection produces the opposite effect. Forward and reverse are not affected. Used if the RJM is mounted in an other than standard orientation in order to maintain normal joystick sense.

RJM Dual Decode State: single / dual Default: dual
 OEM Access: Read only
 Dealer Access: Not available

Set to 'dual' if the RJM is connected and has a six wire joystick with mirror signals. Normally set to 'dual' for safety requirements. (View only, not adjustable by OEM).

Actuator Parameters

Refer to the Installation Manual for the DX Module driving the actuators, e.g. TAM, CLAM, ARC5.

CLAM Enable * State: yes / no Default: no
 OEM Access: Read / Write
 Dealer Access: Read / Write

Must be set to 'yes' for CLAM or TAM operation.

CLAM is critical State: yes / no Default: no
 OEM Access: Read / Write
 Dealer Access: Read only

If set to 'yes', a CLAM or TAM must be present in the system and operating normally. The loss or lack of communications between the CLAM (or TAM) and the Dolphin will cause the wheelchair to stop, and a Flash Code 1 to be displayed by the Remote.

If set to 'no', the wheelchair will drive normally with no CLAM (or TAM) attached. Providing that all CLAM (or TAM) parameters have been programmed, this is a useful factory setting. It allows a CLAM (or TAM) to be added later to wheelchair systems that do not have one fitted, without the HHP or Wizard.

CLAM Slowdown Range: 0 - 100% Default: 20
 OEM Access: Read / Write
 Dealer Access: Read only

Set to a required percentage of maximum wheelchair speed allowed when the slow input is active. For this facility to be used, the hardware of the wheelchair must be arranged as described in the Slow / Stop section in the Installation Manual of the DX Module driving the actuators, e.g. CLAM or TAM.

Actuator 1 Enable State: yes / no Default: no
 OEM Access: Read / Write
 Dealer Access: Read only

If set to 'Yes', Actuator 1 is enabled and can be selected by pressing the Actuator 1 select switch on the Dolphin or ARC (Actuator Remote Control) type module.

If set to 'no', there will be no response to the Dolphin Actuator switch. Actuator buttons can be disabled if there are less actuators fitted to the wheelchair than the number of actuator switches on the Remote.

Actuator 2 Enable State: yes / no Default: no
 to
 Actuator 5 Enable
 OEM Access: Read / Write
 Dealer Access: Read only

As described for Actuator 1 Enable. Refer to the Installation Manual for the DX Module driving the actuators, e.g. TAM, CLAM, ARC5.

Actuator 1 | Limit Range: 3 - 12 amps Default: 6
 to
 Actuator 5 | Limit
 OEM Access: Read / Write
 Dealer Access: Read only

Sets the current trip point for each actuator between the allowable range of 3 - 12 Amps. Refer to the Installation Manual of the Actuator Module for details.

Actuator Timeout Range: 1 - 120 sec. Default: 30
 OEM Access: Read / Write
 Dealer Access: Read only

Sets the maximum time a wheelchair user can continuously operate any actuator.

Actr Open Circ Test State: yes / no Default: no
 OEM Access: Read / Write
 Dealer Access: Not available

When set to 'Yes', an open circuit at the actuator output pins of the Actuator Module (e.g. TAM or CLAM), will cause a Flash Code 2 to be displayed (see Diagnostics section). The wheelchair will still drive.

ARC Enable State: yes / no Default: no
 OEM Access: Read / Write
 Dealer Access: Read / Write

Must be set to 'yes' for Actuator Remote Control (ARC) operation.

Set to 'no' for control of actuators by the switches on the Dolphin and joystick.

Joystick Actuator State: yes / no Default: yes
 OEM Access: Read / Write
 Dealer Access: Read / Write

Set to 'no' if switch operation of actuators is required. This is not recommended since the Dolphin has only one switch per actuator.

Set to 'yes' if joystick operation of actuators is required. The Actuator Select switch will now select the actuator, if fitted, but will not cause it to operate. If the wheelchair is driving when an actuator is selected, it will stop driving.

Num Actuator Button State: one / two Default: two
 OEM Access: Read / Write
 Dealer Access: Read / Write

When set to 'one', pressing an Actuator Select switch, or moving the joystick forward, will toggle between the actuator up / extend and actuator down / retract.

Can only be set to 'two' for the Dolphin if the Joystick Actuator parameter is set to 'yes'. In this case, the joystick forward is used for actuator up / extend, and joystick down for actuator down / retract.

Actr While Drive State: yes / no Default: no
 OEM Access: Read / Write
 Dealer Access: Read only

If set to 'No', the wheelchair will not drive while an actuator is being operated. If the wheelchair is driving, the actuator command will be ignored until the joystick returns to neutral.

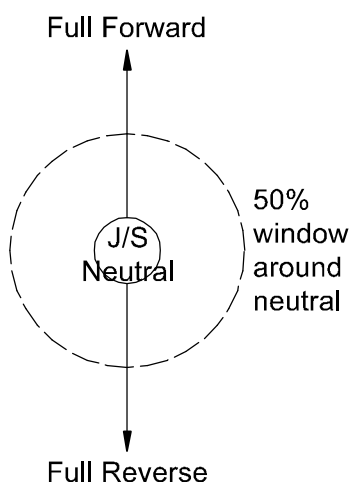

If set to 'yes' and the Joystick Actuator parameter is set to 'Yes', pressing the actuator button will stop the wheelchair from driving and select the actuator. The joystick can not be used to operate the actuator until it has returned to within the 50% window around neutral.

If the Joystick Actuator parameter is set to 'No', actuators can be operated irrespective of the driving state of the wheelchair.

Lighting Parameters

Lighting Mod Enable * State: yes / no Default: no
 OEM Access: Read / Write
 Dealer Access: Read / Write

Set to 'yes' for Lighting Module (LM) operation, 'no' if Combined Lighting Actuator (CLAM) based lights are used.

CLAM Lighting Enable * State: yes / no Default: no
 OEM Access: Read / Write
 Dealer Access: Read / Write

Set to 'yes' for CLAM operation, 'no' in all other cases.

Side Lights Enable State: yes / no Default: yes
 OEM Access: Read / Write
 Dealer Access: Read only

If set to 'yes', Side Lights, if fitted, can be operated by the Dolphin.

If set to 'no', there will be no response to the Dolphin Light switch.

Indicators Enable State: yes / no Default: yes
 OEM Access: Read / Write
 Dealer Access: Read only

If set to 'yes', Indicators, if fitted, can be operated by the Dolphin.

If set to 'no', there will be no response to the Dolphin Indicator switches.

Hazard Enable State: yes / no Default: yes
 OEM Access: Read / Write
 Dealer Access: Read only

If set to 'yes', Hazard Lights, if fitted, can be operated by the Dolphin.

If set to 'no', there will be no response to the Dolphin Hazard Light switch.

DX Dolphin HHP Programming

Warnings: Do not plug the HHP in while the vehicle is in motion. Plug in the HHP while the DX System is turned on. A setting is saved once the NEXT button is pressed. If the DX System is turned off during programming, the current parameter being modified will not be saved and DX System will retain the previous setting.

Initial Operation

1. Turn on the DX System and plug the HHP into the Programmer Socket on the Dolphin. The initial screen appears for two seconds.

DX HHP V1.x

If a fault has occurred, the fault screen appears.

SYSTEM FAULT
5
L parkbrake
EXIT

The number and message displayed represents the Flash Code. See the Diagnostics section for the list of faults that can be displayed.

Press EXIT to return to the main menu.

2. Then the main menu screen reads :

** MAIN MENU **
View or edit?
Program : 1 ?
NEXT YES

Pressing NEXT cycles through the Main Menu options. These are the Drive Programs and Technician Mode enable / disable.

Test Driving and Saving Changes

Changes can be test driven before being permanently saved as the DX System can be driven with the HHP plugged in. Even if the HHP is disconnected, the changes will remain current until the DX Remote is turned off. Once turned off, the settings will return to their original values.

Changes are saved when the NEXT button on the HHP is pressed. If the DX Remote is turned off before the HHP is returned to the main menu, all changes to the current parameter are lost.

To View / Adjust Drive Programs

Pressing EXIT at any point during the procedure will return you to the main menu.

1. Press NEXT in the main menu until the appropriate Drive Program is shown.

** MAIN MENU **	
View or edit	
Program : 1 ?	
NEXT	YES

2. Press YES to edit Drive Program.

3. The screen now reads :

TUNE PROG 1 RESPONSE			
Max forward speed			
25%			
EXIT	NEXT	UP	DOWN

Press NEXT to step through the adjustable parameters.

These are :

- Max. Forward Speed
- Forward Acceleration
- Forward Deceleration
- Max. Reverse Speed
- Reverse Acceleration
- Reverse Deceleration
- Max. Turning Speed
- Turning Acceleration
- Turning Deceleration

Damping Point
 Joystick Source
 Reverse Joystick - Fwd/Rev

Press UP or DOWN to adjust the value (excluding Joystick Source).

To Adjust Joystick Source

The Joystick Source screen reads :

TUNE PROG 1 RESPONSE		
Joystick Source		
Local		
EXIT	NEXT	SWAP

Pressing 'SWAP' toggles the parameter between :

'Remote' if an RJM based input device is fitted, and 'Local' if the joystick on the Dolphin is to be used.

This setting does not affect the ACU profile.

Reverse Joystick - Forward / Reverse

The Joystick Reverse screen reads :

TUNE PROG 1 RESPONSE		
Joystick reverse		
Normal		
	NEXT	SWAP

- Pressing 'SWAP' toggles the parameter between 'Normal' and 'Reverse'.

This parameter reverses the forward / reverse direction of the controlling joystick.

If set to 'Normal', forward and reverse joystick deflection causes forward and reverse motion respectively.

If set to 'Reverse', forward and reverse joystick deflection causes the opposite effect. Used if the Dolphin was to be mounted in any other than standard orientation in order to maintain joystick sense.

To Enable Technician Mode

1. In the main menu, press NEXT until the Technician Mode screen appears:

```

** MAIN MENU **
Technician Mode
disabled. Enable ?
NEXT          YES
  
```

Pressing YES toggles this screen between Technician Mode Enabled and Technician Mode Disabled. If disabled, press YES to enable.

2. Press YES and a password screen will appear.

```

Technician Mode
Enter Password
  0 0 0
EXIT   D1   D2   D3
  
```

3. Press the D1, D2 and D3 buttons to cycle each digit through to the correct password. When the password reads correctly, press the EXIT button.
4. The screen now reads :



```

** MAIN MENU **
Technician Mode
enabled. Disable ?
NEXT          YES
  
```

Joystick Calibration

1. Enable the Technician Mode
2. Press NEXT in the main menu until the screen reads :

```

** MAIN MENU **
View or edit Remote
Module ? (Tech Only)
NEXT          YES
  
```

Press YES.

- The display reads:

JOYSTICK CALIBRATION		
EXIT	NEXT	BEGIN

Pressing EXIT at any point during the calibration procedure will return you to screen  .

- Press BEGIN.

JOYSTICK CALIBRATION		
Rotate J/S		
-> Neutral -> END		
EXIT		END

- Move the joystick around the outer physical extremities of the restrictor plate. Ensure that all corners are pressed into.
Return the joystick to neutral.
- Press END to end the sequence and return to the main menu.
The calibration is saved.

Combined Lighting Actuator Module (CLAM) Enable

- Enable the Technician Mode
- Press NEXT in the main menu until the screen reads :

** MAIN MENU **	
View or edit Remote Module ? (Tech Only)	
NEXT	YES

Press YES.

- The display reads:

CLAM		
disabled. Enable ?		
EXIT	NEXT	YES

Pressing YES toggles between CLAM enabled and CLAM disabled. Setting this parameter to 'Enabled' allows the CLAM or TAM to be used in the DX System.

Pressing EXIT will return you to screen  .

Lighting Module (LM) Enable

1. Enable the Technician Mode
2. Press NEXT in the main menu until the screen reads :

<p>** MAIN MENU ** View or edit Remote Module ? (Tech Only) NEXT YES</p>
--

Press YES.

3. The display reads:

<p>LM disabled. Enable ? EXIT NEXT YES</p>
--

Pressing YES toggles between LM enabled and LM disabled. Setting this parameter to 'Enabled' allows the LM to be used in the DX System.

Pressing EXIT will return you to screen  .

9 Diagnostics and Fault Finding

DX Dolphin diagnostics can be examined from two platforms : from the Flash Codes signalled with the System Status LED on the Dolphin (and on the HHP); and from the Wizard which can provide more detailed information about the fault.

Flash Code

Any fault condition on the DX system will cause the Dolphin's System Status LED to flash. Flashing occurs in bursts of flashes separated by a two second pause. The number of flashes in each burst is referred to as the Flash Code and indicates the nature of the fault. The title of the Flash Code fault is also displayed by the HHP if connected to the faulty wheelchair.

Faults that affect the safety of the chair will cause the chair to stop while less critical ones will be indicated but allow the chair to continue driving. Some faults will automatically clear when the fault condition is removed, in which case the System Status LED will become steady and the wheelchair may be driven normally. Other faults are latched and must be cleared by turning the DX System off, waiting for two seconds, turning it back on again.

DX System Status LED Flash Code	Likely Cause of Condition and Possible Action
1	<p>DX Module Fault (see Limp Mode below)</p> <p>Cause: An Auto Download has occurred. Action < Turn the Dolphin off then on again.</p> <p>Cause: The Dolphin is not correctly programmed. Action < Try reprogramming the Dolphin.</p> <p>Cause: Connection between DX Modules may be faulty, or there may be an internal fault in a Module. Action < Check DXBUS connections and replace where necessary.</p> <ul style="list-style-type: none"> < If the Status LED on another Module is flashing, replace the Module. < An expected module may not be present (e.g. the DX Lighting Module).

DX System Status LED Flash Code	Likely Cause of Condition and Possible Action
2	<p>DX Accessory Fault Cause: There is a fault in an accessory device attached to a DX Module (excluding the PM). Examples of faults in accessory devices may be : the clutch is, or has been, disengaged; a light bulb is short or open circuit; an actuator terminal is shorted to Battery +. Action < Check all accessory devices connected to your DX System.</p>
3	<p>Left (M1) Motor Fault Cause: The connection from the PM left (M1) connector to its associated motor, or the motor itself, is defective. The connection is either open or short circuit. Action < Disconnect the left motor plug and check continuity between the motor pins on M1.</p>
4	<p>Right (M2) Motor Fault Cause: The connection from the PM right (M2) connector to its associated motor, or the motor itself, is defective. The connection is either open or short circuit. Action < Disconnect the right motor plug and check continuity between the motor pins on M2.</p>
5	<p>Left (M1) Park Brake Fault Cause: The M1 plug connection to its associated Park brake is either open or short circuit. Action < Disconnect the M1 plug and check continuity between the two Positronic park brake pins.</p>
6	<p>Right (M2) Park Brake Fault Cause: The M2. plug connection to its associated Park brake is either open or short circuit. Action < Disconnect the M2. plug and check continuity between the two Positronic park brake pins.</p>

DX System Status LED Flash Code	Likely Cause of Condition and Possible Action
7	<p>Low Battery Fault</p> <p>Cause: The battery charge is not sufficient to allow safe driving. It has fallen below 17V</p> <p>Action < Check battery connection and terminals. The battery voltage should be similar when the battery is on charge, and when it isn't.</p> <p>< Check that fuses have not blown, or circuit breakers tripped.</p> <p>< Replace battery if worn out or if capacity is insufficient for the user's needs.</p> <hr/> <p>Note: The wheelchair will behave sluggishly and the Battery Gauge will flash indicating low battery voltage prior to the display of this fault.</p>
8	<p>Overvoltage Fault</p> <p>Cause: The battery voltage has exceeded 32V.</p> <p>Action < If this fault occurs during battery charging, the battery charger is defective or incorrectly adjusted.</p> <p>< Check the battery chargers open circuit voltage is in accordance with the battery manufacturers limits, and is less than 32V.</p> <p>Cause: The battery connector is making intermittent contact when the wheelchair is stopped, or travelling down a slope.</p> <p>Action < Check that the battery wiring and terminating is secure.</p>
9	<p>CANL Fault (see Limp Mode below)</p> <p>Cause: 1. An invalid voltage has been detected on the DXBUS CANL line.</p> <p>2. Communication is not possible using the CANL wire.</p> <p>Action < Check the continuity of the DXBUS cable.</p> <p>< Check for shorts between DXBUS pins. An open or short circuit on another DX Module can cause this fault.</p>

DX System Status LED Flash Code	Likely Cause of Condition and Possible Action
10	<p>CANH Fault (see Limp Mode below)</p> <p>Cause: 1. An invalid voltage has been detected on the DXBUS CANH line.</p> <p>2. Communication is not possible using the CANH wire, or the CANH and CANL wires are shorted together.</p> <p>3. Hazard lights were turned on when the DX System was turned on.</p> <p>4. The CANH is used to generate a Kill signal by any DX Module which detects an unsafe condition, or by an external device such as an emergency stop switch.</p> <p>The CANH wire is pulled to either Battery + or Battery - and causes the DX System to shut down.</p> <p>Action < Check the continuity of the DXBUS cable.</p> <p>< Check for shorts between DXBUS pins. An open or short circuit on another DX Module can cause this fault.</p> <p>< If the Hazard Lights were already switched on when the DX System was turned on, Flash Code 10 and Limp Mode (slow driving) may result.</p> <p>To clear this fault, turn the Hazard Lights off, then turn the DX System off then on again.</p> <p>< If generated by a Kill signal, the cause of the fault is severe.</p>
11	<p>Stall Timeout Fault</p> <p>Cause: The motor current has been at, or close to, current limit for longer than the Stall Timeout parameter value.</p> <p>Action < Turn the DX System off then on again.</p>

DX System Status LED Flash Code	Likely Cause of Condition and Possible Action
12	<p>Module Mismatch</p> <p>Cause: There is a compatibility problem between DX Modules in the System. The wheelchair will be disabled.</p> <p>Action < Consult your Dynamic Service Centre.</p> <p>Cause: The data held by the Dolphin for another DX Module is corrupt or incompatible with that module.</p> <p>Action < Reprogramming the wheelchair system may correct this problem.</p>

Limp Mode

If the DX System detects some faults, it will revert to Limp Mode. This is a reduced speed mode which recognises problems, but allows the wheelchair user to limp home, where the problem can be assessed.

Wizard Diagnostics

The Programming Configuration Diagnostic (known as the Wizard) tool is used to provide diagnostics for the Dolphin.

To View Diagnostics

1. Enter the Wizard's Main Menu screen as described in the Wizard Installation Sheet / Online Help.
2. Select the 'Diagnostics' menu.

The menu displays the following options:

Status Report
Print Status Report
Chair Log
Print Chair Log
Erase Chair Log

Print Chair Log prints the Status Report followed by the Chair Log. These reports should be sent along with a faulty controller to a Service Centre. contact a Dynamic Sales and Service Centre (refer to section 14).

Status Report

The Status report gives you the current status of the wheelchair, including faults and other warning conditions currently active. Pressing «?» Or selecting 'Info' will display further information about the condition. Some conditions in the Status Report are not caused by actual faults, but are only temporary conditions e.g. a motor lead was not connected when the DX System was turned on and driving was attempted, producing a Motor Fault.

To View Status Report

1. Perform steps 1. and 2. above.
2. Select 'Status Report'.
3. From the 'Modules Attached' menu, select 'UCM Remote'.

Chair Log

The Chair Log displays all faults and warning conditions recorded for the wheelchair since the Chair Log was last erased. Some conditions logged in the Fault History are not caused by actual faults, but are only temporary conditions e.g. a motor lead was not connected when the DX System was turned on and driving was attempted, producing a Motor Fault. It is recommended to erase the Chair Log once the system is fully functional as only the previous 15 fault conditions are recorded.

To View Chair Log

1. Enter the Wizard's Main Menu screen as described in the Wizard Installation Sheet / Online Help.
2. Select the 'Diagnostics' menu.
3. Select 'Chair Log'.
4. From the 'Modules Attached' menu, select 'UCM Remote'.

Below are listed the Chair Log codes and probable causes of these faults. If the suggested action does not remove the fault, contact a Dynamic Sales and Service Centre (refer to section 14).

Message	Probable Cause and Action
CPU / General Fault	Cause : Internal Fault Action: < Replace Dolphin. < Consult an approved Dynamic Service Agent.
ADC Fault	Cause: Internal Fault Action: < Replace Dolphin. < Consult an approved Dynamic Service Agent.

Message	Fault and Possible Cause
CAN short fault	<p>Cause : 1. Short between CANL and CANH.</p> <p>Action: < The short may be within a module or within a DX Cable, or the exposed DXBUS contacts may be shorted by foreign material. Ensure that all DXBUS contacts are clean.</p> <hr/> <p>Warning : Open circuit breaker or disconnect from PM before probing around DXBUS connectors.</p> <hr/> <p>Disconnect any optional modules and turn on the Dolphin. Use the Wizard Status Report to check if the CAN shorted fault is still present. If possible, substitute the DXBUS Cable between the Dolphin and the PM. Disconnect any unnecessary DXBUS Cables. When the fault no longer occurs, add cables and modules one by one until the faulty cable or module is identified. Replace the faulty part. If the fault remains, try replacing the Dolphin and the PM.</p> <p>If the fault cannot be reproduced, check all cables and DX connectors for foreign material or damage.</p>
CAN L fault	<p>Cause: CANL failure.</p> <p>Action < Check for a short from CANH to another DXBUS wire, or a short from CANL to DXBUS- or DXBUS+.</p>
Wake-up Fault	<p>Cause : Incorrect voltage on CANH.</p> <p>Action < Check for a short from CANH to another DXBUS wire, or a short from CANL to DXBUS- or DXBUS+.</p> <p>< Check battery wire terminations.</p>
JS OONAPU occurrence	<p>Cause : 1. The joystick was Out Of Neutral At Power Up. This is a fault condition produced if the DX System is turned on while the joystick is not in the neutral or non-driving position.</p> <p>Action < Allow the joystick to return to neutral and turn the DX System off then on again.</p>

Power button open circuit	<p>Cause : The Dolphin On/Off switch may be shorted or open circuit.</p> <p>Action < Turn the Dolphin off then on again.</p>
Power button stuck	<p>Cause : The Dolphin On/Off switch may have been held down too long, appears to be shorted or a wire to the power button is broken.</p> <p>Action < Check for broken wires or faulty connections. < Turn the Dolphin off then on again.</p>
Joystick Mirror fault	<p>Cause : Joystick internal error.</p> <p>Action < Replace joystick. < Consult an approved Dynamic Service Agent.</p>
Joystick Absolute Error Fault	<p>Cause : Joystick internal error.</p> <p>Action < Replace joystick. < Consult an approved Dynamic Service Agent.</p>
Joystick fault	<p>Cause : 1. The joystick may need to be re-calibrated.</p> <p>Action < Consult an approved Dynamic Service Agent.</p>

10 Product Disclaimer

Dynamic Controls Ltd. products built today allow our customer's vehicles to conform to national and international requirements.

In particular to: **ISO7176-9** Climatic Tests for Electric Wheelchairs.
ISO7176-14 Power and Control Systems for Electric Wheelchairs.
ISO7176-21 Requirements and test Methods for Electromagnetic Compatibility of Electric Powered Wheelchairs and Scooters.

However the performance of controllers fitted to wheelchairs and scooters is very dependant on the design of the scooter or wheelchair so final compliance must be obtained by the vehicle manufacturer for their particular vehicle. No component compliance certificate issued by Dynamic Controls Ltd. relieves a wheelchair / scooter manufacturer from compliance testing their particular vehicles.

If Dynamic Controls Ltd. controllers are fitted to vehicles or applications other than wheelchairs and scooters, testing to appropriate standards for the particular application must be completed as ISO7176 may be inappropriate.

11 Electromagnetic Compatibility (EMC)

Dynamic Electronic Controllers have been tested on typical vehicles to confirm compliance with the following appropriate EMC standards:

Emissions:	CISPR22, class B
Susceptibility:	IEC1000-4-3
ESD:	IEC1000-4-2
Compliance levels and set-up as per ISO 7176, part 21.	

National and international directives require confirmation of compliance on particular vehicles. Since EMC is dependant on a particular installation, each variation must be tested. The guidelines in this section are written to assist with meeting EMC requirements.

Minimising Emissions

Motors : Motor brushes generate electromagnetic emissions. It may be necessary to fit capacitors between the brush holders and motor case. Ensure the leads are kept as short as possible.
A suitable capacitor is 4n7, 250V Ceramic.

Wiring : Keep wire lengths as short as practical for a tidy layout.
Minimise any wire loops, particularly loops of single wires as opposed to wire pairs.
Endeavour to run wires in pairs or bunches.
Where practical, tie cables to wheelchair frame.

Immunity to Radiated Fields

Follow the wiring recommendations for minimising emissions.

Immunity to ESD

Follow the wiring recommendations for minimising emissions.
Ensure all vehicle sub-frames are electrically connected.
Ensure speed setting potentiometers are electrically connected to the vehicle frame.
Do not leave connections unnecessarily exposed.

12 Maintenance

1. The DX System should be regularly checked for integrity. Loose, damaged or corroded connectors or terminals, or damaged cabling should be replaced.
2. All switchable functions on the DX System should be regularly tested to ensure they function correctly.
3. All DX system components should be kept free of dust, dirt and liquids. If necessary wipe with a cloth dampened with warm water or alcohol. **Do not** use solvents or abrasive cleaners.
4. Where any doubt exists, consult your nearest Service Centre or Agent.
5. There are no user-serviceable parts in any DX System component - do not attempt to open any case.

Warning If any DX component is damaged in any way, or if internal damage may have occurred (for example by being dropped), have it checked by qualified personnel before operating.

13 Safety and Misuse Warnings

Do not install, maintain or operate this equipment without reading, understanding and following the proper instructions and manuals, otherwise injury or damage may result.

The completed installation must be thoroughly checked, and all programmable options must be correctly adjusted for safe operation prior to use.

A warning must be conveyed to the wheelchair operator that the controller could cause the chair to come to a sudden stop. In situations where this may affect the safety of the user, this will require the fitting and wearing of a seat belt.

Performance adjustments should only be made by professionals of the health care field or persons fully conversant with this process and the driver's capabilities. Incorrect settings could cause injury to the driver, bystanders, damage to the chair and surrounding property.

After the wheelchair has been set up, check to make sure that the wheelchair performs to the specifications entered in the programming procedure. If the wheelchair does not perform to specifications, turn the wheelchair off immediately and re-program. Repeat procedure until the wheelchair performs to specifications.

Do not operate the DX System if it behaves erratically, or shows abnormal response, heating, smoke or arcing. Turn the system off, disconnect the battery or open the battery overload switch, and consult your Service Agent.

Do not operate your DX System if the battery is nearly flat as a dangerous situation may result due to loss of power in an inopportune place.

Ensure the controller is turned off when not in use.

No connector pins should be touched, as contamination or damage due to electrostatic discharge may result. Dummy sockets in unused DXBUS connectors should be left in place unless a new module is added to the system.

Most electronic equipment is influenced by Radio Frequency Interference (RFI). Caution should be exercised with regard to the use of portable communications equipment in the area around such equipment. While the manufacturer has made every effort to ensure that RFI does not cause problems, very strong signals could still cause a problem. If RFI causes erratic behaviour, shut the wheelchair off immediately. Leave off while transmission is in progress.

In the event of a fault indicator flashing while driving (battery gauge and / or status LED), the user must ensure that the system is behaving normally. If not, the system must be turned off and a Service Agent called immediately.

Report any malfunctions immediately to your Service Agent.

14 Warranty

All equipment supplied by Dynamic Controls Ltd is warranted by the company to be free from faulty materials or workmanship. If any defect is found within the warranty period, the company will repair the equipment, or at its discretion, replace the equipment without charge for materials and labour.

The Warranty is subject to the provisions that the equipment:

- Has been correctly installed.
- Has been used solely in accordance with this manual.
- Has been properly connected to a suitable power supply in accordance with this manual.
- Has not been subjected to misuse or accident, or been modified or repaired by any person other than someone authorised by Dynamic Controls Ltd.
- Has been used solely for the driving of electrically powered wheelchairs in accordance with the wheelchair manufacturer's recommendations.

15 Sales and Service Information

For Sales and Service advice, or in case of any difficulty, please contact:

Head Office

Dynamic Controls Limited
Print Place
Christchurch
New Zealand



Telephone: Int. 64 3 338 0016
Fax: Int. 64 3 338 3283

Australia

Electronic Mobile Service (EMS)
46 Berripa Close
North Ryde, Sydney
NSW Australia 2113



Tel 24 hr: Int. 61 2 9887 2824
Pager: Int. 61 2 9963 1778
Fax: Int. 61 2 9887 2114

North America

Rosstron Inc
1521 W. 259th St
Harbor City, CA 90710
USA



Telephone: Int. 1 310 539 6293
Fax: Int. 1 310 539 4078

Europe

Controls Dynamic Ltd
Lisle Avenue
Kidderminster
DY11 7DL.
United Kingdom



Telephone: Int. 44 1562 820 055
Fax: Int. 44 1562 742 720

Note: The controller should be clearly labelled with the manufacturer's service agent's telephone number.

16 Appendix A : Abbreviations

Abbrv.	Expansion / Explanation
ACU	Attendant Control Unit. A DX Module containing a joystick that is used by someone other than the person in the wheelchair to control the wheelchair.
ARC	Actuator Remote Control. A DX Module consisting of switches to control up to five actuators.
CAN	Controller Area Network
CANH	Controller Area Network High line. One of the four wires which make up the DXBUS.
CANL	Controller Area Network Low line. One of the four wires that make up the DXBUS.
CLAM	Combined Lighting and Actuator Module. A DX Module with five actuator and three lighting outputs.
DX	Dynamic Control Modular Mobility System
DXBUS	The DX System communication CAN communication lines plus power supply to DX Modules.
ESD	Electrostatic Discharge
HHP	Hand Held Programmer. The HHP can be used by both DX System and all DLxxUxxx Controllers.
ISO	International Standards Organisation
LED	Light Emitting Diode
LM	DX Lighting Module. A DX Module with lighting outputs.
OEM	Original Equipment Manufacturer. Generally refers to the wheelchair manufacturer.

OONAPU	Out Of Neutral At Power Up. A fault condition produced if the DX System is turned on while the joystick is not in the neutral (non-driving) position.
PM	DX Power Module. The DX Module that produces the DX System output to the motors and park brakes.
RFI	Radio Frequency Interference.
RJM	Remote Joystick Module. A DX Module that contains a joystick only, and can be used to control the wheelchair instead of the DX Remote used in the DX System.
TAM	Two Actuator Module. A DX Module with two actuator outputs.
TÜV	A German Safety Standards Authority.
UCM	User Control Module. The core component of all DX Remotes. The name is sometime used interchangeably with DX Remote.
Wizard	A Programming Configuration Diagnostics tool used by the DX System.

17 Appendix B : Change Record

This section lists the changes implemented into this manual from previous revisions.

Page / Section	Change	Approval
Page 2	Reference to 'PM' changed to 'PMB'	
Page 6	EMI note replaced by sections 10 & 11	PCO 2766
Page 19	Default Programs warning added.	PCO 2786
Page 47	Limp Mode examples removed.	
Section 10	Product Disclaimer Section added	PCO 2766
Section 11	Electromagnetic Compatibility Section added	PCO 2766
Section 13	Safety and Misuse Warnings rewritten	PCO 2766
Section 14	Warranty period rewritten	
Section 15	Contact numbers changed for EMS	PCO 2754
Section 17	Change Record section added	
Section 18	Contact numbers changed for EMS	PCO 2754

18 Anhang C: Deutschsprachige Warnhinweise

Der folgende Text muß in jedem Benutzerhandbuch erscheinen, welches dieses DX-Modul verwendet.

Installations-Hinweise für die DX-Handbedienung, Type 1.

Der folgende Text muß in jedem Bedienungshandbuch abgedruckt werden, welches die DX Handbedienung verwendet.

Das DX Installations-Handbuch ist ausschließlich für Rollstuhlhersteller geschrieben worden. Sofern der Rollstuhlhersteller ein Bedienungshandbuch zur Verfügung stellt, wird empfohlen zumindest die folgenden Auszüge an passender Stelle mit in das Handbuch einzufügen. Die folgenden Auszüge sind nicht geordnet und können je nach Zusammenhang in ein Handbuch eingefügt werden.

Einleitung

Der Batterielade-Zustand wird dauernd an dem Batterieanzeiger angezeigt. Wenn die vorletzte Stufe erreicht wird fängt der Anzeiger an zu blinken und zeigt dem Fahrer damit an, daß die Batterien unverzüglich geladen werden sollten. Die Steuereinheit arbeitet von dann an in einem 'Sparzustand' um die verbleibende Batteriekapazität optimal auszunutzen - der Rollstuhl reagiert dann langsamer und die Geschwindigkeit wird beschränkt.

Falls die Batterien soweit entladen werden, daß die Steuereinheit den Rollstuhl nicht mehr sicher manövrieren kann, dann hält der Rollstuhl an und die 'POWER' Leuchtdiode zeigt die Störung 'Batterie-Entladung' (7 Blinkzeichen, siehe Paragraph 8).

Wartungshinweise für die DX-Steuereinheit

- a) Alle Anschlüsse zum DX-Steuersystem sollten regelmäßig auf ihre Vollständigkeit hin überprüft werden. Lose, beschädigte oder korrodierte Buchsen und Stecker sowie beschädigte Kabel sollten ausgetauscht werden.

- b) Alle Schaltstellungen des DX-Steuersystems sollten regelmäßig überprüft werden, um dessen vollständige Arbeitsweise zu gewährleisten.
- c) Alle Teile der DX-Steuereinheit sollten von Staub, Schmutz und Flüssigkeiten freigehalten werden. Benutzen Sie bitte ein feuchtes Tuch mit warmem Wasser oder Alkohol sofern erforderlich. Benutzen Sie auf keinen Fall Lösungsmittel.
- d) Sollten irgendwelche Zweifel an der einwandfreien Arbeitsweise der Steuereinheit haben, dann lassen Sie die Steuereinheit bitte von einem Vertragshändler überprüfen bevor Sie sie wieder benutzen.
- e) Das DX System beinhaltet keinerlei wartungsbedürftige Teile für den Anwender, versuchen Sie daher nicht das Gehäuse zu öffnen.

Vorsicht: Wenn irgendwelche Komponenten der DX Steuereinheit beschädigt sind oder wenn Verdacht auf innere Beschädigung besteht (zum Beispiel nach äusserer Gewalteinwirkung), dann lassen Sie die Steuereinheit bitte von einem Vertragshändler überprüfen bevor Sie sie wieder benutzen.

Achtung: Jedweder Versuch, sich Zugang zu den elektronischen Teilen oder Komponenten des Rollstuhl-Steuersystems zu verschaffen, oder der Versuch diese zu mißbrauchen, macht die Garantie des Herstellers ungültig und befreit den Hersteller von jeglicher Haftung.

- f) Die Steuereinheit sollte mit einem deutlichen Hinweis auf die Adresse und Rufnummer des Vertragshändlers versehen sein.

Sicherheitsvorschriften

- a) Alle programmierbaren Werte müssen sorgfältig für eine sichere Bedienung eingestellt werden bevor das Gerät benutzt wird.

- b) Aus Sicherheitsgründen kann die Steuereinheit den Rollstuhl unvorhergesehen zum Stillstand bringen. Sollte dies die Sicherheit des Fahrers/Fahrerin beeinträchtigen, dann wird das Anbringen und Tragen von Sicherheitsgurten empfohlen.
- c) Die DX Steuereinheit ist voll programmierbar um optimale Leistung und Sicherheit zu gewährleisten. Bitte bedienen Sie den Rollstuhl nur dann, wenn Sie das Fahrzeug in voller Gewalt haben. Bitte sorgen Sie dafür, daß der Rollstuhl entsprechend Ihrer Wünsche und Ihrer Umgebung programmiert ist. Bitte wenden Sie sich an Ihren Vertragshändler sollten Veränderungen notwendig werden. Bitte wählen Sie ein sicheres Fahrprogramm aus, welches Ihrer Umgebung gut angepaßt ist.
- d) Bedienen Sie die DX Steuereinheit auf keinen Fall, wenn diese sich ungewöhnlich verhält oder wenn sich starke Hitze, Qualm oder Funken bilden. Bitte schalten Sie dann das System sofort ab, und treten Sie mit Ihrem Vertragshändler in Verbindung.
- e) Bedienen Sie die DX Steuereinheit nicht, wenn die Batterie fast leer ist. Dies könnte sich, aufgrund von Leistungsverlust an ungewünschtem Ort, in eine gefährliche Situation entwickeln.
- f) Bitte sorgen Sie dafür, daß die Steuereinheit abgeschaltet ist, wenn sie nicht benutzt wird.
- g) Bitte berühren Sie keine Kontakte der Steuereinheit weil dies zu Beschädigung der Elektronik führen könnte.
- h) Bitte benachrichtigen Sie Ihren Vertragshändler umgehend von jedwedigen Störungen.

Vertragshändler

Eine der folgenden Kontaktadressen muß in einem Bedienungshandbuch abgedruckt werden.

Mit Schwierigkeiten oder Fragen bezüglich Ihres DX wenden Sie sich bitte an:

Hauptgeschäftsstelle

Dynamic Controls Limited
Print Place
PO Box 1866
Christchurch
Neuseeland



Telephone: Int. 64 3 338 0016
Fax: Int. 64 3 338 3283

Australia

Electronic Mobile Service (EMS)
46 Berripa Close
North Ryde, Sydney
NSW Australia 2113



Tel 24 hr: Int. 61 2 9887 2824
Pager: Int. 61 2 9963 1778
Fax: Int. 61 2 9887 2114

Nord Amerika

Rosstron Inc
1521 W. 259th St
Harbor City, CA 90710
USA



Telephone: Int. 1 310 539 6293
Fax: Int. 1 310 539 4078

Europa

Controls Dynamic Ltd
Lisle Avenue
Kidderminster
DY11 7DL.
United Kingdom



Telephone Int. 44 1562 820 055
Fax: Int. 44 1562 742 720