

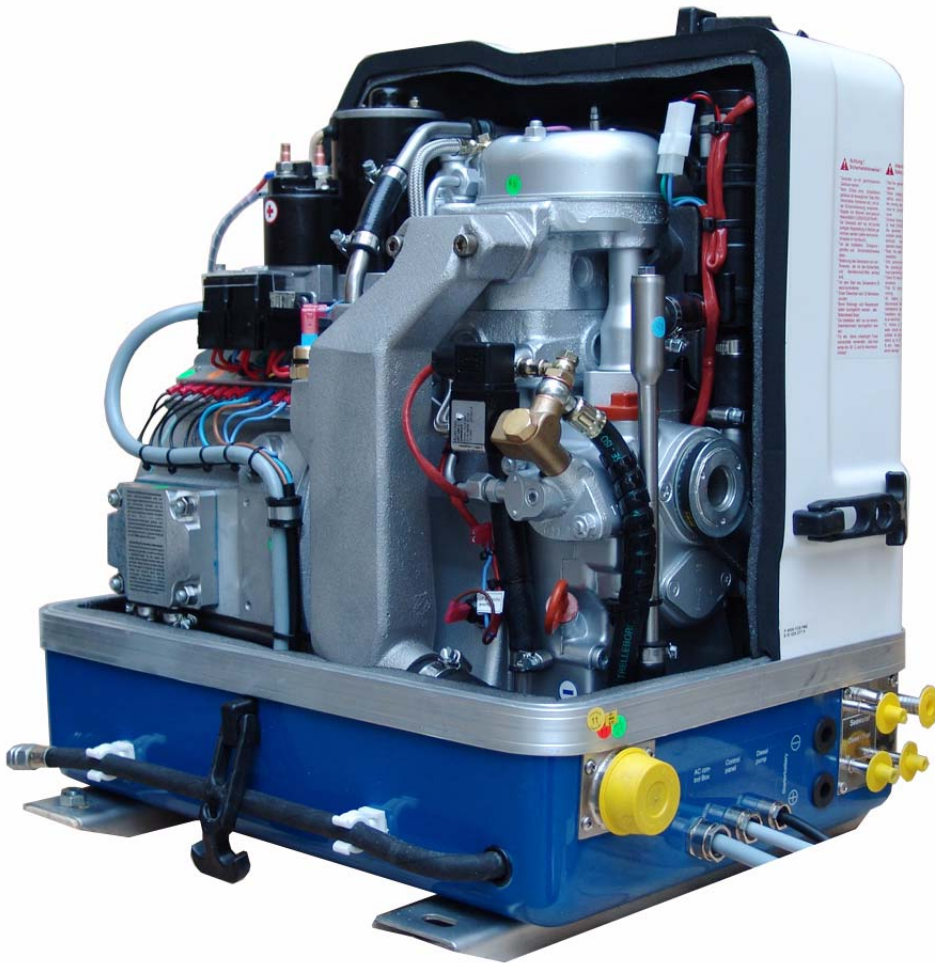

Fischer Panda

Installation manual

Installation, Maintenance and Troubleshooting



Marine Generator Panda PMS 4500 FCB Super silent technology





230 V - 50 Hz / 3,8 kW

Icemaster Fischer Panda

Current revision status

	Document
Actual:	PMS_4500_FCB_manual.V02_15.7.05
Replace:	PMS_4500_FCB_manual_29.10.04

Revision	Page
Chapter C.2.2 Picture of VCS deleted	29
Chapter C.3.1 Picture changed	30
Chapter C.8.3 Pictures changed	60
Chapter C.8.4 Picture and text changed	61

				
since 1977 Icemaster GmbH	since 1978 Fischer Marine Generators	since 1988 Conclusion Fischer - Icemaster GmbH	since 1988 100 % water cooled Panda generators	since 1988 Panda Vehicle Generators

Fischer Panda

FISCHER GENERATORS have been manufactured since 1978 and are a well-known brand for first class diesel generators with especially effective sound-insulation.

Fischer has been one of the leading manufacturers in respect of quality and know-how during this period.

FISCHER, as the worldwide manufacturer of modern marine diesel generators, developed the Sailor-Silent series for example and produced a GFK sound-insulated capsule as early as 1979 and the basis for new generator technology.

The companies Fischer and Icemaster amalgamated under the direction of Icemaster in 1988, in order to concentrate on the development of new products. Production was moved to Paderborn.

The amalgamation of the two qualified companies led to the development of a complete new programme within a short space of time. The gensets developed at that time set new technological standards worldwide.

The gensets became more efficient and powerful than other gensets in the same nominal performance range, because of the improved cooling. Panda generator demonstrated its superiority in several tests by renowned institutes and magazines during the past years. The patented VCS (voltage Control System) means it can meet all demands including motor speed. The start-booster (ASB) means Panda generators meet the highest demands in respect of voltage stability and starting values A Panda generator, with the same drive motor, produces 15% more effective output than the majority of conventional generators. This superiority in efficiency also ensures a fuel saving to the same extent.

The 100% water-cooled Panda gensets are currently manufactured in the performance range from 2 to 100 kW in various versions. Fast running motors are preferred for performances up to approx 30 kW (Nominal speed 3000 rpm). The heavier slow runners are preferred for the higher range. The fast running gensets have proved themselves many times for many uses, that they meet the demands in quality of yachts and vehicles, and offer space and weight saving of 50% compared to slow running generators.

In addition to the Panda series, Icemaster also supply the super compact high-tech sound-insulated battery charging genset from the DC/AC Panda AGT series, which is a very interesting solution for the production of mobile power.

The new HTG-alternators ensure that a charging rate of 285 amps is achieved that was scarcely thought possible for this compact construction. This alternator replaces a separate shipboard generators (constant 230 volts AC with up to 3500 kW from the main machine)

ICEMASTER GmbH, 33104 Paderborn, reserves all rights regarding text and graphics. Details are given to the best of our knowledge. No liability is accepted for correctness. Technical modifications for improving the product without previous notice may be undertaken without notice. Before installation, it must be ensured that the Pictures, diagrams and related material are applicable to the genset supplied. Enquiries must be made in case o doubt.

CALIFORNIA

Proposition 65 Warning

Diesel engine exhaust and some of its constituents are known to the State of California to cause cancer, birth defects, and other reproductive harm.



Attention, Important Directions regarding Operation!

1. The installation certificate must be completed when taken into use, and certified by a signature.
2. The installation certificate must be despatched within two weeks of use to ICEMASTER.
3. The official guaranty confirmation will be completed by ICEMASTER after receipt and sent to the customer.
4. A guaranty must be shown to make any claims.

Claims against the guaranty will not be accepted if the above said instructions are not, or only partially, carried out.

Manufacturer declaration in terms of the machine guideline 98/37/EG .

The generator is in such a way developed that all assembly groups correspond to the CE guidelines. If machine guideline 98/37/EG is applicable, then it is forbidden to bring the generator into operation until it has been determined that the system into which the generator is to be installed also corresponds to the regulations of the machine guideline 98/37/EG. This concerns among other things the exhaust system, cooling system and the electrical installation.

The evaluation of the "protection against contact" can only be accomplished in connection with the respective system. Likewise among other things responsibility for correct electrical connections, a safe ground wire connection, foreign body and humidity protection, protection against humidity due to excessive condensation as well as the overheating through appropriate and inappropriate use in its installed state on the respective machine lies within the responsibility of those who undertake installation of the generator in the system.

Use the advantages of the customer registration:

- Thus you receive extended product informations, which are sometimes safety-relevant
- you receive, if necessarily free Upgrades

Far advantages:

By your full information Fischer Panda technicians can give you fast assistance, since 90% of the disturbances result from errors in the periphery.

Problems due to errors in the installation can be recognized in the apron.

Technical Support by Internet: info@fischerpanda.com

Safety Instructions



The electrical Installations may only be carried out by trained and tested personnel!

The generator may not be taken into use with the cover removed.

The rotating parts (belt-pulley, belts, etc) must be so covered and protected do that there is no danger to life and body!

If a sound insulation covering must be produced at the place of installation, then well-placed signs must show that the generator can only be switched on with a closed capsule.

All servicing-, maintenance or repair work may only carried out, when the motor is not running.

Electrical voltages above 48 volts (battery chargers greater than 36 volts) are always dangerous to life). The rules of the respective regional authority must be adhered to. Only an electrician may carry out installation of the electrical connections for safety reasons.

Protective Conductor:

The generator is „earthed " as standard (The centre and earth are connected by means of a bridge in the generator terminal box). This is a basic safety function, which offers basic safety as long as no other component has been installed. It is, above all, conceived for supply and an eventual test run.

This "earth" (PEN) is only effective, if all parts of the electrical system is earthed, and has a common "potential". The bridges can be removed, if this is required for technical reasons and another protection system has been installed.

The full voltage is exploited at the AC control box, when the generator is run. It must therefore be ensured that the control box is closed and cannot be tampered with, if the generator is running.

The battery must always be disconnected, if work on the generator or electrical system is to be carried out, so that the generator cannot be unintentionally started.

It is not allowed to disconnect the battery during operation!

After the generator has stopped the battery can be disconnected!

Switch off all load when working on the generator

All load must be disconnected, in order to avoid damages to the devices. In addition the semi conductors in the AC control box must be disconnected in order to avoid the boat capacitors being activated. The minus pole of the battery ought to be removed.

Capacitors are required to run the generator. These have two varying functions:

A) The working capacitors

B) The (Booster) capacitors

Both Groups are located in a separate AC-Control box.

Capacitors are electrical stores. There could be a residual of high electrical current at the contacts for a period disconnection from the circuit. The contacts my not be touched for safety reasons, If the capacitors are to be exchanged or checked, then a short circuit between the contacts should be made so that the stored energy is discharged.

If the generator is switched off in the normal manner, the working capacitors are automatically discharged by means of the windings. The booster capacitors are discharged by means of internal discharge resistors.

All capacitors must be short-circuited before work is carried out on the AC-Control box for safety reasons.

Table of contents

A	Mode of Operation of the Generator	5
A.1	Mode of operation of operating surveillance	5
A.1.1	Regulation of the generator voltage by the VCS	7
A.1.2	Overloading of engine during longer operation	7
A.2	Operation of electric motors with high starting current	7
A.2.1	General references.....	7
A.2.2	Compensation of 1 phases engines	8
A.2.3	Compensation of 3 phases engines	8
A.3	Operation of the generator with additional units	8
A.3.1	General references.....	8
A.4	Operation of the generator with HTG generator	9
A.4.1	General references.....	9
A.5	Operation of generator with installation under the waterline	9
A.5.1	Control of the ventilation valve	10
A.6	Operation of generator with installation over the waterline	11
B	Maintenance Instructions	13
B.1	General maintenance instructions	13
B.1.1	Checks before starting	13
B.1.2	Hose elements and rubber formed component in the sound cover.....	13
B.2	Oil circuit maintenance	13
B.3	Execution of an oil change	14
B.3.1	De-aerating the fuel system	16
B.3.2	Exchange of the fuel filter.....	16
B.4	Checking the water separator in the fuel supply	17
B.4.1	Exchange the air filter mat.....	17
B.5	De-aerating of the coolant circuit / freshwater	18
B.5.1	Draining the coolant	20
B.5.2	Exchange of the toothed-belt for the internal cooling water pump	20
B.6	The raw water circuit	21
B.6.1	Clean raw water filter.....	21
B.7	Causes with frequent impeller waste	22
B.7.1	Exchange of the impeller.....	22
B.8	Coolant connection block at generator housing	24
B.9	Conservation at longer operation interruption	25
B.9.1	Measures on preparation of the winter storage.....	25
B.9.2	Initiation at spring	26
C	Generator Failure	27
C.1	Tools and measuring instruments	27
C.2	Overloading the Generator	27
C.2.1	Monitoring the Generator Voltage	28
C.2.2	Automatic Voltage Monitoring and Auto-Shut Down	28

C.3	Low Generator-Output Voltage	30
C.3.1	Discharge the capacitors	30
C.3.2	Checking the capacitors	31
C.3.3	Checking the generator voltage	32
C.3.4	Measuring the coil resistance	32
C.3.5	Checking the coil(s) to short-circuit	33
C.3.6	Measuring the inductive resistance	33
C.4	Generator provides no Voltage	34
C.4.1	Rotor Magnetism Loss and "Re-magnetizing"	34
C.5	Starting Problems	34
C.5.1	Starting with a weak Battery	34
C.5.2	Fuel Solenoid Valve	35
C.5.3	Troubleshooting Table	36
D	Installation Instructions	37
D.1	Placement	37
D.1.1	Placement and Basemount	37
D.1.2	Notice for optimal sound insulation	37
D.2	Generator Connections - Scheme	38
D.3	Cooling System Installation - Raw water	39
D.3.1	General References	39
D.3.2	Installation of the thru-vessel fitting in Yachts	39
D.3.3	Quality of the raw water sucking in line	39
D.3.4	Installation above waterline	40
D.3.5	Installation below waterline	41
D.3.6	Installation under the waterline	42
D.3.7	Installation over the waterline	43
D.4	The Freshwater - Coolant Circuit	44
D.4.1	Position of the external Cooling Water Expansion Tank	44
D.4.2	Scheme for fresh water circuit	44
D.4.3	De-aerating at the first filling of the internal cooling water circuit	45
D.4.4	Filling and de-aerating of the internal cooling water circuit	46
D.4.5	Pressure test for control of cooling water circuit	47
D.5	Watercooled Exhaust System	48
D.5.1	Installation of the standard exhaust system	48
D.5.2	Exhaust / water separator	49
D.5.3	Installation exhaust/water separator	50
D.6	Fuel System Installation	51
D.6.1	General References	51
D.6.2	The electrical fuel pump	52
D.6.3	Connection of the fuel lines at the tank	52
D.6.4	Position of the pre-filter with water separator	53
D.6.5	De-aerating the fuel system	53
D.7	Generator 12V DC System-Installation	54
D.7.1	Connection of the 12V starter battery	54
D.7.2	Connection of the remote control panel	55
D.7.3	The speed sensor	56
D.7.4	Electronic starter control unit	56
D.8	Generator AC System-Installation	57
D.8.1	Installation with looped in AC-Control box	57
D.8.2	Installation AC-Box / distribution panel separate connected	58

D.8.3	AC-Control box with VCS and ASB	60
D.8.4	Booster electronic.....	61
D.8.5	Jump start at high starting current (Booster)	62
D.9	Insulation test	62
D.10	Voltage controller	63
D.10.1	Adjustment of the rated voltage.....	63
D.10.2	Functional description of the voltage controller	63
D.10.3	Time lag of the switching points	64
F	Tables	I
F.1	Troubleshooting	I
F.2	Technical Data Engine	V
F.3	Technical Data Generator	VI
F.4	Types of coil	VII
F.5	Inspection checklist for services	VIII
F.6	Engine oil	IX
F.7	Coolant	X
F.8	Capsule Measurements	XI
F.9	Cooling water flow Panda 4500 FCB	XII

A. Mode of Operation of the Generator

A.1 Mode of operation of operating surveillance

Internal monitoring switches

The generator is equipped about failure switches, which are indicated on the remote control panel, and also about failure switch, which switch-off the generator automatically without indicating a failure in the remote control panel:

The remote control panel supervised the following values. In the case of a disturbance the generator is switched off, in order to avoid damage to the aggregate:

1. Cooling water temperature at cylinder head and exhaust connection
2. Coil temperature
3. Oil pressure

The fault is transmitted, if one of these switches measures a value that exceeds the required value (all switches are openers). The current is switched off by the main relay. (Fuel magnet valve closes, the fuel suction pump is switched off, VCS is switched off).

The combustion engine possesses an oil pressure control switch, which switches the engine off if the oil pressure drops under a certain value.

The additional failure switch in the generator coil, it is not indicated at the remote control panel, interrupts directly the current supply to the main power relay. By this constellation it is guaranteed that the generator switches off in each case when an error is present.

This measure is, if possibly, a circuit at the remote control panel failed.

Thermo-switch at cylinder head



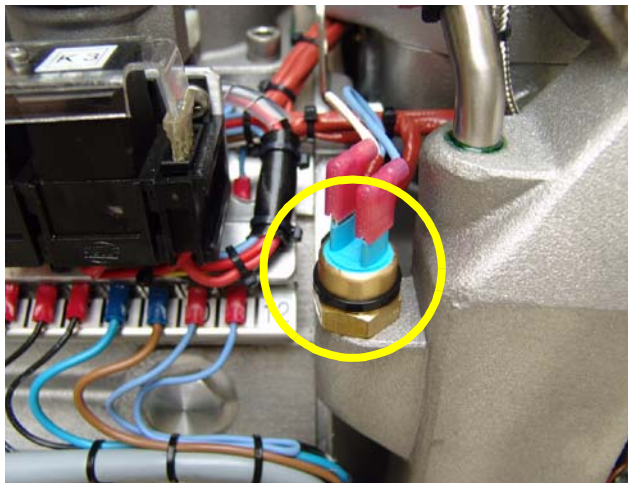

Thermo-switch exhaust elbow

If the impeller pump should fail, the raw water stream fed here tears off and the exhaust elbow heats up immediately extremely fast, since the cooling water is missing. The thermo-switch supervises thus a functioning raw water cycle.

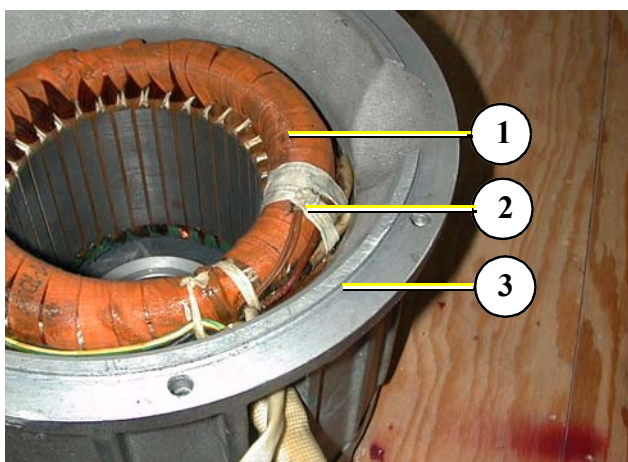

Thermo-switch in the generator coil

1. Generator coil
2. Thermo-switch
3. Housing

For the protection of the generator coil there are two thermo-switches inside the coil, which are for inserted parallel and safety's sake independently from each other.

Fig. A.1: Thermo-switch coil

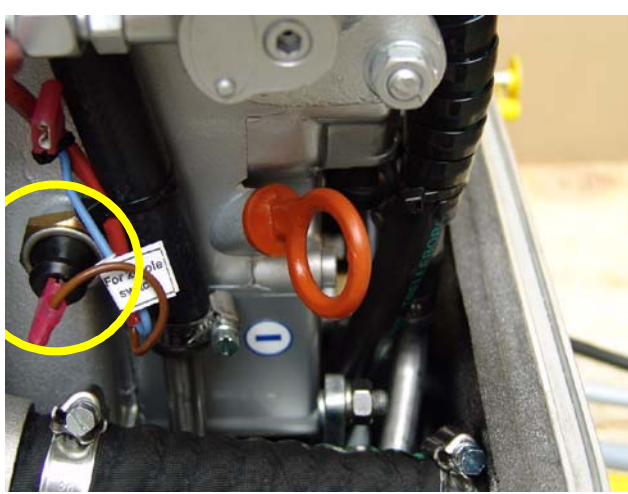

Oil pressure switch

The combustion engine possesses an oil pressure control switch, which switches the engine off if the oil pressure drops under a certain value.

A.1.1 Regulation of the generator voltage by the VCS

The output voltage of the generator is permanently measured by the VCS (approx. 20 times per second!). As soon as by a consumer the voltage is affected, the speed regulation provides to adapt to the changed power demand by appropriate change of the engine speed. Not only by the excitation of the generator it is worked against to the initiating voltage drop, but also by the raising of the number of revolutions whereby the drive potential improves.

A.1.2 Overloading of engine during longer operation

Please ensure that the genset is not overloaded. Overloading occurs when the electrical load (demand) induces a load torque in the generator which is higher than that which the diesel drive motor can provide. Overloading causes the engine to run rough, burn oil, creates excessive exhaust (environmentally unfriendly) and even to stall. Extra caution should be practised with multi-power units (single and 3-phase current generation) to avoid overloading the diesel drive engine.

The generator should only be loaded at the peak rated power for short periods only! A high peak current is required to start many electrical devices, especially electric motors and compressors (from a still stand state).

The height of the rated output (P) can taken from the identification plate attached on the housing.

In order to guarantee a long life span, the continuous load should not exceed 80% of the nominal load. By continuous output we understand the continuous operation of the generator over many hours. It is harmless for the engine to supply for 2-3 hours the full rated output.



The total conception of the Panda generator guarantees that the continuous load operation does not release superelevated temperatures of the engine also with extreme conditions. It is to be considered that the exhaust gas values in the full load operation become more unfavorable (soot formation).

A.2 Operation of electric motors with high starting current

A.2.1 General references

Electric motors can need for a very short time an increased starting current when starting. The starting current can amount to up to 10 times of the rated current. This applies in particular to 2-pole engines and particularly to fan engines with larger power, in addition, to engines, which compressor with flywheels or the like propels. If such engines are to be operated, contact the technician of Fischer Panda, in order to find suitable measures, which work against the high starting current and/or layout the generator for the higher starting current.

A.2.2 Compensation of 1 phases engines

If inductive electrical consumers are connected, then there is a phase shift between current and voltage; the portion of the blind current becomes larger. This effect meets by automatic activating of additional capacitors and compensates the idle current. This compensation of the inductive consumers causes that the efficiency of the generator is increased. By the automatic compensation can more engines or a larger electrical load with an inductive character be operated. In other words: the usable power of the generator is increased.

A.2.3 Compensation of 3 phases engines

See „Bimetallic Corrosion (Electrolysis)“ in the appendix.

A.3 Operation of the generator with additional units

A.3.1 General references

The Panda generator is arranged that the operation of additional aggregates, which are flanged on directly to the front cover of the generator, is possible. If such aggregates are intended, this - if possible - should be considered with the order of the generator. With the mounting of additional hydraulic pumps the employment of an electrical separation clutch is always recommended. The appropriate components are available for the different generator types. It is caused that the additional hydraulic pump is in operation even if it is actually used.

Depending upon power of the additionally appropriate aggregates the power is reduced, which can put the combustion engine to the generator at the disposal.



Panda generator with electrically adjustable clutch

A.4 Operation of the generator with HTG generator

A.4.1 General references

Beside the alternating current aggregates ICEMASTER supplies also the super-compact High tech battery load aggregates from the series of PANDA AGT in sound-insulated construction, which represent a very interesting alternative solution in a DC-AC power technology merged for generation of current within the mobile range. The new HTG generators with 280 A charging current offer themselves a alternative for an onboard current generator, if a diesel set is not intended. These generators differ according to the technology very substantially from all conventional products. The size is so compact that you can exchange it also against a generator according to standard. This generator can ensure a 230V alternating current supply up to 3.000W power in connection with a PANDA HD inverter also in continuous operation.

A.5 Operation of generator with installation under the waterline

If the generator cannot be installed clearly at least 600mm over the waterline, a ventilation valve must be installed into the raw water line. At installation beside the "midship's line" a possible heeling must be considered!

The water hose in the sound cover is split on the pressure side of the pump and extended in each case in the sound cover at both ends with a connecting nipple by a hose end. Both hose ends must led out from the sound cover to a point, which is at least for 600mm over the waterline (if possible in the midship's line). The valve is inserted at the highest place, at least 600mm over the waterline.

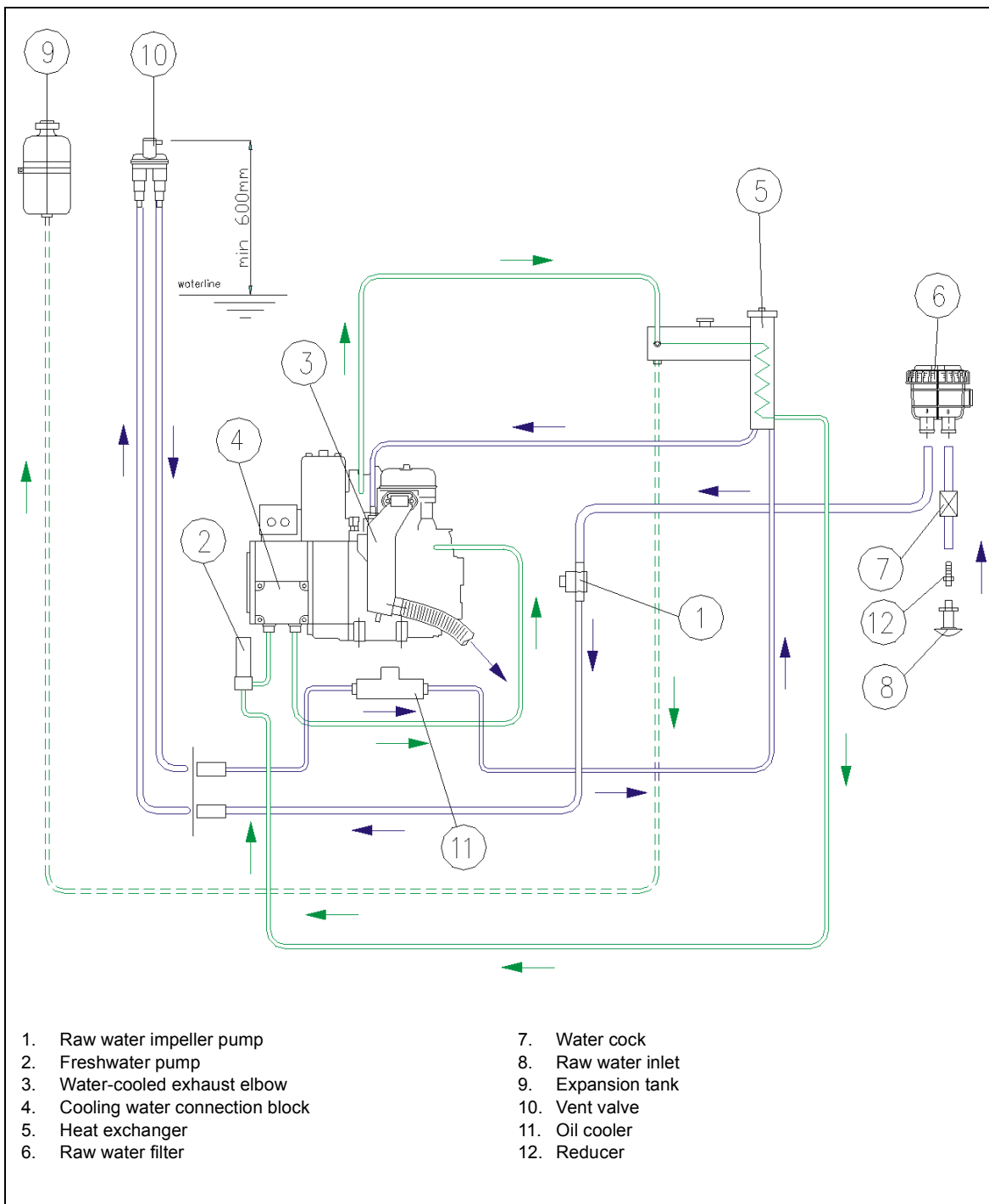

A.5.1 Control of the ventilation valve

If the valve is blocked, the cooling water pipe cannot be ventilated after the stop of the generator, the water column is not interrupted and the water can penetrate into the combustion chamber of the engine.

This lead to destruction of the engine!

A.6 Operation of generator with installation over the waterline

Generator over the waterline:

If the generator is installed over the waterline, a stronger impeller wear is possible, the pump can run after the start some seconds dry.

It is very important that the impeller is exchanged every few months. When starting the generator attention should be always paid and heard to it, when raw water withdraws from the exhaust neck. If this takes longer than 5 seconds the impeller must be exchanged, he sucks in air before raw water reaches the impeller (see picture below) and the impeller then wears strongly. In this case the impeller loses his effect and raw water can penetrate into the engine as well as substantially destroy it. If the impeller is not exchanged early enough, the entire pump must be replaced. Otherwise the impeller wings breaks in pieces and it stresses some time to remove these again. Replacement impeller should always be on board.

With the installation of the generator it must be paid attention that the impeller pump is well accessible, since the impeller is a wearing part. If this place at the location can be reached not well, an external pump with electric drive can be used instead of the pump built firmly in the sound cover, which should be installed in a well accessible place.

1. Raw water filter
2. Water cock
3. Hull inlet

Make certain that the raw water filter lies above the water level, otherwise with cleaning water can penetrate by the hull inlet.

An external pre-pump can relieve the impeller.

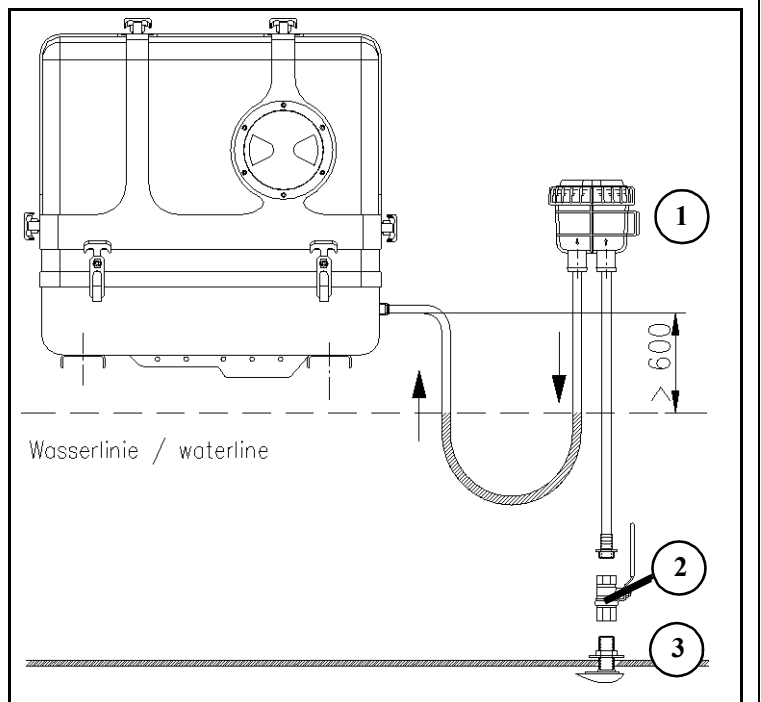

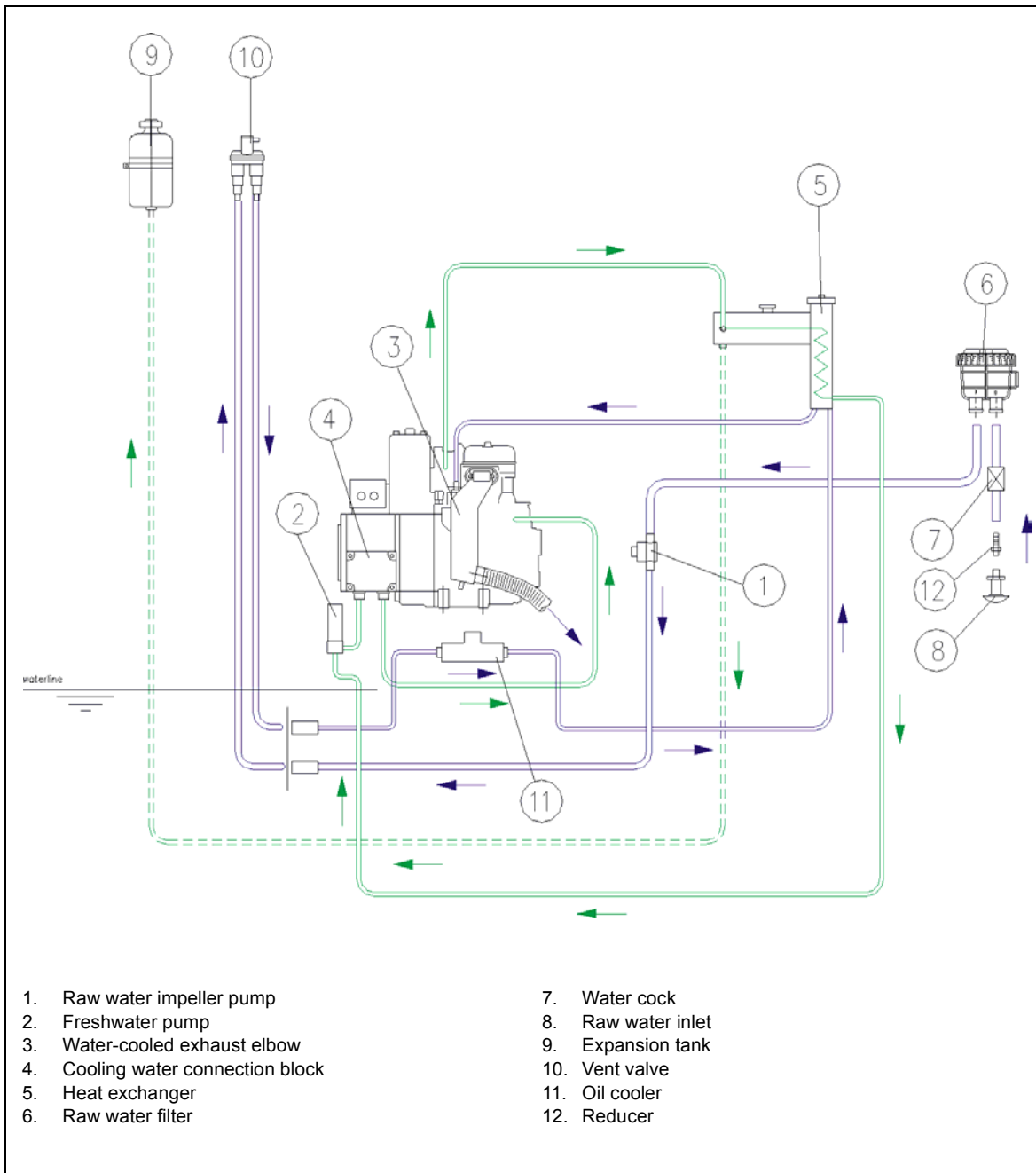

B. Maintenance Instructions

B.1 General maintenance instructions

B.1.1 Checks before starting

- Oil level
- Cooling system leaks
- Visual check for any changes, leaks oil drain system, v-belt, cable connections, hose clips, air filter, fuel lines

B.1.2 Hose elements and rubber formed component in the sound cover

Check all hoses and hose connections for good condition. The rubber hoses are very sensitive to environmental influences. They can season fast with dry air, in which environment of muted oil and fuel steams and increased temperature. The hoses must be checked regularly for elasticity. There are operating situations, at which the hoses must be renewed once in the year.

Additionally to usual tasks of maintenance (oil level check, oil filter control etc.) further maintenance activities are to be accomplished for marine aggregates. It belongs control of the sacrificial anode (cooling water connection block) and the front seal cover at the generator.

For maintenance intervalls see Table F.5, "Inspection checklist for services," on Page VIII.

B.2 Oil circuit maintenance

The first oil change is to be accomplished after a period of operation from 35 to 50 hours. Afterwards the oil is to be changed after 100 hours. For this the oil SAE30 for temperatures over 20°C and SAE20 for temperatures between 5°C and 20°C is to be used. At temperatures under 5°C oil of the viscosity SAE10W or 10W-30 is prescribed.

Type and amount of required oil see:

See "Engine oil" on page IX and "Technical Data Engine" on page V.

B.3 Execution of an oil change

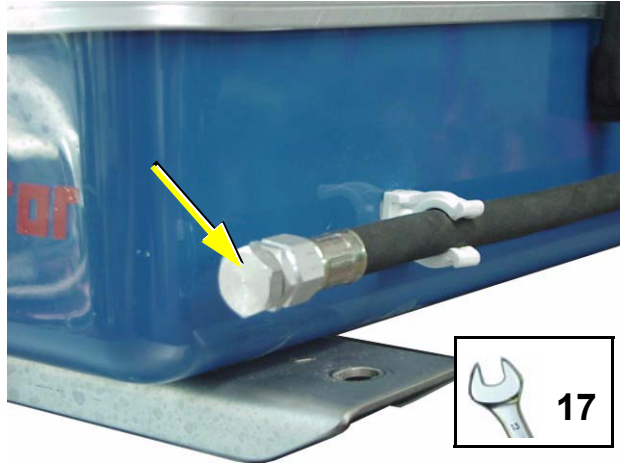

Oil drain screw

For the oil change an oil drain hose is lead through the sound cover.

The oil can be discharged by opening the oil drain screw. For countering use a second wrench.



Oil drain pump

If discharging of the oil is not possible, we recommend the employment of a hand pump, which can be attached to the oil drain hose.

Afterwards the oil drain screw is closed again.

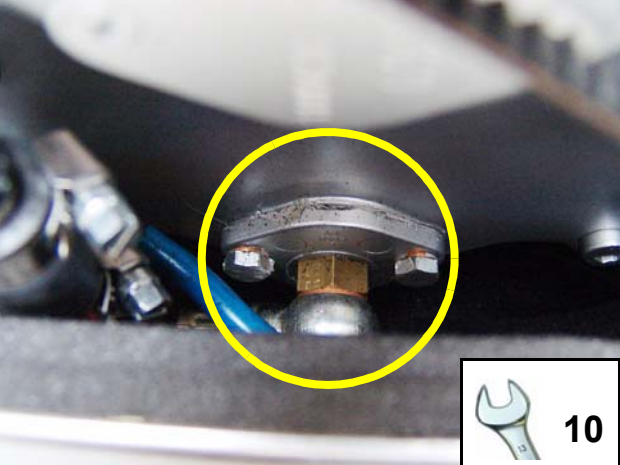

Oil strainer

The Farymann engine type 18W430 is not equipped with a replaceable oil filter. Instead the engine has an oil strainer (at the face down, see picture). The strainer is to be cleaned every 500 hours. For this the engine must be lifted with the front from the sound cover. The Panda 4200 possesses an oil drain hose at the oil strainer for discharging the engine oil with the oil change.





Open the oil filler neck

After opening the cap of the oil filler neck the new oil is refilled.

Please wait instant, before measure the oil level, the oil must set off in the sump.

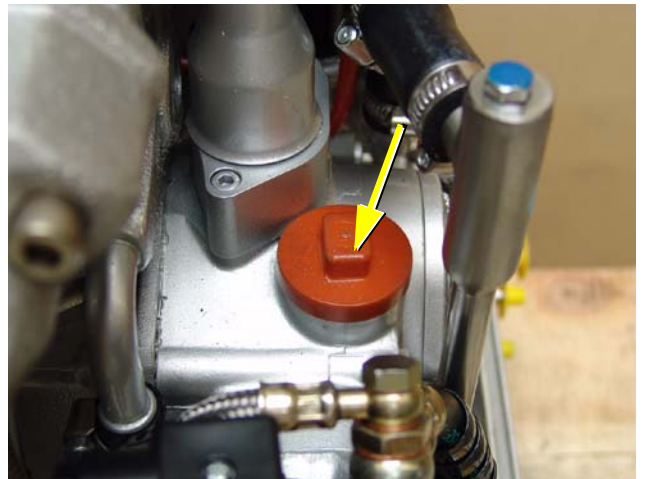

Oil dipstick

With the help of the engine oil dipstick the oil level is to examined. The prescribed filling level may not exceed the „Max“ marking.

We recommend 2/3 oil level.

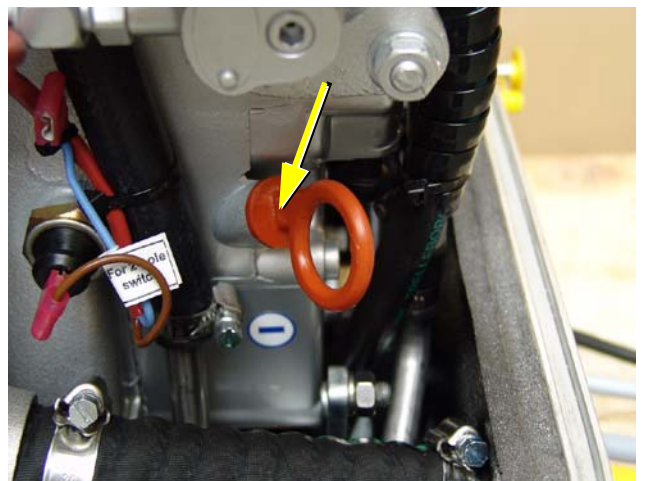

B.3.1 De-aerating the fuel system

Normally, the fuel system is designed to bleed out air itself i.e. as soon as the electric starter motor starts operation the fuel pump starts working and the fuel system will be de-aerated after some time automatically. It is nevertheless essential to bleed the system as follows prior to the first operation (as all hoses are empty):

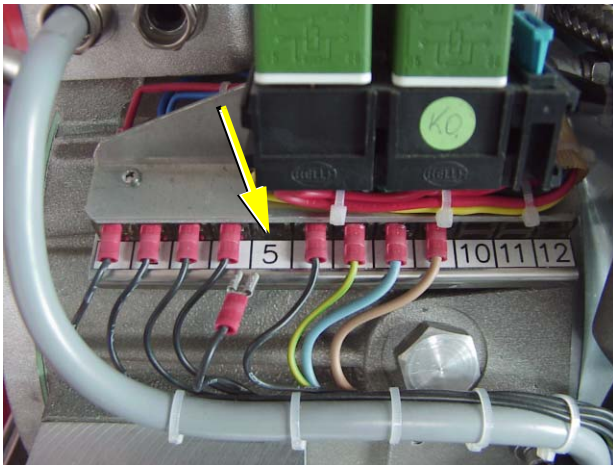

1. Main power switch "OFF".
2. Disconnect clamp no. 5 of the DC-terminal block.
3. Main power switch "ON" for approximately 30 minutes (the electrical fuel pump starts and airs out automatically the fuel inlet).
Do not press the "START"-button!
4. Main power switch "OFF".
5. Reconnect clamp no. 5 of the DC-terminal block.

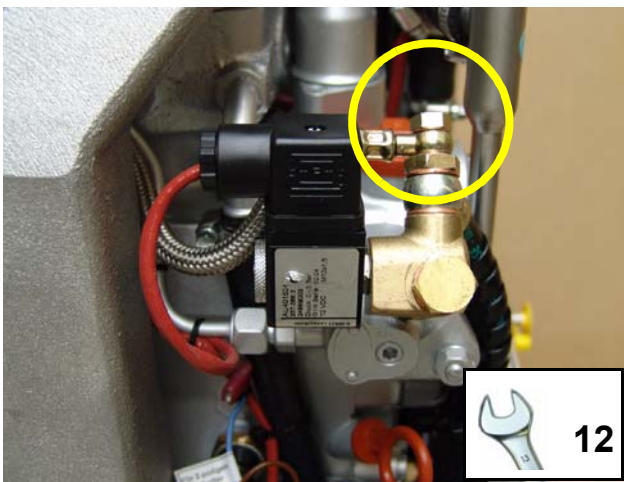

If still bubbles are in the fuel inlets, the ventilation screw at the fuel solenoid valve (or the union nut at the injection line at the cylinder head) should be opened and the procedure has to be accomplished again. It is advisable to hold an absorbent paper or cloth under the screw so that the fuel does not run in the sound cover. The fuel pump must run only until nonporously fuel withdraws. As soon as the system is aired out, the open screw must be tightened again.

B.3.2 Exchange of the fuel filter



The exchange of the filter depends on the contamination of the fuel, should take place at least all 300 operation hours. Before the exchange of the filter the inlet must be clamped.

Remove the hoses from the used filter and fasten them to the new filter. The arrow on the filter housing indicates the direction of the fuel flow. A clogged filter causes a decreased power output of the generator.

B.4 Checking the water separator in the fuel supply

The pre-filter with water separator has a cock at its lower surface, with this cock the downward sunk water can be discharged.

This is simply possible, water is heavier due to its density than the Diesel.

This pre-filter does not belong to the scope of supply.



B.4.1 Exchange the air filter mat

Open the air suction housing by loosen the six screws on the housing cover.

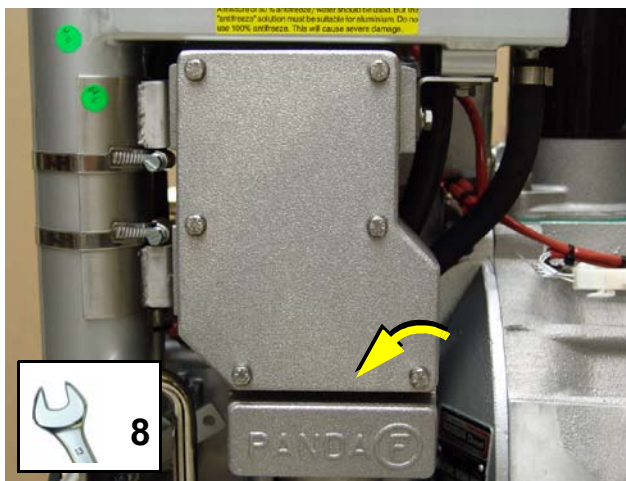

Change the air filter mat.

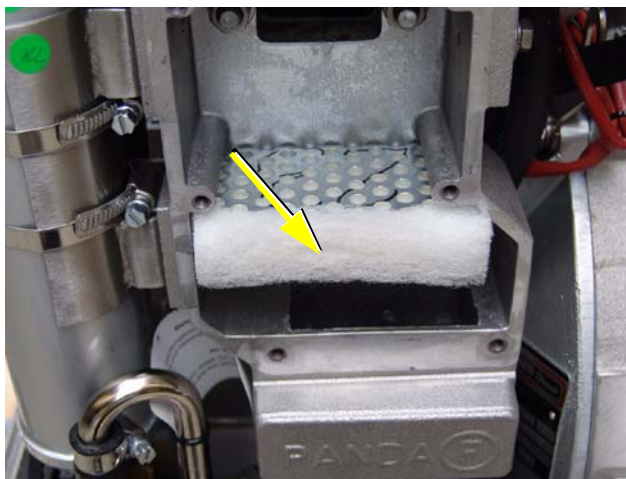

B.5 De-aerating of the coolant circuit / freshwater

Special notes for the ventilation of the cooling system

If the cooling water is drained or if other air should have arrived into the cooling system, it is necessary to de-aerate the cooling system. This de-aerate procedure must be repeated several times:

ATTENTION ! Before opening the de-aerating points the generator must be stagnant !!!

Pay attention that the external coolant expansion tank is connected with the generator by the intended connection point. Further it should be guaranteed that the expansion tank is attached in sufficient height (600mm) over the level of the generator exhaust elbow union.

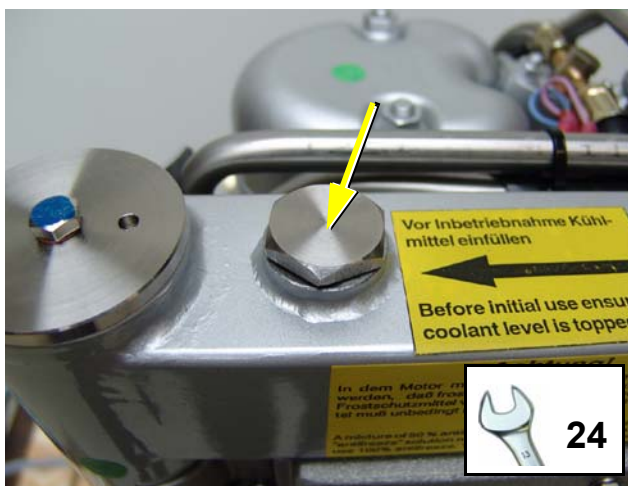

Open the cooling water filler screw.



The coolant must be refilled so long, up to recognizes that the cooling water level does not sag any longer.

Then close the screw again and start the generator. Run the generator about 1 min. and switch off again.

Now the cooling water is only filled over the external expansion tank. This is connected by a hose with the aggregate.

The external expansion tank should be filled in the cold condition only up to maximally 20%. It is very important that a large extension space over the cooling water level remains.

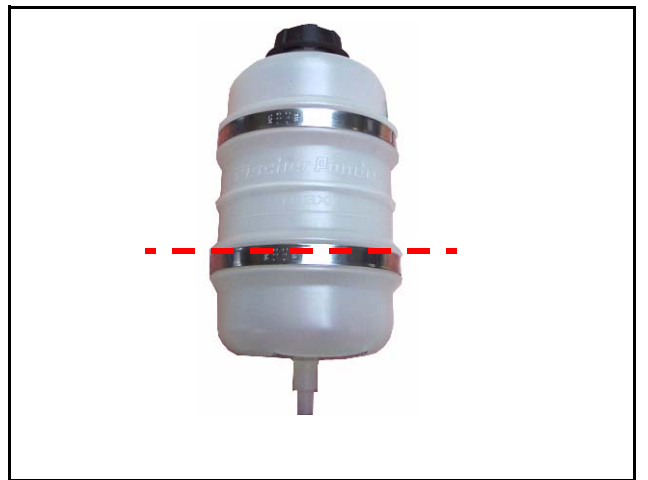

Open the ventilation screw at the pipe of the cooling water pump.

The out-stepping water must be observed. This must be nonporous, in order to place surely that no air is in the water circulation.

Close the screw again firmly.

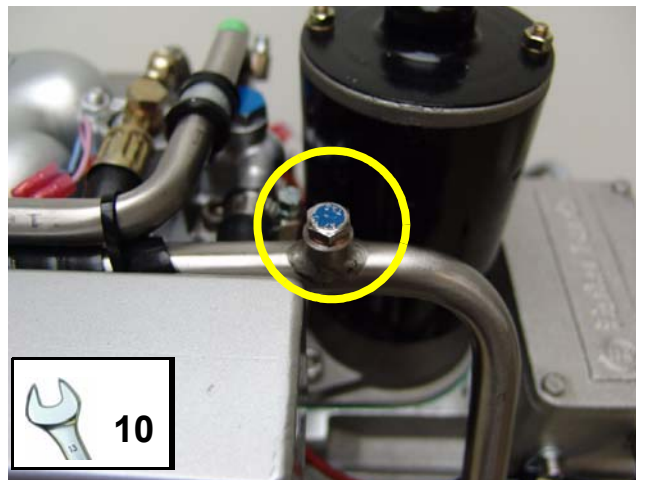

The ventilation screw above the heat exchanger can remain closed.

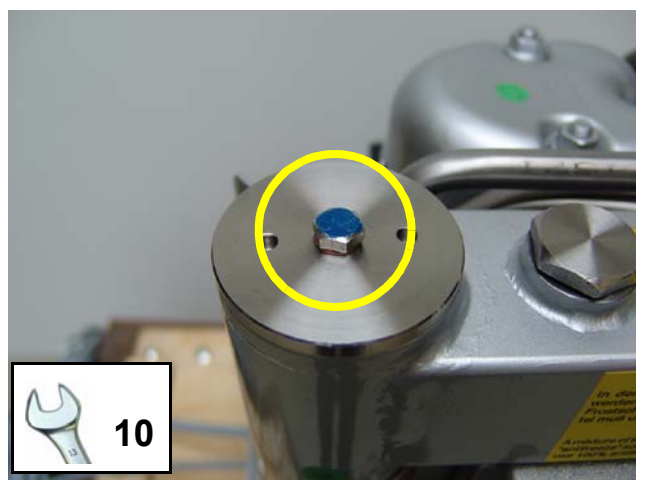

If no change of the cooling water level can be determined, the generator is started for 5 minutes. Afterwards repeat the de-aeration two - three times.

It is meaningful to repeat the de-aeration procedure also after some days again to guarantee that in the system remained bubbles are removed.

B.5.1 Draining the coolant

In principle only describes here, how the cooling water of the raw water cycle can be drained. The mixture of the fresh water circuit should not be drained in principle. See measures for the preparation of the winter storage.



The simplest and cleanest method consists of the fact to bring the external ventilation valve below the generator level and hold over a collecting basin. Open the valve now, the water from the raw water circuit flows downward into the container.

B.5.2 Exchange of the toothed-belt for the internal cooling water pump

The relative high ambient temperature in the closed sound insulated capsule (about 85°C) can be a reason for a reduced lifespan of the toothed-belts. It is possible that the "softener" in the rubber compound lose their effect after a short operating time because the air in the sound insulated capsule can be relative warm and dry.

The toothed-belt must be controlled in a very short time interval. It can be happen to change the toothed-belt after some weeks because of unfavorably conditions. Therefore the control is needed in an interval of 100 operating hours. The toothed-belt ia a wearing part. It should be enough spare toothed-belts on board. We suggest to stand by the according service-packet.



Push the toothed-belt carefully down with a screwdriver of the pulley toward water pump. The new toothed-belt can fit in by careful moving back and forth again on the pulley. Also here a screwdriver can be helpful.

Type of belt: Gates Power Grip GT MR L660 5MR 475 6 692

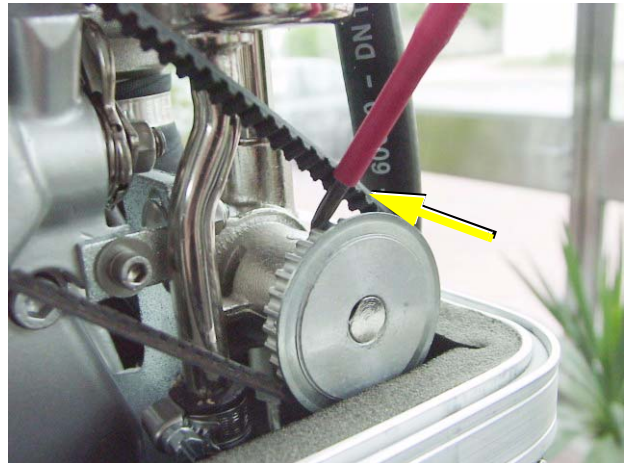

B.6 The raw water circuit

B.6.1 Clean raw water filter

The raw water filter should be released regularly from arrears. In each case the water cock must be closed before. It is mostly sufficient to beat the filter punnet.

If water should seep through the cover of the raw water filter, this may be sealed in no case with adhesive or sealant. Rather must be searched for the cause for the leakage. In the simplest case the sealing ring between caps and filter holders must be exchanged.



B.7 Causes with frequent impeller waste

The impeller of the cooling water pump must be regarded as wearing part. The life span of the impeller can be extremely different and exclusively depends on the operating conditions. The cooling water pumps of the PANDA generators are laid out in such a way that the number of revolutions of the pump lies low compared with other aggregates. This is for the life span of the pump a positive effect. Unfavorably affects the life span of the impeller, if the cooling water sucking in way is relatively long or the supply is handicapped, so that the cooling water sucking in range develops a negative pressure. This can reduce first of all the power of the cooling water pump extremely that the wings of the impeller are exposed to very strong loads. This can shorten the life span extremely. Further the operation of the impeller pump loaded in waters with a high portion of suspended matters. The use of the impeller pump is particularly critical in coral waterbodies. Cases are well-known, which a impeller pump had so strongly run after 100 hours already that the lip seal on the wave was ground in. In these cases sharp crystal parts of the coral sand assess in the rubber seal and affect like an abrasive the high-grade steel shank of the impeller pump. If the generator were mounted over the water level it is particularly unfavorable for the impeller pump. After the first start some seconds will pass by, until the impeller can suck in cooling water. This short unlubricated operation time damages the impeller. The increased wear can lead after short time to the loss. (see special notes: "Effects on the impeller pump, if the generator is mounted over the waterline")

B.7.1 Exchange of the impeller

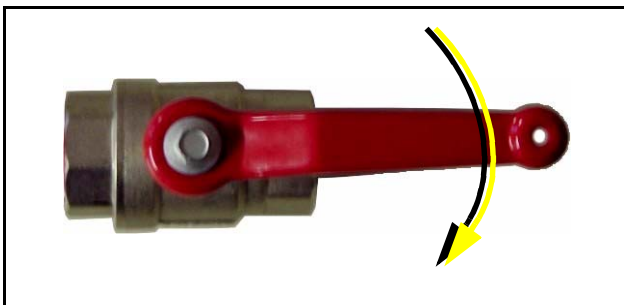

Close the raw water stop cock.

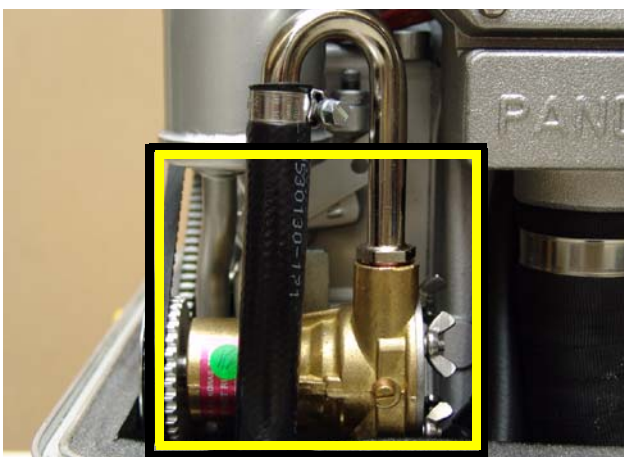

Raw water pump on the front side of the genset.



Remove the cover of the raw water pump by loosen the 4 wing screws from the housing.

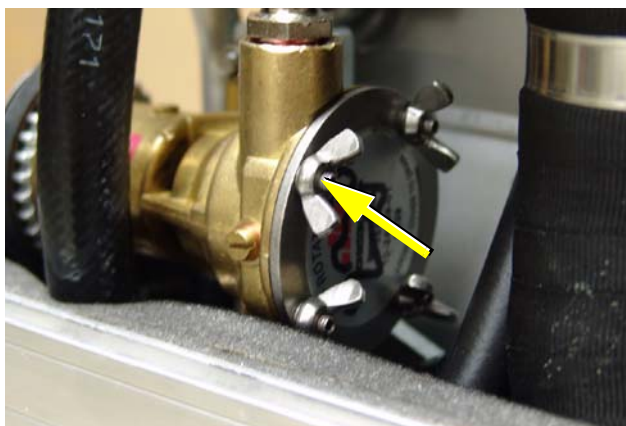

Pull to the impeller with a multigrip pliers of the wave.

Mark the impeller, to make sure that these is used in the correct position at re-installation.

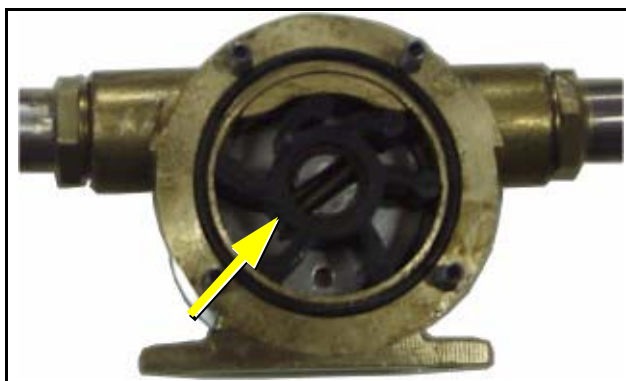

Check to the impeller for damage and replace it if necessary.

Before the reinsertion into the housing the impeller should have been lubricated with glycerin or with a non-mineral oil based lubricant e.g. silicone spray.

Attention - this is very important, because the impeller can dissolve otherwise very fast.



The impeller is attached to the pump wave if the old impeller is used, pay attention to the before attached marking).

Fastening the cover and use a new seal..



B.8 Coolant connection block at generator housing

Monitoring of the coolant connection block as sacrificial anode

At all raw watercooled aggregates the coolant connection block at the side of the generator housing must be well controlled. This coolant connection block is manufactured from a special aluminum alloy and serves also as sacrificial anode. If by the influences of electrical DC voltage the aluminum alloy of the generator is endangered, first the coolant connection block is concerned. If visibly corrosion is identifiable from the outside of the coolant connection block, the block must be changed in regular intervals (at least once per year). In this case the coolant connection block is to be seen as wearing part. It should always be available in each case as spare part on board.

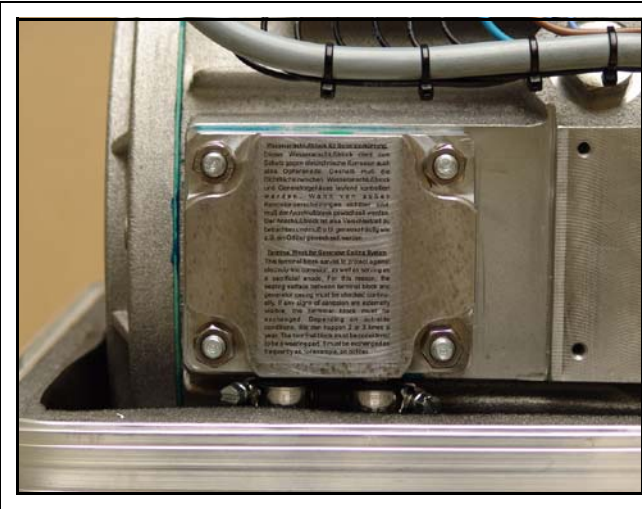

In order to protect the generator housing against corrosion and against electrolysis, the connection block with the cooling water connecting pieces takes the function of a sacrificial anode.

Replacement of the coolant connection block

The coolant connection block is put on with a "Spezial" sealant. The fixing bolts are not intended in order to stretch the coolant connection block closely on the surface area. These screws serve only for the adjustment of the coolant connection block until the sealant is hardened and it reached its final firmness. The fixing bolts may be tightened therefore only sturdy.



ATTENTION! At the side the fixing bolts with an electrically neutral fat (e.g. anti seize) must be used. If the fixing bolts (high-grade steel) turned in without this fat into the aluminum threads, the danger of a corrosion exists, and it is possible that the thread root out when unscrewing the screws.



B.9 Conservation at longer operation interruption



B.9.1 Measures on preparation of the winter storage

1. Rinse raw water circuit with an anti-freeze solution, even if this contains a corrosion protection means. The raw water inlet must be removed at the water cock. Over a hose connector the anti-freeze protection mixture is to be sucked in from a container. The leaked cooling water with the exhaust is to be led back into the sucking in container. The circuit must be kept upright some minutes to guaranteed that the anti-freeze protection mixture reaches all ranges of the cooling system.
2. The concentration of the anti-freeze mixture in the internal cooling circuit must be checked with a suitable measuring instrument. The concentration must be furnished according to the lowest temperatures which can be expected.
3. Clean raw water filter and check seal.
4. Check water cock for practicability. And spray with a corrosion protection oil from the inside or lubricate with acidless grease.
5. Check all hoses and hose connectors for good condition. The rubber hoses are very sensitive to enviromental influences. They can age fast with dry air, in environment of light oil and fuel steams and increased temperature. The hoses must be checked regularly for elasticity. There are operating situations, which the hoses must be renewed once in the year.
6. Check the hose connectors at all raw water valves doubly and if possible protect them with double hose clamps.
7. Dismount the impeller of the cooling water pump and check for wear. The impeller may not remain in the pump. It must be greased with vaseline and be kept at a dark place. It can be reintragrated in the spring again into the pump, if it is in good condition. The impeller is a wearing part, it is recommended to renew it always in the spring, independently how many operating hours the aggregate ran.
8. Control of the vent valve at the raw water inlet. If the generator is installed below the waterline, always a vent valve is necessary. The vent valve must be checked also during the season regularly. In the winter storage the vent valve should always be disassembled, checked and greased. Hardens or got parts dirty are to be replaced.
9. Check water lock: If the generator were rinsed with an anti-freeze mixture, the antifreeze mixture can leave in the water lock. If the generator were rinsed with fresh water, the water in the water lock must be drained. Otherwise the danger exists that the collector is blown up and destroyed by ice.
10. Check the exhaust/water separator on leakage and if the hose connectors at the lower surface of the separation unit are in normal condition. (with extremely sulfureous fuels it is possible that also high-grade steel tube ends are attacked.)
11. Check all construction units at the generator inside the sound cover for leakages. If there are traces of humidity in the sound cover, the cover must be dried. Further the cause for the wetness must be surched and eliminated.
12. During the winter storage the upper section of the sound cover must be taken off, in order to avoid condensed moisture formation, if traces of humidity remain in the sound cover inside casing by leakages in the raw water circuit.
13. The generator housing and the housing of the engine should be sprayed with a corrosion protection oil before the winter storage. This procedure is recommended also in the season. This procedure can avoid that arising and humidity marks on the surface of the aluminum construction units be noticed too late.
14. Disconnect the starter battery (positive and negative pole).

B.9.1 Measures on preparation of the winter storage

15. Lubricate the spindle for the number of revolutions adjustment device with a special lubricant (Antiseize grease).
16. Check cooling water connection block at the generator housing on traces of corrosion and if necessary renew. (only such traces are to be considered, which refer to clear "blossoming" of the material. If the surface is only grey coated, this is only an indication for the fact that aluminum came into contact with condensed moisture.)
17. Use of a air dehumidifier. The best way to protect a yacht in the winter storage against damage by humidity is, to place a air dehumidifier inside the ship and lock all hatches. The devices have a hygrometer, which switches the device off, if the humidity is under the adjusted value. There is no better method, in order to protect pads, cable, electronics, wood, engines etc. optimally against any rotting by humidity.

B.9.2 Initiation at spring

- Before the first start turn the engine once with the hand, in order to eliminate necessary existing corrosion beginnings in the bushing. If necessarily carry out normal engine inspection.
- Change engine oil and engine oil filters.
- Reintegrate the impeller of the cooling water pump and check pump for leakage.
- Charge starter battery of the generator, connect cables and check battery voltage.
- Start generator and check the basic adjustments of the generator such as voltage, speed regulation etc..
- Check all switching off devices for function by operational procedures.

Icemaster does not take over adhesion for possible damages!

C. Generator Failure

C.1 Tools and measuring instruments

In order to be able to manage disturbances while driving, following tools and measuring instruments should belong to the equipment on board:

- Multimeter for voltage (AC), frequency and resistance
- Measuring instrument for inductance
- Measuring instrument for capacity
- Current absorbing clamps
- Thermometer (ideal is a infrared thermometer)
- Pressure device (pincer) für coolant circuit

C.2 Overloading the Generator

Please ensure that the genset is not overloaded. Overloading occurs when the electrical load (demand) induces a load torque in the generator which is higher than that which the diesel drive motor can provide. Overloading causes the engine to run rough, burn oil, creates excessive exhaust (environmentally unfriendly) and even to stall. Extra caution should be practised with multi-power units (single and 3-phase current generation) to avoid overloading the diesel drive engine.

The generator should only be loaded at the peak rated power for short periods only! A high peak current is required to start many electrical devices, especially electric motors and compressors (from a still stand state).

In order to prolong the genset's life expectancy, the nominal electrical demand on the system should not be more than 70% of the rated genset peak load.

Keep PEAK LOADING demand in mind when switching on electrical devices (esp. fridge compressors, electric motors, battery chargers, kettles, etc.) which are fed by the generator. Careful "powering up" (gradual loading) of the electrical demand on the generator will help prolong the life of your genset! The genset can be run for several hours at partial load (i.e. 2/3 of rated power), however it is not advised that it is run for more than 2-3 hours at full load. The Panda is designed so as not to overheat even under extreme conditions. Note: The exhaust gas will become sooty during peak-load operation.

Effects of Short Circuiting and Overloading on the Generator

The generator **cannot** be damaged by short circuiting or overloading. Short circuiting and overloading suppress the magnetic excitation of the generator, thus, no current is generated and the voltage will collapse. This condition is immediately offset once the short-circuit has been eliminated and/or the electrical overload removed.

Overloading the Generator with Electric Motors

With the operation of electric motors it must be considered that these take up a multiple of their rated output as starting current (six to tenfold).

If the power of the generator for the engine is not sufficient, the voltage in the generator breaks down after switching on the engine. For special approach problems the manufacturer can give recommendations regarding the accomplishment of the situation (e.g. amplified capacitors, gradual start switch or extra developed starting unit for electric motors).

The system efficiency can be improved up to 50% and the starting current can be improved up to 100% by a professional adjustment of the engines. If the inductive load (electrical motors etc.) lies over 20% of the generator rated output a compensation is appropriate (see in addition also the writing: "Operation Instructions for Generators with Inductive Loads").

C.2.1 Monitoring the Generator Voltage

ATTENTION! - See "Safety Instructions" on Page v.

The voltage range of the power stations normally lies between 100V and 130V in the 60Hz version. In some countries even substantially larger tension deviations are being called "normally". The PANDA generators are aligned that they keep these default values during normal load.

With high load or overload it can occur that the voltage drops on 95V in the 60Hz version and partly still more deeply. That can become critical for certain devices (e.g. for electric motors, cooling compressors and possibly for electronic devices). It must be paid attention that the voltage for such consumers are sufficient. This can be supervised by a voltmeter.

The voltmeter should be always installed behind the change over switch generator/land power, so that each voltage source is shown. No further voltmeter is provided for the generator itself.

If additional consumers are switched on, the voltage must be controlled in each case at the voltmeter. Sensitive devices must be switched off so long, until the voltage exceed the critical parameter.

Under certain circumstances the generator provides overvoltage. This arises if the number of revolutions of the generator is increased. Changing the number of revolutions may be made only with a tachometer and/or a voltmeter.

If sensitive and/or valuable devices are used, which are to be protected against this risk, an automatic overvoltage protection must be mounted. (voltage control with disconnection).



C.2.2 Automatic Voltage Monitoring and Auto-Shut Down

If air conditioning units (compressors) or other such valuable equipment is installed on-board, it is recommend that an automatic voltage monitoring unit be installed to protect this equipment from possible sharp voltage drops. The voltage monitoring system shuts down the entire system (and therefore all users) by means of a circuit breaker relay as soon as the voltage falls below a set value (the monitor will also shut down the on-board grid automatically when the generator is stopped). Such a relay with contactor can be obtained from the installer or as a complete unit from your Panda dealer.

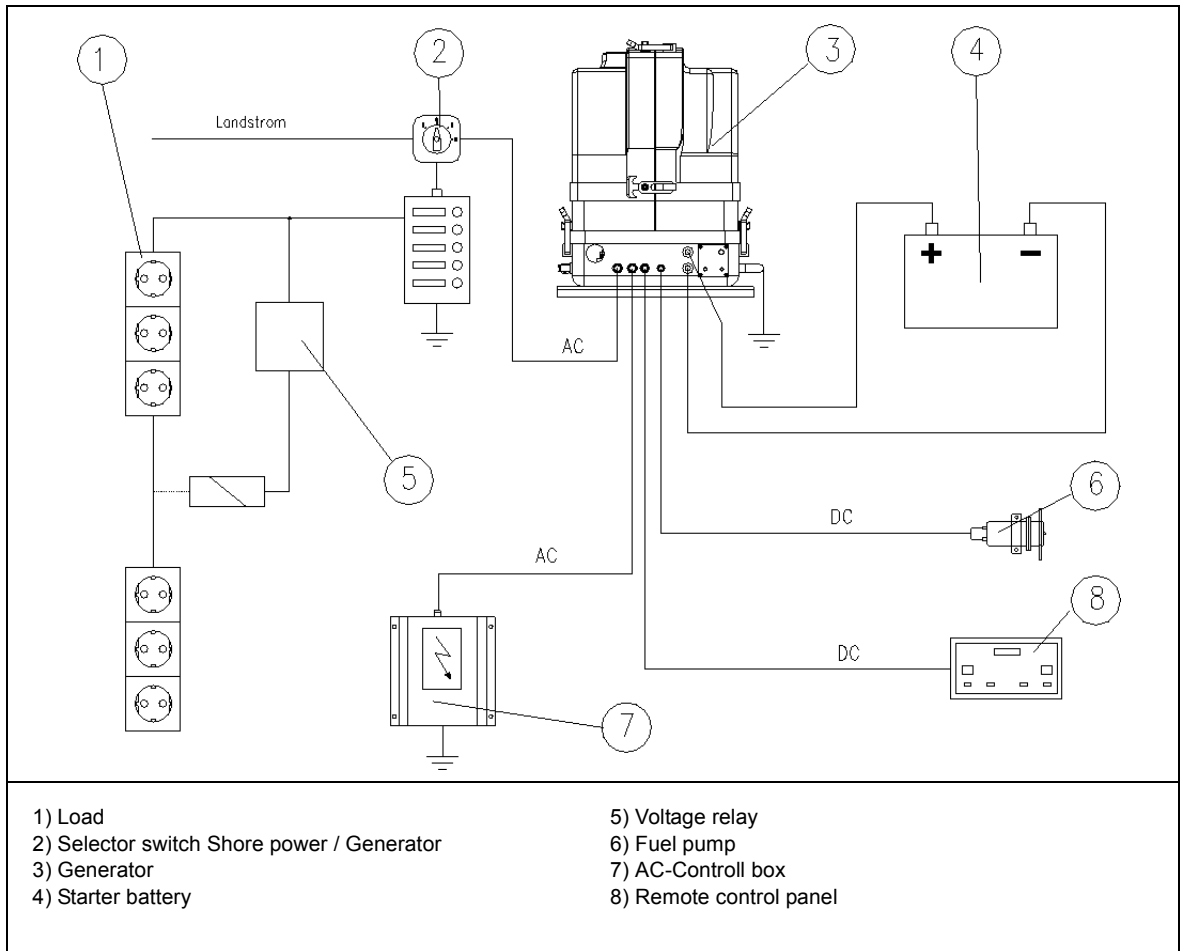

During any operation at the generator all consumers have to be switched off to avoid damages at the equipments. Also the solid state relay, which is installed in the AC-control box must be disconnected to avoid an accidentally activation of the booster capacitors.

Re-connect the connections if the electrical supply lines in the AC-control box were also be disconnected.

The generator can't be damaged by an overload because the winding is overload- and short-circuit safety. But damages are possible in the periphery. Especially connected consumers are endangered because a lower voltage can damage them by order.

Possible disturbances in the area of the rev regulation "VCS"	
Failure	Cause
Fuse on the printed circuit board of the VCS control is melted.	<ul style="list-style-type: none"> constant overload of the generator.

Steps to check the voltage control by a disturbance:

1. Check the fuse on the VCS printed circuit board.
2. Check if the sense voltage is wired to the VCS printed circuit board.
3. Check if the VCS supply voltage is wired to the VCS.
4. Check if the VCS outlet signal for the actuator is wired.

Change the VCS printed circuit board if the points above carries no clearance.

C.3 Low Generator-Output Voltage

If the produced alternating voltage is too low, switch the consumers off, in order to relieve the generator. Mostly the problem already solved. If the output voltage is still too low, even if all consumers are switched off, the generator runs without load, you can assume one or more condensers are defective.

C.3.1 Discharge the capacitors

ATTENTION! Never work at the electrical cabinet, when the generator is running! Do not contact the capacitor. Before working on the system read the section "Safety Instructions" on Page v.

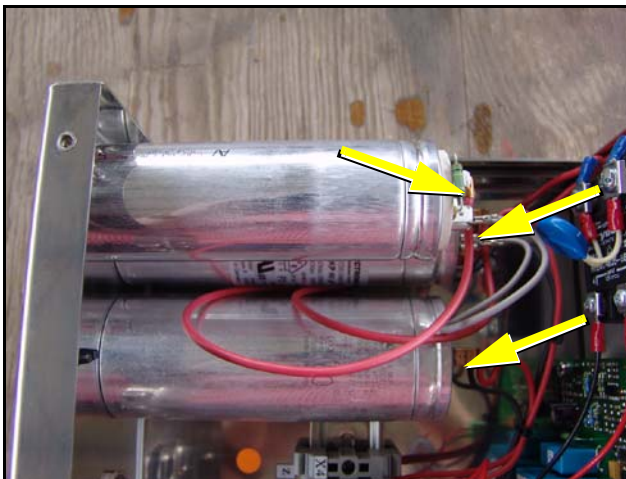

- 1) Switch off generator
- 2) Disconnect starter battery
- 3) Open AC-Control box

The capacitors are discharged, by short circuit the two contacts. In addition use the cone end of an isolated screwdriver.



C.3.2 Checking the capacitors

If the capacitors are to be checked, it is to be made certain that the capacitors will be discharged before touching.

Already a visual check can give information on whether the capacitors are defective:

- Leaks dielectric?
- did the capacitor became longer?

The capacitors can be tested with a multimeter. Switch the measuring instrument to "pass" and connect both connections of the capacitor with the connections at the measuring instrument.

Touch with the test prods the two contacts of the capacitor. By the internal battery a charge transfer in the capacitor should take place now.

If changes the poles of the capacitor with the test prods, again a short "beep" should have to be heard. This short sound is only an indication for the fact that the capacitor is not defective.



Should a steady sound or no sound have to be heard, the capacitor is defective and must be replaced.

In order to go surely that the capacitor has still its full capacity, use a capacity measuring instrument.

The capacitors, which not achieve the imprinted capacity value at this measurement, should be exchanged as fast as possible. If all capacitors are still functional, must be checked whether the connection to the strip is correct.

Checking the electrical connections to the capacitors

It must be ensured that the electrical connections to the capacitor are always tight fitting. Loose connections with transitional resistance can mean that the contact surfaces will become heated externally. This can lead to faster deterioration of the capacitors.

C.3.3 Checking the generator voltage

In order to test, whether the fixed winding produces enough voltage, proceed in such a way:

1. Guarantee that the connection to the electrical system is interrupted.
2. Remove all conductions in the power terminal box of the generator.
3. Starter battery must be connected with the generator.
4. Start the generator start.
5. Measure with a voltmeter the voltage between the phase(s) and N. If the measured values are under the substantially values in Table F.3, "Technical Data Generator," on Page VI, a coil damage is to be accepted.

During the measurement in the 60Hz version both partial coils must be interconnected, i.e. a connection must be provided between line 1 and line 3. (see wiring diagram)

(notes: the voltage results from the remainder magnetism of the rotor, which induced a voltage in the coil.)

C.3.4 Measuring the coil resistance

For this a measuring instrument must be used that is suitable for low impedance values.

- Adjust the measuring instrument to resistance test. If hold the poles of the measuring instrument hold together, 0.00 ohms should be indicated. If the poles are isolated, the display should indicate an overflow. Please implement this test, in order to examine the equipment.
- Measure of the resistance within the individual windings.

Wenn hier starke Abweichungen in den einzelnen Wicklungsteilen gemessen werden, muß man davon ausgehen, daß es in einer Wicklung einen Wicklungsschluß gibt. Auch dies führt dazu, daß der Generator sich nicht mehr erregt.

Die tatsächlichen Werte zwischen den Wicklungsteilen und Masse sind jedoch nicht so genau zu bestimmen. Es kommt in erster Linie darauf an, daß die Werte aller drei Messungen möglichst gleich sind. Abweichungen untereinander weisen auf einen Wicklungsschluß hin. In diesem Fall muß der Generator von einem Fachmann neu gewickelt werden.

C.3.5 Checking the coil(s) to short-circuit

In order to check the coils for short-circuit, first all lines, which lead to the electrical system, must be interrupted. This happens on the power terminal box of the generator or, if available, in the electrical system junction box. Guarantee that no voltage lies at the lines, before they are interrupted (see "Discharge the capacitors" on Page 30").

Now remove the bridge between "N" and "PE", so that coils and housing are electrically separate from each other.

Check with a circuit indicator (multimeter) in the power terminal box if between the individual connection points of the coil and the housing (PE) a pass exists.

The contacts which can be measured depend on the type of the generator (see identification plate):

HP1 - 60Hz: L, Z

HP3 - 60Hz:: L1, L2, L3, 1, 2, 3, 4

DVS - 60Hz : L1, L2, L3, L1', 1, 2, 3, 4

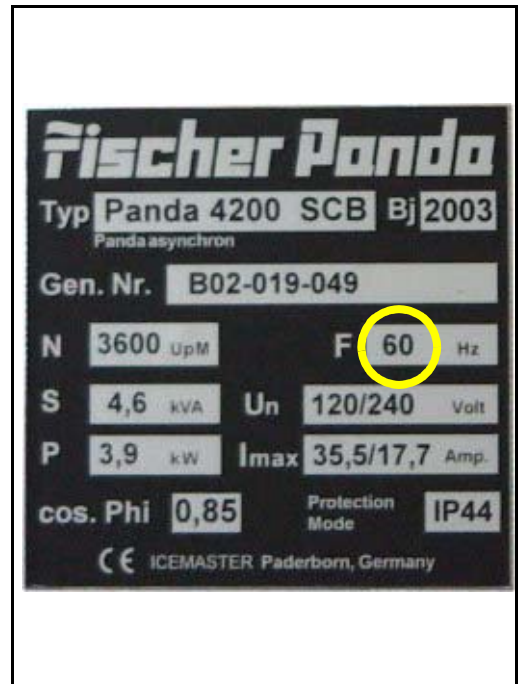

If a pass (beep) should be determined, the generator must be returned for examination in the plant, or it can also be wound again locally. For this coil datas can be requested.

C.3.6 Measuring the inductive resistance

Unfortunately the checking of the ohmic resistance permits still no reliable statement about the condition of the coil. If the ohmic resistance values arise inequalities between the coils, that is a safe indication for the fact that the coil is defective. To be exactly sure the inductive resistance of the coil have to be measured. For this a special measuring instrument is necessary, which measures the inductance of a coil.

Inductance is measured in the same way as the ohmic resistance, i.e. the coils are compared. The value is indicated in mH (milli Henry).

The arranging value for the inductive resistance can take from the Table F.3, "Technical Data Generator," on Page VI.

Note: These values depends strongly from the measuring method (kind of the measuring instrument)

C.4 Generator provides no Voltage

C.4.1 Rotor Magnetism Loss and "Re-magnetizing"

ATTENTION! See "Safety Instructions" on Page v.



With asynchronous generators it can be the fact that the generator can not build up independently voltage after longer service lives, or, if it were switched off under full load. The cause lies in the fact that the rotor lost its remainder magnetism.

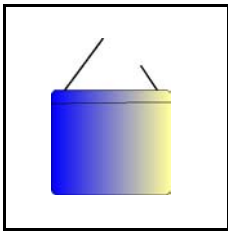

This remainder magnetism can be restored in a simple manner by a DC battery. In addition the „shore power“ must be switched off and any connection to a AC-source must be interrupted.

Likewise the aggregate must be switched off, i.e. also the starter may not be operated. The power source selector is switched to "generator". Only the plug socket must be connected with the generator.

Now the two poles of a 9V battery are connected with the plug socket or held to the appropriate contacts in the on-board current distribution. Use not a battery bank or the generator starter battery, this could damage the coil. The DC voltage may be applied only for a short time (1-2 seconds). In the coil the remainder magnetism is restored by the short current pulse, and the generator can be normally started.

C.5 Starting Problems

C.5.1 Starting with a weak Battery

The Panda can even be started with an almost completely discharged battery if the cylinder compression release switch is used. The engine can be easily rotated ("turned over") when cylinder valves are opened (i.e. in the "decompression position"). The fuel inlet solenoid valve requires however a minimum amount of battery charge to be opened.

The Farymann engine is equipped with an automatic cylinder compression release lever. The **black release knob** is mounted on the diesel motor's right side when observed from the diesel motor end) in front of the air inlet. This knob has two positions. The first position holds opens the cylinder valves open ("pressure release" position) and in this position, the engine can be rotated easily by hand. The second position is the normal operating position ("full compression" position). When starting the engine in the "pressure release" position, the starter can easily rotate the engine (even with a weak battery) and after 5 revolutions, the compression release knob switches automatically to the normal "full compression" position.

ATTENTION!

The fuel solenoid valve must be opened by an additional voltage.

Decompression lever

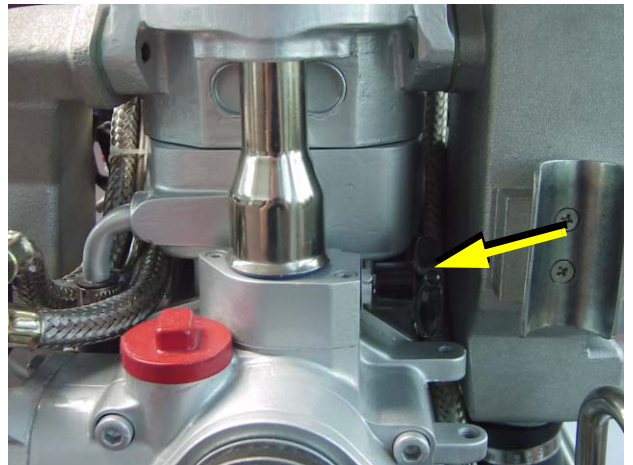

C.5.2 Fuel Solenoid Valve

The fuel solenoid valve is located in front of the injection pump. It opens automatically, if the „START“-button is pressed on remote control panel. If the generator is switched to "OFF", the solenoid valve closes. It takes some seconds, before the generator stops.

If the generator fails to start, runs rough, does not reach the proper RPM, or does not stop properly, the first item to suspect in most cases is the fuel solenoid valve and should be inspected first.

A check of the fuel solenoid valve by removing the plug from the fuel solenoid valve for a short period whilst in operation (first remove the small retention screw) and replace it immediately. The motor should "react immediately" by revving high. If the motor does not react sharply to the reconnection of the solenoid wire, it is a sign that the solenoid valve could be faulty.

1. Fuel solenoid valve
2. Ventilation screw

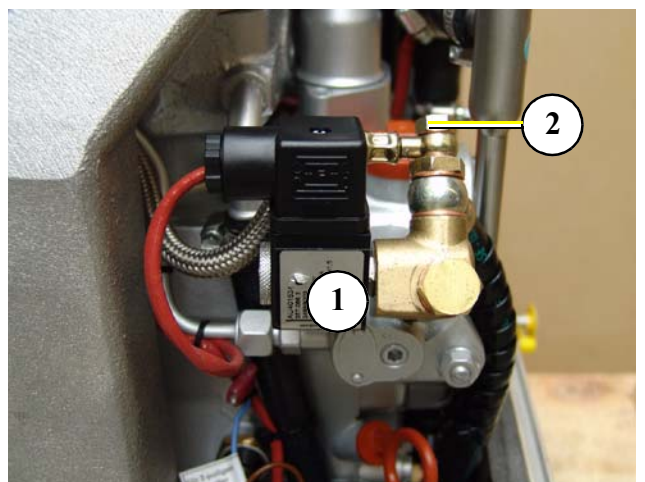

Damage to starter motor

The starter is fitted with a free wheel or axial rotating spring cog, which prevents the starter being driven externally by means of the motor. The free wheel will be heavily worn, if the starter still operates, thereby causing damage to the springs, roller bearings or cog teeth. This could lead to complete destruction of the starter.

It is important that every person who operates the generator is informed of this situation. This is practically the only handling error that can be made on board that can lead to fatal consequences for both generator and operator.

C.5.3 Troubleshooting Table

For troubleshooting see "Troubleshooting" on Page I.

D. Installation Instructions

D.1 Placement

D.1.1 Placement and Basemount

Since Panda generators have extremely compact dimensions they can be installed in tight locations, attempts are sometimes made to install them in almost inaccessible places. Please consider that even almost maintenance-free machinery must still remain accessible at least at the front (drive belt, water pump) and the service-side (actuator, dipstick). Please also note that in spite of the automatic oil-pressure sensor it is still essential that the oil level has to be checked regularly.

The generator should not be installed in the proximity of light walls, which can get into resonant vibrations by airborne sound. If this is not possible, these surfaces should line with 1mm lead foil, so the mass and the swinging behavior are changed.

Avoid to install the generator on a smooth surface with small mass (e.g. plywood plate). This affects in the unfavorable case like an amplifier the airborne sound waves. An improvement obtains by compound these surfaces by ribs. Also break-throughs should be sawed, which interrupt the surface. Disguising the surrounding walls with a heavy layer (e.g. lead) plus foam material improves the conditions additionally.

The engine draws its inlet combustion air through several holes in the capsule base. Therefore the capsule must be fitted with sufficient clearance between the capsule underside and the base plate (min. 12mm (1/2")).

The generator sucks its air from the surrounding engine room. Therefore it must be ensured that sufficient ventilation openings are present, so that the aggregate cannot overheat.

High temperature of the intake air decline the power of the aggregate and increases the coolant temperature. Air temperatures of more than 40°C reduce the power by 2% per temperature rise of 5°C. In order to keep these effects as small as possible, the temperature in the engine room should not be higher than 15°C in relation to the outside temperature.

D.1.2 Notice for optimal sound insulation

The convenient base consists of a stable framework, on which the generator is fastened by means of shock-mounts.

Since the aggregate is "free" downward, the combustion air can be sucked in unhindered.

In addition are void the vibrations, which would arise with a closed soil.

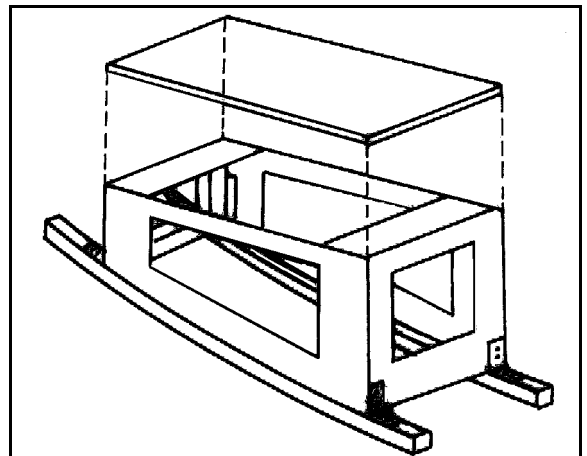

D.2 Generator Connections - Scheme

The generator comes supplied with all supply lines (i.e. electric cables, fuel lines etc.) already connected to the motor and generator. The supply lines are fed through the capsule's front base panel and are shielded at the capsule inlets with water-proof grommets.

All electrical connections, cable types and sizes must comply to the appropriate regulations. The supplied cables are rated for ambient temperatures up to 70°C (160°F). If the cables are required to meet higher temperature requirements, they must be run through conduits.

ATTENTION! Before working (installation) on the System read the section "Safety Instructions" on page v in this Manual.

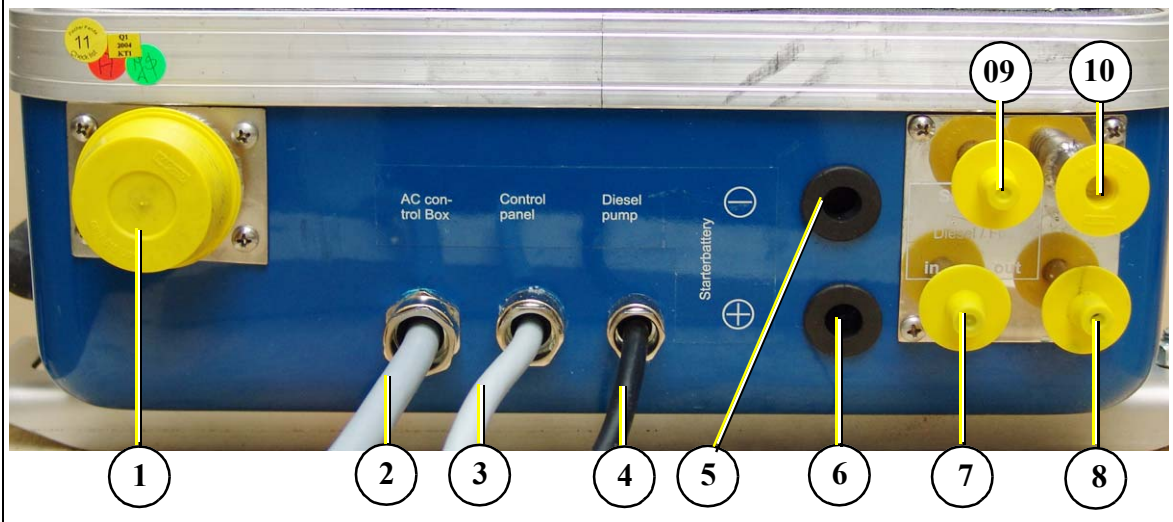

- | | |
|---|---------------------------------------|
| 1) Connection for exhaust | 6) Starter battery positive cable (+) |
| 2) Cable for AC-Control box (VCS-control) | 7) Connection fuel IN |
| 3) Cable for remote control panel | 8) Connection fuel OUT |
| 4) Cable for external fuel pump | 9) Connection external expansion tank |
| 5) Starter battery negative cable (-) | 10) Raw water intake |

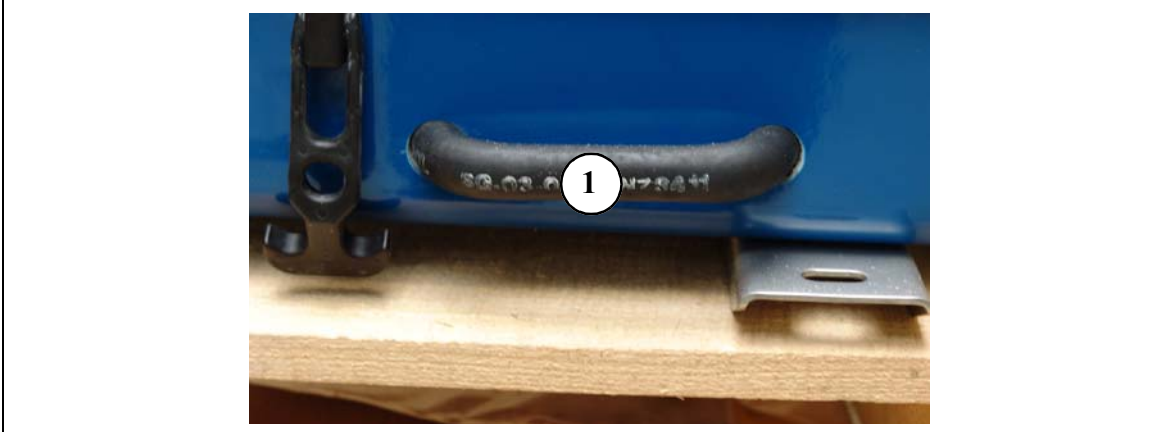

- 1) Connection for external ventilation valve



D.3 Cooling System Installation - Raw water

D.3.1 General References

The genset should have its own sea water (coolant water) inlet and should not be connected to any other engine systems. Ensure that the following installation instructions are complied with:

Avoid galvanic corrosion

For the avoidance of galvanic corrosion the chapter "Service instruction for marine aggregates (corrosion protection)" is to be considered.

D.3.2 Installation of the thru-vessel fitting in Yachts

It is good practice for yachts to use a hull inlet fitting with an integrated strainer. The thru-vessel fitting (raw water intake) is often mounted against the sailing direction to induce more water intake for cooling.

For Panda generators, the thru-vessel inlet should NOT point in the sailing direction! When sailing at higher speeds more water will be forced into the inlet than what the pump can handle and your generator will overflow!

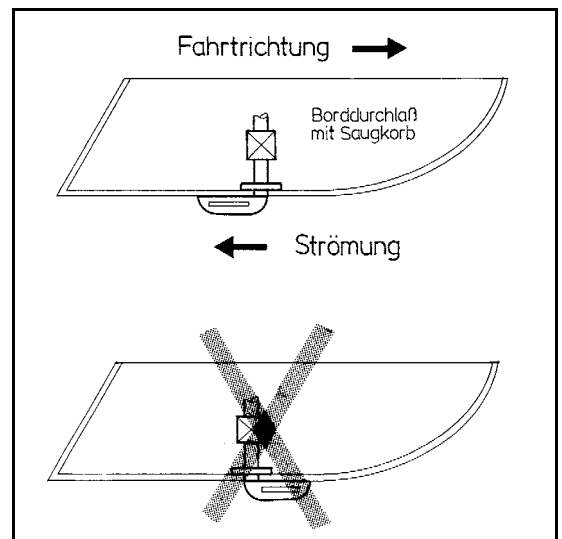

D.3.3 Quality of the raw water sucking in line

In order to keep the suction resistance in the line at a minimum, the raw water intake system (i.e. sea cock, thru-hull fitting, inlet filter, etc.) must have an inner diameter of at least 1" (25mm).

This applies also to installation components such as thru-hull fitting, sea cock, sea water filter etc.

The intake suction line should be kept as short as possible. Install the sea water inlet in close proximity to the genset.

After start-up the cooling water quantity must be measured (e.g. by catching at the exhaust). The flow rate, as well as the necessary cross section of the cooling water pipe take from Table F.3, "Technical Data Generator," on page VI.

D.3.4 Installation above waterline

The Panda is equipped with a direct drive water intake pump mounted directly on the motor. Since the intake pump is an impeller pump there are wearing parts which will likely require replacement after some time. Ensure that the genset is installed such that the intake pump can be easily accessed. If this is not possible, an external intake pump could be installed in an easily accessed location.

If the generator is installed above the waterline it is possible that the impeller wearout will be stronger. After the start the pump runs dry some seconds.

The raw water hose should describe a loop as near as possible to the raw water inlet of the generator (see picture below). With it the pump only sucks in air for a short time. The impeller will be lubricated by the raw water and its life time will rise.

By the installation of a check valve in the sea water inlet line, which is under the waterline, this problem can be limited a little .

It is very important to change the impeller every few month. When starting the generator you should pay attention and listen when raw water comes out from the exhaust. If this lasts longer than 5 seconds the impeller has to be changed, because he sucks to much air before raw water reaches the impeller and the impeller wears out strongly. In this case the impeller loses its function, which leads to an overheating of the engine.

If the impeller isn't exchanged early enough, the impeller wings can break into pieces and clog the cooling circuit. Therefore it is very important to change the impeller every few month.

NOTE:

Never change the impeller for many years, without exchanging the old pump. If the sealing ring is defective within the pump, raw water runs into the sound cover of the aggregate. A repair is then very expensive.

Replacement impeller and also a spare pump should always be on board. The old pump can be sent back to ICEMASTER, where it is then economically overhauled completely.

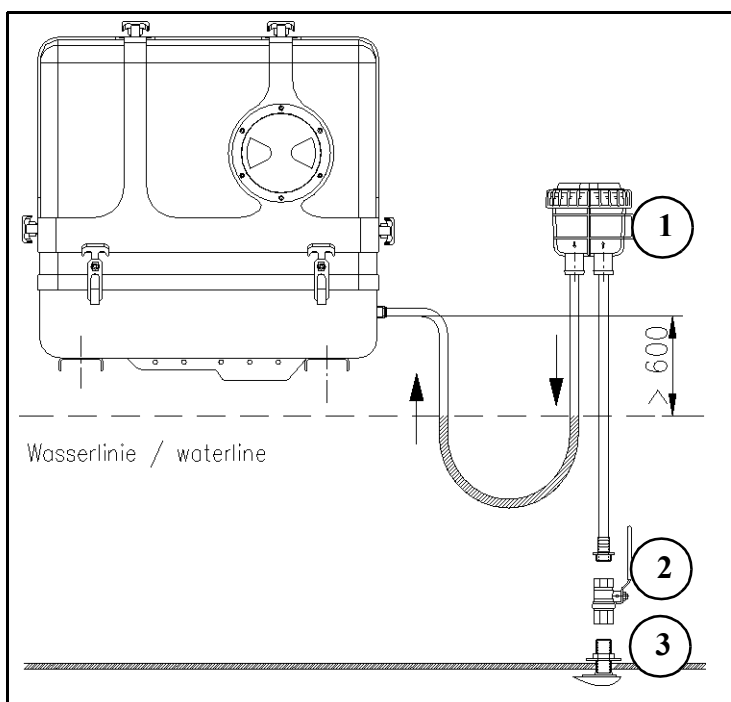

1. Raw water filter
2. Water cock
3. Hull inlet

Make certain that the raw water filter lies above the water level, otherwise with cleaning water can penetrate by the hull inlet.

An external pre-pump can relieve the impeller.

D.3.5 Installation below waterline

If the generator can not be attached at least 600mm over the waterline, a vent valve must be installed into the raw water line. With location beside the "midship line" a possible heeling must be considered! The water hose for the external vent valve at the back of the sound cover splits on the pressure side of the pump and at both ends in each case extended with a connecting nipple by a hose end. Both hose ends must be led out outside of the sound cover to one point, if possible 600mm over the waterline in the midship line. The valve is connected at the highest place with the two hose ends. If the valve is blocked, the cooling water pipe cannot be ventilated after the stop of the generator, the water column is not interrupted and the water can penetrate into the combustion chamber of the engine. This leads to the destruction of the engine!

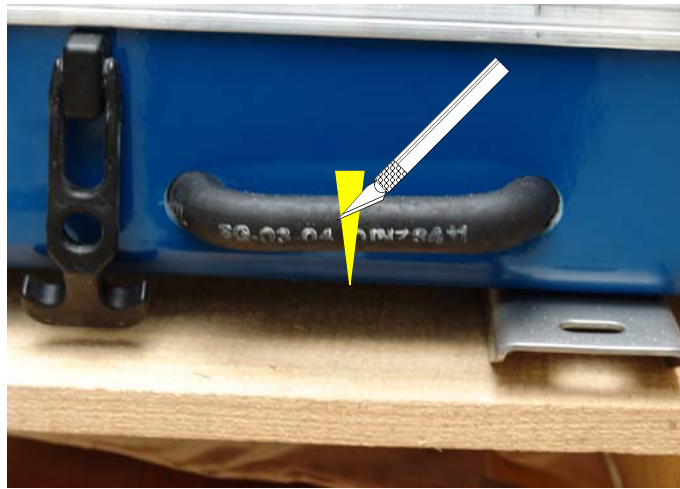

Cut the hose for the external vent valve...

...and bent it upwards.

Both hose ends must be led out outside of the sound cover to one point, if possible 600mm over the waterline in the midship line. The valve is connected at the highest place with the two hose ends.

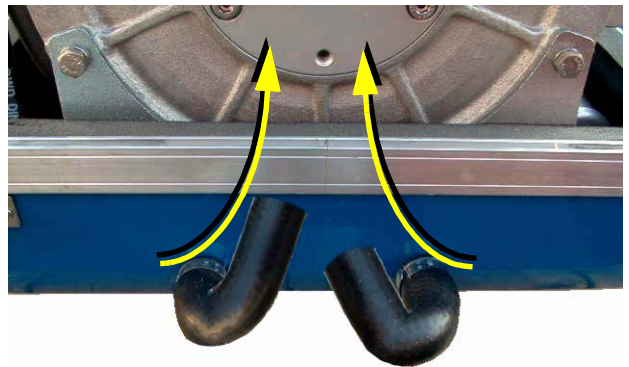

NOTE: The ventilation valve must be installed directly behind the water pump.

If the water pump stops, the valve spring provides for it, air can penetrate and thus an Syphon effect is avoided.

The ventilation valve must be controlled regularly. For this it is to be opened to clean and grease.



D.3.6 Installation under the waterline

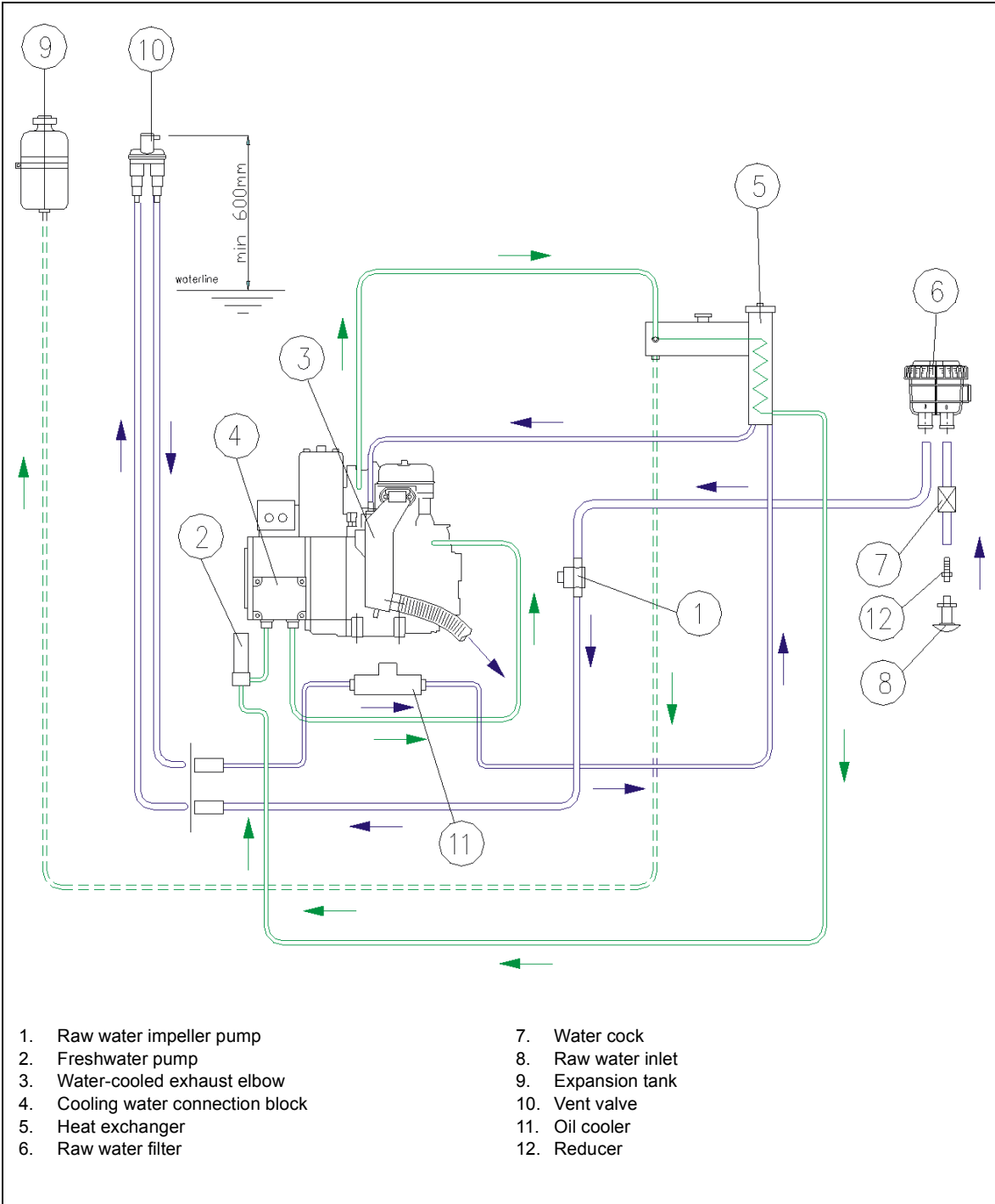

D.3.7 Installation over the waterline

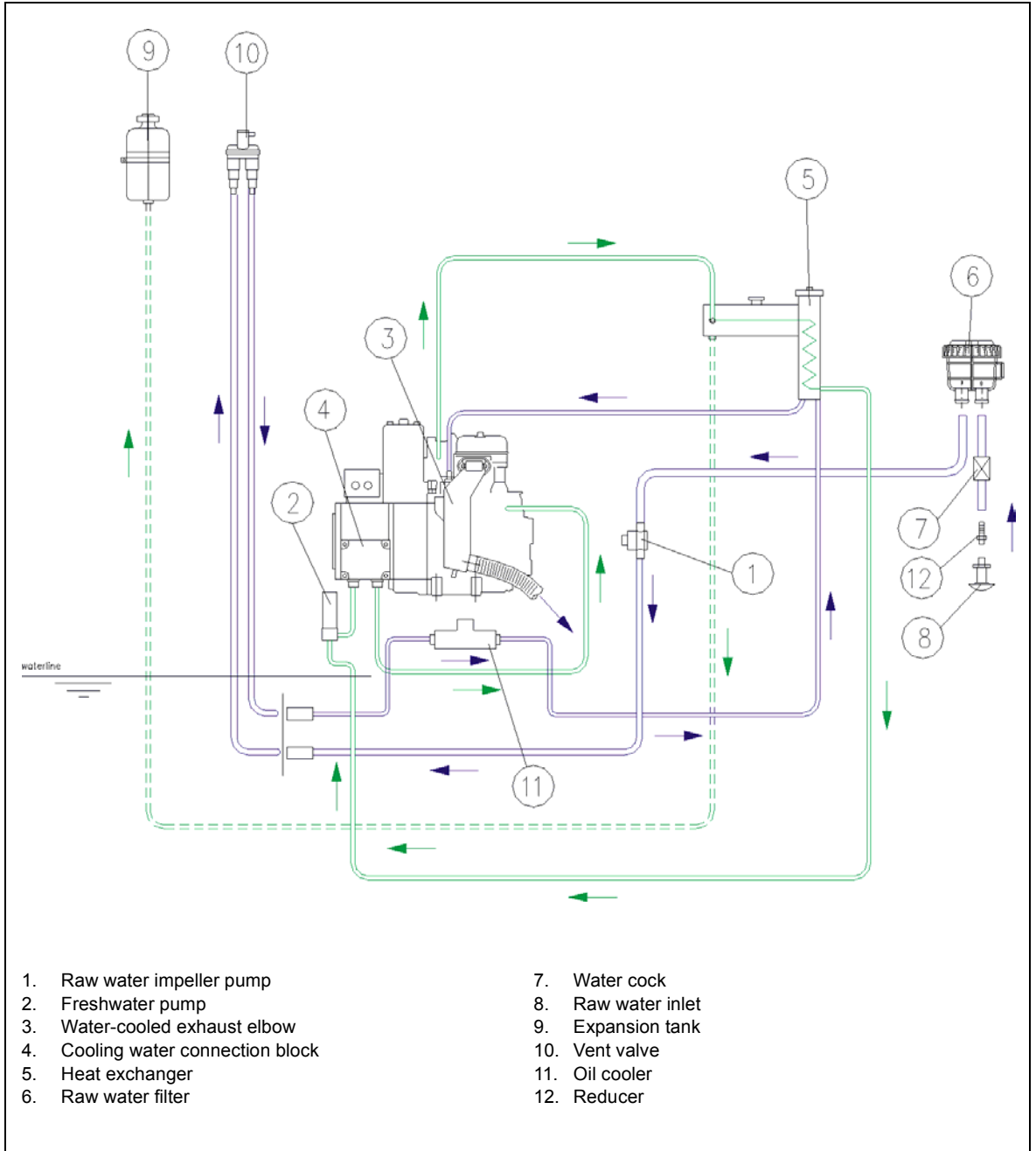

D.4 The Freshwater - Coolant Circuit

D.4.1 Position of the external Cooling Water Expansion Tank

The coolant expansion tank for the internal cooling system is to be mounted externally. The additional advantage of controlling this tank externally is achieved without having to remove the sound insulating capsule. The tank is made of a transparent material so that the coolant level is visible.

The connection between the coolant tank and the generator must be a heat-resistant rubber hose with an internal diameter of 10mm. It must be insured that the hose inclines continually upwards, when fitted, to ensure that existing air bubbles in the system can rise. The coolant tank must be mounted above the water line (the higher, the better).

Should it not be possible to place the cooling tank directly above the generator by using an upwards inclining hose because of lack of space, at least during running operation, i.e. while filling the generator. Experienced fitters therefore suspend the water compensation tank with an upwards inclining hose at least one meter above the generator, so that it can be placed in its final point of destination later.

D.4.2 Scheme for fresh water circuit

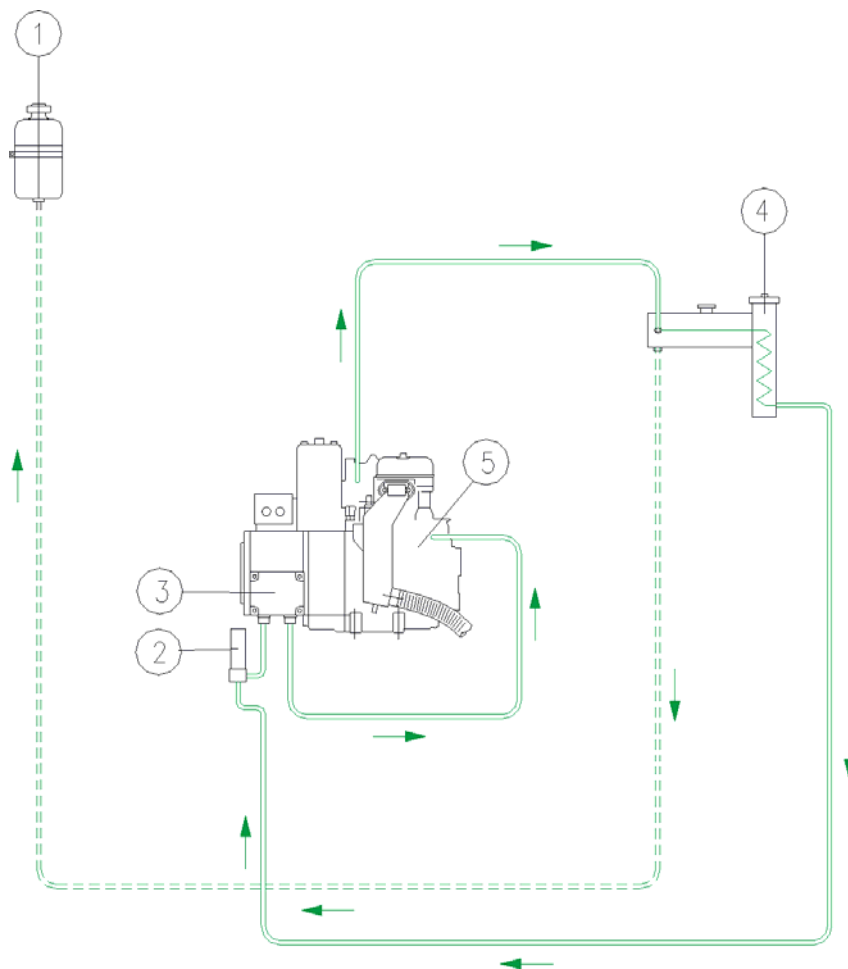

- 1. Cooling water expansion tank
- 2. Fresh water pump
- 3. Coolant connection block

- 4. Heat exchanger
- 5. Engine Farymann

D.4.3 De-aerating at the first filling of the internal cooling water circuit

Open the cooling water filler screw.

The first filling of the cooling system is made by the filler plug on the heat exchanger. The cooling system is filled before the distribution normally with coolant. The customer must make sure before start-up that the cooling system is completely filled.



Open the screw and examine whether the liquid stand up to the container upper edge. If this should not be the case, refill coolant (cooling water with freeze protection additive according to the intended mixture) and close the screw. Afterwards the cooling water catch must be screwed on firmly. Likewise the vent screws at the heat exchanger and at the exit of the electrical cooling water pump must be closed.

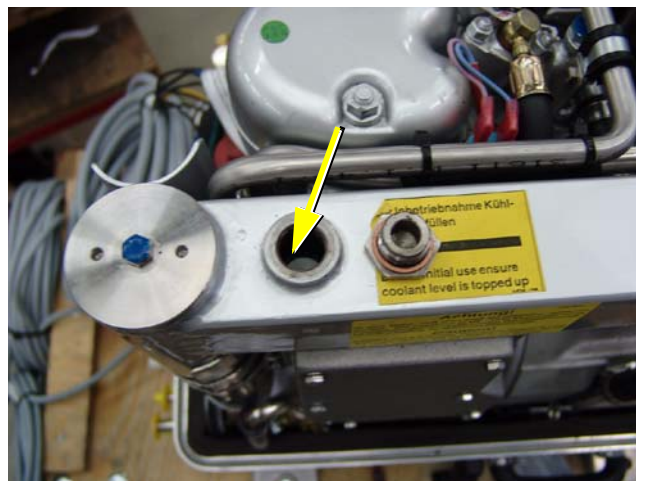

Ventilation screw at the cooling water pipe.

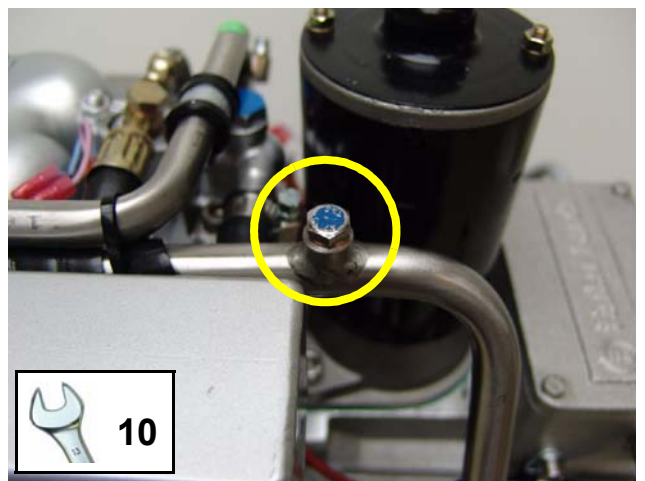

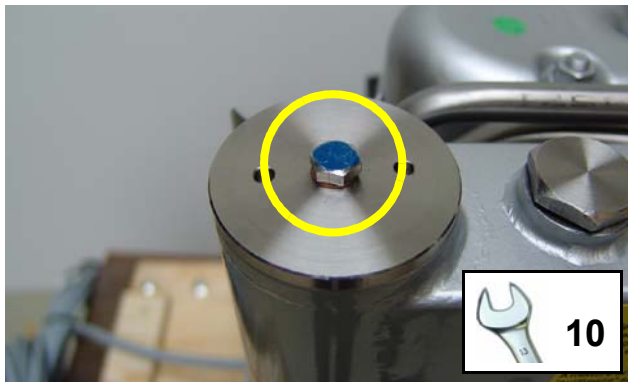

'Ventilation screw on the heat exchanger.

D.4.4 Filling and de-aerating of the internal cooling water circuit



Fill up the external cooling water expansion tank with cooling water

Note: "consider maximum level" according to marking! The cover on the external cooling water container must remain provisionally opened (all other catches are however now closed!).

Start of the generator

After filling the generator must be started. During this first phase of start-up, the generator may not be loaded. Switch the

generator off after maximally 2 minutes of period of operation again!

Note!

The external cooling water expansion tank may be filled in the maximum filling in the cold condition only up to the "max" - marking.



First de-aerating

The cooling water circuit of the generator must be de-aerated now by multiple repeating of the de-aerating procedure. During the entire procedure the external cooling water expansion tank remains opened (i.e. the cap must be removed).

After the first stopping of the the generator wait about one minute until the air in the cooling water can be drop off and raise to the highest point (ventilation point).

Now open all three ventilation points one after another as long as cooling water exit. Then the closure screw must be closed immediately. (Turn on only lightly to treat the thread.)

Pay attention that the external cooling water expansion tank is filled with enough cooling water during the de-aerating. (If necessary refill over and over.)

One de-aerating step will be last as a rule max. 2 minutes and following steps contained:

1. The generator runs approx. 1 minute.
2. Stop the generator.
3. Hold on one minute for drop of air.
4. The collected air is led out over the two de-aeration points.

The ahead described de-aerating process must be repeated as long as after the stopping and drop off air none air exit out of the de-aerating ports, only cooling water.

Anti-freeze

In the interest of safety, the freezing point of the closed circuit coolant should be **checked on regular basis**. Be sure that the coolant/antifreeze mixture is good for at least -15°C (5°F) and if is possible that your genset experiences lower temperatures, for example during storage or transportation, then the entire cooling system should be drained and purged. To purge the cooling system, compressed air at about 0.5 bar (7.5 psi) is sufficient.

Again de-aerating process in the few days after the first startup

Also after the first implementing a small amount of air can be reside in the cooling circuit. To ensure an immaculate und actual operating of the cooling system the de-aerating process must be repeated casual in the next few days (if necessary weeks). Small amount of air will be still exit out of the de-aerating openings especially if the generator stood still for a long time.



ATTENTION! During the de-aerating process it must be checked again and again if the cooling water is indeed circulating. If air bubbles established in the internal cooling water pump, it could be, that the cooling water circuit is not circulate. Then the generator would be warming very fast and switched off by overheating.

D.4.5 Pressure test for control of cooling water circuit

Check with the hand if a temperature difference exists whether between cooling water in-flow and cooling water return.

Feel the cooling water in-flow line at the internal cooling water pump.

Feel the cooling water return pipe either at the outlet of the water-cooled exhaust elbow union or at the side, where this pipe entry at the heat exchanger.

The temperature difference between in-flow and return is approx 10 degrees.

D.5 Watercooled Exhaust System

By injecting the outlet seawater into the exhaust manifold, the exhaust gases are cooled and the noise emissions from the exhaust system are reduced.

D.5.1 Installation of the standard exhaust system

The generator exhaust system must remain completely independent and separate from the exhaust system of any other unit(s) on board. The exhaust hose has an inner diameter of 30mm. The water lock must be installed at the lowest point of the exhaust system. An optional noise insulated water lock can also be installed. The exhaust hose descends from the capsule to the water lock. Then the hose rises via the "goose neck" to the silencer (see drawing). The goose neck must be vertical and sit preferably along the ship's keel centre line. The exhaust system must be installed so that the back pressure inside the exhaust does not exceed 0.4 bar (6 psi) and total length does not exceed 6m (20 ft.).

Exhaust diameter see *Table F.3, "Technical Data Generator,"* on page VI.

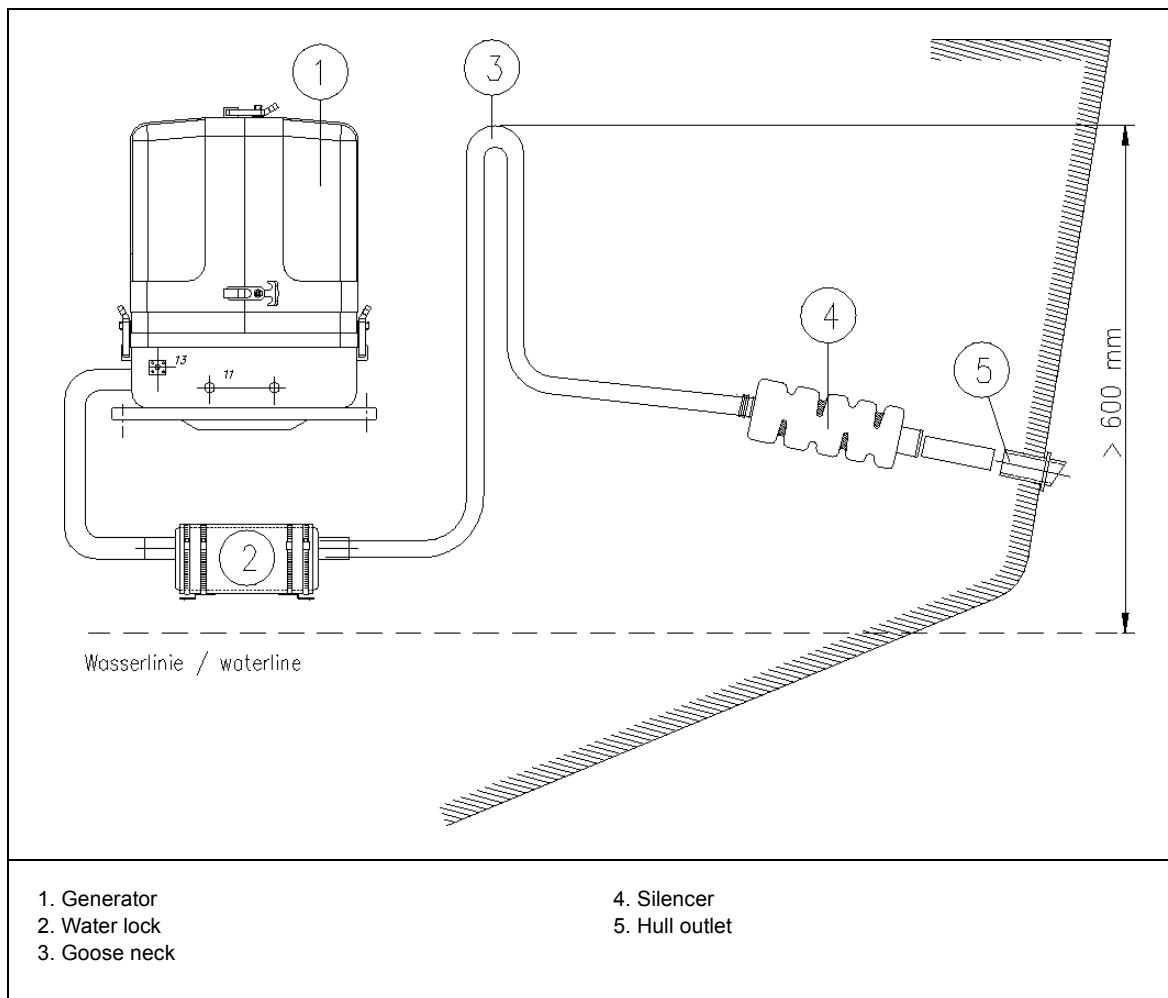

D.5.2 Exhaust / water separator

The exhaust/water separator

In order to reduce the noise level of the generator unit to a minimum, an optional exhaust outlet muffler mounted next to the thru-hull fitting can be installed. Additionally there is component at ICEMASTER, which exercise both functions of a "exhaust goose neck", and the water separation. With this "exhaust/water separator" the cooling water is derived over a separate pipe. Thereby the exhaust noises at the exterior of the yacht are strongly decreased. Particularly the "water splash" allocate.

The water flow on the exhaust/water separator unit has an inner diameter (ID) of 30mm. If the path from the water separator to the sea water outlet is very short, the hose can be further reduced to 1" (25mm) ID.

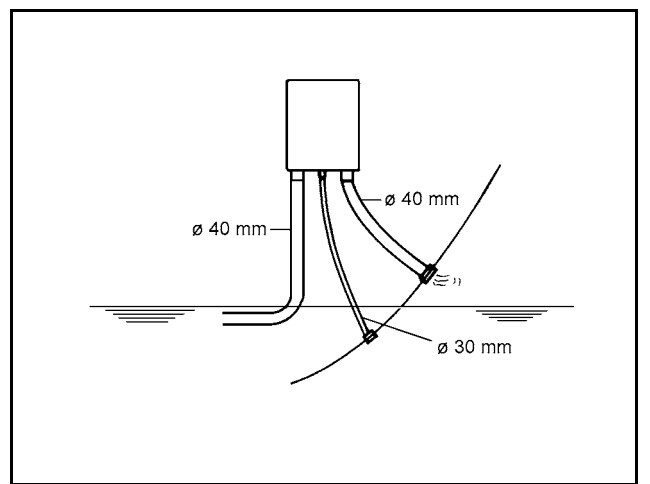

1. Raw water outlet ø 30mm
2. Hose connector ø 30mm
3. Reducer 30/20mm (if required)
4. Hose
5. Hose connector
6. Sea cock
7. Hull outlet
8. Hose clips

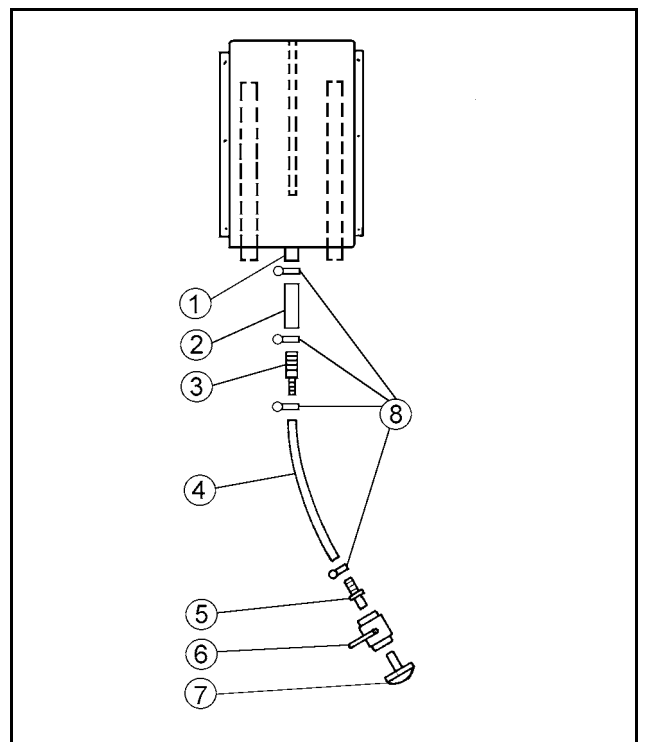

D.5.3 Installation exhaust/water separator

If the exhaust/water separator was sufficiently highly installed, a goose neck is no longer necessary. The exhaust/water separator fulfills the same function. If the "Supersilent" exhaust system were installed correctly, the generator will not disturb your boat neighbour. The exhaust noise should be nearly inaudible. The best result is reached, if the hose line, which derive the cooling water, is relocate on a short way "falling" directly to the outlet and this outlet is under the water-line.

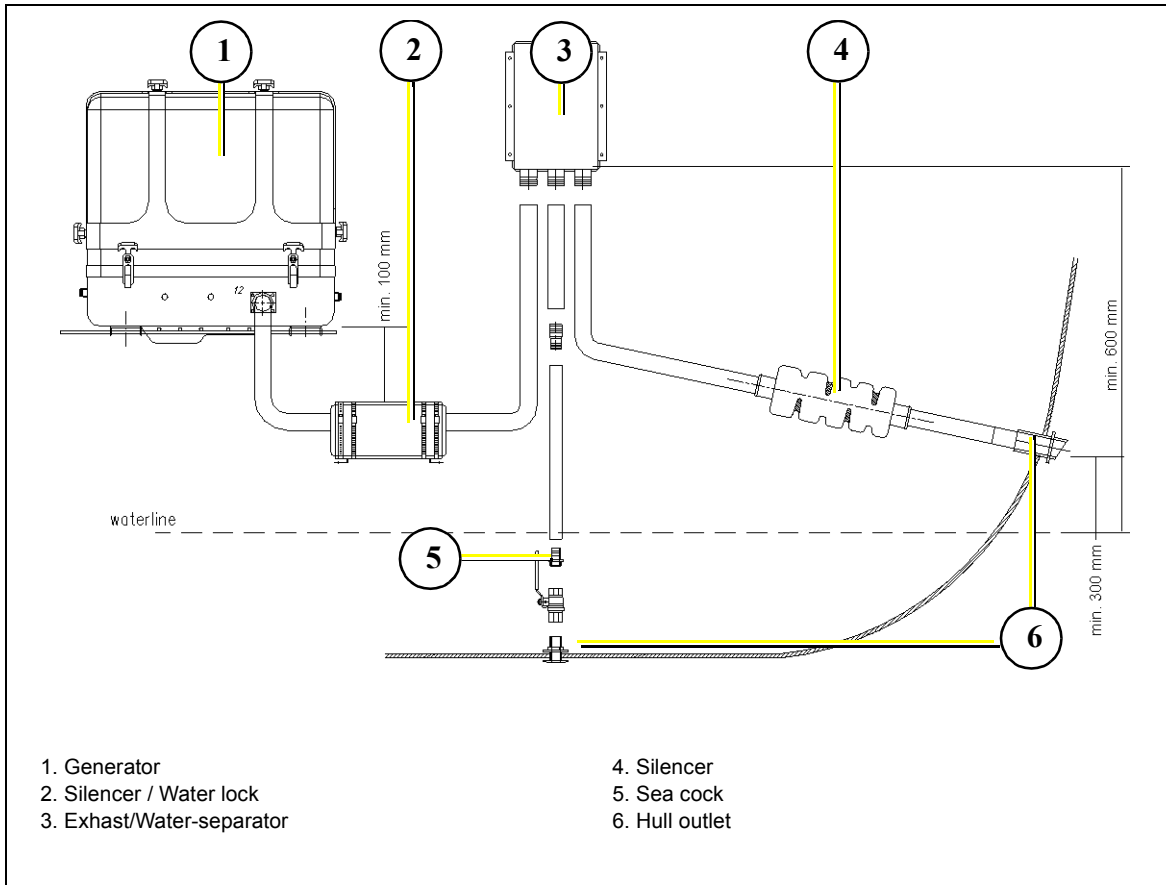

If the thru-hull exhaust outlet has to be mounted far from the generator, an exhaust-water separator must definitely be installed. The sea water from the separator must then run along the shortest possible path is the thru-hull outlet. For such long exhaust routes, the exhaust hose diameter should also be increased from NW40mm to NW50mm in order to reduce the back-pressure. The exhaust may have a length of over 10m (32 ft.) if the exhaust hose diameter is increased to 50mm. An additional outlet exhaust muffler close to the hull outlet will help further to reduce noise emissions.

An unfavorable installation:

- water lock not deeply enough under the hights level of the generator
- distance water lock to exhaust/water separator too largely

D.6 Fuel System Installation

D.6.1 General References

Inside the generator capsule itself, there is the fuel filter installed (Exception Panda 4200 and 4500). Additional fuel filters (with water separator) must be mounted outside the capsule in easily accessible places in the fuel lines between the tank intake fuel pump and the diesel motor's fuel pump.

Generally forward and return fuel flow pipes must be mounted to the diesel tanks. Do not connect the generator fuel supply lines with any other fuel lines of other diesel systems.

The following items need to be installed:

- Fuel supply pump (12V-DC)
- Pre-filter with water separator (not part of the delivery)
- Fine particle fuel filter
- Return fuel line to fuel tank (unpressurized)

The fuel supply pump should be mounted as close to the fuel tank as possible. The electric cable for the fuel pump is already installed on the generator (length 5m).

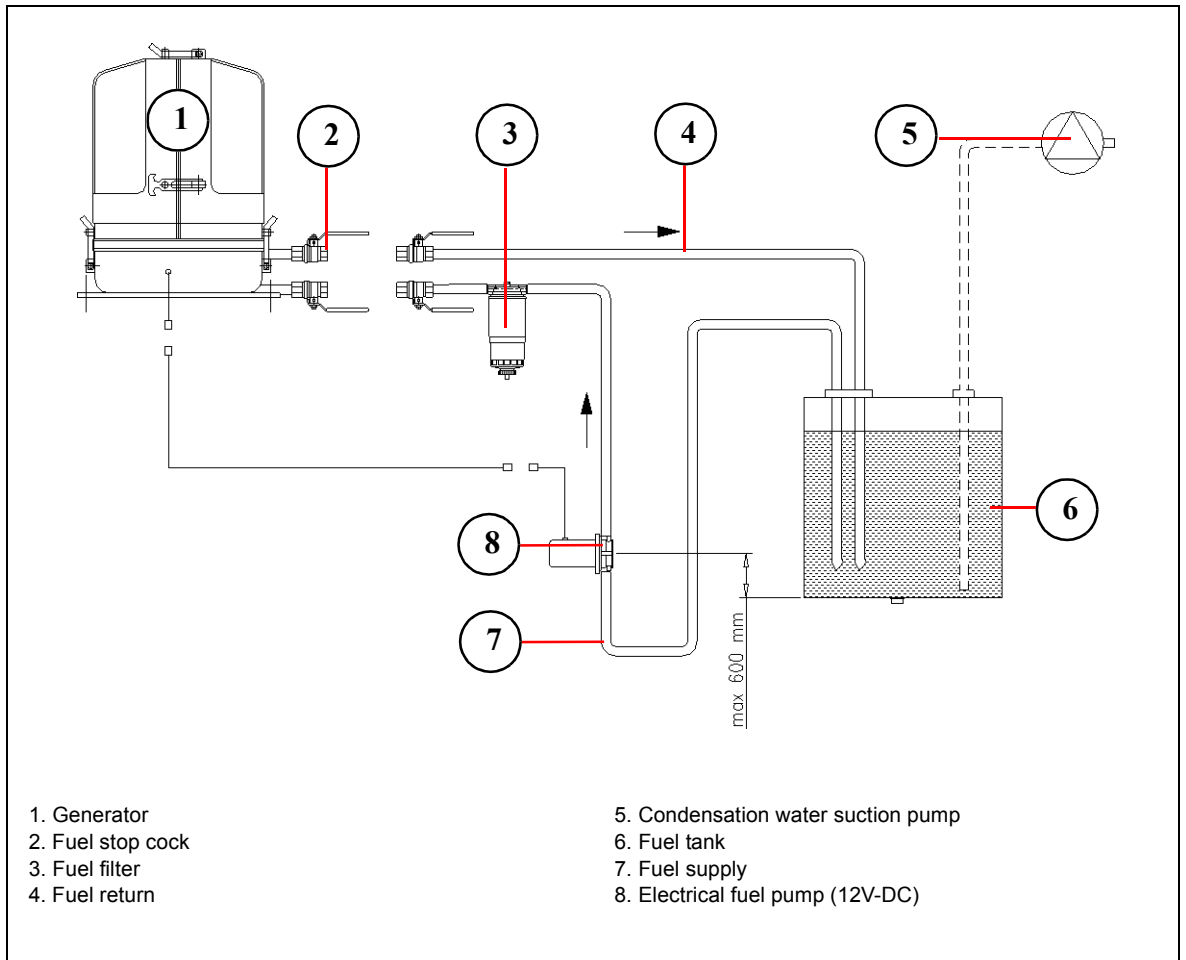

D.6.2 The electrical fuel pump

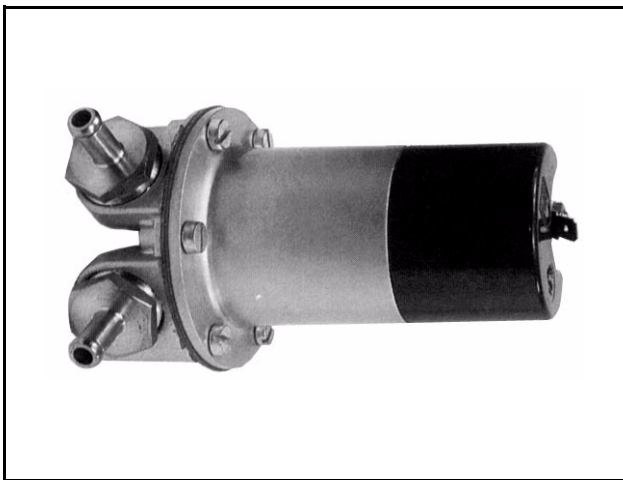

Electrical fuel pump

With the Panda generator is usually supplied an external, electrical fuel pump (12V DC). The fuel pump must be installed close at the fuel tank. The electrical connections are preloaded at the generator with the lead planned.

- Suction height of the pump: max. 1,2m at 02, bar
- Diameter of fuel lines: Table F.3, "Technical Data Generator," on page VI.

D.6.3 Connection of the fuel lines at the tank

Lead the return fuel pipe connected to the day tank to the floor

The return pipe connected to the tank must be dropped to the same depth as the suction pipe, the generator is mounted higher than the tank, in order to prevent fuel running back into the tank after the motor has been switched off, which can lead to enormous problems if the generator switched off for a long period.

Non-return Valve in the Suction Pipe

A non-return valve must be fitted to the suction pipe, which prevents the fuel flowing back after the generator has been switched off, if it is not possible to use the return flow pipe as a submerge pipe by placing it in the tank. The instructions Table B.3.1, "De-aerating the fuel system," on page 16 must be read after initial operation or after it has stood still for a long period.

ATTENTION! Non-return valve for the fuel return pipe

If the fuel tank should be installed over the level of the generator (e.g. daily tank), then non-return valve must be installed into the fuel return pipe to guaranteed that through the return pipe no fuel is led into the injection pump.



D.6.4 Position of the pre-filter with water separator

Additionally to the standard fine filter a pre-filter with water separator must be installed outside of the sound cover in the fuel system line. (is not included in delivery.)



D.6.5 De-aerating the fuel system

Normally, the fuel system is designed to bleed out air itself i.e. as soon as the electric starter motor starts operation the fuel pump starts working and the fuel system will be de-aerated after some time automatically. It is nevertheless essential to bleed the system as follows prior to the first operation (as all hoses are empty):

1. Main power switch "OFF".
2. Disconnect clamp no. 5 of the DC-terminal block.
3. Main power switch "ON" for approx.. 5 minutes (the electrical fuel pump propels and airs out automatically the fuel inlets).

Do not press the "START"-button!

4. Main power switch "OFF".
5. Reconnect lamp no. 5 of the DC-terminal block.

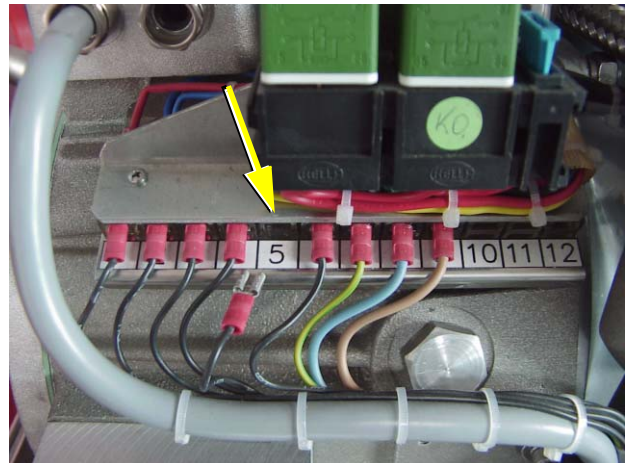

If still bubbles are in the fuel inlets, the ventilation screw at the fuel solenoid valve (or the union nut at the injection line at the cylinder head) should be opened and the procedure has to be accomplished again. It is advisable to hold an absorbent paper or cloth under the screw so that the fuel does not run in the sound cover. The fuel pump must run only until nonporously fuel withdraws. As soon as the system is aired out, the open screw must be tightened again.

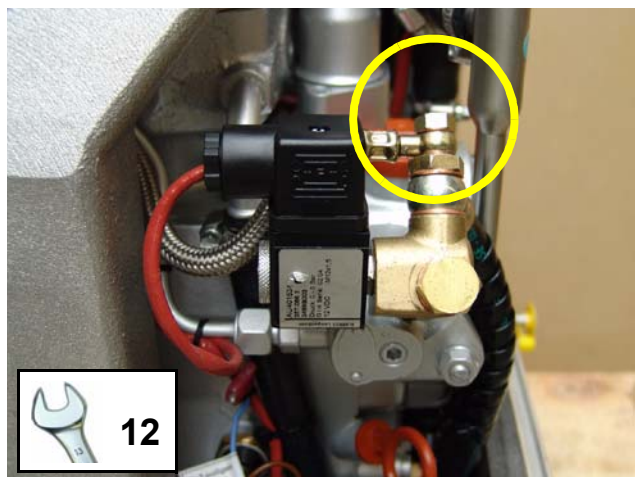

D.7 Generator 12V DC System-Installation

The Panda 4500 needs a battery with a capacity of at least 44Ah for the start. The generator can be attached to the existing starting battery of the main engine or be supplied with its own battery.

The Panda 4500 is not equipped with its own 12V battery loading installation. Thus that the starting battery is charged during the generator operation, at the exit of the generator a battery charger is ensured is normally attached. This battery charger should be selected in such a way that the rated output approx. 10% of battery capacity correspond. (120Ah starting battery requires a battery charger with approx. 10 - 12A charging current).

In the Panda accessories program special battery chargers are available, which are designed to load in connection with the generator particularly effectively. This is however necessary only if the electrical system is to be loaded hereby. For loading the generator and/or starting battery a simple, low-priced battery charger is sufficient.

D.7.1 Connection of the 12V starter battery



The positive (+) battery cable is connected directly to the solenoid switch of the starter.

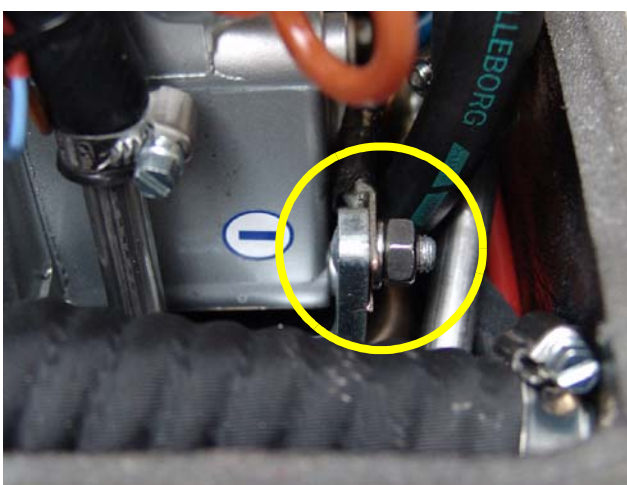

The negative (-) battery cable is connected to the engine foot.

Note! - the battery negative pole may not be connected with the boat ground or with the protective grounding of the 120V - installation!

Otherwise the danger exists with bad contact at the battery minus the terminal box burns out.

The Panda generators 4500 SCB/FCB are equipped with two various DC-relays and one electrical fuse, which can be found at the terminal strip. The various relays and fuse have the following tasks (also see the DC circuit diagram):

1. Starter relay K1
2. Fuel pump start relay K3
3. Electrical fuse (25A)

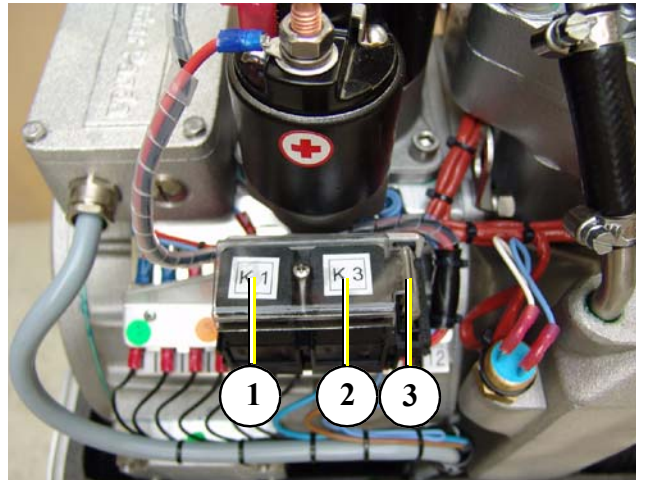

All Panda generators are equipped with an independent 12V-DC starter motor. The connecting lines cross-section from the battery to the DC system should measure 25mm².

1. Solenoid switch for starter motor
2. Starter motor

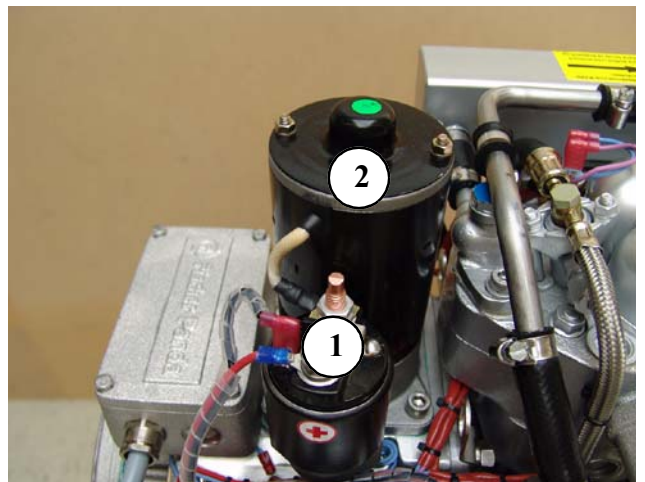

D.7.2 Connection of the remote control panel

As standard a 7 core connection-cable, 7m long, is included in the supply. Cores are numbered from 1 to 7. The control cables are securely connected to the gen-set. On the back of the control panel there are terminals numbered from 1 - 7. Connect the cores of the control-cable in respective order.

Please ensure that the remote control panel is installed in a protected, dry and easily accessible place.

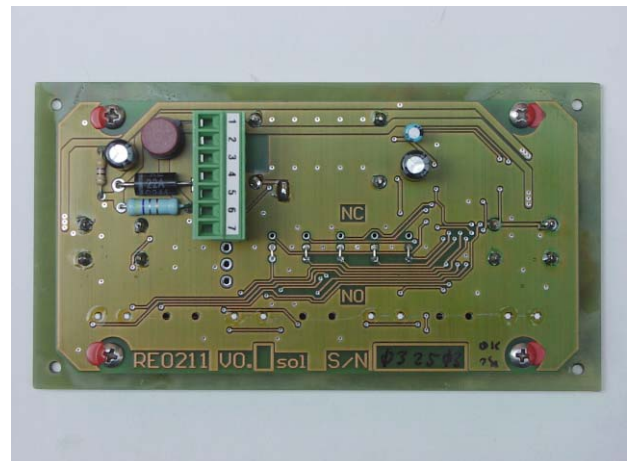

D.7.3 The speed sensor

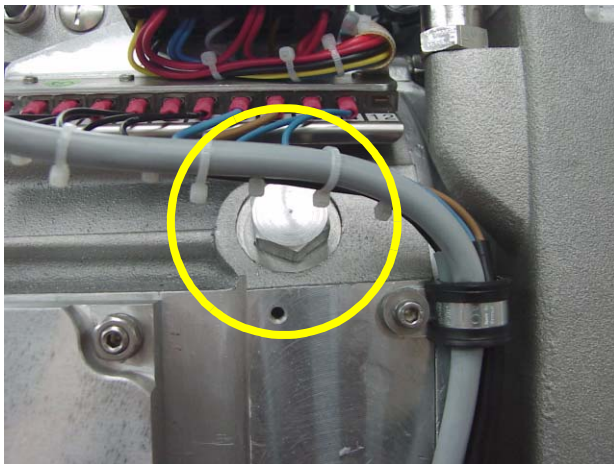

Speed sensor

Installation of the speed sensor

The speed sensor tip must have between 0.3 to 0.8mm of clearance (air gap) from the gear tooth tips. In order to achieve this clearance: the speed sensor tip should be aligned with the tip of a gear tooth and screwed in until it touches the tip of the tooth. (**ATTENTION! Ensure that when inserting the sensor, that the sensor tip is not screwed into the root of the gear tooth**). The screw is subsequently turned anticlockwise by half a turn (0.3 to 0.8mm) and held by a counter nut.

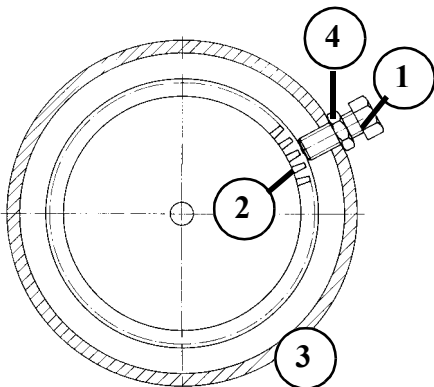

1. Speed sensor on threaded seat
2. Engine Flywheel (with gear teeth)
3. Generator housing
4. Retention/tightening nut

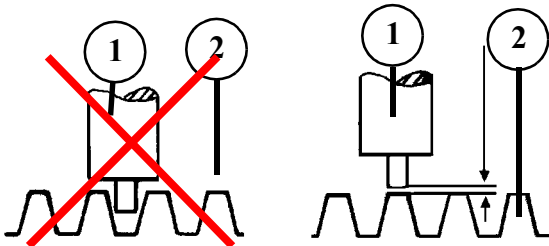

1. Speed sensor on threaded seat
2. Engine Flywheel (with gear teeth)

D.7.4 Electronic starter control unit

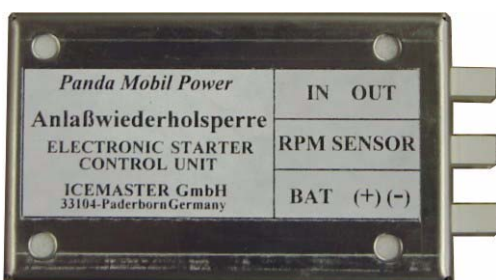

If there is an automatic starting requirement and if the remote control panel is switched off, then this automatic starting requirement is ignored. Automatic starting is only possible if after switching on of the remote control panel the automatic starting requirement takes place.

D.8 Generator AC System-Installation



ATTENTION! Before the electrical system is installed, READ the “Safety Instructions” on page v of this manual FIRST! Be sure that all electrical installations (including all safety systems) comply with all required regulations of the regional authorities. This includes lightning conductor, personal protection switch etc.

D.8.1 Installation with looped in AC-Control box

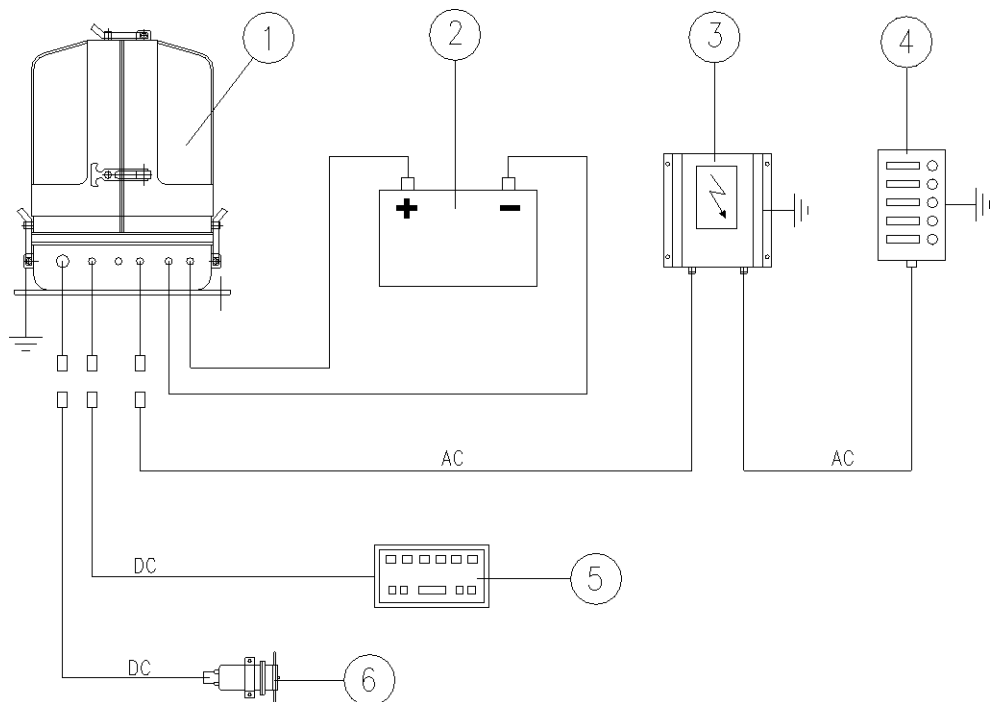

- 1. Generator
- 2. Starter battery
- 3. AC-Control box

- 4. Distribution panel
- 5. Remote control panel
- 6. Fuel pump

All electrical safety installations have to be made on board.

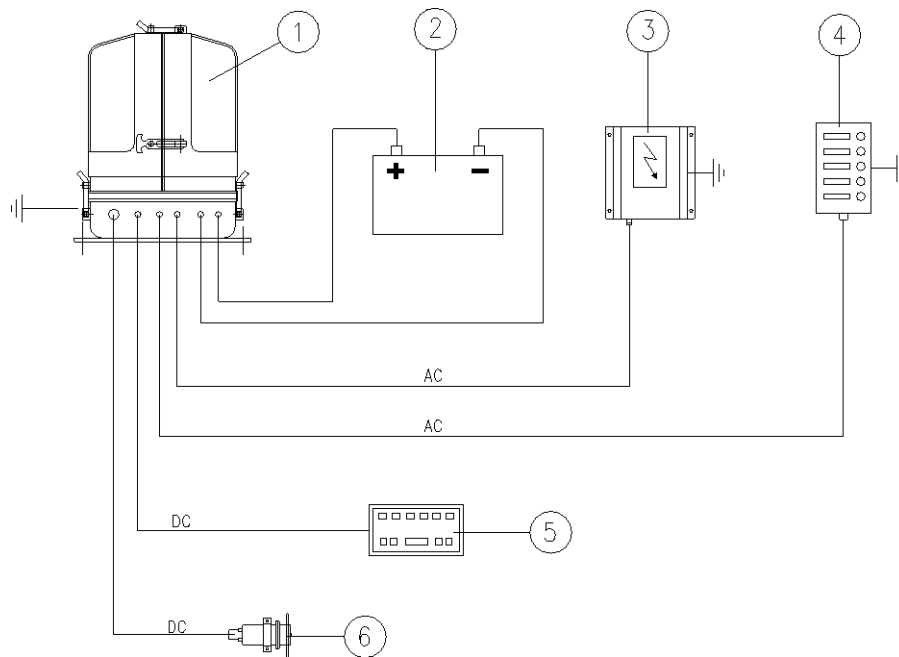
D.8.2 Installation AC-Box / distribution panel separate connected

- 1. Generator
- 2. Starter battery
- 3. AC-Control box

- 4. Distribution box
- 5. Remote control panel
- 6. Fuel pump

All electrical safety installations have to be made on board.

A power source selector switch must be installed between the generator (or if applicable, AC-Control box) and the ship's electrical supply system. This switch must be used to ensure that all AC consumers can be switched off at once. This switch should also be installed to keep the generator and shore (grid) power systems separate.

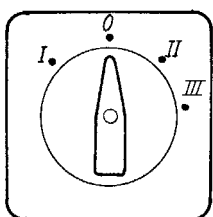

A 3-way cam-type switch should be used. This switch basic positions: "Shore power" - "OFF" - "Generator". If an (DC-AC) inverter is used, a fourth position will be required.

- 0. OFF
- I. Generator
- II. Shore power connection
- III. Inverter

The cam-type switch must have **2 poles**, so that "MP" and "phase" can be switched off.

If a 3-phase current system is also installed with the option of supplying from either the generator or shore power, an **additional** switch must be installed to keep these systems separate.

An alternative to a manual rotating switch is an automatic power relay. When the generator is not running, the relay remains in the shore power position. As soon as the generator is running, the power relay switches automatically to the generator position.

If the system has both single and 3-phase AC, it is CRITICAL that the two systems remain SEPARATE!

Electrical fuses

It is absolutely essential that the electrical system installation is inspected by a qualified electrical technician. The generator should have its own AC **input electrical fuses**. The fuses should be sized such that the rated current of the generator on each of the individual phases is not exceeded by more than 25%.

The fuses must be of the slow type. A 3-way motor protection switch must be installed to protect the electrical motor.

Required cable cross-sections

The following recommended electrical cable dimensions (cross sections) are the minimum required sizes for a safe installation. (see Table F.3, "Technical Data Generator," on page VI.

D.8.3 AC-Control box with VCS and ASB

In the AC-Control box the needed capacitors for the excitation of the generator are placed as well as the electronic control for voltage/speed regulation VCS and the starting current reinforcement ASB. The AC-Control box must be connected with the conductions (high voltage and low-voltage) to the generator.

The front panel must always be closed, since the AC-Control box produces 400V during operation.

Danger - High voltage

ATTENTION! Before working on the System read the section "Safety Instructions" on page v in this Manual.

ATTENTION! Never touch the terminals of the Solid State Relays, capacitors or booster electronic! HIGH VOLTAGE! DANGER OF LIFE!



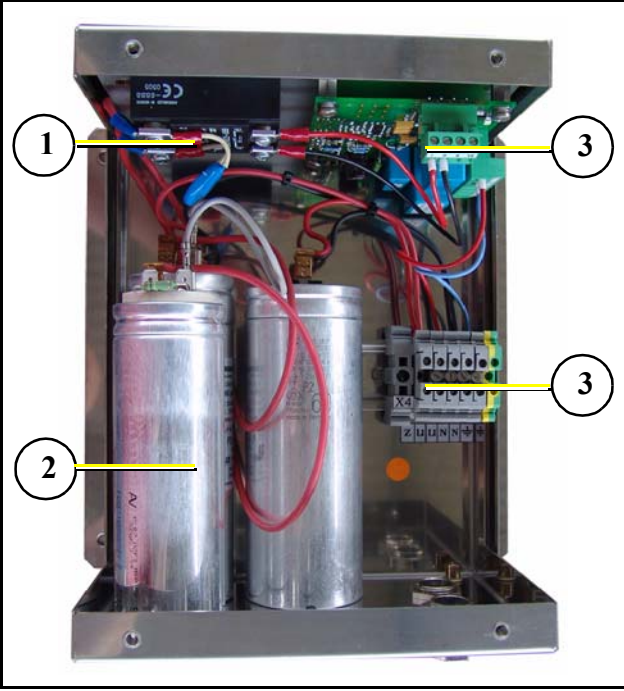

1. Solid state relay for booster capacitor
2. Capacitors for excitation and booster
3. Booster electronic RE 0502
4. Terminal block X4

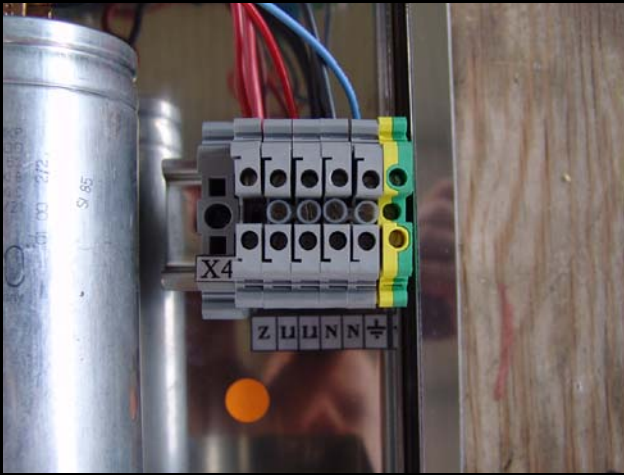

Terminal block X4

D.8.4 Booster electronic

The booster electronic regulates the electrical voltage of the generator. It includes the number of revolutions of the engine.

All control signals are processed on the measuring plate in the AC-Control box.

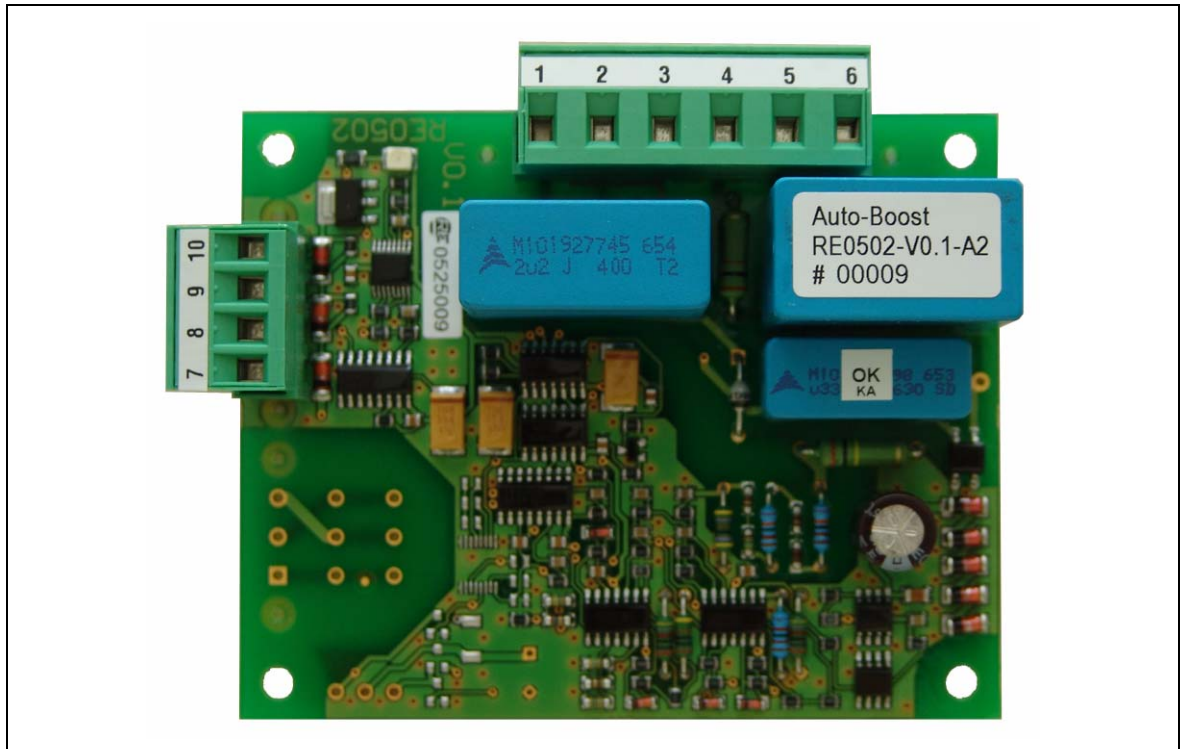

Terminal designation

Terminal	Short term	Specification
1	L1	L1 of the measuring voltage and operating voltage
2	N	N of the measuring voltage and operating voltage
3	J1.1	Port No. 1 of Jumper J1 (for 115V connect with port No. 4)
4	J1.2	Port No. 2 of Jumper J1 (for 115V connect with port No. 3)
5	J2.1	Port No. 1 of Jumper J2 (for 115V connect with port No. 6)
6	J2.2	Port No. 2 of Jumper J2 (for 115V connect with port No. 5)
7	SSR1+	Output No. 1 (positive) for Solid State Relay (SSR) No.1
8	SSR1-	Output No. 2 (negative) for Solid State Relay (SSR) No.1
9	SSR2+	Output No. 1 (positive) for Solid State Relay (SSR) No.2
10	SSR2-	Output No. 2 (negative) for Solid State Relay (SSR) No.2

D.8.5 Jump start at high starting current (Booster)

Additionally, the automatic start booster is located on the circuit control board. The starting current is increased by connecting a second group of capacitors (C2), if the voltage drops below a pre-set voltage. The starting current can be increased by 300% for a short period by combining both components voltage/speed control and ASB Start booster.

D.9 Insulation test

ATTENTION: Once the electrical system installation is complete, a ground insulation test must be performed as follows:

1. Switch off all on-board electrical devices.
2. Start the generator.
3. Measure the AC-voltage with a voltmeter (adjust to Volt/AC) between:
 - a. generator housing and AC-Control box
 - b. generator housing and ground.

The measured voltage must not exceed 50mV (millivolts).

4. Once the safety systems have been installed, they must be checked. If a leakage current relay has been installed, it also has to be tested. In order to ensure that the leakage voltage relay functions properly, the individual generated phases from the generator must be checked between each other, between phase and ground, (the single phase or 4th phase also needs to be checked in this fashion).
5. If the generator is protected by a ground connection, then **ALL** electrical devices, must also be connected to this "common" ground (usu. ground contacts are attached to the devices' metallic housings).

The electrical system installation must also comply to the hook-up requirements of the shore current grid. Generally a leakage current relay is sufficient for safe electrical operation, however, this must be confirmed by the electrical safety standard in the region where the system is attached to a main land power grid. The relay has to be meet the required safety standard regulations.



In addition to a proper circuit diagrams, terminal points, connections, electrical devices, etc. should also be labelled with stickers or signs

There is always the possibility that circuits have been rerouted/changed or individual components have not been not been correctly laid out on the circuit diagrams.

The installation electrician should therefore check and label all electrical connections to ensure that they correspond to the main circuit diagram. The inspection and correct labelling is especially critical for terminals L1/L2/L3/N & 1/2/3/4 for the 60Hz (120V) models. The electrician is **therefore obliged, before** installation to check whether the generator is earth-free. As long as this test has not been carried out all other components for electrical installation must be removed. Once the system has been installed and inspected, this test should also be performed with all electrical devices (i.e. voltage check between common and metallic housings) while the generator is running.

D.10 Voltage controller

With a engine-operated generator set count always on the fact that through disturbances at the controlling of the diesel engine the control of the number of revolutions monitoring is lost. In this case the diesel engine could wind up without limitation and produce a voltage, which becomes substantially larger than the electrical consumers can process. This can destroy very expensive items of equipment. It must be take for granted that for the protection of the electrical consumers a voltage controller with isolating relays is used for a solid installation. The appropriate accessory components are available at Icemaster.

If it is about a duo combination generator, the voltage control for both output parts (single phase AC and three-phase AC) should be planned.

At different PANDA generators a voltage control is integrated. This voltage control affects only the diesel engine. If the rated voltage exceed approx. 15%, this voltage control is activated, as the diesel engine is turned off. This is only possible with the delay of some seconds, consumers could be damaged in the meantime. The only safe method for the protection of the electrical devices is the installation of an external voltage controller with separation contactor.

We recommend this measure with all reproduction and point out also that the generator manufacturer is not responsible for damage, which are caused by overvoltage at external devices.

Protect your valuable devices by an external voltage controller!

Position of the external voltage controller

Reasonable the external voltage controller is mounted in such a way it works not only for the generator but for all AC voltage supplies in the electrical system, also for shore power and inverter. In these cases usually a selector switch is intended, which can be determined, which voltage supply is switched to the electrical system. The voltage controller must be installed at the exit of the selector switch, thus in the electrical system.

D.10.1 Adjustment of the rated voltage

The voltage controller must be ordered for the appropriate rated voltage (12, 24, 32, 48, 42 V DC). Other voltage on request.

Changing between these voltages is not possible.

D.10.2 Functional description of the voltage controller

The voltage controller has 3 different adjustment possibilities:

upper switching point, lower switching point and time lag of the generator.

In factory setting the voltage controller is in the following attitude:

- a. upper switching point (disconnection) 13.6V
- b. lower switching point (insertion) 11.52V

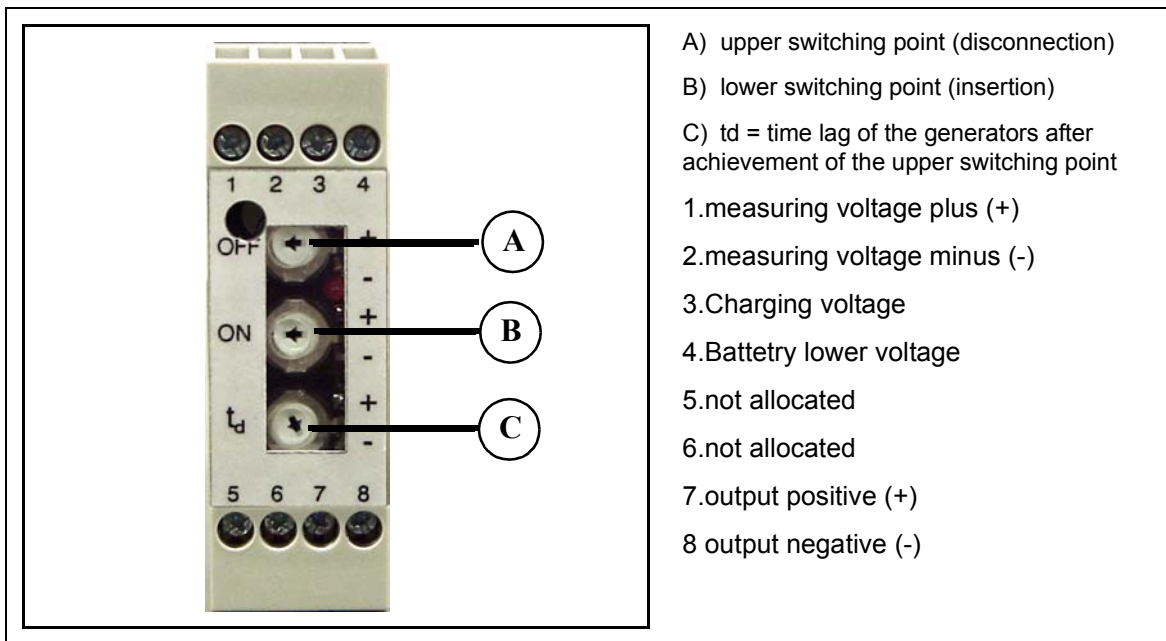

D.10.3 Time lag of the switching points

For the upper as well as for the lower switching point a time delay is adjusted. That is, the voltage must have overstep or fall short of the switching point on the time lag.

Following values are adjusted:

- a. upper switching point (13,6V), lag: min. 20 seconds
- b. lower switching point (11,52V), lag: 40 seconds

Additional notes to the recommendation "External, electrical voltage controller"

At Diesel engines count always on the fact that a diesel engine "revs up" due to special circumstances uncontrolled. This is the case if by damage to the system engine oil arrives into the sucking in way. This is possible at many engines by the crank case exhaust. A crank damage could cause for example that by overpressure too much oil is pressed into the crank case, so that this oil arrives into the sucking in way. The engine cannot switch off itself any longer. Usually then a damage to the engine is the result. It would be fatal, even if this damage to the engine were the cause of the destruction of all switched on electrical consumers, because uncontrolled revving up of the Diesel engine leads also to an extreme increase of the voltage. Only by an external voltage controller with separation contactor can be prevented such damage.

F. Tables

F.1 Troubleshooting

GENERATOR OUTPUT VOLTAGE TOO LOW

For 60Hz versions: less than 100V

Cause	Solution
Generator is overloaded.	Reduce the electrical load. (Switch off consumers)
Motor is not reaching the rated rpm.	Refer to "motor faults" section.
Defective capacitor(s).	Check capacitors and replace if necessary.

GENERATOR VOLTAGE TOO HIGH (MORE THAN 135V-60Hz)

If the generator is providing excessively high voltage, the following potential causes should be investigated:

Cause	Solution
Over-energizing due to wrong capacitors.	Check capacitors type and replace if necessary.
Measuring voltage on the VCS circuit board is missing.	Check VCS System, check cable connections.

GENERATOR VOLTAGE FLUCTUATES

Cause	Solution
1. Disturbances on the electrical system/user side. 2. Motor disturbances.	1. Check if electrical load is fluctuating. 2. Refer to section: "Motor runs irregular".

GENERATOR NOT ABLE TO START ELECTRIC MOTOR

Cause	Solution
If the generator is unable supply enough power to start an electric motor (120V-60Hz), it is usually because the motor draws too much current during starting process.	Check the motor's current draw required for starting (switch to 380V if possible). This could be remedied by providing stronger capacitors or installing an optional "Easy Start Booster Set". (See App. G) Enquire at your nearest Panda dealer or directly at the manufacturer.

DIESEL MOTOR FAILS TO START	
Cause	Solution
Starter battery switched "OFF".	Check position of battery switch and switch "ON" (if installed).
Starter battery voltage insufficient (battery too weak).	Inspect battery terminals and cables for a good electrical connection (Inspect against corrosion, tattered wires, etc.).
Starting current disrupted.	During the normal starting process, the battery voltage drops to 11V with a fully charged battery. If the voltage does not drop during starting, the electrical connection is faulty. If the battery voltage drops lower than 11V, then the battery has been discharged.

STARTER IS TURNING MOTOR, BUT FAILS TO START	
Cause	Solution
Fuel inlet solenoid valve not opening.	Check wire connections and circuitry to solenoid valve. (ref. DC wiring diagram: Relay K2, Fuse)
Fuel pump not working.	Check fuel-filter and pump: clean if necessary.
Lack of fuel.	Check fuel supply.
Glow-plugs not working correctly.	Check glow plugs and heating time.
Too much air in fuel lines.	Test fuel system for leakage. Bleed air from fuel system (refer to section "Bleeding Air from Fuel System").
Fuel-filter blocked.	Replace fuel filter.

MOTOR RUNS IRREGULARLY	
Cause	Solution
Faulty centrifugal injector governor.	Have the centrifugal governor inspected by a Farymann-Service technician.
Too much air in fuel lines.	Bleed air from fuel system.

MOTOR DOES ACHIEVE ENOUGH SPEED DURING STARTING PROCESS	
Cause	Solution
Starter battery voltage insufficient.	Check battery.
Damaged bearing(s) piston (seized).	Repairs need to be carried out by Farymann-Service. (refer to Farymann motor-manual)
Cooling water in combustion chamber.	<ol style="list-style-type: none"> 1. Turn generator "OFF" at control panel. 2. Remove the glow plug (see Farymann-manual). 3. Rotate the motor by hand carefully. 4. Check if there is water in the oil and change both oil and filter if necessary. 5. Determine cause for excess water in the combustion chamber. The excess water can be caused by a defective air vent in the cooling water system, which should be checked and cleaned, or replaced if faulty.

MOTOR SPEED DROPS	
Cause	Solution
Lack of fuel	Check fuel supply system: <ul style="list-style-type: none"> - fuel filter, renew if necessary - check fuel pump - check fuel lines (bleed if necessary)
Lack of intake air.	Check air intake paths. Check and clean air filter (and intake muffler if installed).
Generator overloaded by too many consumers.	Reduce the electrical load (switch off consumers).
Generator overloaded by over-energizing.	Check that the proper capacitor type is installed and that they are connected correctly.
Defective generator (windings, bearings, or other).	Generator must be sent to manufacturer for repair of damaged bearings or winding.
Damaged engine.	Repair of bearing damage, etc., by Farymann-Service.

MOTOR RUNS IN OFF POSITION	
Cause	Solution
Fuel inlet solenoid valve or throttle shut solenoid is not switching off.	Check wire connections to solenoid. Check valve functions as in the "Fuel Solenoid Valve" or in the throttle shut off solenoid sections. Replace if necessary.

MOTOR STOPS BY ITSELF	
Cause	Solution
Lack of fuel.	Check fuel supply system.
Excess heat in cooling system (thermo switch tripped)-lack of cooling water. Is indicated on the remote control panel.	Check cooling water system flow: water pump, inlet water filter, extra heat exchanger coolant flow.
Lack of oil (oil pressure sensor tripped). Is indicated on the remote control panel.	Check oil-level and if necessary top up. Check motor's oil-pressure and have repaired by Farymann-Service if necessary.

SOOTY, BLACK EXHAUST	
Cause	Solution
Generator is overloaded.	Check electrical load and switch off unnecessary consumers.
Insufficient intake air.	Check intake air filter; clean if necessary.
Fuel injector faulty.	Replace injector.
Valve clearance incorrect.	Readjust valve clearance to correct value (refer to Farymann-manual).
Poor fuel quality.	Use better quality diesel (recommended: 2-D Diesel).
Poor combustion.	Incorrect AFR (air/fuel ratio) due to motor timing adjustment. Have motor serviced by Farymann.

GENERATOR MUST BE SHUT OFF IMMEDIATELY IF:	
Cause	Solution
<ul style="list-style-type: none"> - motor rpm suddenly rises or drops - unusual noise comes from genset - exhaust colour suddenly becomes dark - leakage in the cooling water system. 	Refer to respective section of manual and if necessary, have repaired by Farymann-Service, or Panda representative.

F.2 Technical Data Engine

Type	Farymann 18W430
Govenor	mechanical
Cylinder	1
Bore	82 mm
Stroke	55 mm
Stroke volume	290 cm ³
max. power (DIN 6271 IFN-ISO)	5,7 kW
Nominal speed 60 Hz	3600 rpm
Idle running speed ^a	3690 rpm
Valve clearance (engine cold)	0,1 - 0,2 mm
Cylinder head nut torque	30-33 Nm
Compression ratio	20:1
Lubrication oil capacity	1,25 l
Fuel consumption ^b	approx. 0,42- 1,12 l
Oil consumption	max. 1% of the fuel consumption
Cooling water requirement for raw water circuit	10-12 l/min
Permissible max. permanent tilt of engine	a) 25° across the longitudinal axis b) 20° in the longitudinal direction

a. progressive govenor by VCS

b. 0,35l/kW electrical power, the randomized values between 30% and 80% of the rating power

F.3 Technical Data Generator

Generator	Panda 4500 FCB
Nominal power	3,8 kW , 3000mtr nn., 50°C
Nominal voltage	230V / 50 Hz single phase 230V;400V / 50 Hz 3 phase
max. current	32 A
Frequency	50 Hz
Cable cross-section	230V - 1 phase 2 x 4,0 mm ² 400V - 3 phase 4 x 2,5 mm ²
ohmic resistance coil	HP1: L / H: 0,75 Ohm, L / Z: 0,55 Ohm DVS: L1/L2/L3 - N: 1,2 Ohm, L1'-N: 0,6 Ohm
inductive resistance coil	HP1: L / H: 6,5 mH, L / Z: 3,9 mH DVS: L1/L2/L3 - N: 5,2mH; L1'-N: 3,75 mH
Voltage stator coil	1phase.: L-N: 2-4V 3phase.: L1-L2/L2-L3/L2-L3: 2-4V L1'-N: 1-2V
Coolant hoses [Ø / mm]	Fresh water / raw water: 12
Exhaust hose [Ø / mm]	30
Fuel hoseh [Ø / mm]	Supply / return: 8



F.4 Types of coil

HP1 - 230V / 50 Hz

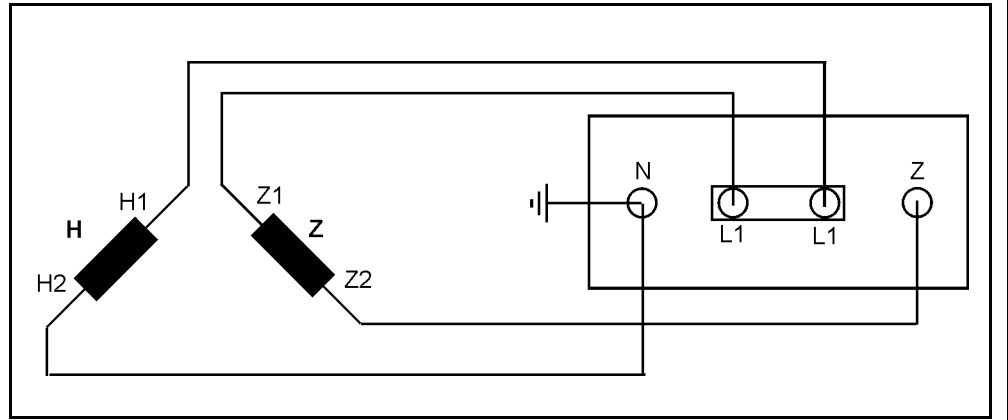

HP3 - 400V / 50 Hz

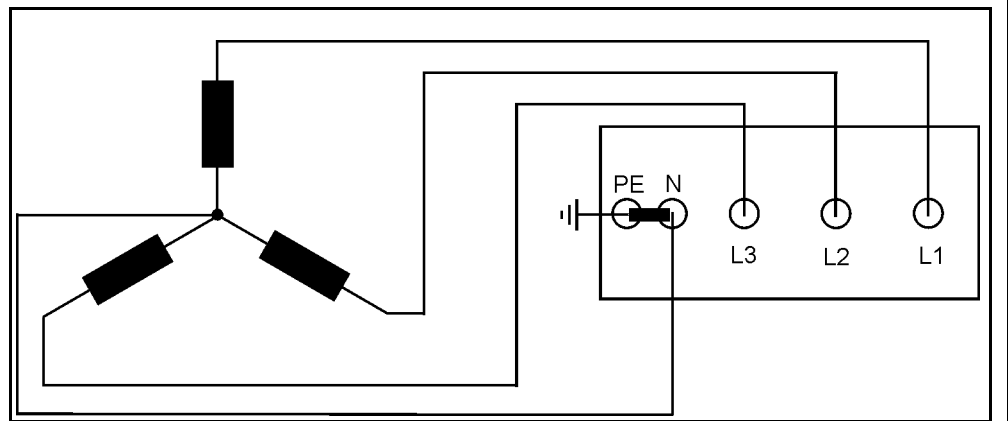

DVS - 400V / 50 Hz

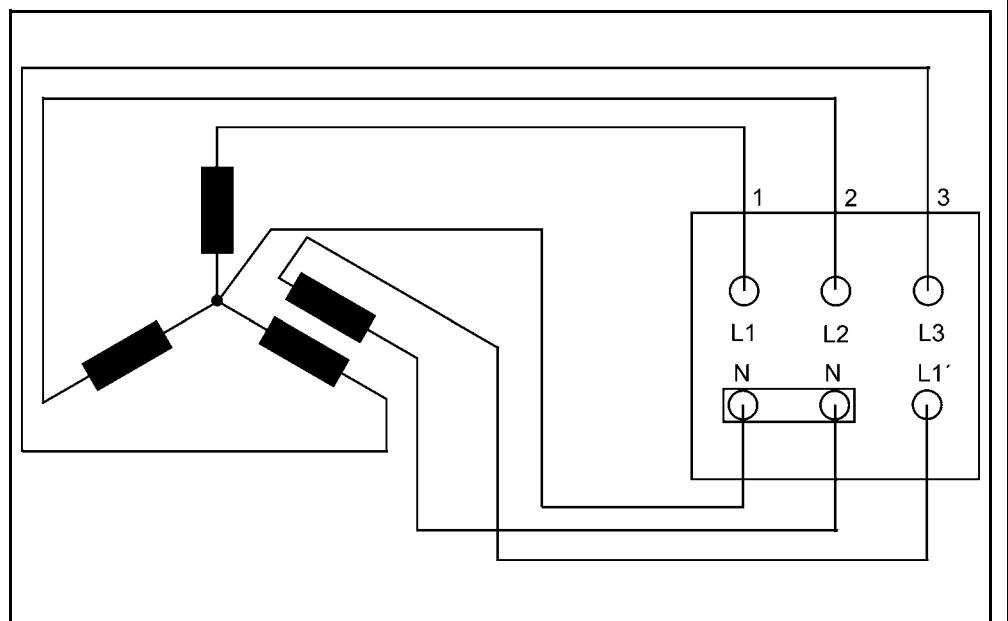

F.5 Inspection checklist for services

Inspection-Category			
A	Installation check /	D	100 h
		E	500 h
B	daily	F	1000 h
C	35 - 50 h	G	5000 h

Inspection work			
1)	check r	4)	changer
2)	measure	5)	sealing
3)	clean	6)	check isolation

	Inspection-Category							Inspection work
	A	B	C	D	E	F	G	
01.	5)	5)	5)	5)	5)	5)	4)	coolant water hoses
02.	1)	1)	1)	1)	1)	4)	4)	raw water pump (impeller)
03.	1)	1)	3)	3)	3)	3)	3)	water separator / fuel pre-filter
04.	1)	1)	4)	4)	4)	4)	4)	engine oil
05.				3)	3)	3)	3)	oil strainer
06.	1)	1)	1)	4)	4)	4)	4)	air filter
07.	1)	1)	1)	1)	1)	1)	1)	fuel lines (leaks)
08.	1)	1)	1)	4)	4)	4)	4)	fine particle fuel filter
09.	1)		1)		1)	1)	1)	valve clearance
10.	1)	1)	4)	5)	4)	4)	4)	valve cover gasket
11.			1)		1)	1)	1)	coolant therm (sensor)
12.			1)		1)	1)	1)	exhaust temp sensor
13.			1)		1)	1)	1)	oil pressure sensor
14.		1)	1)	1)	1)	1)	1)	belt tension
15.	1)	1)	1)	1)	4)	4)	4)	toothed-belt
16.						1)	1)	thermostat
17.	1)	1)	1)	1)	1)	1)	1)	generator & engine screws
18.	1)	1)	1)	1)	1)	1)	1)	unit's base mount screws
19.	6)	6)	6)	6)	6)	6)	6)	check electrical cables
20.	1)	1)	1)	1)	1)	1)	1)	motor reinforced mountings
21.	1)	1)	1)	1)	1)	1)	1)	starter motor mounting screws
22.	1)	1)	1)	1)	1)	1)	1)	screws generator-engine
23.	2)		2)	2)	2)	2)	2)	input temp of coolant under load
24.	2)		2)	2)	2)	2)	2)	outlet temp of coolant under load
25.						4)	4)	generator rotor bearing
26.			1)	1)	1)	1)	1)	signs of corrosion to generator
27.			1)	1)	1)	1)	1)	check generator coolant block
28.			1)	1)	1)	1)	1)	capacitors in AC-Control box
29.	1)		1)	1)	1)	1)	1)	ASB function test
30.	1)		1)	1)	1)	1)	1)	VCS function test
31.	2)		2)	2)	2)	2)	2)	voltage without load
32.	2)		2)	2)	2)	2)	2)	voltage under load
33.	2)		2)	2)	2)	2)	2)	generator output under load
34.	2)		2)	2)	2)	2)	2)	engine speed (rpm)
35.						1)	4)	injector test
36.						1)	1)	compression
37.	1)	1)	1)	1)	1)	1)	1)	hose clips

F.6 Engine oil

Engine oil classification

Operating range:

The operating range of an engine oil is determined by SAE class. "SAE" is for the union of American engineers (Society of Automotives Engineers). The SAE class of an engine oil only informs over the viscosity of the oil (larger number = more viscous, lower number = more highly liquidly) e.g. to 0W, 10W, 15W, 20, 30, 40. The first number shows the liquid of cold weather, the second number refers to the fluidity with heat. Complete yearly oils have usually SAE 10W-40, SAE 15W-40 etc.

Quality of oil:

The quality of an engine oil is specified by the API standard ("American Petroleum Institutes"). The API designation is to be found on each engine oil bundle. The first letter is always a C.

API C for diesel engines

The second letter is for the quality of the oil. The more highly the letter in the alphabet, the better the quality.

Examples for diesel engine oil:

API CG Engine oil for highest demands, turbo-tested

Engine oil types	
above 25°C	SAE30 or SAE10W-30 SAE10W-40
0°C to 25°C	SAE20 or SAE10W-30 SAE10W-40
below 0°C	SAE10W or SAE10W-30 SAE10W-40

F.7 Coolant

Use a mixture of water and antifreeze. The antifreeze needs to be suitable for aluminium. The antifreeze concentration must be regularly checked in the interests of safety.

ICEMASTER recommend to use the product: GLYSANTIN PROTECT PLUS/G 48.

Engine coolant automotive industry Product description		
Product name	GLYSANTIN ® PROTECT PLUS / G48	
Chemical nature	Monoethylenglycol with inhibitors	
Physical form	Liquid	
Chemical and physical properties		
Reserve alkalinity of 10ml	ASTM D 1121	13 – 15 ml HCl 01 mol/l
Density, 20°C	DIN 51 757 procedure 4	1,121 – 1,123 g/cm ³
Water content	DIN 51 777 part 1	max. 3,5 %
pH-value undiluted		7,1 – 7,3

Coolant mixture ratio	
Water/antifreeze	Temperature
70:30	-20°C
65:35	-25°C
60:40	-30°C
55:45	-35°C
50:50	-40°C

F.8 Capsule Measurements

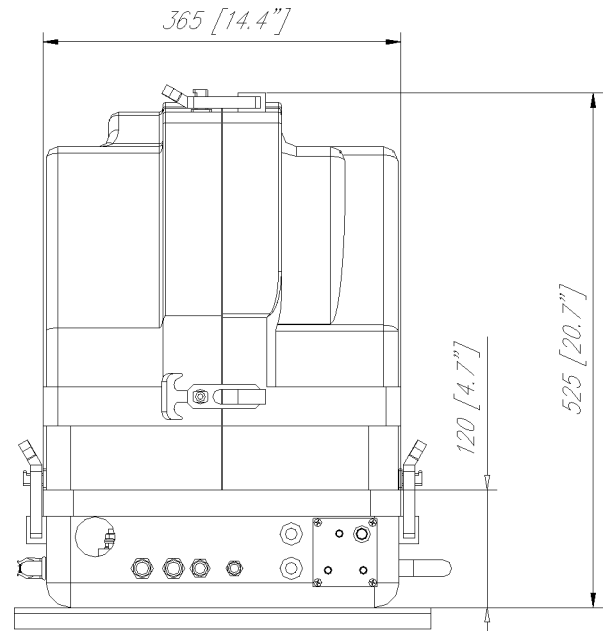
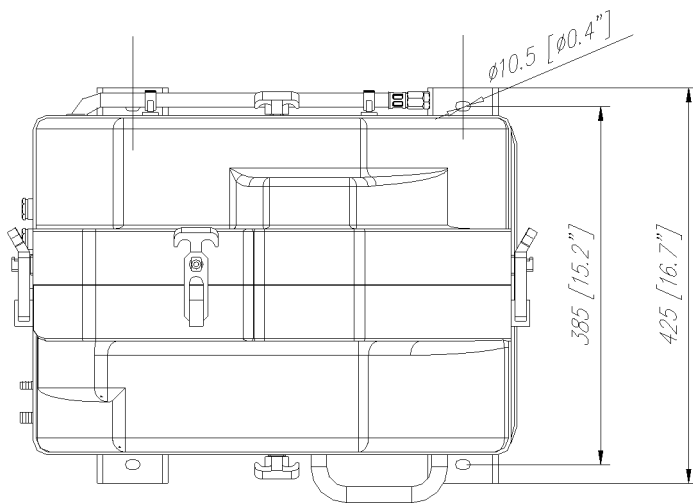
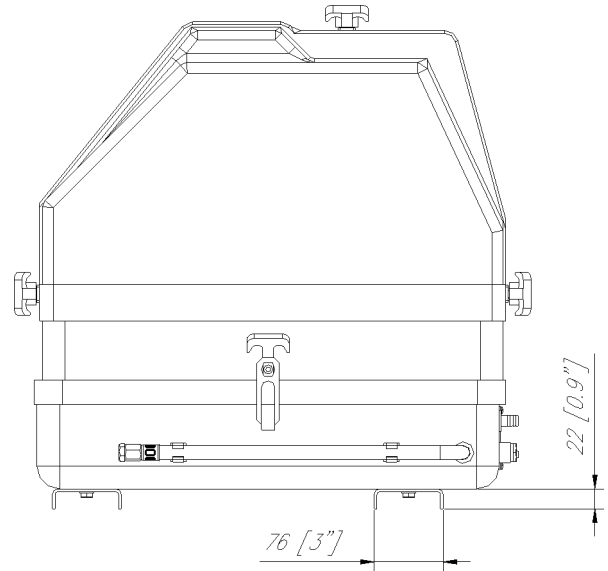
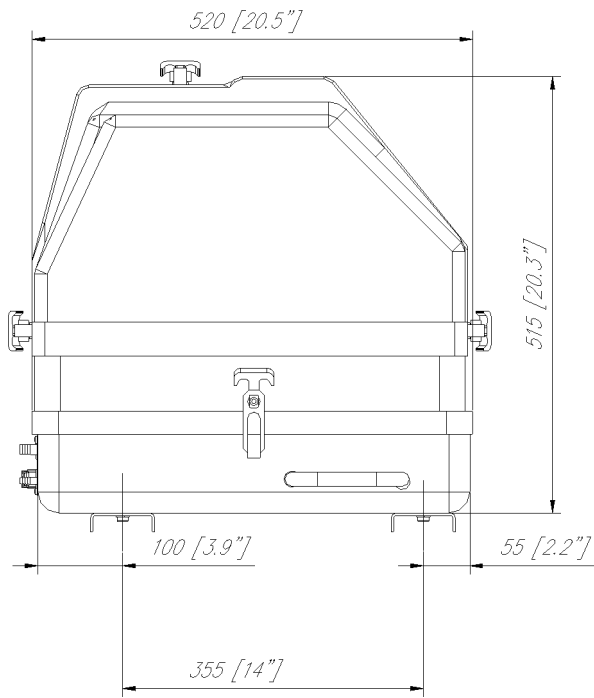

F.9 Cooling water flow Panda 4500 FCB

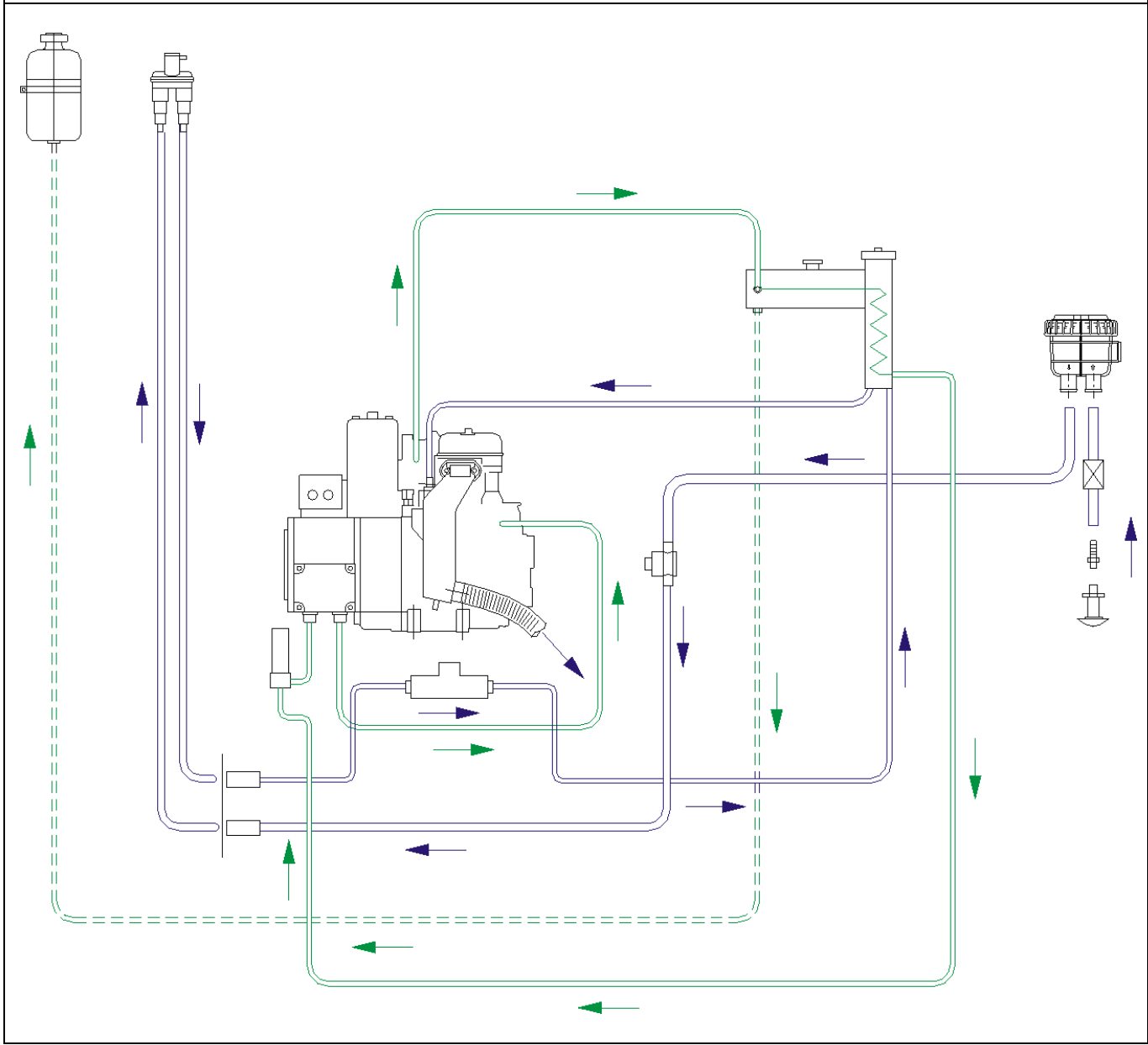

	Freshwater flow
	Raw water flow



5 Safety steps to follow if someone is the victim of electrical shock

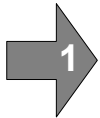

Do not try to pull or grab the individual.

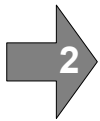

Send for help as soon as possible.

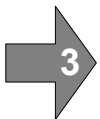

If possible, turn off the electrical power.

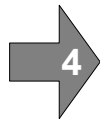

If you cannot turn off the electrical power, pull, push, or lift the person to safety using a wooden pole, rope, or some nonconductive material.

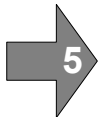

After the injured person is free of contact with the source of electrical shock, move them a short distance away and immediately start necessary first aid procedures.

WHEN AN ADULT STOPS BREATHING

WARNING

DO NOT attempt to perform the rescue breathing techniques provided on this page, unless certified. Performance of these techniques by uncertified personnel could result in further injury or death to the victim.

1 Does the Person Respond?

- Tap or gently shake victim.
- Shout, "Are you OK?"

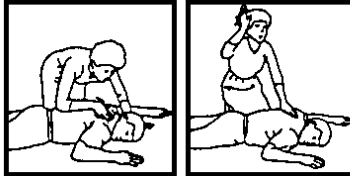

3 Roll Person onto Back.

- Roll victim toward you by pulling slowly.

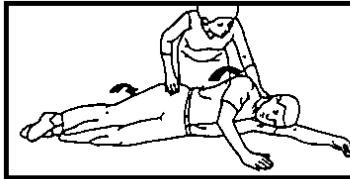

4 Open Airway.

- Tilt head back, and lift chin.
- Shout, "Are you OK?"

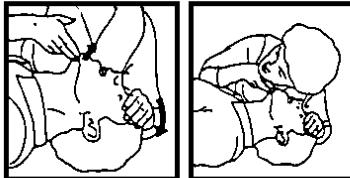

6 Give 2 Full Breaths.

- Keep head tilted back.
- Pinch nose shut.
- Seal your lips tight around victim's mouth.
- Give 2 full breaths for 1 to 1½ seconds each.



7 Check for Pulse at side of Neck.

- Feel for pulse for 5 to 10 seconds.



9 Begin Rescue Breathing.

- Keep head tilted back.
- Lift chin.
- Pinch nose shut.
- Give 1 full breath every 5 seconds.
- Look, listen, and feel for breathing between breaths.



2 Shout, "Help!"

- Call people who can phone for help.

5 Check for Breathing.

- Look, listen, and feel for breathing for 3 to 5 seconds.

8 Phone EMS for Help.

- Send someone to call an ambulance.

10 Recheck Pulse Every Minute.

- Keep head tilted back.
- Feel for pulse for 5 to 10 seconds.
- If victim has pulse, not breathing, continue rescue breathing. If no pulse, begin CPR.