

ifm electronic



Operating instructions
Flow rate meter for gases

efector300[®]

SD5100

UK

704137 / 01 07 / 2010

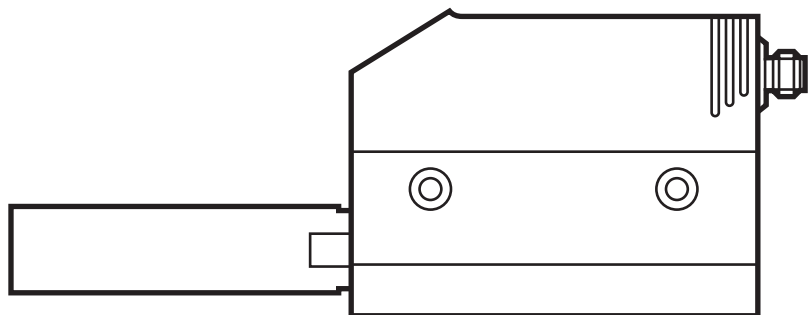

Contents

1	Preliminary note.....	4
1.1	Symbols used	4
2	Safety instructions	4
3	Functions and features	5
4	Function	5
4.1	Processing of the measured signals.....	5
4.2	Volumetric flow monitoring.....	5
4.3	Consumed quantity monitoring (totalizer function)	5
4.3.1	Consumed quantity monitoring with pulse output.....	6
4.3.2	Consumed quantity monitoring with preset meter	6
4.4	Monitoring of temperatures.....	6
4.5	Volumetric flow monitoring / switching function	6
4.6	Volumetric flow monitoring / analogue function	7
5	Installation.....	8
5.1	Installation location	8
5.2	Installation conditions	8
5.3	Mounting position	9
5.4	Installation in pipes	10
6	Electrical connection.....	10
7	Operating and display elements	11
8	Menu.....	12
8.1	Menu structure.....	12
8.2	Explanation of the menu.....	13
9	Parameter setting	14
9.1	General parameter setting.....	14
9.2	Settings for volumetric flow monitoring	15
9.2.1	Settings for limit value monitoring with OUT1.....	15
9.2.2	Settings for limit value monitoring with OUT2.....	16
9.2.3	Scaling of the analogue value for volumetric flow	16
9.3	Settings for monitoring of consumed quantities.....	16
9.3.1	Settings for quantity monitoring by pulse output.....	16
9.3.2	Settings for quantity monitoring using the preset meter	16

9.3.3	Settings for meter reset controlled by the program	16
9.3.4	Switch off the meter reset.....	17
9.4	User settings (optional).....	17
9.4.1	Determine the standard unit of measurement for volumetric flow	17
9.4.2	Configuration of the standard display	17
9.4.3	Setting the damping of the measured values	17
9.4.4	Setting the error behaviour of OUT1 / OUT2.....	17
9.4.5	Selection of the medium to be monitored	18
9.5	Service-Funktionen.....	18
9.5.1	Reading the min./max. values for volumetric flow	18
9.5.2	Reset all parameters to the factory setting.....	18
9.6	Setting of the preset meter / pulse value (ImPS).....	19
10	Operation.....	21
10.1	Read the set parameters	21
10.2	Changing the display unit in the Run mode.....	21
10.3	Error indication	21
10.4	General operating conditions.....	22
11	Scale drawing	22
12	Technical data.....	23
12.1	Setting ranges	24
13	Factory setting	25

1 Preliminary note

1.1 Symbols used

► Instruction

> Reaction, result

[...] Designation of buttons, switches or indications

→ Cross-reference



Important note

Non-compliance can result in malfunctions or interference.

2 Safety instructions

- Please read this document prior to installing the unit. Ensure that the product is suitable for your application without any restrictions.
- Work on compressed air equipment as well as mounting, setting for operation and set-up of the unit must be carried out by suitably qualified personnel. When doing so, state of the art, safety and accident prevention regulations must be adhered to.
- Ensure that the installation is at a standstill and no pressure is applied before mounting components into or removing them from compressed air equipment.
- Improper or non-intended use may lead to malfunctions of the unit or to unwanted effects in your application. That is why installation, electrical connection, set-up, operation and maintenance of the unit must be carried out by qualified personnel authorised by the plant operator.
- In all applications test the compatibility of the product materials (→ 12 Technical data) with the media to be measured.

For the scope of validity cULus: The device shall be supplied from an isolating transformer having a secondary Listed fuse rated as noted in the following table.

Overcurrent protection		
Control-circuit wire size		Maximum protective device rating Ampere
AWG	(mm ²)	
26	(0.13)	1
24	(0.20)	2
22	(0.32)	3
20	(0.52)	5
18	(0.82)	7
16	(1.3)	10

3 Functions and features

The unit monitors the standard volume flow of gases.

It detects the 3 process categories volumetric flow, consumed quantity, medium temperature.

Applications:

- argon (Ar)
- carbon dioxide (CO2)
- nitrogen (N2)

Selection of the medium to be monitored → 9.4.5.

All data refer to standard volume flow according to DIN ISO 2533, i.e. volume flow at 1013 hPa, 15°C and 0% relative air humidity.

The general operating conditions of gas filled equipment apply.

UK

4 Function

4.1 Processing of the measured signals

- The unit displays the current process values.
- It generates 2 output signals according to the parameter setting.

OUT1: 3 selection options	parameter setting
switching signal for volumetric flow limit values	(→ 9.2.1)
or pulse sequence for totalising meter	(→ 9.3.1)
or switching signal for preset counter	(→ 9.3.2)
OUT2: 2 selection options	
switching signal for volumetric flow limit value	(→ 9.2.2)
or analogue signal for volumetric flow	(→ 9.2.3)

4.2 Volumetric flow monitoring

The flow rate is monitored by a calorimetric measuring system, the measured signals by the electronics.

- 2 switching signals for volumetric flow limit values can be provided (output 1 and output 2). For the switching functions → 4.5.
- An analogue signal proportional to the volumetric flow (4...20 mA) can be provided on output 2. For the analogue functions → 4.6.

4.3 Consumed quantity monitoring (totalizer function)

The unit has an internal quantity meter which continuously totals the volumetric flow. The sum corresponds to the current consumed quantity since the last reset.

- The current meter count can be indicated.
- In addition the value before the last reset is stored. This value can also be indicated.

The meter saves the totalled consumed quantity every 10 minutes. After a power failure this value is available as the current meter count. If a time-controlled reset is set, the elapsed time of the set reset interval is also stored. So the possible data loss can be maximum 10 minutes.

The meter can be reset as follows:

- Manual reset (→ 9.3.3).
- Time-controlled automatic reset (→ 9.3.3).

4.3.1 Consumed quantity monitoring with pulse output

Output 1 provides a counting pulse if the value set in [ImPS] is reached (→ 9.3.1).

4.3.2 Consumed quantity monitoring with preset meter

2 types of monitoring are possible:

- Time-dependent quantity monitoring
 - Settings: [ImPS] = quantity x, [ImPR] = [no], [rTo] = time t.
 - If the quantity x is reached during the time t, output 1 switches and remains switched until the meter is reset.
 - If the quantity x has not been reached after the time t, the meter is automatically reset and counting starts again; output 1 does not switch.
- Quantity monitoring not time-dependent
 - Settings: [ImPS] = quantity x, [ImPR] = [no], [rTo] = [OFF].
 - If the quantity x is reached, output 1 switches and remains switched until the meter is reset.

4.4 Monitoring of temperatures

- The unit detects the current system temperature and shows it on the display (→ chapter 10.2 Changing the display unit in the Run mode).

4.5 Volumetric flow monitoring / switching function

OUTx changes its switching state if it is above or below the set switching limits (SPx, rPx). The following switching functions can be selected:

- Hysteresis function / normally open (fig. 1): [OUx] = [Hno].
- Hysteresis function / normally closed (fig. 1): [OUx] = [Hnc].

First the set point (SPx) is set, then the reset point (rPx) at the requested distance.

- Window function / normally open (fig. 2): $[OUx] = [Fno]$.
 - Window function / normally closed (fig. 2): $[OUx] = [Fnc]$.
- The width of the window can be set by means of the distance between SPx and rPx . SPx = maximum value, rPx = minimum value.

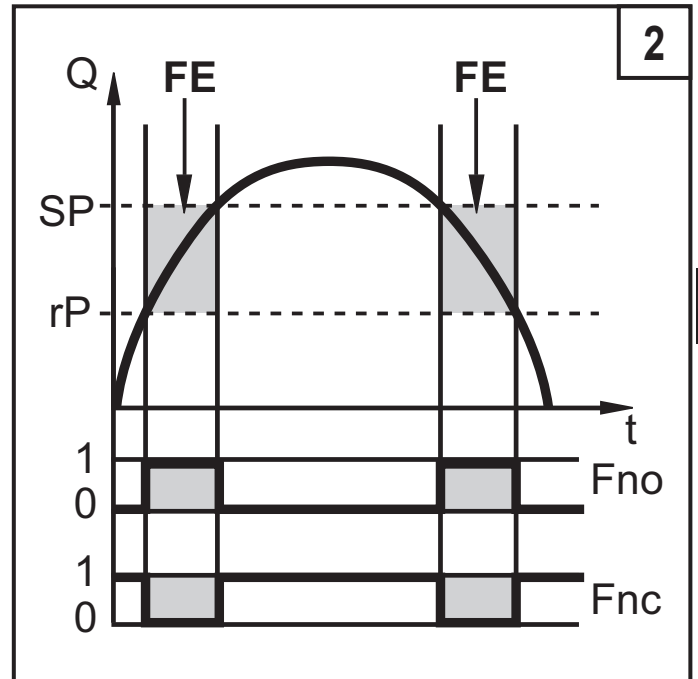
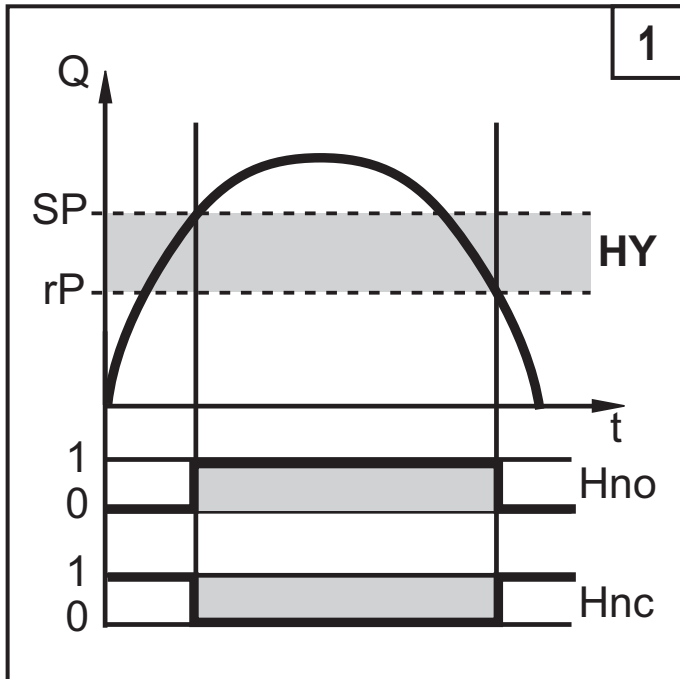

HY = hysteresis; FE = window

When set to the window function the set and reset points have a fixed hysteresis of 0.25 % of the final value of the measuring range. This keeps the switching state of the output stable if the volumetric flow varies slightly.

4.6 Volumetric flow monitoring / analogue function

- The analogue start point [ASP] determines at which measured value the output signal is 4 mA.
- The analogue end point [AEP] determines at which measured value the output signal is 20 mA.

Minimum distance between [ASP] and [AEP] = 25 % of the final value of the measuring range.

UK

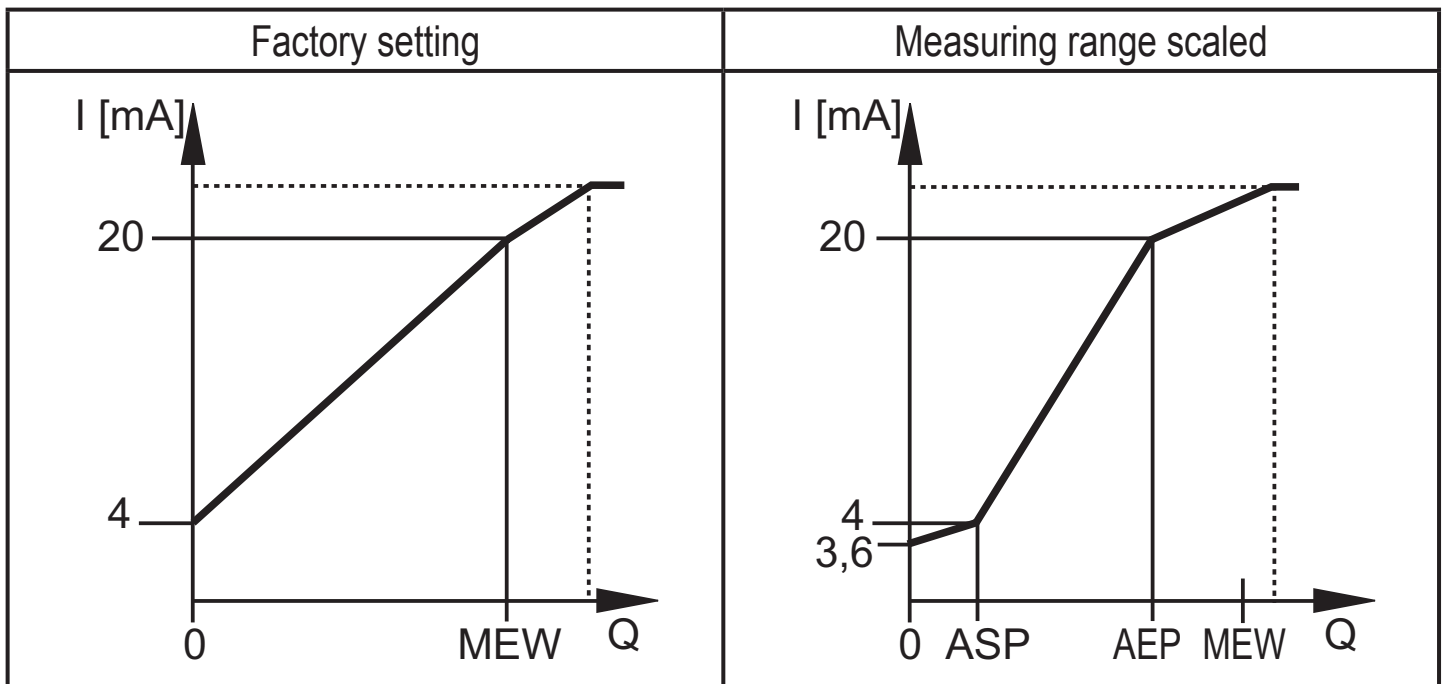

MEW = final value of the measuring range

In the set measuring range the output signal is between 4 and 20 mA.

It is also indicated:

- Volumetric flow above the measuring range: output signal > 20 mA.
- Flow rate below the measuring range: output signal between 3.6 and 4 mA.

5 Installation



The rules and regulations for the installation and operation of compressed air equipment must be observed.

5.1 Installation location





- Behind the cold dryer / near the load.
- If compressed air is fed into the main pipe through parallel pipes, the unit should be mounted in the main pipe.
- Installation after the maintenance unit is also possible. If oil is used for the loads, the unit must be mounted before the oiler.

5.2 Installation conditions

To achieve the specified measurement accuracy, the following mounting conditions must be adhered to: defined inflow / outflow pipe lengths, defined flow cross-sectional area, fixed installation depth and correct positioning of the measuring elements.

The unit is delivered mounted on a pipe section meeting these conditions.

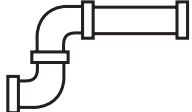
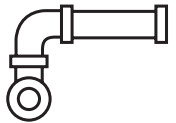
In case of turbulences at the inflow side additional baffled pipes (B) are recommended:

	changes to the pipe diameter	$B = 5 \times \text{pipe diameter}$
	90° elbow	$B = 5 \times \text{pipe diameter}$
	two 90° elbows, one plane	$B = 10 \times \text{pipe diameter}$
	two 90° elbows, two planes	$B = 15 \times \text{pipe diameter}$
	valve, slide	$B = 35 \times \text{pipe diameter}$

UK

5.3 Mounting position

- Permitted mounting positions: pipe length vertical, any position (fig. 1, 2), pipe length horizontal, unit vertical (fig. 3, 4), unit on side, pipe length left (fig. 5).
- Avoid the mounting position shown in fig. 6 (unit on side, pipe length right). If the flow rate is low, the specified measurement accuracy cannot be adhered to.

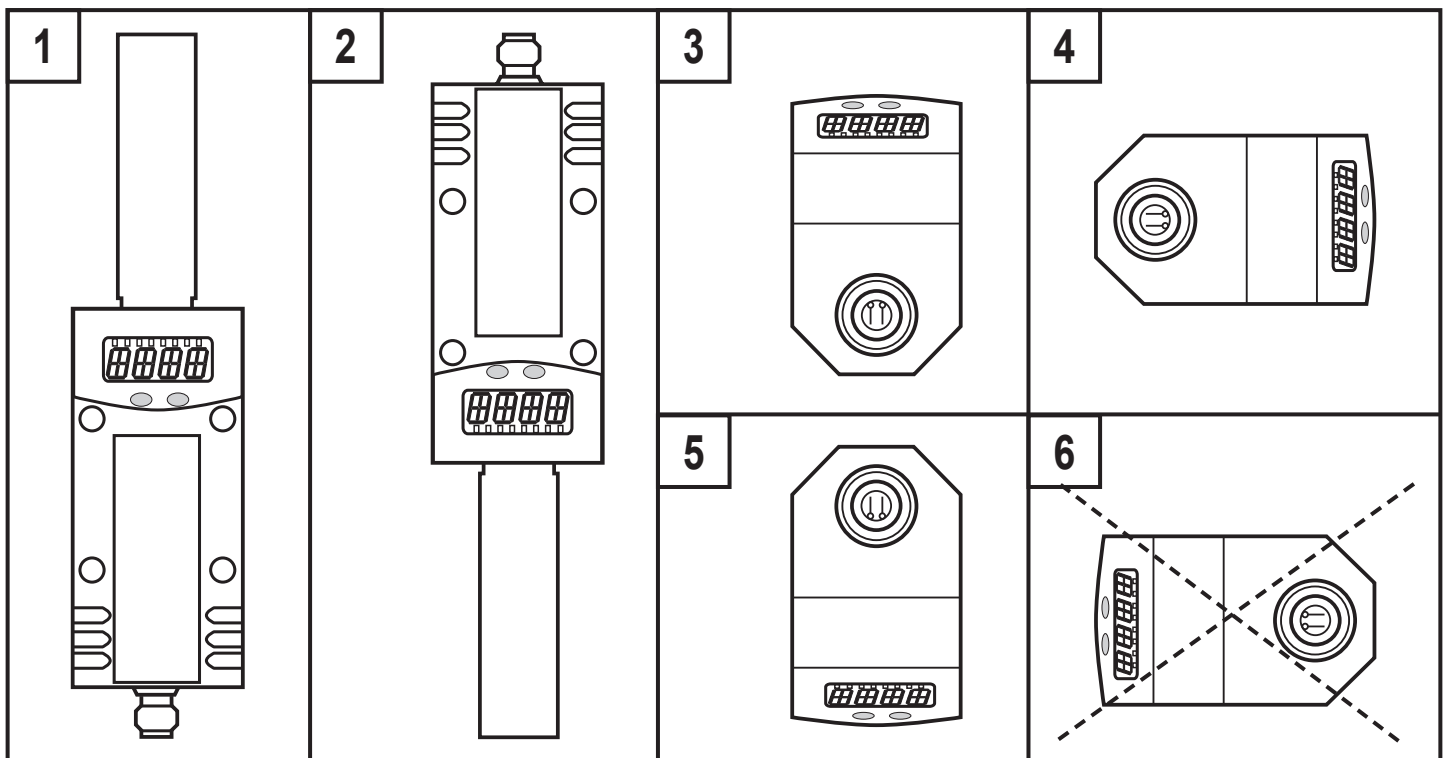

5.4 Installation in pipes

Integrate the pipe length so that the direction of flow (1) and the marking arrow (2) show in the same direction.

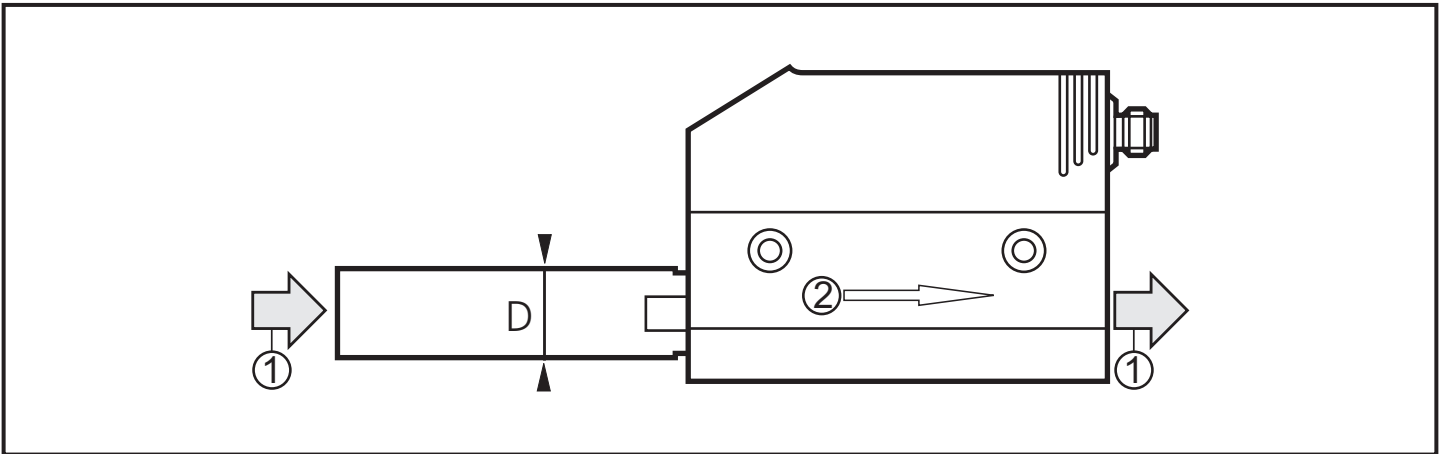

6 Electrical connection



The unit must be connected by a qualified electrician.

The national and international regulations for the installation of electrical equipment must be adhered to.

Voltage supply to EN50178, SELV, PELV.

- ▶ Disconnect power.
- ▶ Connect the unit as follows:

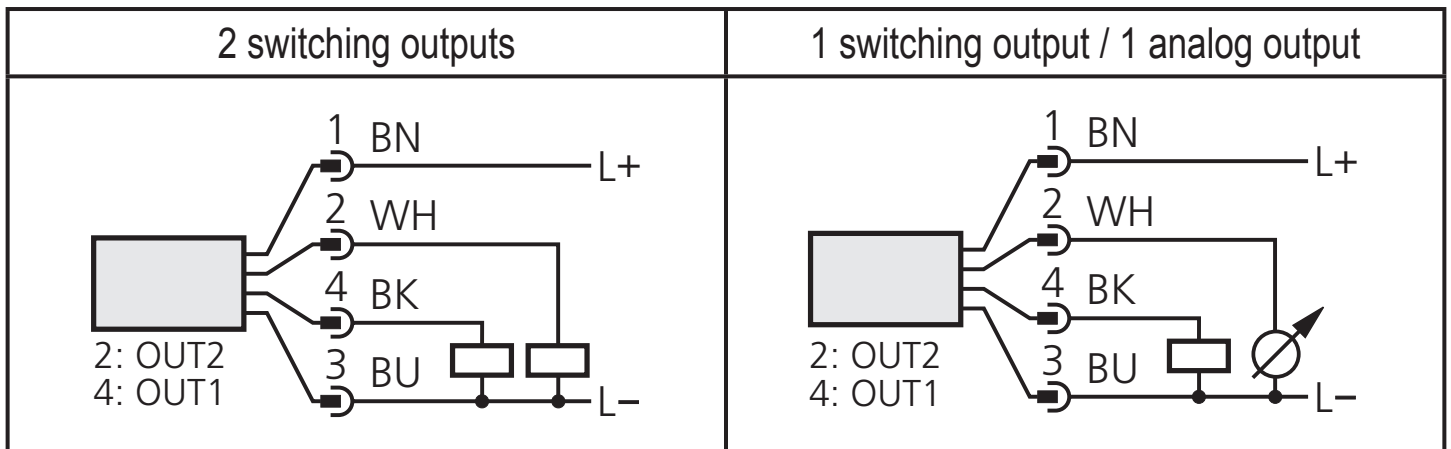

OUT1: switching signal or pulse sequence pnp

OUT2: switching signal pnp or analogue signal (I)

Core colours of ifm sockets:

1 = BN (brown), 2 = WH (white), 3 = BU (blue), 4 = BK (black).

7 Operating and display elements

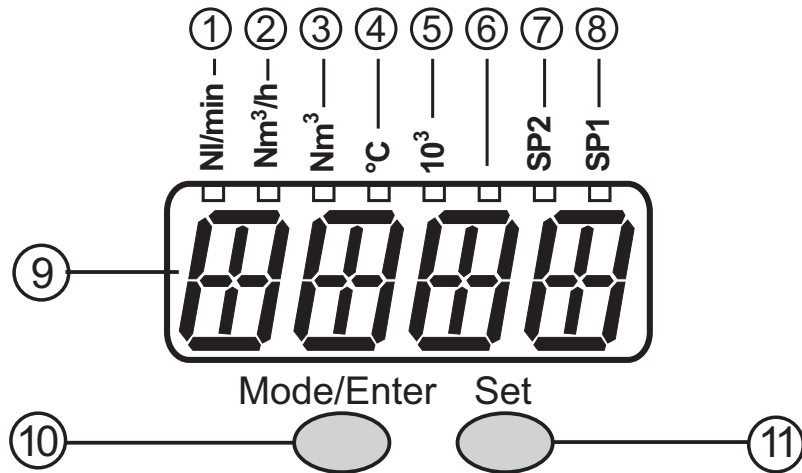

1 to 8: Indicator LEDs

- LED 1 = current volumetric flow in standard litres/minute (l/min).
- LED 2 = current volumetric flow in standard cubic metres/hour (Nm³/h).
- LED 3 = current consumed quantity since the last reset in standard cubic metres (Nm³).
- LED 3 flashing = consumed quantity before the last reset in standard cubic metres.
- LEDs 3 and 5 = current consumed quantity since the last reset in 10³ standard cubic metres.
- LEDs 3 and 5 flashing = consumed quantity before the last reset in 10³ standard cubic metres.
- LED 4 = current medium temperature in °C.
- LED 6 = not used.
- LED 7, LED 8 = switching state of the corresponding output.

9: Alphanumeric display, 4 digits

- Indication of the current volumetric flow (if [SELD] = [FLOW] is set).
- indication of the meter count (if [SELD] = [TOTL] is set).
- indication of the current medium temperature (→ 10.2).
- indication of the parameters and parameter values.

10: Mode/Enter pushbutton

- Selection of the parameters and acknowledgement of the parameter values.

11: Set pushbutton

- Setting of the parameter values (scrolling by holding pressed, incremental by pressing briefly).
- Change of the display unit in the normal operating mode (Run mode).

8 Menu

8.1 Menu structure

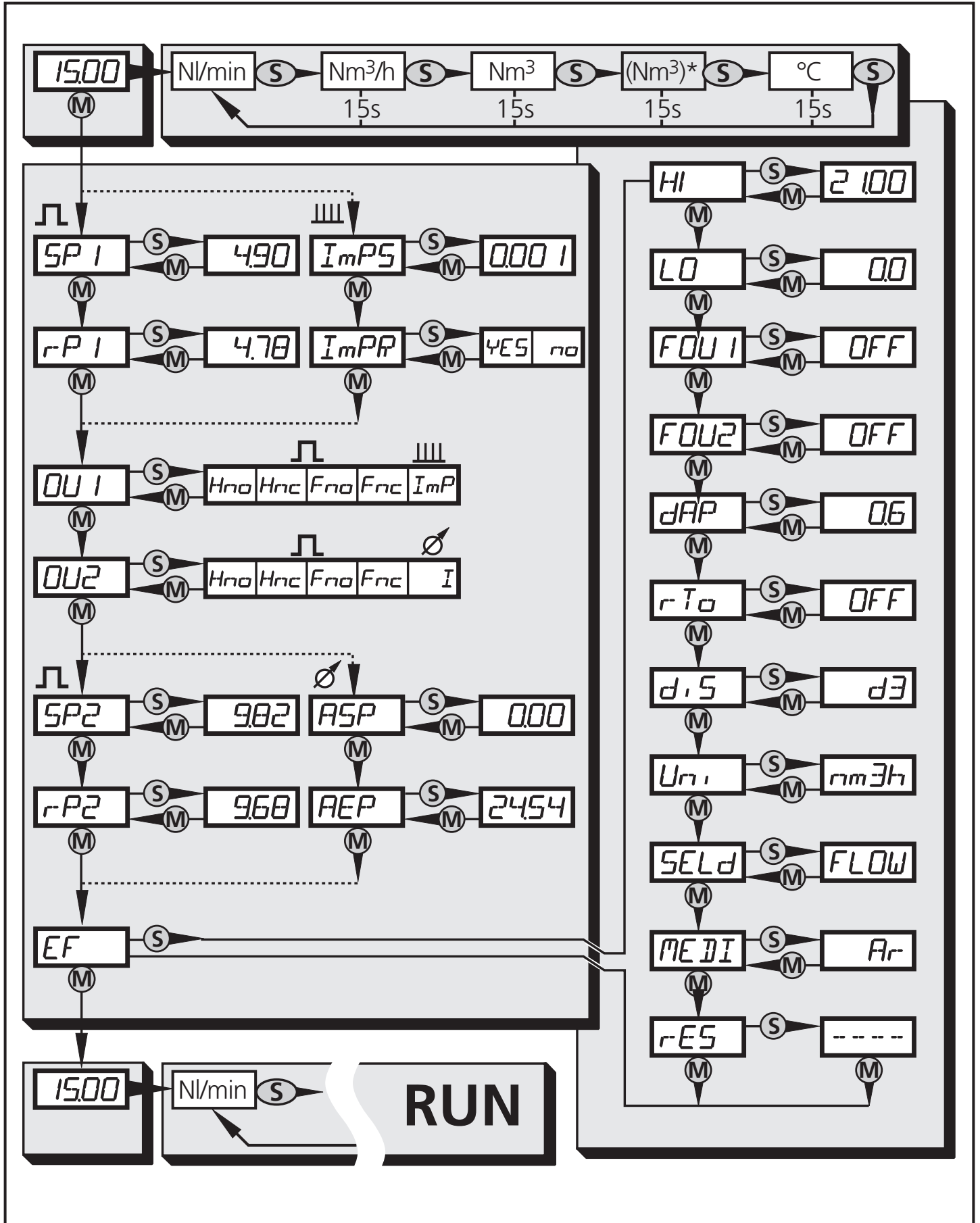

(M) = [Mode/Enter] / (S) = [Set]

Nm³ = current meter count in standard m³

(Nm³)* = stored meter count in standard m³

8.2 Explanation of the menu

SP1/rP1	Maximum / minimum value for volumetric flow, at which OUT1 changes its switching status.
ImPS	Pulse value.
ImPR	Pulse repetition active (= pulse output) or not active (= function preset meter).
OU1	Output function for OUT1 (volumetric flow or consumed quantity): - Switching signal for limit values: hysteresis function or window function, normally open or normally closed. - Pulse or switching signal for quantity meter.
OU2	Output function for OUT2 (volumetric flow): - Switching signal for limit values: hysteresis function or window function, normally open or normally closed. - Analogue signal: 4-20 mA.
SP2/rP2	Maximum / minimum value for volumetric flow, at which OUT2 changes its switching status.
ASP	Analogue start value for volumetric flow.
AEP	Analogue end value for volumetric flow.
EF	Extended functions / opening of menu level 2.
HI / LO	Maximum / minimum value memory for volumetric flow.
FOU1	Behaviour of output 1 in case of an internal fault.
FOU2	Behaviour of output 2 in case of an internal fault.
dAP	Measured value damping / damping constant in seconds.
rTo	Meter reset: manual reset / time-controlled reset.
diS	Update rate and orientation of the display.
Uni	Standard unit of measurement for volumetric flow: standard litres/minute or standard cubic metres/hour.
SELd	Standard process category of the display: volumetric flow value / meter count.
MEDI	Selection of the medium to be monitored.
rES	Restore factory setting.

UK

9 Parameter setting

During parameter setting the unit remains in the operating mode. It continues its monitoring function with the existing parameters until the parameter setting has been completed.

9.1 General parameter setting

3 steps must be taken for each parameter set:

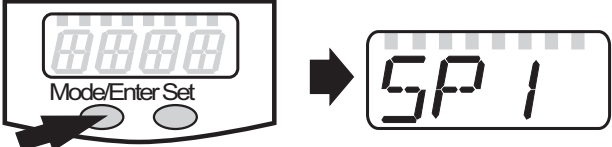
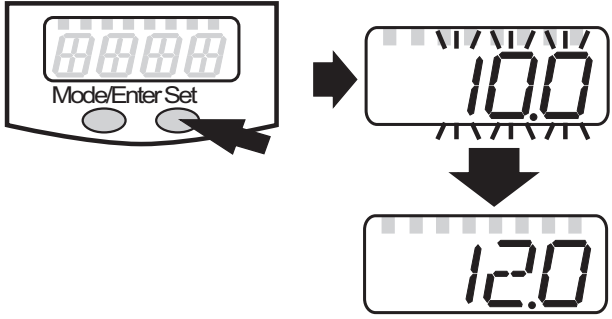
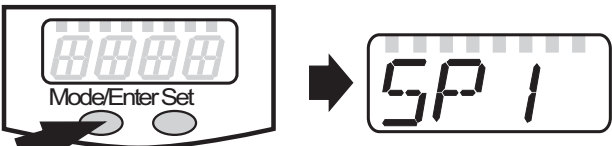
<p>1</p>	<p>Parameter selection</p> <ul style="list-style-type: none"> ▶ Press [Mode/Enter] until the requested parameter is displayed. 	
<p>2</p>	<p>Setting of the parameter value</p> <ul style="list-style-type: none"> ▶ Press [Set] and keep it pressed. > Current setting value of the parameter flashes for 5 s. > After 5 s: The setting value is changed: incremental by pressing briefly or scrolling by holding pressed. 	
<p>Numerical values are incremented continuously. If the value is to be reduced: let the display move to the maximum setting value. Then the cycle starts again at the minimum setting value.</p>		
<p>3</p>	<p>Acknowledgement of the parameter value</p> <ul style="list-style-type: none"> ▶ Press [Mode/Enter] briefly. > The parameter is displayed again. The new setting value is stored. 	
<p>Setting of other parameters</p> <ul style="list-style-type: none"> ▶ Start again with step 1. 		
<p>Finishing the parameter setting</p> <ul style="list-style-type: none"> ▶ Press [Mode/Enter] several times until the current measured value is displayed or wait for 15 s. > The unit returns to the operating mode. 		

- Change from menu level 1 to menu level 2

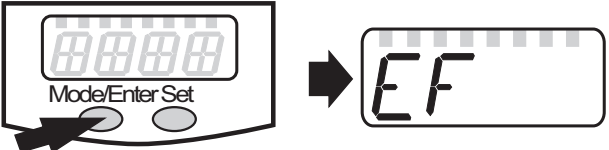
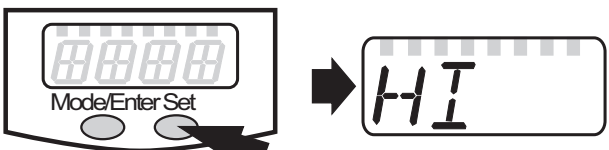
<ul style="list-style-type: none"> ▶ Press [Mode/Enter] until [EF] is displayed. 	
<ul style="list-style-type: none"> ▶ Press [Set] briefly. > The first parameter of the sub-menu is displayed (here: [HI]). 	

- Locking / unlocking

The unit can be locked electronically to prevent unintentional wrong settings. UK

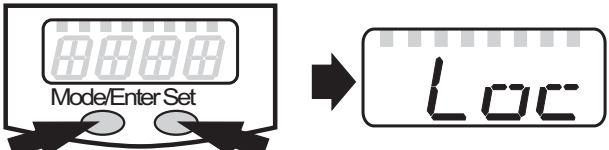
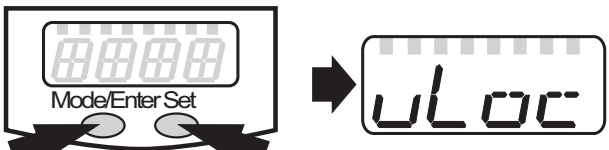
<ul style="list-style-type: none"> ▶ Make sure that the unit is in the normal operating mode. ▶ Press [Mode/Enter] + [Set] for 10 s. > [Loc] is displayed. 	
<p>During operation: [Loc] is briefly displayed if you try to change parameter values.</p>	
<ul style="list-style-type: none"> ▶ Press [Mode/Enter] + [Set] for 10 s. > [uLoc] is displayed. 	

When delivered: unlocked.

- Time out:

If during parameter setting no pushbutton is pressed for 15 s, the unit exits the parameter setting mode. The parameter value is not changed.

9.2 Settings for volumetric flow monitoring

9.2.1 Settings for limit value monitoring with OUT1

<ul style="list-style-type: none"> ▶ Select [OU1] and set the switching function: [Hno] = hysteresis function/normally open, [Hnc] = hysteresis function/normally closed, [Fno] = window function/normally open, [Fnc] = window function/normally closed. ▶ Select [SP1] and set the value at which the output switches. ▶ Select [rP1] and set the value at which the output switches back. 	
---	---

9.2.2 Settings for limit value monitoring with OUT2

<ul style="list-style-type: none"> ▶ Select [OU2] and set the switching function: [Hno] = hysteresis function/normally open, [Hnc] = hysteresis function/normally closed, [Fno] = window function/normally open, [Fnc] = window function/normally closed. ▶ Select [SP2] and set the value at which the output switches. ▶ Select [rP2] and set the value at which the output switches back. 	
---	---

9.2.3 Scaling of the analogue value for volumetric flow

<ul style="list-style-type: none"> ▶ Select [OU2] and set the function: [I] = current signal proportional to volumetric flow (4...20 mA); ▶ Select [ASP] and set the value at which the minimum output value is provided. ▶ Select [AEP] and set the value at which the maximum output value is provided. 	
--	---

9.3 Settings for monitoring of consumed quantities

9.3.1 Settings for quantity monitoring by pulse output

<ul style="list-style-type: none"> ▶ [Select [OU1] and set [ImP]. ▶ Select [ImPS] and set the volumetric flow quantity at which 1 pulse is provided (→ 9.6). ▶ Select [ImPR] and set [YES] > Pulse repetition is active. Output 1 provides a counting pulse when the value set in [ImPS] is reached. 	
---	---

9.3.2 Settings for quantity monitoring using the preset meter

<ul style="list-style-type: none"> ▶ Select [OU1] and set [ImP]. ▶ Select [ImPS] and set the volumetric flow quantity at which output 1 switches (→ 9.6). ▶ Select [ImPR] and set [no] > Pulse repetition is not active. The output switches ON if the value set in [ImPS] is reached. It remains switched until the meter is reset. 	
---	---

9.3.3 Settings for meter reset controlled by the program

<ul style="list-style-type: none"> ▶ Select [rTo] and continue with a) or b). a) Reset the meter manually ▶ Press [Set] until [rES.T] is displayed, then press [Mode/Enter] briefly. b) Enter the value for time-controlled reset ▶ Press [Set] until the requested value is displayed (intervals from 1 hour to 8 weeks), then press [Mode/Enter] briefly. 	
--	---

9.3.4 Switch off the meter reset

- ▶ Select [rTo] and set [OFF]. The meter is only reset after overflow (= factory setting).

rTo

9.4 User settings (optional)

9.4.1 Determine the standard unit of measurement for volumetric flow

- ▶ Select [Uni] and set the unit of measurement:
 - [Lmin] = flow rate in standard litres / minute.
 - [nm3h] = flow rate in standard cubic metres / hour.The setting only has an effect on the volumetric flow value. The counter values (consumed quantity) are automatically displayed in the unit of measurement providing the highest accuracy.

Uni

UK

9.4.2 Configuration of the standard display

- ▶ Select [SELD] and determine the standard process category.
 - [FLOW] = display shows the current volumetric flow value in the standard unit of measurement.
 - [TOTL] = display indicates the current meter count in Nm³ or 1000 Nm³.
- ▶ Select [diS] and determine the update rate and orientation of the display:
 - [d1] = update of the measured values every 50 ms.
 - [d2] = update of the measured values every 200 ms.
 - [d3] = update of the measured values every 600 ms.
 - [rd1], [rd2], [rd3] = display as for d1, d2, d3; rotated by 180°.
 - [OFF] = the display is switched off in the operating mode.

SELD
diS

9.4.3 Setting the damping of the measured values

- ▶ Select [dAP] and the damping constant in seconds (t value 63 %).

dAP

9.4.4 Setting the error behaviour of OUT1 / OUT2

- ▶ [Select [FOU1] and determine the value:
 - [On] = output 1 switches ON in case of an error.
 - [OFF] = output 1 switches OFF in case of an error.
 - [OU] = output 1 switches irrespective of the error as defined with the parameters.
- ▶ Select [FOU2] and determine the value:
 - [On] = output 2 switches ON in case of an error, the analogue signal goes to the upper end stop value.
 - [OFF] = output 2 switches OFF in case of an error, the analogue signal goes to the lower end stop value.
 - [OU] = output 2 switches irrespective of the error as defined with the parameters. The analogue signal corresponds to the measured value.

FOU1
FOU2

9.4.5 Selection of the medium to be monitored

<p>▶ Select [MEDI] and determine the required medium:</p> <ul style="list-style-type: none">- [Ar] = argon.- [CO2] = carbon dioxide.- [N2] = nitrogen. <p>Changing to another medium modifies the set limit values for switching signals and the analogue signal. Therefore select the medium before you define the values for the parameters SPx, rPx, ASP and AEP.</p>	
--	---

9.5 Service-Funktionen

9.5.1 Reading the min./max. values for volumetric flow

<p>▶ Select [HI] or [LO] and press [Set] briefly. [HI] = maximum value, [LO] = minimum value.</p> <p>Delete memory:</p> <p>▶ Select [HI] or [LO].</p> <p>▶ Press [Set] and keep it pressed until [----] is displayed.</p> <p>▶ Press [Mode/Enter] briefly.</p> <p>It makes sense to delete the memories as soon as the unit works under normal operating conditions for the first time.</p>	
---	---

9.5.2 Reset all parameters to the factory setting

<p>▶ Select [rES], then press [Set] and keep it pressed until [----] is displayed.</p> <p>▶ Press [Mode/Enter] briefly.</p> <p>The factory setting is listed at the end of the instructions (→ 13 Factory setting).</p> <p>It makes sense to write your own settings in this table before executing the function.</p>	
---	---

9.6 Setting of the preset meter / pulse value (ImPS)

7 setting ranges are available:

	LED	indication	in steps of	value										
1	3	<table border="1"><tr><td>0</td><td>.</td><td>0</td><td>0</td><td>1</td></tr></table> ... <table border="1"><tr><td>9</td><td>.</td><td>9</td><td>9</td><td>9</td></tr></table>	0	.	0	0	1	9	.	9	9	9	0.001 Nm ³	0.001...9.999 Nm ³
0	.	0	0	1										
9	.	9	9	9										
2	3	<table border="1"><tr><td>1</td><td>0</td><td>.</td><td>0</td><td>0</td></tr></table> ... <table border="1"><tr><td>9</td><td>9</td><td>.</td><td>9</td><td>9</td></tr></table>	1	0	.	0	0	9	9	.	9	9	0.01 Nm ³	10.00...99.99 Nm ³
1	0	.	0	0										
9	9	.	9	9										
3	3	<table border="1"><tr><td>1</td><td>0</td><td>0</td><td>.</td><td>0</td></tr></table> ... <table border="1"><tr><td>9</td><td>9</td><td>9</td><td>.</td><td>9</td></tr></table>	1	0	0	.	0	9	9	9	.	9	0.1 Nm ³	100.0...999.9 Nm ³
1	0	0	.	0										
9	9	9	.	9										
4	3	<table border="1"><tr><td>1</td><td>0</td><td>0</td><td>0</td><td></td></tr></table> ... <table border="1"><tr><td>9</td><td>9</td><td>9</td><td>9</td><td></td></tr></table>	1	0	0	0		9	9	9	9		1 Nm ³	1000...9999 Nm ³
1	0	0	0											
9	9	9	9											
5	3 + 5	<table border="1"><tr><td>1</td><td>0</td><td>.</td><td>0</td><td>0</td></tr></table> ... <table border="1"><tr><td>9</td><td>9</td><td>.</td><td>9</td><td>9</td></tr></table>	1	0	.	0	0	9	9	.	9	9	10 Nm ³	10 000...99 990 Nm ³
1	0	.	0	0										
9	9	.	9	9										
6	3 + 5	<table border="1"><tr><td>1</td><td>0</td><td>0</td><td>.</td><td>0</td></tr></table> ... <table border="1"><tr><td>9</td><td>9</td><td>9</td><td>.</td><td>9</td></tr></table>	1	0	0	.	0	9	9	9	.	9	100 Nm ³	100 000...999 900 Nm ³
1	0	0	.	0										
9	9	9	.	9										
7	3 + 5	<table border="1"><tr><td>1</td><td>0</td><td>0</td><td>0</td><td></td></tr></table>	1	0	0	0			1 000 000 Nm ³					
1	0	0	0											

UK

Setting operation:

- ▶ Ensure that [OU1] is set to [ImP].
- ▶ Select [ImPS], press [Set] and keep it pressed.
- > The current numerical value flashes for 5 s, then one of the 4 digits becomes active (digit flashes, can be changed).
- ▶ Set the requested value as indicated in the following table.
First select the requested setting range. Then set the figure from the left digit to the right digit.
- ▶ Press [Mode/Enter] briefly when all 4 digits are set.

As soon as the first digit flashes there are 3 options:

▶ Press [Set] once	<p>The flashing digit is increased. 9 is followed by 0 - 1 - 2, etc.</p> <table style="margin-left: auto; margin-right: auto;"> <tr> <td></td> <td style="border: 1px solid black; padding: 2px;">8</td> <td style="border: 1px solid black; padding: 2px;">.</td> <td style="border: 1px solid black; padding: 2px;">1</td> <td style="border: 1px solid black; padding: 2px;">2</td> <td style="border: 1px solid black; padding: 2px;">3</td> </tr> <tr> <td>[Set] pressed 1 x</td> <td style="border: 1px solid black; padding: 2px;">9</td> <td style="border: 1px solid black; padding: 2px;">.</td> <td style="border: 1px solid black; padding: 2px;">1</td> <td style="border: 1px solid black; padding: 2px;">2</td> <td style="border: 1px solid black; padding: 2px;">3</td> </tr> <tr> <td>[Set] pressed 1 x</td> <td style="border: 1px solid black; padding: 2px;">0</td> <td style="border: 1px solid black; padding: 2px;">.</td> <td style="border: 1px solid black; padding: 2px;">1</td> <td style="border: 1px solid black; padding: 2px;">2</td> <td style="border: 1px solid black; padding: 2px;">3</td> </tr> <tr> <td>[Set] pressed 1 x</td> <td style="border: 1px solid black; padding: 2px;">1</td> <td style="border: 1px solid black; padding: 2px;">.</td> <td style="border: 1px solid black; padding: 2px;">1</td> <td style="border: 1px solid black; padding: 2px;">2</td> <td style="border: 1px solid black; padding: 2px;">3</td> </tr> </table>		8	.	1	2	3	[Set] pressed 1 x	9	.	1	2	3	[Set] pressed 1 x	0	.	1	2	3	[Set] pressed 1 x	1	.	1	2	3
	8	.	1	2	3																				
[Set] pressed 1 x	9	.	1	2	3																				
[Set] pressed 1 x	0	.	1	2	3																				
[Set] pressed 1 x	1	.	1	2	3																				

<p>► Press [Set] and keep it pressed.</p>	<p>The flashing digit is increased, 9 is followed by 0 and the first new digit (left) becomes active.</p> <p style="text-align: right;">8 .1 8 3</p> <p style="text-align: right;">[Set] permanently pressed 8 .1 9 3</p> <p style="text-align: right;">[Set] kept pressed 8 .1 0 3</p> <hr/> <p>If digit 1 is increased this way, the display changes to the next higher setting range (9 is followed by 10).</p> <p style="text-align: right;">8 .1 2 3</p> <p style="text-align: right;">[Set] permanently pressed 9 .1 2 3</p> <p style="text-align: right;">[Set] kept pressed 1 0 .1 2</p>
<p>► Press no pushbutton for 3 s.</p>	<p>The digit following on the right flashes (= becomes active). If the fourth digit flashes unchanged for 3 s, digit 1 becomes active again (if the value of digit 1 is > 0).</p> <p style="text-align: right;">8 .1 2 3</p> <p style="text-align: right;">no pushbutton pressed; after 3 s 8 .1 2 3</p> <p style="text-align: right;">after 3 s 8 .1 2 3</p> <p style="text-align: right;">after 3 s 8 .1 2 3</p> <p style="text-align: right;">after 3 s 8 .1 2 3</p> <hr/> <p>If digit 1 has the value "0", the display changes to the next lower setting range.</p> <p style="text-align: right;">0 1 .2 3</p> <p style="text-align: right;">no pushbutton pressed; after 3 s 0 1 .2 3</p> <p style="text-align: right;">after 3 s 0 1 .2 3</p> <p style="text-align: right;">after 3 s 0 1 .2 3</p> <p style="text-align: right;">after 3 s (new digit 4 active and set to 0) 1 .2 3 0</p> <p style="text-align: right;">after 3 s (new digit 1 active) 1 .2 3 0</p>

Highlighted grey (1) = flashing digit

Note: If [Set] is pressed continuously, the display moves through all setting ranges; after the end value it jumps back to the start value. Release [Set] briefly and start the setting again.

10 Operation

Correct operation and compliance with the measurement accuracy can only be ensured if the environmental conditions specified in the “Technical data” (→ chapter 12) are adhered to. Ensure that the maximum pressure range, measuring range and permitted operating temperature are not exceeded.

After power on and expiry of the power-on delay time (approx. 0.5 s) the unit is in the Run mode (= normal operating mode). It carries out its measurement and evaluation functions and generates output signals according to the set parameters.

- Operation indication → chapter 7 Controls and indicating elements.
- During the power-on delay time the outputs are switched as programmed: ON for NO function (Hno / Fno) and OFF for NC function (Hnc / Fnc).
- If output 2 is configured as analogue output, the output signal is at the maximum value during the power-on delay time.

UK

10.1 Read the set parameters

- ▶ Press [Mode/Enter] until the requested parameter is displayed.
- ▶ Press [Set] briefly.
- > The unit displays the corresponding parameter value for about 15 s. After another 15 s the parameter is displayed again, then the unit returns to the Run mode.

10.2 Changing the display unit in the Run mode

- ▶ Press [Set] briefly in the Run mode. Press the pushbutton to move to the next display unit.
- > The unit displays the current measured value for approx. 15 s, the corresponding LED lights.

10.3 Error indication

[SC1]	Short circuit in OUT1.*
[SC2]	Short circuit in OUT2.*
[SC]	Short circuit in both outputs.*
[OL]	Measured value > 120% of the final value of the measuring range.
[UL]	Measured value < lowest value of the measuring range.
[Err]	Fault in the measuring probe.

*The output concerned is switched off as long as the short circuit continues. These faults are indicated even if the display is deactivated.

10.4 General operating conditions

The unit is maintenance-free for media which will not adhere to the measuring probes.

- From time to time check the measuring probes visually for build-up.
- If necessary, clean them at regular intervals. To do so, use a suitable cleaning liquid (e.g. alcoholic solution).
- Avoid mechanical damage to the measuring probes.

11 Scale drawing

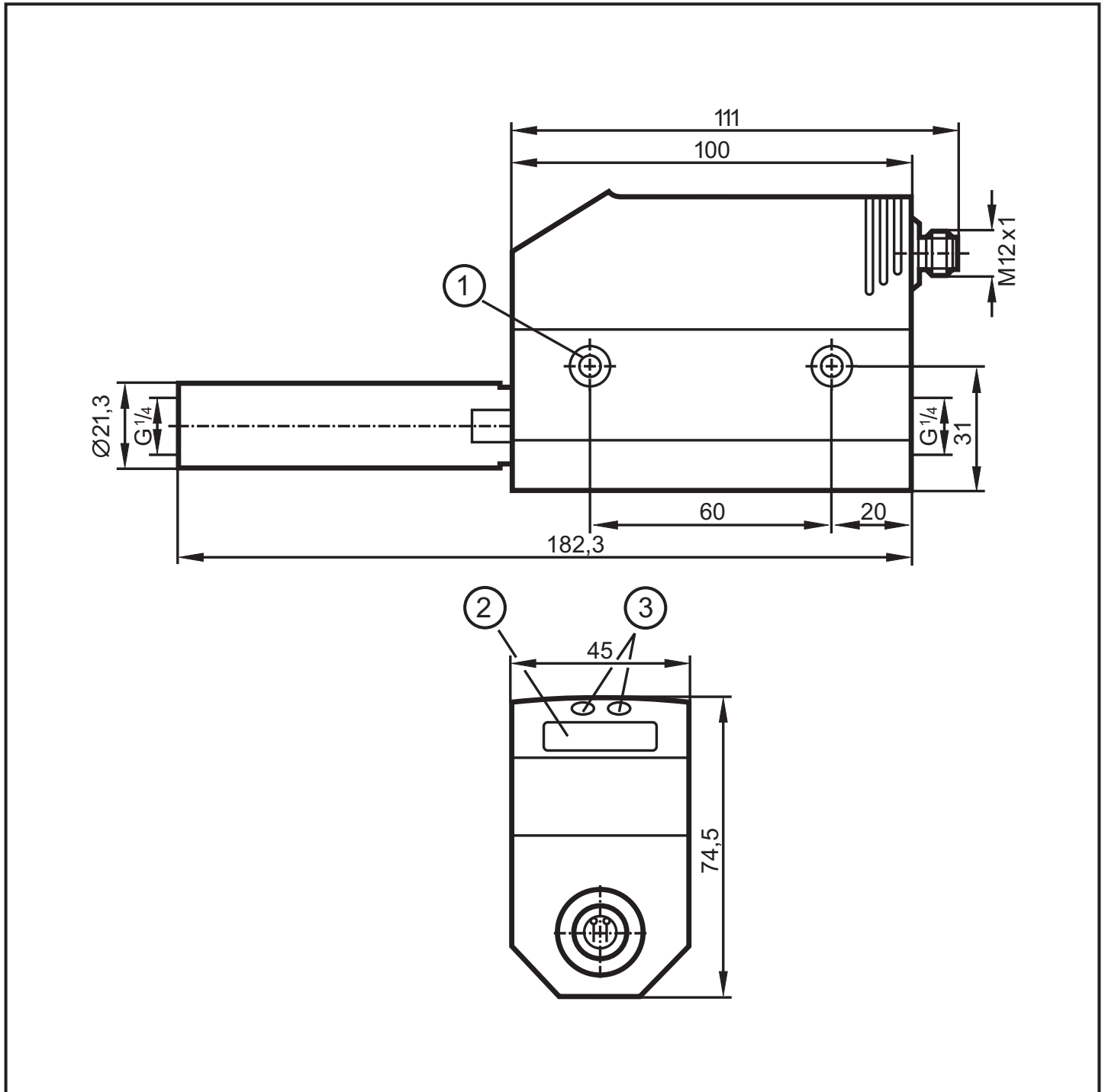

Dimensions are in millimeters

1: Programming pushbuttons; 2: Alphanumeric display; 3: LED

12 Technical data

Operating voltage [V].....	19...30 DC to EN50178, SELV, PELV
Current rating [mA]	2 x 250
Protection: short circuit, reverse polarity, overload	
Voltage drop [V]	< 2
Current consumption typ. [mA]	100
Analogue output	4...20 mA; measuring range scaleable
Max. load [Ω]	500
Pulse value	0.001...1 000 000 m ³
Pulse length [s]	min. 0.122 / max. 2
Power-on delay time [s]	0.5

Flow monitoring

		l/min	m ³ /h
Measuring range *	Ar	1.36 (1.5)...409.0	0.08...24.54
	CO ₂	0.79 (1.0)...239.6	0.047 (0.04)...14.38
	N ₂	0.83 (1.0)...248.8	0.05 (0.06)...14.94
Display range	Ar	0.0...490.7	0.00...29.44
	CO ₂	0.0...287.3	0.00...17.24
	N ₂	0.0...298.7	0.00...17.92

* in brackets: displayed value

Measuring error (under conditions acc. to DIN ISO 2533 and when installed in DN8 pipes) ± (6% of the measured value + 0.6% of the final value of the measuring range)	
Repeatability [% of the measured value]	± 1.5
Measurement dynamics	1:300
Response time [s]	< 0.1 (dAP = 0)

Temperature indication

Measuring range [°C]	0...60
Measuring error * [°C]	2

* for medium flow in the limit area of the flow measurement range

UK

Operating temperature [°C]	0...60
Medium temperature [°C]	0...60 (rel. humidity: max. 90%)
Storage temperature [°C]	-25...85
Pressure resistance [bar]	16
Material (wetted parts)	stainless steel (304S15); ceramics glass passivated; PEEK; polyester; Viton; aluminium anodised
Housing materials	stainless steel (304S15), Viton; PBT-GF 20, PC (APEC); Makrolon
Protection	IP 65 / III
Vibration resistance [g]	5 (DIN / IEC 68-2-6, 55 - 2000 Hz)
EMC IEC 1000/4/2 ESD:	4 / 8 KV
IEC 1000/4/3 HF radiated:	10 V/m
IEC 1000/4/4 Burst:	2 KV
IEC 1000/4/6 HF conducted:	10 V

All data refer to standard volume flow according to DIN ISO 2533.

12.1 Setting ranges

NI/min	SP1 / SP2		rP1 / rP2		ASP		AEP		ΔQ
	min	max	min	max	min	max	min	max	
Ar	3.0	409.0	1.0	407.0	0.0	307.0	102.5	409.0	0.5
CO2	1.8	239.6	0.6	238.4	0.0	179.6	59.8	239.6	0.2
N2	1.8	248.8	0.6	247.6	0.0	186.6	62.2	248.8	0.2

Nm³/h	SP1 / SP2		rP1 / rP2		ASP		AEP		ΔQ
	min	max	min	max	min	max	min	max	
Ar	0.18	24.54	0.06	24.42	0.00	18.40	6.14	24.54	0.02
CO2	0.10	14.38	0.02	14.30	0.00	10.78	3.58	14.38	0.02
N2	0.10	14.94	0.02	14.86	0.00	11.20	3.72	14.94	0.02

ImPS	min	max
	0.001 Nm³	1 000 000 Nm³

(ΔQ = step increment)

13 Factory setting

	Factory setting	User setting
SP1	4.90	
rP1	8.78	
ImPS	0.001	
ImPR	YES	
OU1	Hno	
OU2	Hno	
SP2	9.82	
rP2	9.68	
ASP	0.00	
AEP	24.54	
FOU1	OFF	
FOU2	OFF	
dAP	0.6	
rTo	OFF	
diS	d3	
Uni	nm3h	
SELd	FLOW	
MEDI	Ar	

UK

More information at www.ifm.com