

**THE
BALL
DON'T
LIE.®**

CONTENTS

1. GETTING STARTED

What's in The Box

Explore The App

Activating Your Ball For The First Time

Download the Free 94Fifty App

Setting Up Players

Starting an Activity

Ball Settings

2 CHARGING & POWER MANAGEMENT

Charging Your Ball

3 TIPS FOR BALL CARE & TROUBLESHOOTING

Extending the Life of Your 94Fifty Smart Sensor Basketball

Troubleshooting

4 WARRANTY & LEGAL

Warranty

Legal

Getting Started

1

WHAT'S IN THE BOX

- 1 Ball
- 2 Wireless Charging Pad
- 3 Detachable Ball Holder
- 4 Power Cord

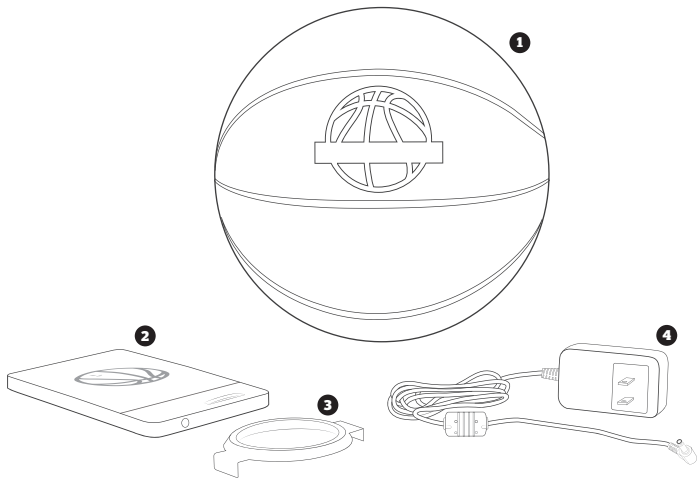

EXPLORE THE APP



My Dashboard

- View widgets that give you suggestions and data related to your game.



Skill Training

- Build your ball handling and shooting skills on your own time. You pick the drill, 94Fifty will count.



Workout

- The app adjusts as you improve and increases skill difficulty from playground up to pro level.



Head to Head

- Automated, real-time scoring and leaderboards determine the winner for up to five players.



Social Challenge

- Show the world that you've been working on your game by challenging and sharing with your friends via social media.



Player Settings

- Edit the primary player's information, social settings, squad settings and history.



Ball Settings

- Name your ball, manage travel mode, and confirm firmware versions in one place.

Your 94Fifty Smart Sensor Basketball is delivered to you in Travel Mode to ensure a fresh battery. To unlock Travel Mode, follow the instructions below to activate your ball. **This process only needs to be done once before using the ball for the first time.**

ACTIVATING YOUR BALL FOR THE FIRST TIME

Step 1: Connect Wireless Charging Pad to Power Cord as shown

Step 2: Connect Power Cord into power outlet. The blue light on the Wireless Charging Pad should blink once.

Step 3: Place the ball onto the Wireless Charging Pad by aligning the “Ball Logo” on the basketball with the “Ball Logo” on the Wireless Charging Pad. The light on the Wireless Charging Pad will turn **solid blue** when activation is complete.

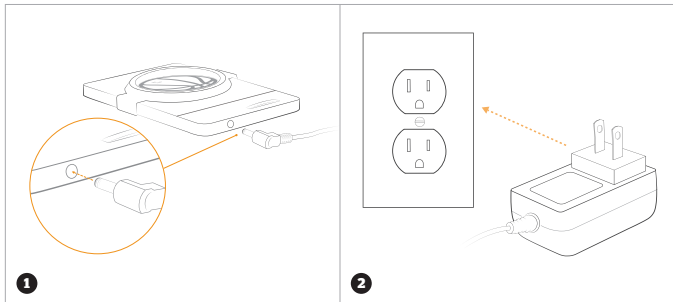

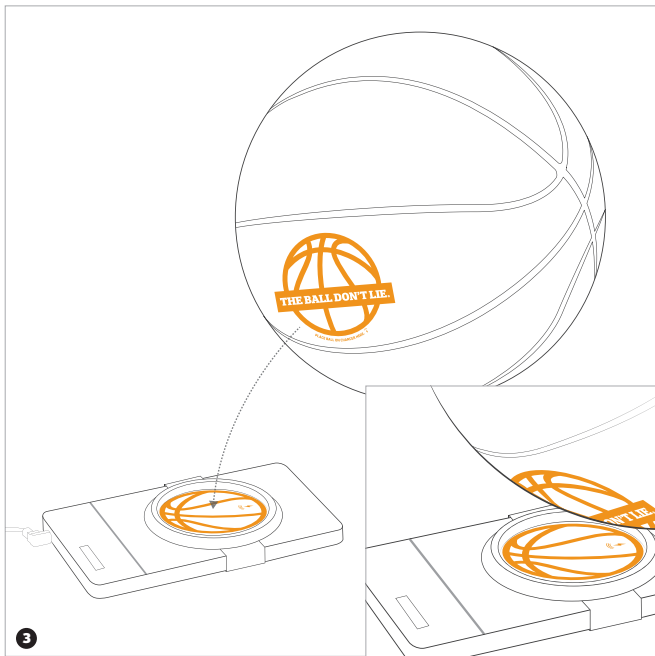

DOWNLOAD THE FREE 94FIFTY APP

Visit the App Store or Google Play and search for 94Fifty.



Compatible with iOS devices that support Bluetooth 4.0.

For a full list of compatible devices visit 94Fifty.com/devices

SETTING UP PLAYERS



PRIMARY PLAYER

Upon launching the app, you will be prompted to sign in or create an account for the primary user. If a social media account is linked to your device, you will have the option to set up the primary account with the listed social media accounts. If you do not have a social media account, you can create a 94Fifty account. An internet connection is required to sign in with these accounts.

DO I NEED TO BE CONNECTED TO THE INTERNET?

-When first launching the app, you must have internet connection to sign in. After signing in, no internet connection is needed unless you want to compete with friends and participate in the Global 94Fifty Community.

-If you do not have access to the internet, you can always select the **“Just Visiting”** to play with your 94Fifty Smart Sensor Basketball.



YOUR SQUAD

The primary player account includes the option to store up to 3 additional players and their history on your device. You will also have the option to add 1 guest to an activity. Guest history will not be saved. Manage Your Squad in the “**Player Settings**” section in the app.

STARTING AN ACTIVITY

At any time an **orange** screen appears, the app will wait for you to begin. The app will provide activity instructions and goals.



SHOOTING *At least 2 Players Recommended*

For the app to recognize the shot, **it must be a chest pass to the shooter.** When you start shooting, 94Fifty starts counting.

ARE YOU BY YOURSELF?

- A quick tip if you are shooting by yourself ... spin the ball into the air – catch it – and shoot. Be sure not to let the ball hit the ground before shooting.

BALL HANDLING +

Bouncing the ball will begin any dribbling drill. When you start dribbling, 94Fifty starts counting.

DO I NEED TO WORRY ABOUT TURNING MY BALL ON AND OFF?

- The ball turns on after bouncing it four times in a row when prompted. This keeps it from turning on when it's in your bag and makes it available only when you need it.
- To conserve battery life, the ball **automatically** enters sleep mode after inactivity

BALL SETTINGS

NAMING YOUR BALL

Personalize your 94Fifty Smart Sensor Basketball by giving it a name that is then displayed across any device. To add or edit your ball name, select **“Ball Settings”** from the main navigation drawer, connect your ball when prompted and select **“Edit”** in the top-right corner.

TRAVEL MODE

Turn on travel mode before air travel or to disable wireless communications. To turn on travel mode, select **“Ball Settings”** from the main navigation drawer, connect your ball when prompted and select **“Edit”** in the top-right corner. **Warning!** Travel mode locks the ball and requires the Wireless Charging Pad to re-activate the ball. When putting a ball into travel mode, be sure to bring your Wireless Charging Pad with you.

Charging & Power Management

2

CHARGING YOUR BALL

BEFORE YOU CONNECT TO THE CHARGING PAD ...

Be sure the Detachable Ball Holder is slid onto the Wireless Charging Pad if not done so already. Be sure that the Ball Holder is positioned so that the "Ball Logo" on the Charging Pad is fully visible through the center of the Ball Holder. (See below)

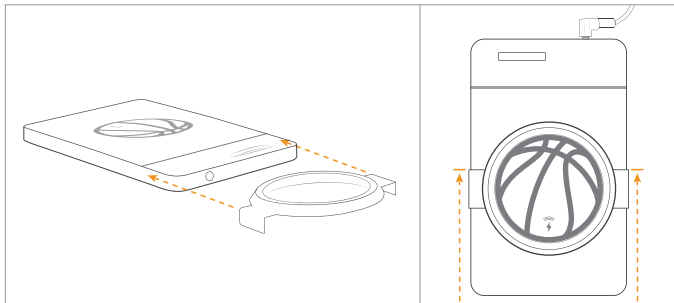

NOTE: *The 94Fifty Smart Sensor Basketball is designed to be used specifically with the 94Fifty Qi Compatible Wireless Charging Pad. We do not warrant the use of any other unapproved device. You may, however, use the 94Fifty Wireless Charging Pad to charge any other Qi compatible device.*

Step 1: Connect Wireless Charging Pad to Power Cord

Step 2: Connect Power Cord into power outlet. The blue light on the Wireless Charging Pad should blink once.

Step 3: Place the ball onto the Wireless Charging Pad by aligning the “Ball Logo” on the Basketball with the “Ball Logo” on the Wireless Charging Pad.

Charging Status

Charging - The blue light on the Wireless Charging Pad will turn **solid blue** when charging. A dead battery will take about 3 hours to “fully charge.” The app will let you know when your battery is getting low.

Fully Charged - The blue light on the Wireless Charging Pad will blink when fully charged. There is no damage to the battery if the ball is left on the Wireless Charging Pad.

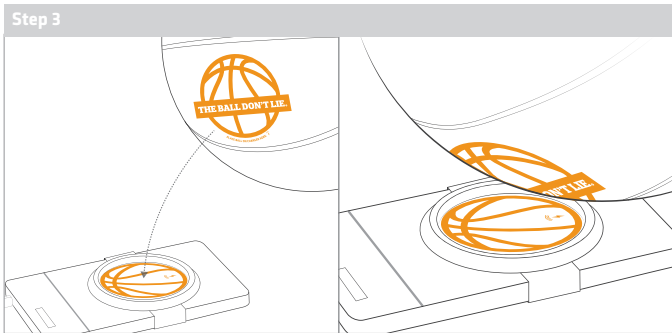



Tips For Ball Care & Troubleshooting

3

EXTENDING THE LIFE OF YOUR BASKETBALL

The 94Fifty Smart Sensor Basketball contains a rugged, durable outer layer designed for indoor and outdoor use. Obviously, any ball used outdoors will show wear more quickly than with indoor use. The bottom line is that the more you play outdoors, and the rougher the surface of the play area, the faster the outer skin will lose its grip.

Here are a few tips for extending the life of your investment:

- Use it indoors when you can, particularly in inclement weather.
- Don't leave it outside when you are finished playing. Remember – it is just like your mobile phone or iPod – neither of which you would leave outside.
- Charge the battery regularly. Like any battery, the less you use it, the less effective it becomes over time.
- Do not place or leave the ball in water. While the ball is water resistant, it is not waterproof. If you leave it in the water (pool, rain, puddles, sink, bathtub, ocean, etc.) you will ruin the skin and the electronics. The warranty will be voided.
- Avoid kicking or throwing the ball against a wall. It is very rugged, but it is not a baseball. No matter how frustrated you get, don't do it. We consider this to be abnormal use of the ball. This is misuse and will void the warranty. Instead, kick a soccer ball or football to blow off some steam.
- Do not to freeze the ball. While it won't fit in your freezer, it can fit in your garage. In some places, garages can freeze.
- Do not leave your ball unattended in public places. We do not warrant against theft. It might happen. So when using your ball, watch it closely and keep it close to you. If it gets stolen, there is no mechanism to track its location.

TROUBLESHOOTING

BALL WON'T CONNECT TO APP AFTER BOUNCING.

- Try charging the battery in the Ball. The ball may have low or no battery charge and is no longer able to communicate with the app. To charge the ball, place it on the Wireless Charging Pad (refer to page 13) and confirm that the blue light turns on. If the blue light on the Wireless Charging Pad turns on, then the ball is receiving a charge. Let the ball charge for at least 1 hour before reconnecting.
- Confirm that you are not in travel mode. If you had the ball set to travel mode to conserve power, you will need to place the ball on the Wireless Charging Pad for a few seconds to re-activate the ball. (refer to page 6 and 7)
- After activating the ball (indicated by the blue light on the Wireless Charging Pad), bounce the ball until the ball connects.
- Confirm that the Bluetooth radio on your mobile device is on. Refer to your mobile device manual or instructions for turning on your Bluetooth radio.
- Are you using an approved and compatible device? (refer to page 8)
- If the ball still does not connect after steps 1-4, then visit www.94Fifty.com/support.

PERFORMANCE DATA APPEARS TO HAVE DISAPPEARED.

- The app records and stores data for up to 4 players for a maximum of three months. Data older than three months is automatically removed from the app. To store data for longer than three months, you can subscribe to the 94Fifty online community for a monthly fee. Log into community.94Fifty.com with the username and password on your app to learn more.

WIRELESS CHARGING PAD LIGHT DOES NOT TURN BLUE WHEN BALL IS PLACED ON PAD.

- Confirm that the Wireless Charging Pad is properly connected to the AC power cord and plugged into a power outlet.
- To test that the Wireless Charging Pad is working properly, first disconnect the AC power cord from the power outlet and reconnect. After reconnecting, the blue light on the Wireless Charging Pad should blink once. If this does not occur, then confirm all steps again before visiting www.94Fifty.com/support.
- Confirm that the logo on the ball is matched to the logo on the Wireless Charging Pad (refer to page 15). A blue light should appear when the ball is placed properly on to the Wireless Charging Pad.
- If the blue light still does not appear after Step 3, contact customer service at www.94Fifty.com/support.

THE APP UNEXPECTEDLY CLOSED DURING USE AND RETURNED TO THE MOBILE DEVICE HOME SCREEN.

- Restart the app and try again.
- If this condition persists then contact www.94Fifty.com/support.

Warranty & Legal

4

InfoMotion Sports Technologies Inc. (IST)

© Infomotion Sports Technologies Inc. All rights reserved

Under the copyright laws, this manual may not be copied, in whole or in part, without the consent of IST.

Every effort has been made to ensure that the information in this manual is accurate. IST is not responsible for printing or clerical errors.

InfoMotion Sports Technologies Inc.

6625 Dublin Center Dr.

Dublin, OH 43017

508-463-3601

www.infomotionsports.com

www.94Fifty.com

InfoMotion, 94Fifty, and the Ball Don't Lie are registered trademarks of InfoMotion Sports Technologies Inc. registered in the U.S. and other countries. Use of any mark or trademark without the prior written consent of InfoMotion Sports Technologies may constitute trademark infringement and unfair competition in violation of federal and state laws.

INFOMOTION SPORTS TECHNOLOGIES 94FIFTY SMART SENSOR BASKETBALL AND WIRELESS CHARGING PAD LIMITED WARRANTY

This warranty gives you specific legal rights and you may also have other rights which vary from state to state.

WARRANTY

InfoMotion Sports Technologies Inc. ("InfoMotion") warrants that any InfoMotion Sensor Basketball ("Basketball"), as well as any InfoMotion Wireless Charging Pad ("Charging Pad"), will be free of defects in material and/or workmanship for one year from the date of purchase ("Limited Warranty Period"). You will be required to provide valid proof of purchase (including purchase date) in order to receive warranty service.

For purposes of illustration, but not limitation, the following are not defects in material or workmanship: (a) cosmetic damage (nicks, bruising, discoloration); (b) normal wear and tear; (c) damage resulting from or related to misuse, unauthorized modification or alteration, accident, water, acts of God, external causes; (d) consumables (such as batteries); (e) damage caused by electricity surges, use with improper voltage or power supply; (f) wireless signal interruption or errors in data transmission; (g) failure to use and/or maintain the Basketball and Charging Pad in conjunction with the instructions contained in the Instruction Manual; (h) damage caused by service (including upgrades and expansions) performed by anyone who is not a representative of InfoMotion; and (i) recovery and reinstallation of software programs and user data.

InfoMotion makes no warranty as to any InfoMotion software and iPhone software application (collectively "InfoMotion IT"), including but not limited to any warranty that the InfoMotion IT will be bug-free, error-free or will run without interruption.

LIMITED REMEDIES

If the Basketball or Charging Pad fails because of a defect in material and/or workmanship during the Limited Warranty Period, InfoMotion shall, in its sole discretion, either (1) repair the defective Basketball or Charging Pad or (2) replace the Basketball or Charging Pad with a new Basketball or Charging Pad. InfoMotion's repair or replacement shall be made at no cost for labor or parts. However, you shall be responsible for and must prepay all shipping or transportation charges associated with the warranty service. Additionally, you shall assume all risk of loss or damage to the Basketball and Charging Pad until receipt by InfoMotion. In the event of a defect, to the extent permitted by law, these are your sole and exclusive remedies.

IMPLIED WARRANTY OF MERCHANTABILITY AND/OR FITNESS FOR PARTICULAR PURPOSE DISCLAIMER

EXCEPT WHERE PROHIBITED BY LAW, THIS WARRANTY IS EXCLUSIVE AND THE ONLY WARRANTY APPLICABLE TO THE BASKETBALL, THE CHARGING PAD AND INFOMOTION IT. IT IS OFFERED EXPRESSLY IN LIEU OF ANY OTHER WARRANTIES, EXPRESS OR IMPLIED, INCLUDING ANY IMPLIED WARRANTY OF MERCHANTABILITY OR FITNESS FOR A PARTICULAR PURPOSE, ALL OF WHICH ARE DISCLAIMED.

To the extent a state or jurisdiction prohibits the disclaimer of implied warranties, such implied warranties are limited to the Limited Warranty Period.

INCIDENTAL AND CONSEQUENTIAL DAMAGE DISCLAIMER

EXCEPT WHERE PROHIBITED BY LAW, INFOMOTION DISCLAIMS AND UNDER NO CIRCUMSTANCES SHALL BE LIABLE FOR SPECIAL, INCIDENTAL, INDIRECT OR CONSEQUENTIAL DAMAGES OR LOSSES RESULTING FROM THE USE, MISUSE, OR INABILITY TO USE THE BASKETBALL OR CHARGING PAD AS WELL AS ANY BREACHES OF THIS WARRANTY OR ANY IMPLIED WARRANTY REGARDLESS OF THE CAUSE AND EVEN IF THE CLAIMED DAMAGES OR LOSSES WERE CAUSED BY A WARRANTABLE DEFECT.

BY WAY OF ILLUSTRATION, BUT NOT EXHAUSTION, PRECLUDED DAMAGES INCLUDE LOSS OF PROFITS, LOSS OF REVENUE, LOSS OF USE OF THE BASKETBALL OR CHARGING PAD, DOWNTIME COSTS OR CLAIMS OF CUSTOMER'S CUSTOMERS, WHETHER BASED ON CONTRACT, TORT (INCLUDING STRICT LIABILITY OR NEGLIGENCE) OR OTHERWISE, EVEN IF ADVISED OF THE POSSIBILITY OF SUCH DAMAGES.

IN NO EVENT SHALL INFOMOTION'S LIABILITY EXCEED THE SELLING PRICE FOR THE BASKETBALL AND CHARGING PAD.

STATE SPECIFIC LAWS

Note, some states do not allow limitations on how long an implied warranty will last or the exclusion or limitation of incidental or consequential damages, so the above limitations or exclusions may not apply to you.

MODIFICATIONS/ALTERATIONS

No InfoMotion reseller, agent, or employee is authorized to make any modification, extension, or addition to this Limited Warranty.

UNENFORCEABILITY

If any term is held to be illegal or unenforceable, the legality or enforceability of the remaining terms shall not be affected or impaired.

OBTAINING WARRANTY SERVICE

To obtain warranty service on your Basketball or Charging Pad, you must have valid proof of purchase:

- Visit www.94Fifty.com/warranty for more details

GOVERNING LAW

This Limited Warranty shall be governed by the laws of the State of Ohio without giving effect to any conflict of laws principles that may provide the application of the law of another jurisdiction.

REGULATORY AND COMPLIANCE

Changes or modifications not expressly approved by the party responsible for compliance could void the user's authority to operate the equipment.

This device complies with Part 15 of the FCC Rules. Operation is subject to the following two conditions: (1) this device may not cause harmful interference, and (2) this device must accept any interference received, including interference that may cause undesired operation.

This equipment has been tested and found to comply with the limits for a Class B digital device, pursuant to Part 15 of the FCC Rules. These limits are designed to provide reasonable protection against harmful interference in a residential installation. This equipment generates, uses and can radiate radio frequency energy and, if not installed and used in accordance with the instructions, may cause harmful interference to radio communications. However, there is no guarantee that interference will not occur in a particular installation.

If this equipment does cause harmful interference to radio or television reception, which can be determined by turning the equipment off and on, the user is encouraged to try to correct the interference by one or more of the following measures:

- Reorient or relocate the receiving antenna.
- Increase the separation between the equipment and receiver.
- Connect the equipment into an outlet on a circuit different from that to which the receiver is connected.
- Consult the dealer or an experienced radio/TV technician for help.

This device complies with Industry Canada license-exempt RSS standard(s). Operation is subject to the following two conditions: (1) this device may not cause interference, and (2) this device must accept any interference, including interference that may cause undesired operation of the device.

Le présent appareil est conforme aux CNR d'Industrie Canada applicables aux appareils radio exempts de licence. L'exploitation est autorisée aux deux conditions suivantes : (1) l'appareil ne doit pas produire de brouillage, et (2) l'utilisateur de l'appareil doit accepter tout brouillage radioélectrique subi, même si le brouillage est susceptible d'en compromettre le fonctionnement.

This Class[B] digital apparatus complies with Canadian ICES-003.

Cet appareil numérique de la classe B est conforme à la norme

NMB-003 du Canada.

GET YOUR GAME ON.