



SPILL PROOF • SPILL PROOF CUTS

Service Manual



First Edition: August 2002
Last Revision: April 2013
Document # 720003-0000



Legal Notices

Disclaimer

Information in this document is subject to change without notice. Consult your Nanoptix Inc. sales representative for information that is applicable and current. Nanoptix Inc. reserves the right to improve products as new technology, components, software and firmware become available.

No part of this document may be reproduced or transmitted in any form or by any means, electronic or mechanical, for any purpose without the express written permission of Nanoptix Inc.

Copyright

Copyright 2008 by Nanoptix Inc.
Dieppe, New Brunswick Canada
All rights reserved
Printed in Canada
Confidential, Unpublished
Property Of. Nanoptix Inc.

Trademarks

Epson is registered trademark of Epson Corporation.

Windows is registered trademark of Microsoft Corporation.

NANOPTIX is a trademark. Other trademarks and registered trademarks are the property of their respective holders.

Federal Communications Commission (FCC) Radio Frequency Interference Statement

Warning

Changes or modifications to this unit not expressly approved by the party responsible for compliance could void the user's authority to operate the equipment.

Note

This equipment has been tested and found to comply with the limits for a Class B digital device, pursuant to Part 15 of the FCC Rules. These limits are designed to provide reasonable protection against harmful interference when the equipment is operated in a commercial environment. This equipment generates, uses, and can radiate radio frequency energy and, if not installed and used in accordance with the instruction manual, may cause harmful interference to radio communications. Operation of this equipment in a residential area is likely to cause harmful interference in which case the user will be required to correct the interference at his own expense.



Information to the User

This equipment must be installed and used in strict accordance with the manufacturer's instructions. However, there is no guarantee that interference to radio communications will not occur in a particular commercial installation. If this equipment does cause interference, which can be determined by turning the equipment off and on, the user is encouraged to contact NANOPTIX Inc. immediately.

Nanoptix Inc. is not responsible for any radio or television interference caused by unauthorized modification of this equipment or the substitution or attachment of connecting cables and equipment other than those specified by Nanoptix Inc. The correction of interferences caused by such unauthorized modification, substitution or attachment will be the responsibility of the user.

In order to ensure compliance with the Product Safety, FCC and CE marking requirements, you must use the power supply, power cord, and interface cable, which was shipped with this product or which meet the following parameters:

Power Supply

UL Listed power supply with standard 60Hz-50Hz, 100-240VAC input and 24VDC output equipped with AC line filtering, over-current and short-circuit protection.

Use of this product with a power supply other than the Nanoptix Inc. power supply will require you to test the power supply and Nanoptix Inc. printer for FCC and CE mark certification.

Communication Interface Cable

An approved Nanoptix interface cable must be used with this product. Use of a cable other than Nanoptix approved product will require that you test the cable with the Nanoptix Inc. printer and your system for FCC and CE mark certification.

Power Cord

A UL listed, detachable power cord must be used. A power cord with Type SVT marking must be used. For applications outside the North America, power cords that meet the particular country's certification and application requirements should be used.

Use of a power cord other than described here may result in a violation of safety certifications that is in force in the country of use.

Industry Canada (IC)

Radio Frequency Interference Statement

This Class B digital apparatus meets all requirements of the Canadian Interference-Causing Equipment Regulations.

Cet appareil numérique de la classe B respecte toutes les exigences du Règlement sur le matériel brouilleur du Canada.

Table of Contents

Table of Contents	4
1 About the printer	8
Description of printer.....	8
General.....	9
Printer Interface Ports	11
Spill Proof	11
Spill Proof Cuts.....	13
2. Printer controls	14
Paper Loading	14
Spill Proof	14
Spill Proof Cuts.....	17
Resetting Printer	19
Spill Proof	19
Spill Proof Cuts.....	19
Paper Feed Button	20
Spill Proof	20
Spill Proof Cuts.....	20
Status LED	21
Spill Proof	21
Spill Proof Cuts.....	22
Testing the Printer	23
3 Troubleshooting the Printer	24
Pin designation of Communication Interfaces.....	24
RS-232 (DB-9) receptacle	24
RS-232 (DB-9) plug	24
RS-232 / RS-485 (DB-15) Receptacle	25
Cash Drawer (RJ-25) Modular Jack (Non-Telecom).....	25
RS-232 (DB-25) receptacle	26
Sensors an Switches	27
Printing Problems	28
Printer Does Not Work.....	28
Connector Layout, Main Controller PCB	29
PCB – Spill Proof.....	29
4 Media and Supplies Guide	30
Thermal Paper Specifications.....	30



Spill Proof Printer..... 30
Spill Proof Cuts Printer 30

Ordering Thermal Paper 31

Ordering Miscellaneous Supplies 32
Ordering Power Supply and Power Cord 32
Ordering Communication Cables 32

5 Mechanical Drawings..... 33

6 Spare parts replacement instructions..... 35

Spill Proof 35

Instruction SP-A: Removal of the top shell 35

Instruction SP-B: Removal of the main PCB 36

Instruction SP-C: Removal of printing mechanism 36

Spill Proof Cuts 38

Instruction SPC-A: Removal of the top shell..... 38

Instruction SPC-B: Removal of Daughter PCB 39

Instruction SPC-C: Removal of the main PCB 39

7 Printer Cleaning Instructions 40

8 Service & Support..... 43

Returning printers back to NANOPTIX for repairs (RMA) 43

Technical Support Contact Information..... 43

Figures

FIGURE 1: SPILL PROOF & SPILL PROOF CUTS	8
FIGURE 2: INTERFACE PORTS - SP	12
FIGURE 3: INTERFACE PORTS - SPC	13
FIGURE 4: OPEN DOOR - SP	14
FIGURE 5: INSERT NEW ROLL - SP	15
FIGURE 6: CLOSE DOOR - SP	15
FIGURE 7: TEAR OFF EXCESS - SP	16
FIGURE 8: OPEN DOOR - SPC.....	17
FIGURE 9: INSERT ROLL - SPC	17
FIGURE 10: CLOSE DOOR AND COVER - SPC.....	18
FIGURE 11: RESETTING- SP	19
FIGURE 12: RESETTING - SPC.....	20
FIGURE 13: PAPER FEED - SP	20
FIGURE 14: PAPER FEED - SPC	20
FIGURE 15: LED POSITION - SP.....	21
FIGURE 16: LED POSITION - SPC	22
FIGURE 17: STATUS TICKET.....	23
FIGURE 18: SENSORS & SWITCHES	27
FIGURE 19: CONNECTOR LAYOUT – SP.....	29
FIGURE 21: THERMAL PAPER PART NUMBERS	31
FIGURE 22: ORDERING THERMAL PAPER	31
FIGURE 23: DIMENSIONS (IN MM) - SP.....	33
FIGURE 24: DIMENSIONS (IN MM) – SPC	34
FIGURE 25 TOP SHELL - SP	35
FIGURE 26: JACK SCREWS.....	36
FIGURE 27: PRINTING MECHANISM 1 - SP.....	36
FIGURE 28: PRINTING MECHANISM 2 - SP	37
FIGURE 29: TOP COVER – SPC.....	38
FIGURE 30: PCB MOUNTING PLATE - SPC	39
FIGURE 31: MAIN PCB – SPC.....	39
FIGURE 32: REMOVE DUST	40
FIGURE 33: CLEAN PRINT HEAD	41
FIGURE 34: CLEAN ROLLER.....	41
FIGURE 35: CLEAN BRUSHES – SPC.....	42
FIGURE 36: CLEAN SENSOR.....	42



Tables

TABLE 1: SPILL PROOF SPECIFICATION	10
TABLE 2: SPILL PROOF CUTS SPECIFICATIONS	11
TABLE 3: INTERFACE PORTS - SP.....	11
TABLE 4: INTERFACE PORTS - SPC.....	13
TABLE 5: LED INFORMATION - SP	21
TABLE 6: LED INFORMATION - SPC.....	22
TABLE 7: RS232 RECEPTACLE INTERFACE (FEMALE).....	24
TABLE 8: RS232 PLUG INTERFACE (MALE)	24
TABLE 9: RS485/RS232 COMBO DB15 RECEPTACLE (FEMALE).....	25
TABLE 10: CASH DRAWER MODULAR JACK.....	25
TABLE 11: RS-232 DB25 RECEPTACLE (FEMALE)	26
TABLE 12: SENSORS / SWITCHES	27
TABLE 13: TROUBLESHOOTING PRINTING PROBLEMS.....	28
TABLE 14: PCB CONNECTORS - SP.....	29
TABLE 16: PAPER SPECS - SP.....	30
TABLE 17: PAPER SPECS - SPC	30
TABLE 18: POWER SUPPLIES AND CORDS	32
TABLE 19: COMMUNICATION CABLES PART NUMBERS	32
TABLE 20: TOOLS REQUIRED – SP	35
TABLE 21: TOOLS REQUIRED – SPC	38

1 About the printer

Description of printer

The Nanoptix Spill Proof and Spill Proof Cuts printers are extremely fast, quiet, and very reliable. With thermal printing technology, there is no ribbon cassette to change, and paper loading is extremely simple. The printers are small enough to fit almost anywhere and are easy to use with the ticket exiting from the top.

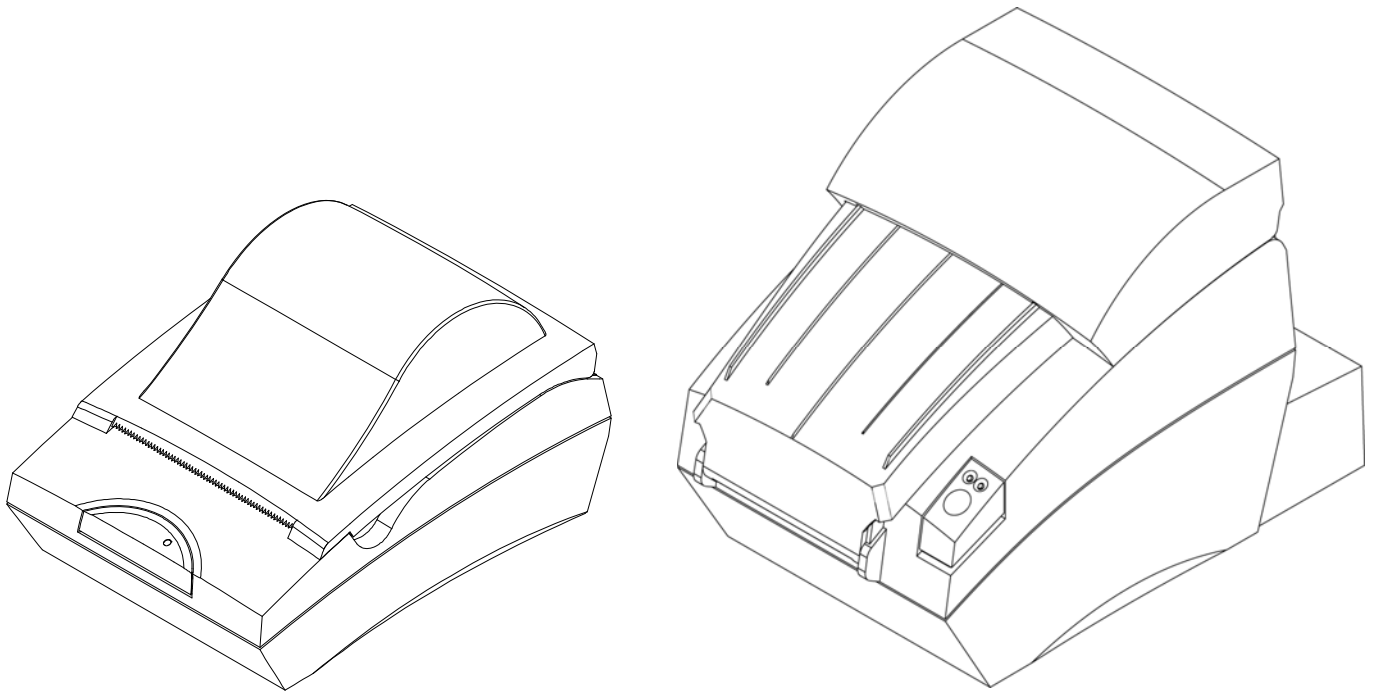

Figure 1: Spill Proof & Spill Proof Cuts



General

Print Method	Direct Thermal
Resolution	8 dot/mm (203 dpi)
Print Width	80mm
Paper Width	80mm or 82.5 mm
Max Roll Diameter	82.5mm
Operating Temperature	0 to 50 C
Storage Temperature	-40 C to +65 C
Operating Relative Humidity	5% to 90% RH at 50C (non-condensing)
Communication Interface Options	-USB, RS-232C, optional RS-485
Optional Interface	Cash Drawer Kick Out
Memory/Firmware	-8Mbit of RAM, 16Mbit of flash
Resident Character Sets	Arial Bold (6 sizes) Note: Other Character sets can be programmed quickly
Integrated Bar Codes	UPC-A, UPC-E, interleaved 2 of 5, 39, Code 128, EAN 8, EAN 13.
Speed	-Up to 125 mm/second
Sensors	Paper out Door open Top of form (optional)
Human Interface	Drop-in paper loading, status LED, paper feed button
Dimensions	130mm width x 110mm height x 180mm depth
Weight	0.55 Kg

<p>Agency Compliance</p>	<p>Underwriters Laboratory - UL 60950 Safety of Information Technology Equipment, including Electrical Business Equipment.</p> <p>Canadian Standards Association - CSA 22.2 No. 60950 Safety of Information Technology Equipment, including Electrical Business Equipment.</p> <p>TUV / VDE / GS Mark Safety of Information Technology Equipment, including Electrical Business Equipment.</p> <p>Underwriters Laboratories - IEC 60950 / EN 60950 CB Test Report and Certificate.</p> <p>IPX3</p>
<p>Emission Standards</p>	<p>United States - FCC Part 15 Subpart B Canada - Industry Canada ICES-003 Europe – EN 55022 Class B emissions</p>

Table 1: Spill Proof Specification

Print Method	Direct Thermal
Resolution	8 dot/mm (203 dpi)
Print Width	80mm
Paper Width	80mm or 82.5 mm
Max Roll Diameter	82.5mm
Operating Temperature	0 to 50 C
Storage Temperature	-40 C to +65 C
Operating Relative Humidity	5% to 90% RH at 50C (non-condensing)
Communication Interface Options	-USB, RS-232C, RS-485, IEEE1284
Optional Interface	Cash Drawer Kick Out
Memory/Firmware	-1 Mbit of SRAM, 4 Mbit of flash and 128Kbit of EEPROM
Resident Character Sets	Arial Bold (6 sizes) Note: Other Character sets can be programmed quickly
Integrated Bar Codes	UPC-A, UPC-E, interleaved 2 of 5, 39, Code 128, EAN 8, EAN 13. Note: Other Bar Codes can be programmed quickly
Speed	-Up to 250 mm/second
Sensors	Paper out Door open Top of form (optional)
Human Interface	Drop-in paper loading, status LED, paper feed

	button
Dimensions	145mm width x 179mm height x 198mm depth
Weight	1.56 Kg
Agency Compliance	Underwriters Laboratory - UL 60950 Safety of Information Technology Equipment, including Electrical Business Equipment Canadian Standards Association - CSA 22.2 No. 60950 Safety of Information Technology Equipment, including Electrical Business Equipment TUV / VDE / GS Mark Safety of Information Technology Equipment, including Electrical Business Equipment Underwriters Laboratories - IEC 60950 / EN 60950 CB Test Report and Certificate. Ipx1
Emission Standards	United States - FCC Part 15 Subpart B Canada - Industry Canada ICES-003 Europe – EN 55022 Class A emissions

Table 2: Spill Proof Cuts Specifications

Printer Interface Ports

Spill Proof

Port Identification	Connector Type	Function
A	DC Jack	24 VDC
B	USB type mini B	USB Communication
C	RJ25	Cash drawer
D	DB9 plug	RS232 C Communication
Optional at position D	DB9 receptacle	RS232 C Communication
Optional at position D	DB15 receptacle	RS232 C Communication , RS485 Communication

Table 3: Interface Ports - SP



Figure 2: Interface ports - SP

Spill Proof Cuts

Port Identification	Connector Type	Function
A	IEC-603220	Line supply 100-240 VAC
B	RJ25	Cash drawer
C	DB25 receptacle	RS232-C Communication
D	USB type B	USB communication

Table 4: Interface ports - SPC



Figure 3: Interface ports - SPC

2. Printer controls

Paper Loading

Caution: To prevent data loss, do not operate the printer if it runs out of paper.

Spill Proof

1. Open printer door by holding on to both sides of cover and lifting upwards



Figure 4: Open door - SP

2. Insert new roll of paper (unwinding from the bottom)



Figure 5: Insert new roll - SP

3. Close cover (with both hands) onto paper. In some instances a short piece of paper may be fed.



Figure 6: Close door - SP

4. Tear off and discard excess paper



Figure 7: Tear off excess - SP

Spill Proof Cuts

1. Open protective cover, then open printer door by pressing the door open button and lifting on the door.



Figure 8: Open door - SPC

2. Insert new roll of paper (unwinding from the top)



Figure 9: Insert roll - SPC

3. Close door by pressing on the grey “push here” area then close the protective cover. The printer will feed and cut a small amount of paper which should be discarded.



Figure 10: Close door and cover - SPC

Resetting Printer

Spill Proof

In the event of a fault condition, simply disconnect and reconnect the printer's power connection to reset. Once the printer is re-connected, it will go through a startup routine and reset itself.



Figure 11: Resetting- SP

Spill Proof Cuts

In the event of a fault condition, simply turn the power switch off and on again. The printer will go through a startup routine and reset itself



Figure 12: Resetting - SPC

Paper Feed Button

Press form feed button to advance the paper.

Spill Proof

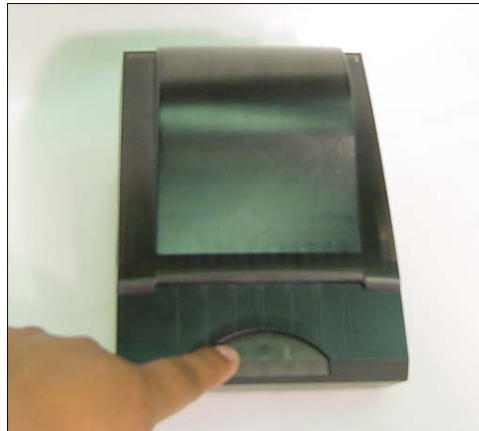

Figure 13: Paper Feed - SP

Spill Proof Cuts



Figure 14: Paper Feed - SPC

Status LED

Spill Proof

Condition	LED Status (Green)
Unit ready	ON
Unit is in Reset or Booting	OFF
Unit in standby (powered off)	OFF
Paper Out	Slow Blink
Door Open	Fast Blink
Paper Jam	Fast Blink
Missing Black Index Mark	Fast Blink
Temperature Error	Med Blink
Voltage Error	Med Blink
Print Head Error	Med Blink

Table 5: LED information - SP

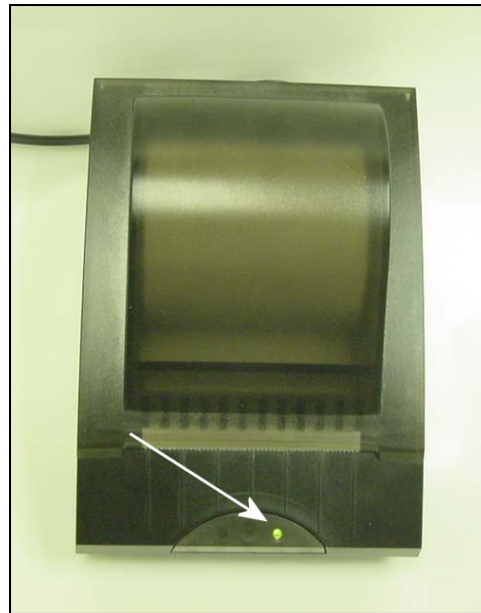

Figure 15: LED position - SP

Spill Proof Cuts

Condition	LED Status (Red)	Power LED (Green)
Unit ready	ON	ON
Unit is in Reset or Booting	ON	ON
Unit in standby (powered off)	OFF	OFF
Paper Out	Slow Blink	ON
Door Open	Fast Blink	ON
Paper Jam	Fast Blink	ON
Missing Black Index Mark	Fast Blink	ON
Temperature Error	Med Blink	ON
Voltage Error	Med Blink	ON
Print Head Error	Med Blink	ON

Table 6: LED information - SPC



Figure 16: LED Position - SPC

Testing the Printer

This test can be used to verify the correct operation of the printer. The test prints a resident ticket listing the current printer settings. This ticket can also be used to verify the printing quality. (Available in the Spill Proof as well as the Spill Proof Cuts).

```

Model:                               SPILL PROOF CUTS
Firmware:                             SPC-2.89Z
Protocol:                              EPSON 570
COMMUNICATION
Interface:                             Serial
Baud:                                  9600
Data Bits:                             8
Parity:                                NONE
Handshaking:                           PRT+RTS
Print Mode:                             Line
Aux Port:                               Disabled
PRINT CONTROL
Print Method:                           No HPQ
Speed:                                  150 mm/sec
Black Bar Index:                        Disabled
No HPQ Burn time                         240 us
Cutter PWM:                             80 %
Motor Current:                           3
Real-Time Comment                         Enabled
Validation Bit:                           After Barcode
PRINTER ENVIRONMENT CONDITIONS
Voltage:                                 24.2 Volts
Temperature:                             23 Celcius
SYSTEM RESOURCES
FLASH: Used=00000                       RAM: Used=00000
      Free=65535                          Free=65535
      LIBRARY INVENTORY                    (STANDARD)
Templates:                               0,1,2,3,4,5,6,7,8,9,A,B,F,
Regions:                                  1,2,3,4,5,6,7,8,h,9,A,B,C,
                                           D,E,F,G,I,J,K,L,N,O,P,Q,R,
                                           S,T,U,Z,X,a,b,c,d,e,f,g,i,
                                           j,k,l,m,n,o,p,q,r,s,t,u,v,w
Fonts:                                    0,1,2,3,4,5,7,8,9,A,B,E,P
Graphics:                                 None
MANUFACTURING INFORMATION
Printer ID:                              SPC0207
Date Code:                               20080505
A to D:                                  03d4,01fe,0208,03c6

*S 0 SPC-2.89Z @ @ @ H @ P *

```

Figure 17: Status ticket

To print the test ticket, power-on the printer while pressing and holding the Paper Feed Button for approximately 5 seconds. A test ticket similar to the one shown above will be printed. Pressing the button again will result in blank tickets.

3 Troubleshooting the Printer

Pin designation of Communication Interfaces

RS-232 (DB-9) receptacle

Pin	Signal Name	Printer I/O	Host I/O	Printer Function
1	AUX_PWR	5V Output	n/a	Aux Power (100mA)
2	RS232_TXD	Output	Input	Data transmit
3	RS232_RXD	Input	Output	Data receive
4	RS232_CTS	Input	Output	Handshaking
5	DGND	Ground	Ground	Signal Ground/Aux Ground
6	RS232_RTS	Output	Input	Handshaking
7	RS232_CTS	Input	Output	Handshaking
8	RS232_RTS	Output	Input	Handshaking
9	NC or PWR	No connect	No connect	Reserved

Table 7: RS232 receptacle Interface (female)

RS-232 (DB-9) plug

Pin	Signal Name	Printer I/O	Host I/O	Printer Function
1	AUX_PWR	5V Output	n/a	Aux Power (100mA)
2	RS232_RXD	Input	Output	Data receive
3	RS232_TXD	Output	Input	Data transmit
4	RS232_RTS	Output	Input	Handshaking
5	DGND	Ground	Ground	Signal Ground/Aux Ground
6	RS232_CTS	Input	Output	Handshaking
7	RS232_RTS	Output	Input	Handshaking
8	RS232_CTS	Input	Output	Handshaking
9	NC or PWR	No connect	No connect	Reserved

Table 8: RS232 plug Interface (male)

RS-232 / RS-485 (DB-15) Receptacle

Pin	Signal Name	Printer I/O	Host I/O	Printer Function
1	AUX_PWR	5V Output	n/a	Aux Power (100mA)
2	RS232_TXD	Output	Input	Data transmit
3	RS232_RXD	Input	Output	Data receive
4	No connect or CTS	Input	Output	None
5	DGND	Ground	Ground	Signal Ground/Aux Ground
6	Pull up or RTS	Output	Input	Handshaking
7	RS232_CTS	Input	Output	Handshaking
8	RS232_RTS	Output	Input	Handshaking
9	Pull up	Output	Input	None
10	No connect	Reserved	Reserved	Reserved
11	RS485_-TXD	Output	Input	Handshaking
12	RS485_+TXD	Output	Input	Handshaking
13	RS485_-RXD	Input	Output	Handshaking
14	RS485_+RXD	Input	Output	Handshaking
15	DGND	Ground	Ground	Signal Ground/Aux Ground

Table 9: RS485/RS232 combo DB15 receptacle (female)

Cash Drawer (RJ-25) Modular Jack (Non-Telecom)

Pin	Signal Name	Printer I/O	Device I/O	Printer Function
1	DGND	Ground	Ground	Power Ground
2	Cash 1	Ground pulse	Sol- (A)	Solenoid (A) ground sink
3	V24	Supply	Sw & Sol+(A)	Solenoid/Switch Supply
4	V24	Supply	Sw & Sol+(A)	Solenoid/Switch Supply
5	Cash 2	Ground pulse	Sol- (B)	Solenoid (B) ground sink
6	Stat	Input	Switch	Drawer status

Table 10: Cash Drawer Modular Jack

RS-232 (DB-25) receptacle

Pin	Signal Name	Printer I/O	Host I/O	Printer Function
1	DGND	Ground	Ground	Signal Ground/Aux Ground
2	RS232_TXD	Output	Input	Data transmit
3	RS232_RXD	Input	Output	Data receive
4	RS232_RTS	Output	Input	Handshaking
5	RS232_CTS	Input	Output	Handshaking
6	nc or RS232_CTS	Input	Output	Handshaking
7	DGND	Ground	Ground	Signal Ground/Aux Ground
8	nc or 4K7 pull up	5V Output	n/a	Aux Power (100mA)
9	NC	No connect	No connect	Reserved
10	NC	No connect	No connect	Reserved
11	NC	No connect	No connect	Reserved
12	NC	No connect	No connect	Reserved
13	NC	No connect	No connect	Reserved
14	NC	No connect	No connect	Reserved
15	NC	No connect	No connect	Reserved
16	NC	No connect	No connect	Reserved
17	NC	No connect	No connect	Reserved
18	NC	No connect	No connect	Reserved
19	NC	No connect	No connect	Reserved
20	RS232_RTS or 4k7pu	Output	Input	Handshaking
21	NC	No connect	No connect	Reserved
22	NC	No connect	No connect	Reserved
23	NC	No connect	No connect	Reserved
24	NC	No connect	No connect	Reserved
25	INIT	Input	Output	System Reset (active high)

Table 11: RS-232 DB25 Receptacle (Female)

Sensors an Switches

Sensor / Switch	Function
A	Door Closed
B	Paper Out

Table 12: Sensors / Switches

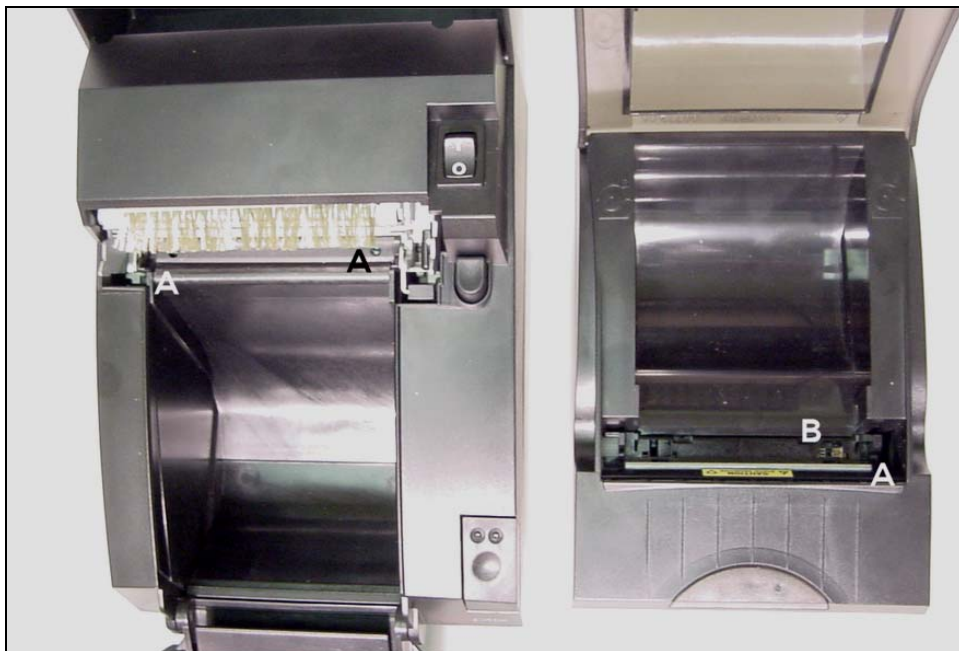

Figure 18: Sensors & Switches

Printing Problems

The table below can be used to determine the cause and resolution of the most common problems that may occur. If the information in this section does not correct the problem, contact your authorized service representative.

Problem	Possible Causes	What to Do
Receipt does not come out all the way.	Paper is jammed.	Open the top cover, inspect and clear any jammed paper.
Printer starts to print, but stops while the receipt is being printed.	Paper is jammed.	Open the receipt cover, inspect and clear any jammed paper.
Print is light or spotty.	Paper roll loaded incorrectly.	Check that the paper is loaded properly.
	Thermal print head is dirty.	Use recommended thermal receipt paper. Clean the Print Head with Nanoptix authorized cleaner.
Vertical column of print is missing.	This indicates a serious problem with the printer electronics.	Contact your authorized service representative.
One side of receipt is missing.	This indicates a serious problem with the printer electronics.	Contact your authorized service representative.

Table 13: Troubleshooting printing problems

Printer Does Not Work

Problem	Possible Causes	What to Do
Printer Does Not Function When Turned On.	Printer not plugged in.	Check that printer cables are properly connected on both ends.
		Check that the host or power supply is switched on. Check Printer LED.
	Door not fully closed.	Close the door.

Table 4: Printer does not work

Connector Layout, Main Controller PCB

PCB – Spill Proof

Letter	Cable designation	Connector Color	Main PCB designation	Function
A	None	beige	J500	paper feed, LED
B	None	beige	J400	feeder motor
C	None	black	J300	print head I/O
D	None	black	J600	cover open, paper in
E	None	metal	None	TPH GND

Table 14: PCB connectors - SP

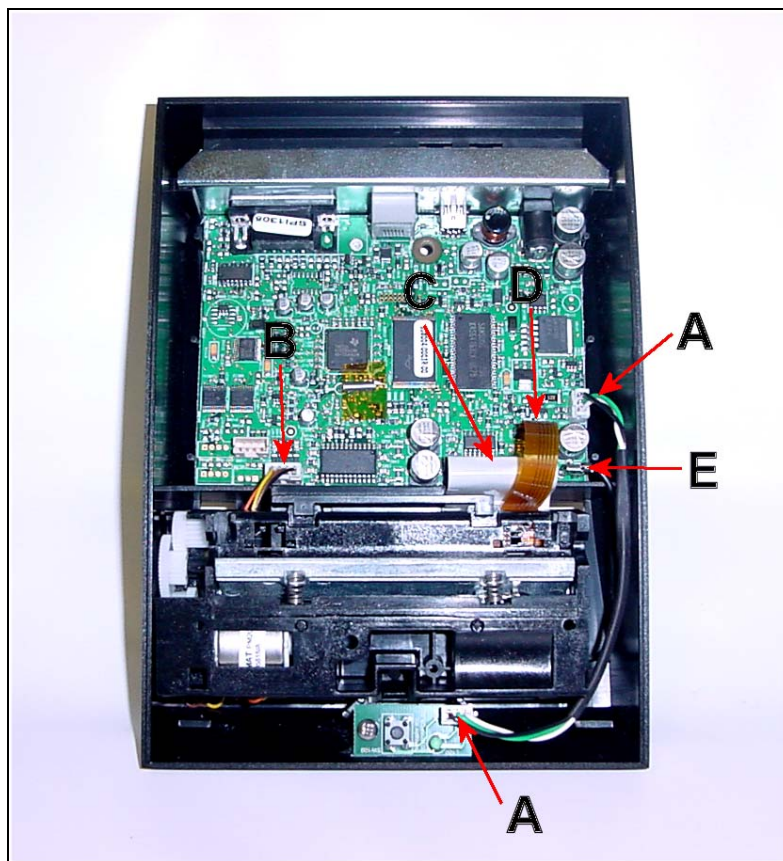

Figure 19: Connector layout – SP

4 Media and Supplies Guide

Thermal Paper Specifications

The printer requires qualified thermal paper with the following dimensions:

Spill Proof Printer

Width	Diameter	Outside Core Diameter
80 mm ± .2 mm (3.15 in. ± .008 in.)	115 mm max. (4.5 in.)	45mm (1.75 inches)
82.5 mm ± .2 mm (3.25 in. ± .008 in.)	115 mm max. (4.5 in.)	45mm (1.75 inches)

Table 15: Paper specs - SP

Spill Proof Cuts Printer

Width	Diameter	Outside Core Diameter
80 mm ± .2 mm (3.15 in. ± .008 in.)	125 mm max. (5 in.)	45mm (1.75 inches)
82.5 mm ± .2 mm (3.25 in. ± .008 in.)	125 mm max. (5 in.)	45mm (1.75 inches)

Table 16: Paper specs - SPC

Note: The paper should not be attached to the core.

Ordering Thermal Paper

The following are the recommended paper grades produced by their respective manufacturers. There is a number of paper converters qualified to supply this paper, provided the thermal paper rolls are from these recommended grades.

NANOPTIX p/n	Paper Grade	Manufacturer	Paper Width	Thickness
100505-2010	P350	Kanzaki	80mm	61um (2.4mil)
100505-2016	P350	Kanzaki	82.5mm	61um (2.4mil)

Figure 20: Thermal Paper part numbers

Manufacturer	Numbers
Kanzaki Specialty Papers (USA) 1350 Main Street Springfield, MA 01103	1.888.KANZAKI Tel: 888-526-9254 Fax: 413-731-8864

Figure 21: Ordering Thermal Paper

Additional grades can be qualified and made available. Please contact Nanoptix for more information.

Ordering Miscellaneous Supplies

Ordering Power Supply and Power Cord

NANOPTIX p/n	Part Description
102080-0000R	Power Cord –North America (standard C13 “)
102080-0001R	Power Cord -Continental Europe (standard C13)
102080-0003R	Power Cord-ARGENTINA
270005-0001R	24V, 60W Power Supply GS-1110
270005-0002R	24V, 60W Power Supply GS-1110 ARGENTINA

Table 17: Power Supplies and cords

Ordering Communication Cables

Part Number	Part Description
102085-0002R	USB communication cable (Type mini B to A)
102082-0000R	Serial cable (DB-9 male to DB-9 female)
102928-0000R	Serial cable (DB9 male to DB9 male)
102805-0000R	Serial Null Modem cable (DB9 female to DB9 female)
102927-0000R	Serial Null Modem cable (DB9 female to DB9 male)
102911-0000R	Adaptor harness (DB9 Female to RJ45)
102911-0001R	Over moulded cable (IGT specific) “Axiohm”
102270-0000R	Cash Drawer harness (RJ11-RJ11)

Table 18: Communication Cables Part Numbers

Please note: The *NANOPTIX part number* must be specified when ordering communication cables.

5 Mechanical Drawings

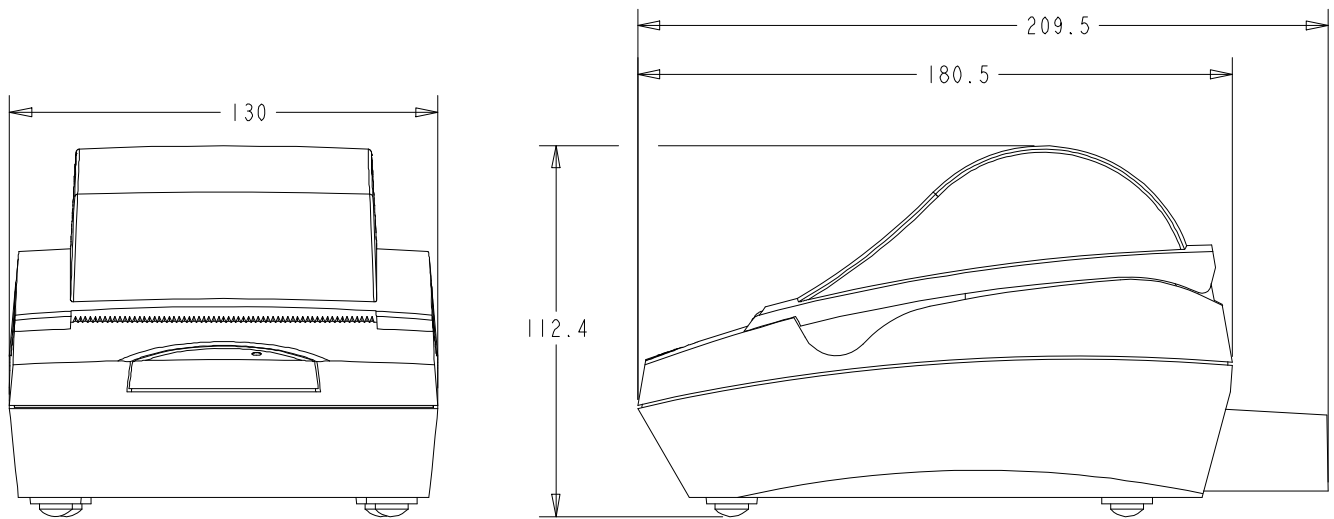

Figure 22: Dimensions (in mm) - SP

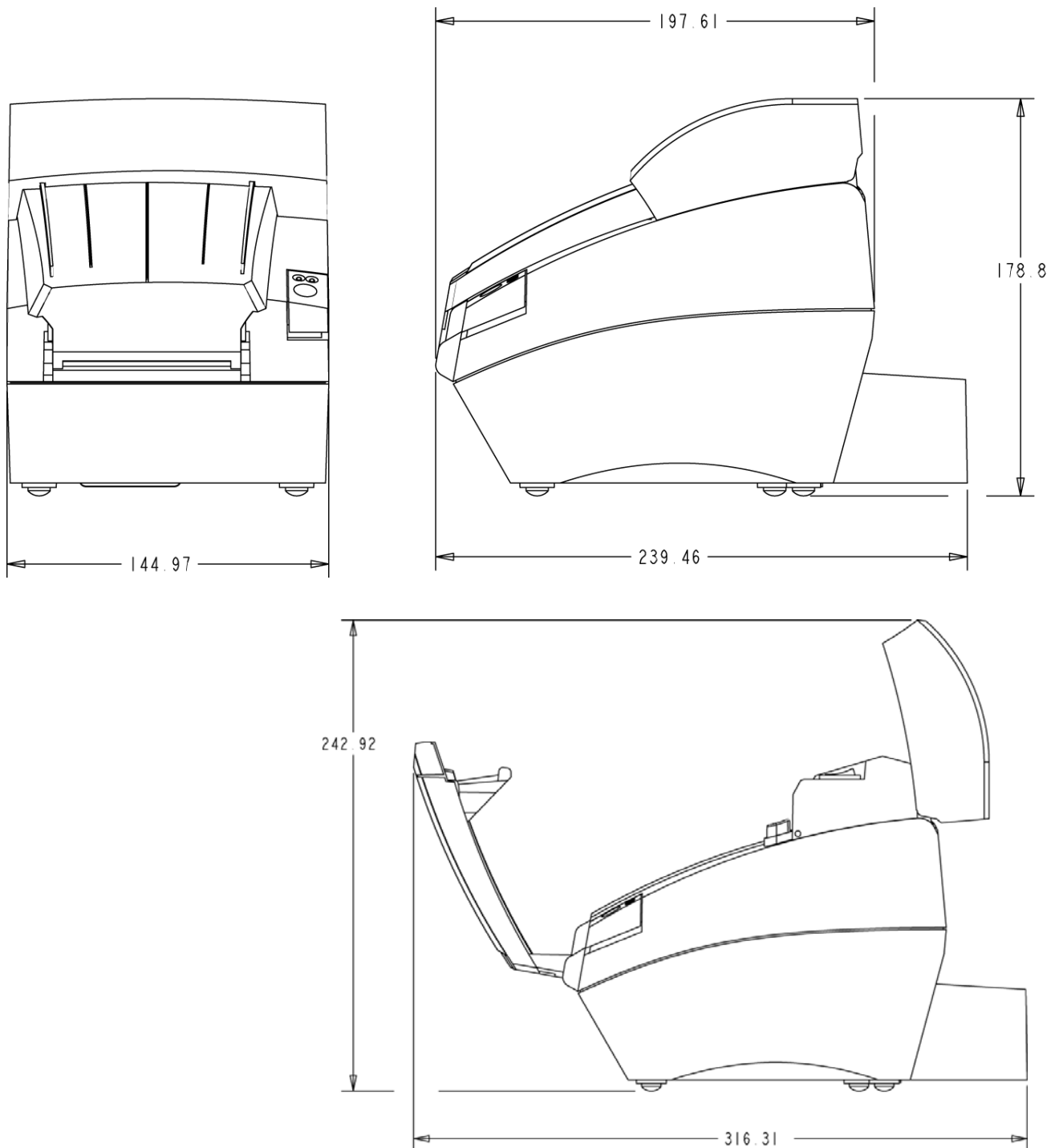

Figure 23: Dimensions (in mm) – SPC

6 Spare parts replacement instructions

Note: Follow instructions below for disassembly of defective parts. Follow instructions in the reverse order for reassembly.



Use ESD protection (such as a wrist strap) anytime a PCB is exposed



Spill Proof

Tools required:

REFERENCE	DESCRIPTION
TOOL 1	SOCKET HEAD SCREWDRIVER. # 3/16 (5.5mm)
TOOL 2	SCREWDRIVER, PHILIPS #1

Table 19: Tools Required – SP

Instruction SP-A: Removal of the top shell

1. Remove screw as shown in Figure 24 using tool 2
2. Then turn printer back on its feet, open cover and pull up on top shell to remove

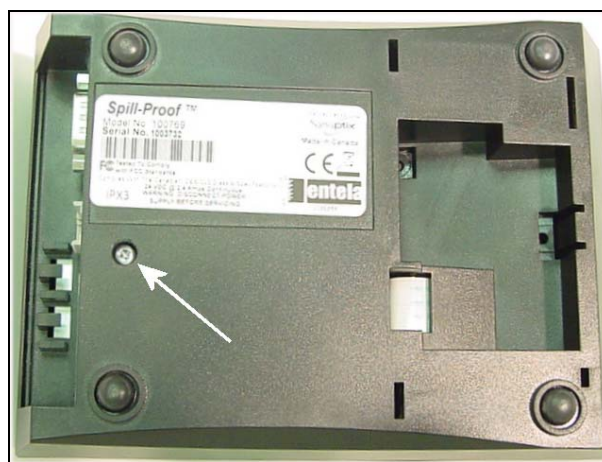

Figure 24 Top shell - SP

Instruction SP-B: Removal of the main PCB

1. Remove top shell by following instruction A
2. Disconnect all power and communication connections
3. Remove two (2) screws as shown in Figure 25 using tool 1
4. Refer to Table 14 and Figure 19 to remove all connections, then remove Main PCB



Figure 25: Jack Screws

Instruction SP-C: Removal of printing mechanism

1. Remove top shell by following instruction A
2. Refer to Table 14 and Figure 19 to remove all 3 printing mechanism connections



Figure 26: Printing mechanism 1 - SP

3. Lift up on front part of mechanism then slide forward to release from the two (2) lances as shown in Figure 28

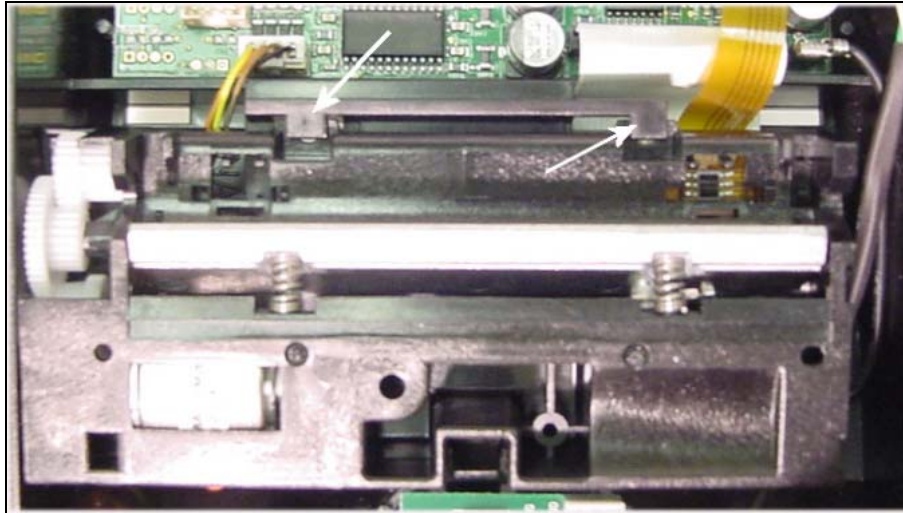

Figure 27: Printing Mechanism 2 - SP

Spill Proof Cuts

Tools required:

REFERENCE	DESCRIPTION
TOOL 1	SOCKET HEAD SCREWDRIVER. # 3/16 (5.5mm)
TOOL 2	SCREWDRIVER, PHILIPS #1,#2
TOOL 3	SCREWDRIVER, FLAT #1/4 (6mm)

Table 20: Tools Required – SPC

Instruction SPC-A: Removal of the top shell

1. Remove 4 screws as shown in Figure 28 using tool 2
2. Then turn printer back on its feet and open printer cover and door. Pull up to remove.



Figure 28: Top Cover – SPC

Instruction SPC-B: Removal of Daughter PCB

1. Remove four (4) screws as shown Figure 29 using tool 1&2.
2. Then slide board out to remove



Figure 29: PCB mounting plate - SPC

Instruction SPC-C: Removal of the main PCB

1. Remove top shell by following Instruction A
2. Remove daughter PCB by following instruction B
3. Refer to **Error! Reference source not found.** and Figure 20 to remove all connections
4. Remove two (2) screws using tool 2, list up to remove

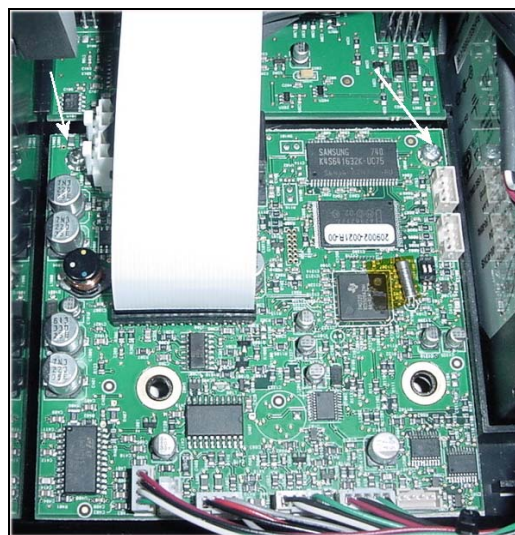

Figure 30: Main PCB – SPC

7 Printer Cleaning Instructions

Note: Under normal operating conditions, the minimum interval for cleaning the NANOPTIX SPILL PROOF & SPILL PROOF CUTS printer is *3 months* or *5 km* of paper printed, whichever comes first. Isopropyl alcohol cleaning pens and pre-saturated cleaning cards are available from Nanoptix.

Step 1: Open printer door and wipe off or vacuum the accumulated dust



Spill Proof



Spill Proof Cuts

Figure 31: Remove dust

Step: 2 Clean the print line (black line on the print head) with a cotton swab and isopropyl alcohol.



Spill proof



Spill proof cuts

Figure 32: Clean print head

Step 3: Clean roller with a cotton swab and isopropyl alcohol



Spill proof



Spill proof cuts

Figure 33: Clean roller

Step 4: Clear dust off static brushes using a vacuum or light brush (Spill Proof Cuts only)



Figure 34: Clean brushes – SPC

Step 5: Clean paper sensor with a cotton swab and isopropyl alcohol



Spill proof



Spill proof cuts

Figure 35: Clean sensor



8 Service & Support

Returning printers back to NANOPTIX for repairs (RMA)

- Send return approval request to NANOPTIX Inc. which should include:
 - Printer model #
 - Serial #
 - Brief problem description
- Ship defective products to NANOPTIX Inc.
- Ensure that each package being sent is identified by the specified RMA number

NOTE: Make sure to insert a blank ticket or a piece of paper between thermal print head and roller for shipping and storage.

Canada and International

RMA # XXXXXX
NANOPTIX Inc.
699 Champlain St.
Dieppe, NB, Canada
E1A 1P6

United States of America

RMA # XXXXXX
NANOPTIX Inc.
C/o Brunswick Brokers
48 Customs Loop
Houlton, ME, USA
04730

Australia

RMA # XXXXXX
NANOPTIX Inc.
c/o Consolidated Poker Machines
6/4A Foundry Road
Seven Hills, NSW, Australia
2147

Europe

RMA # XXXXXX
NANOPTIX Inc.
c/o Axiohm SAS
33 bis, route de Malesherbes
PUISEAUX, France
45390

NOTE: It is imperative that every package clearly identified by an RMA number.

Technical Support Contact Information

Service Dept.
NANOPTIX Inc.
699 Champlain St.
Dieppe, NB, Canada
E1A 1P6
Tel: 506.384.3388 x213
Fax: 506.384.3588
E-mail: support@nanoptix.com
Web site: www.nanoptix.com