



Light Duty Parts & Service Manual

Ford 1999-2005 F250/350 & F450/550 Models

Unit Serial Number: _____

Record the MODEL and SERIAL NUMBER of equipment for parts ordering information.

PURCHASED FROM: _____

DATE: _____

MODEL: _____

SERIAL NUMBER: _____



TABLE OF CONTENTS

<u>DESCRIPTION</u>	<u>PAGE NO</u>
WARRANTY POLICY	3
WARRANTY REQUEST PROCEDURE	4
INTRODUCTION	5
PERIODIC MAINTENANCE INSPECTION	5
DAILY INSPECTION AND LUBRICATION	5
REGISTRATION OF EQUIPMENT AND WARRANTY INFORMATION	6
MOUNTING KIT ASSEMBLY PART NUMBER	7
MOUNTING KIT ASSEMBLY FOR 1999-2004 F250/350s	8-9
MOUNTING KIT ASSEMBLY FOR 1999-2004 F450/550s	10-11
INSTALLATION INSTRUCTIONS FOR FORD SUPER DUTY	12-14
INSTALLATION INSTRUCTIONS FOR 2005 FORD	15
ATTACH KIT FOR 2005 FORD	16
MOLDBOARD/PUSHFRAME ASSEMBLY INSTRUCTIONS	17
CUSHION VALVES W/CENTRAL HYDRAULIC SYSTEM	18
MAINTENANCE PROCEDURE	19
TORQUE ARM REMOVAL	20
SNO-KING MODEL FOR 8', 9', & 10' LD PLOWS	21
LIFT FRAME/HITCH PARTS FOR 8', 9', & 10' MODELS	22-23
834DT LD 8' PLOW/MOLDBOARD PARTS	24
934DT LD 9' PLOW/MOLDBOARD PARTS	25
1034DT LD 10' PLOW/MOLDBOARD PARTS	26
STEEL MOLDBOARD DRAWING	27
POLY MODBOARD DRAWING	28
REMOVING CUTTING EDGE	29
OPTIONAL RUBBER DEFLECTOR	30
MODEL DT 8', 9', & 10' PUSHFRAME/"A" FRAME PARTS	31-32
INSTA-MOUNT REMOVAL INSRUCTIONS	33
INSTA-MOUNT INSTALLATION INSTRUCTIONS	34
GENERAL OPERATING INSTRUCTIONS	35
LIGHT KIT PARTS	36
ELECTRIC POWER UNIT	37-41
WARRANTY	42



WARRANTY POLICY

VIKING-CIVES MIDWEST warrants products of its manufacture against defects in workmanship and material for a period of one year, from the date of shipment to the customer. In consequence of this warranty, any component part or parts of such products proving defective within the above specified time will be repaired or replaced F.O.B. factory. Providing such parts are returned, transportation prepaid, to the factory and found defective by VIKING-CIVES MIDWEST.

This warranty will not apply to any product which has been repaired or altered outside of VIKING-CIVES MIDWEST factory in any way, so as in VIKING-CIVES MIDWEST's judgement, to affect its stability or reliability, nor which has been subject to misuse or accident.

The obligations of VIKING-CIVES MIDWEST under this warranty are limited to the replacement of defective parts. Such obligations are exclusive and in lieu of all other remedies, warranties, guarantees of liabilities, expressed or implied, with respect to each product delivered, hereunder, arising by law or otherwise (including without limitation any obligation or liability by VIKING-CIVES MIDWEST arising from negligence or with respect to fitness, merchantability, loss of use, revenue, or profit, or consequential damages or injuries).

This limited warranty shall not be extended, altered, or varied except by a written instrument signed by VIKING-CIVES MIDWEST.

VIKING-CIVES MIDWEST assumes no responsibility for engines, electrical equipment or any other equipment and accessories not manufactured by VIKING-CIVES MIDWEST beyond the warranty of the manufacturer of such equipment of accessories.

All warranty work done on VIKING-CIVES MIDWEST equipment must have prior authorization from VIKING-CIVES MIDWEST along with a **"Return Goods Authorization"** number. All labor and parts issued by user for VIKING-CIVES MIDWEST warranty without an authorization number and a signed authorization warranty form will be at the users own cost.

ORDERING PARTS

Delays and errors can be eliminated when ordering instructions are followed correctly.

1. Place orders direct with Viking-Cives Group/nearest dealer.
2. State Company name, address, and postal/zip code.
3. Give the exact model and serial number of the equipment/unit (stamped on the unit identification plate.)
4. Furnish part number, description and quantities required. *Note: An alpha designation in the Item ID column indicates a sub-component for that parent item. When placing parts orders reference the parent item to receive a complete assembly. Individual items can be ordered separately if required by ordering the alpha designated item number.*
5. Print or type order clearly.
6. Give specific shipping instructions.

VIKING-CIVES (USA) – RR2, Box 36-1/2; Harrisville, New York 13648; (315) 543-2321, (315) 543-2366 Fax

VIKING-CIVES (USA) Midwest Division – 212 North Evans Road; Evansdale, Iowa 50707; (319) 236-7977, (319) 236-7980 Fax

VIKING-CIVES LTD. – RR4, Box 1120; Mount Forest, Ontario, Canada N0G 2L0; (519) 323-4433, (519) 323-4608 Fax



WARRANTY REQUEST PROCEDURE

All repairs considered for warranty that are performed outside of VIKING – CIVES MIDWEST; require prior written authorization from VIKING – CIVES MIDWEST. Failure to obtain written warranty authorization prior to repairs may result in the rejection of the warranty claim. **To obtain warranty consideration one must provide all required VIKING – CIVES MIDWEST with unit information including date of manufacture and serial numbers.** In most cases this information is easily obtained from the “Shipped Unit Tag” (located in most cases inside the driver’s side door) and/or individual unit serial tag.

(A) To obtain Parts Warranty Consideration:

- (1) Contact VIKING – CIVES MIDWEST customer service to obtain a Return Goods Authorization (RGA) number. Any product arriving at VIKING – CIVES MIDWEST without a RGA number will be rejected and returned to the sender at his or her own expense.
- (2) Goods are to be shipped prepaid to VIKING – CIVES MIDWEST, Evansdale, Iowa 50707. **All items should be clearly marked with the appropriate RGA number.**
- (3) When a replacement item is shipped to replace a defective part for warranty consideration the following additional steps will occur:
 - a) An invoice will be generated for the value of the replacement item(s).
 - b) The defective part(s) must be returned (prepaid) to VIKING – CIVES MIDWEST.
 - c) Upon receiving the defective part(s) VIKING – CIVES MIDWEST will issue and process a Discrepant Material Report (DMR). Once the evaluation of the DMR report is complete and the parts are deemed warranty, a credit will be issued against the outstanding invoice. **If the part(s) are deemed Non-warranty the invoice will remain outstanding to be paid to VIKING – CIVES MIDWEST.** Any part(s) to be returned to the customer will be at his or her own expense.

(B) To obtain Labor Parts Repair Warranty Consideration:

In the event that repairs are required outside of VIKING – CIVES MIDWEST facility that may be considered for warranty the following steps must occur. **Notification of VIKING – CIVES MIDWEST customer service must take place prior to the start of any repairs.**

- (1) Contact VIKING – CIVES MIDWEST customer service to obtain a Warranty Claim Form (WCF) and warranty authorization number.
- (2) Fill out all required WCF information and fax or mail the completed form to VIKING – CIVES MIDWEST, attention Customer Service Department.
- (3) Once the WCF report has been reviewed warranty authorization will be granted or denied. **NOTE: VIKING – CIVES MIDWEST warranty labor rates will apply unless specifically determined otherwise.** Any part(s) involved in a WCF request must follow the Parts Warranty Consideration procedures.

For Customer Service and/or Parts requests please contact:

Craig La Rue – (clarue@vikingcives.com)
Ph. (319) 236-7977; Fax (319) 236-7980



INTRODUCTION

This instruction/parts manual has operation and maintenance information for the Viking-Cives Sno-King Equipment. It has been prepared to familiarize you with the design features of the unit, and to instruct you in its proper operation and maintenance.

Read this manual carefully before you operate and/or service your Sno-King Equipment. Remember that you're working with heavy equipment that can injure you or someone else. You can help lessen the chance of injury by following the procedures in this manual, carefully.

DANGER: If incorrectly used, this equipment can cause severe injury. Your chance of injury can be greatly reduced by following all caution/warning decal notifications. All decals must be kept clean and complete. Replace any decals that are unreadable. Decals may be purchased directly from Viking-Cives Group and/or the nearest authorized dealer. All Operator/Service people should review this manual carefully and become familiar with its contents. **If anyone else beside you operates or services this equipment, make sure they read this manual and are instructed to follow the safety procedures related to this equipment.**

PERIODIC MAINTENANCE INSPECTION DAILY INSPECTION AND LUBRICATION

Daily inspection along with periodic preventive maintenance will reduce the chance of any major repairs and down time during equipment use.

1. Check the fluid level in the hydraulic oil reservoir. If the sight indicates low oil level, add the appropriate amount of the specified hydraulic fluid. **Cold Weather Operation:** All equipment is designed to operate with hydraulic oil minimally warm. During cold weather conditions, it is recommended that the truck be run at idle with the pump engaged and circulating the oil through the system before operating equipment.
2. Grease all required components:
 - All plow harness sheave nipples.
 - All pump drive shaft nipples.
 - Front and Rear tower sheave swivel blocks.
 - Wing extension arm nipples.
 - Front and Rear tower guide tracks.
 - All front harness pivot points.
3. Check all components for loose and/or missing fasteners, if required tighten and/or replace.
4. Visually inspect all battery terminals and electrical connections, wires, switches, etc. for signs of corrosion, wear, loose and/or broken connections, etc. At the beginning of each shift review all lighting accessories to ensure proper working conditions, immediately replace any broken or non-functioning bulbs and/or lenses.
5. Visually inspect all hydraulic connections and hoses for cracks and/or leaks.
6. Check all cables, chains and sheaves for excessive wear or damage.
7. Visually inspect plow and wing units. Check cutting edges and wear shoes. If cutting edge has excessive wear remove and rotate, or if required replace. **CAUTION:** Do not allow cutting edge to wear down to mounting angle. Any wear to the mounting angle may affect the operation and safety of the equipment. Replacement is costly.
8. At the beginning of each shift visually inspect all caution and warning decals. All decals should be complete and legible. If decals are not legible, clean them. If cleaning the decals does not make them legible, install new decals.



REGISTRATION OF EQUIPMENT AND WARRANTY INFORMATION

Report any damage to equipment at once to VIKING-CIVES MIDWEST. You should also register your equipment with VIKING-CIVES MIDWEST, by filing out a warranty certificate and registration card and returning them to VIKING-CIVES MIDWEST. The warranty period becomes effective upon date of delivery of equipment unless other arrangements have been made with a VIKING-CIVES MIDWEST Distributor or VIKING-CIVES MIDWEST. The information required to register the equipment may be found on the serial number tag secured to the equipment.

VIKING-CIVES, LTD.
Mt. Forest, Ontario, Canada

Model

Serial No.

VIKING - CIVES, LTD.
Mt. Forest, Ontario, Canada

Date Completed

This Vehicle Conforms to All Applicable Motor
Vehicle Safety Standards in Effect on Date
of Manufacture

Unit Number

VIN

A WORD ABOUT SAFETY:

The equipment described in this manual is normally being operated in adverse winter conditions with bad weather, snow and ice. Due to these adverse operating conditions it is important that you the operator use good safety practices at all time to protect yourself, co-workers and others when using the equipment.

It is not practical or possible to warn you about all the hazards associated with the operation and maintenance of this equipment. You should always use your own good judgment supplemented with the information found on the safety decals, instructions in this manual, your employer's safety programs, safety codes, local, state/provincial, and federal laws, rules and regulations.

When operating/performing maintenance on this equipment, trouble shooting equipment operations and loading or unloading the sanders/spreaders with material observe & obey all safety decals on the equipment and warnings listed in the manual. Failure to do this could result in serious injury or death to you or others.

Remember at all times that as the operator you are responsible for the safe operation of this equipment and responsible for the safety of others. Good safety practices not only protect you but also protect the people around you.

**MOUNTING KIT ASSEMBLY PART NUMBER
ACCORDING TO TRUCK MAKE, MODEL, & YEAR**

REF NO.	PART NO.	DESCRIPTION	REQ.
see parts list on pg 8 & drawing on pg 9	3SK1510	1999 Ford F250/350 Mounting Kit with Hardware	1
	3SK1511	2000-2004 Ford F250/350 Mounting Kit with Hardware	1
see parts list on pg 10 & drawing on pg 11	3SK1520	1999 Ford F450/550 Mounting Kit with Hardware	1
	3SK1521	2000-2004 Ford F450/550 Mounting Kit with Hardware	1

**MOUNTING KIT ASSEMBLY, PART 3SK1510/3SK1511
1999-2004 FORD F250/350s**

Mounting Weldment Pieces:

SHOWN FOR REFERENCE ONLY-SOLD AS COMPLETE KIT

REF NO.	PART NO.	DESCRIPTION	REQ.
A	3SK1510/1511	Right/Left Hand Brackets "A"	2
B	3SK1510/1511	Right/Left Hand Receiver Mounting Brackets	2
C	3SK1510/1511	Right/Left Hand Tailpiece Brackets	2
D	3SK1510/1511	Right/Left Hand Side Plates	2
E	3SK1510/1511	Right/Left Hand "E" Brackets	2
F	3SK2210	Receiver Bracket (Not Part of Mounting Kit)	1
(not shown)	3SK3480	Spring Loaded Pin Assembly (Not Part of Mounting Kit)	1

Mounting Hardware:

REF NO.	PART NO.	DESCRIPTION	REQ.
3	3SK3620	½" X 2½" NC Capscrew (2 required per side)	4
4	3SK3610	½" X 2" NC Capscrew (2 required per side)	4
2	3SK3600	½" X 1½" NC Capscrew (7 required per side)	14
1	3SK3700	5/8" X 2" NC Capscrew (4 required per side)	8
6	3SK3670	½" Locknut (11 required per side)	22
5	3SK3681	5/8" Locknut (4 required per side)	8

F-250/350 MOUNTING KIT 1999-2004

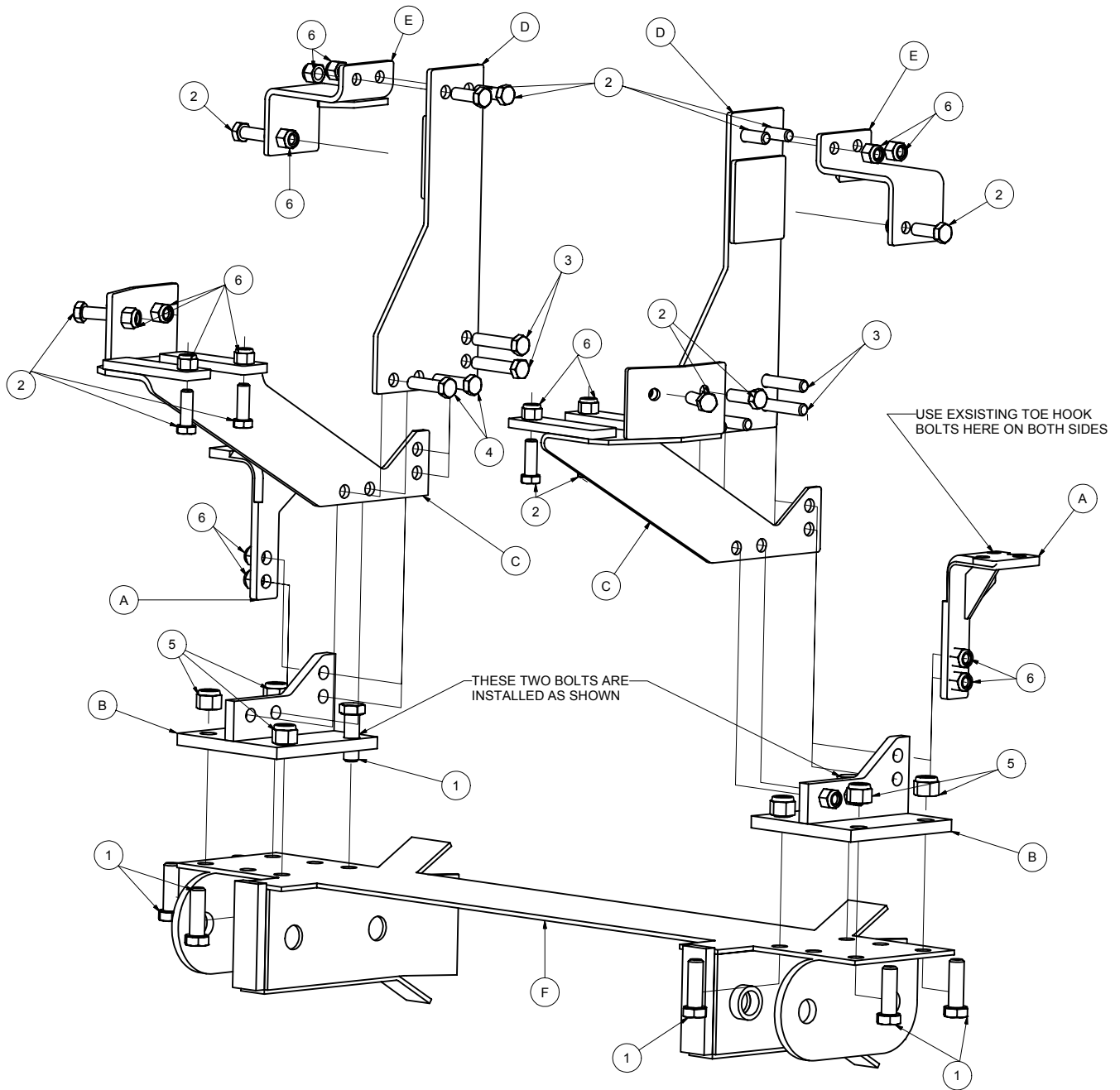

NOTES: IF YOU HAVE 2004
MODEL REQUEST BLOCKER
BEAM MODIFICATION SHEET

ITEM	DRAWING NO.	ALT. ITEM NO.	DESCRIPTION	QTY
A	SK1520/1521		RIGHT/LEFT HAND "A" BRACKET	2
B	SK1520/1521		RIGHT/LEFT HAND MOUNTING BRACKET	2
C	SK1520/1521		RIGHT/LEFT HAND TAILPIECE BRACKET	2
D	SK1520/1521		RIGHT/LEFT HAND SIDE PLATE	2
E	SK1520/1521		RIGHT/LEFT HAND "E" BRACKET	2
F	SK2210		RECIEVER BRACKET	1
1	3SK3700		BOLT HEX 5/8 X 2 UNC ZINC	8
2	3SK3600		BOLT HEX 1/2 X 1 1/2 UNC ZINC	14
3	3SK3620		BOLT HEX 1/2 X 2 1/2 UNC ZINC	4
4	3SK3610		BOLT HEX 1/2 X 2 UNC ZINC	4
5	3SK3781		NUT HEX TOPLOCK 5/8 UNC ZINC	8
6	3SK3670		NUT HEX TOPLOCK 1/2 UNC ZINC	22

**MOUNTING KIT ASSEMBLY, PART 3SK1520/3SK1521
1999-2004 FORD F450/550s**

Mounting Weldment Pieces:

SHOWN FOR REFERENCE ONLY-SOLD AS COMPLETE KIT

REF NO.	PART NO.	DESCRIPTION	REQ.
A	3SK1520/1521	Right/Left Hand Bracket "A"	2
B	3SK1520/1521	Right/Left Hand Receiver Mounting Brackets	2
C	3SK1520/1521	Right/Left Hand Tailpiece Brackets	2
D	3SK1520/1521	Right/Left Hand Side Plates	2
E	3SK1520/1521	Right/Left Hand "E" Brackets	2
F	3SK2210	Receiver Bracket (Not Part of Mounting Kit)	1
(not shown)	3SK3480	Spring Loaded Pin Assembly (Not Part of Mounting Kit)	1

Mounting Hardware:

REF NO.	PART NO.	DESCRIPTION	REQ.
2	3SK3620	1/2" X 2 1/2" NC Capscrew (2 required per side)	4
3	3SK3610	1/2" X 2" NC Capscrew (2 required per side)	4
1	3SK3600	1/2" X 1 1/2" NC Capscrew (6 required per side)	12
4	3SK3700	5/8" X 2" NC Capscrew (4 required per side)	8
6	3SK3670	1/2" Locknut (10 required per side)	20
5	3SK3681	5/8" Locknut (4 required per side)	8

F-450/550 MOUNTING KIT 1999-2004

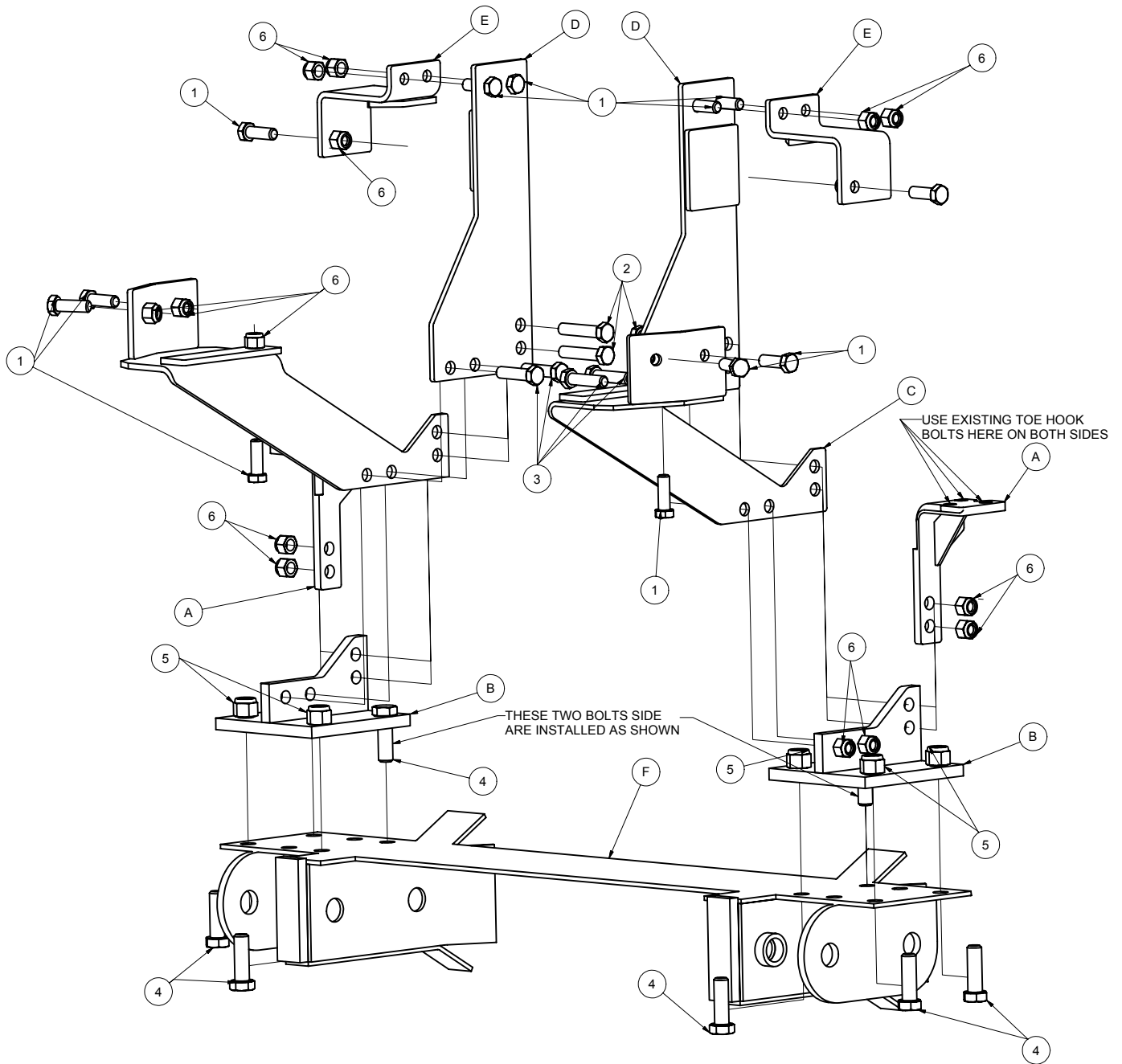

NOTES: ITEM NUMBERS "A" THRU "E" ARE SOLD AS ONE KIT SK1520 OR SK1521 ITEM NUMBER "F" IS NOT

NOTES: IF YOU HAVE A 2004 MODEL REQUEST BLOCKER BEAM MODIFICATION SHEET

ITEM	DRAWING NO.	ALT. ITEM NO.	DESCRIPTION	QTY
A	SK1520/1521		RIGHT/LEFT HAND "A" BRACKET	2
B	SK1520/1521		RIGHT/LEFT HAND RECIEVER MOUNTING BRACKET	2
C	SK1520/1521		RIGHT/LEFT HAND TAILPIECE BRACKET	2
D	SK1520/1521		RIGHT/LEFT HAND SIDE PLATE	2
E	SK1520/1521		RIGHT/LEFT HAND "E" BRACKET	2
F	SK2210		RECIEVER BRACKET	1
1	3SK3600		BOLT HEX 1/2 X 1 1/2 UNC ZINC	12
2	3SK3620		BOLT HEX 1/2 X 2 1/2 UNC ZINC	4
3	3SK3610		BOLT HEX 1/2 X 2 UNC ZINC	4
4	3SK3700		BOLT HEX 5/8 X 2 UNC ZINC	8
5	3SK3781		NUT HEX TOPLOCK 5/8 UNC ZINC	8
6	3SK3670		NUT HEX TOPLOCK 1/2 UNC ZINC	20

2000-2004 FORD SUPER DUTY Installation Instructions – F250/350

1. Remove front bumper saving the fasteners for re-installation.
2. Remove clamp holding power steering cooler lines to radiator support.
3. Remove and relocate power steering cooler toward the drivers' side approximately 6" and re-install with self-tapping screws. (Request drawing to show cooler location.)
4. Install plastic split tubing or a similar insulating/protection type material onto lower portion of each cooler line and secure with wire ties.
5. Install a 1½" insulated frame hose support clamp to the side of radiator support as shown in illustration (pg. 14) and fasten with self-tapping screw.
6. Remove tow hook fasteners and install left and right tow hook post brackets "A" utilizing the original fasteners and tow hooks. Due to possible casting irregularities of front spring hanger, it may be necessary to radius the corners of bracket "A" to insure complete base surface contact within the spring hanger pocket. (Leave bracket fasteners slightly loose for further assembly and final alignment check.)
7. Drill drivers side thrust arm "C" as shown in illustration on page 14.
8. Install frame plates "D" thrust arms "C" and receiver pads "B" onto corresponding sides utilizing ½" X 2½" and ½" X 2" bolts with locking nuts as shown in illustration. Install ½" X 1½" bolts with locking nuts thru bracket "C" sway bar tabs to existing frame sway bar brackets. Using the frame pad outside plates as a guide, drill 17/32" holes thru frame rails. Insert ½" X 1½" bolts with locking nuts. (Leave bracket fasteners slightly loose for further assembly and final alignment check)
9. Install over frame brackets "E" onto frame plates "D" with ½" X 1½" bolts with the bracket hole as a guide, drill 17/32" holes thru the frame rails and insert ½" X 1½" bolt with the locking nut as shown in illustration. (Leave bracket fasteners slightly loose for further assembly and final alignment check.)
10. Position receiver plate "F" onto receiver pads "B" and install with 5/8" X 2" bolts and locking nuts. Insert 3 bolts upward and 1 bolt down per side as shown in illustration.
11. Verify proper frame contact and alignment of all components at this time. Adequately tighten the following fasteners in this sequence:
 - (6) Original.....Metric tow hook bolts
 - (8) ½" X 1½".....Thrust arm bolts
 - (8) 5/8" X 2".....Receiver plate bolts
 - (4) ½" X 2½"Front receiver pad bolts
 - (4) ½" X 2".....Rear receiver pad bolts
 - (5) ½" X 1½".....Over frame bracket bolts
12. Clamp properly re-located and insulated power steering hoses onto thrust arm "C" (drivers side only) utilizing original attachment clamp.
13. Install lift frame release pins, springs and cotter pins into receiver plate "F".
14. Re-install and properly adjust bumper utilizing the original fasteners.

2000-2004 FORD SUPER DUTY Installation Instructions – F450/550

1. Remove front bumper saving the fasteners for re-installation.
 2. Remove clamp holding power steering cooler lines to radiator support.
 3. Remove and relocate power steering cooler toward the drivers' side approximately 6" and re-install with self-tapping screws. (Request drawing to show cooler location.)
 4. Install plastic split tubing or a similar insulating/protection type material onto lower portion of each cooler line and secure with wire ties.
 5. Securely fasten cooler lines utilizing a 1½" insulated frame hose support clamp to the side radiator support as shown in illustration (pg. 14) with a self tapping screw.
 6. Remove tow hook fasteners and install left and right tow hook post brackets "A" utilizing the original fasteners and tow hooks. Due to possible casting irregularities of front spring hanger, it may be necessary to radius the corners of bracket "A" to insure complete base surface contact within the spring hanger pocket. (Leave bracket fasteners slightly loose for further assembly and final alignment check.)
 7. Drill drivers side thrust arm "C" as shown in illustration on page 14.
 8. Install frame plates "D" thrust arms "C" and receiver pads "B" onto corresponding sides utilizing ½" X 2½" and ½" X 2" bolts with Locking nuts as shown in illustration. Install ½" X 1½" bolts with locking nuts thru bracket "C" sway bar tabs to existing frame sway bar brackets. Using the frame pad outside plates as a guide, drill 17/32 holes thru frame rails. Insert ½" X 1½" bolts with locking nuts. (Leave bracket fasteners slightly loose for further assembly and final alignment check)
 9. Install over frame brackets "E" onto frame plates "D" with ½" X 1½" bolts with the bracket hole as a guide, drill 17/32" holes thru the frame rails and insert ½" X 1½" bolt with the locking nut as shown in illustration. (Leave bracket fasteners slightly loose for further assembly and final alignment check.)
 10. Position receiver plate "F" onto receiver pads "B" and install with 5/8" X 2" bolts and locking nuts. Insert 3 bolts upward and 1 bolt down per side as shown in illustration.
 11. Verify proper frame contact and alignment of all components at this time. Adequately tighten the following fasteners in this sequence:
 - (6) Original.....Metric tow hook bolts
 - (8) 5/8" X 2".....Receiver plate bolts
 - (6) ½" X 1 ½".....Thrust arm bolts
 - (4) ½" X 2 ½".....Front receiver pad bolts
 - (4) ½" X 2".....Rear receiver pad bolts
 - (6) ½" X 1 ½".....Over frame bracket bolts
 12. Clamp properly re-located and insulated power steering hoses onto thrust arm "C" (drivers side only) utilizing original attachment clamp.
 13. Install lift frame release pins, springs and cotter pins into receiver plate "F".
- Re-install and properly adjust bumper utilizing the original fasteners.

INSTRUCTIONS FOR INSTALATION ON 1999-2004 FORD'S

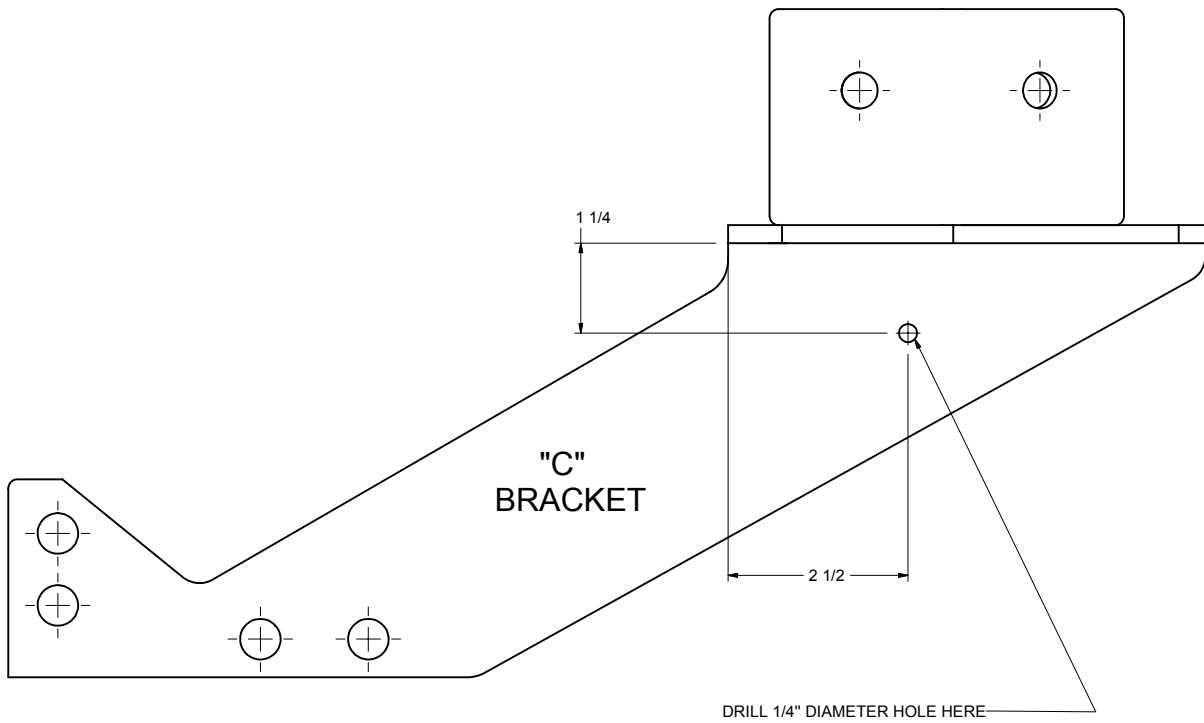

DRIVER'S SIDE "C" BRACKET

2005 FORD SUPER DUTY Installation Instructions – F250/350 &F450/550

1. Remove front bumper saving the fasteners for re-installation.
2. Remove tow hook fasteners.
3. Drop out blocker beam.
4. Install left and right attaching brackets utilizing the original fasteners and tow hooks. Also at this time install one 5/8" X 2" in hole 6" behind 3 tow hook bolts.
5. Install four 1/2" X 1 1/2" bolts on side plate.
6. Position receiver plate "F" onto receiver pads and install with 5/8" X 2" bolts and locking nuts. Insert three bolts upward and one bolt down per side as shown in illustrations.
7. Verify proper frame contact and alignment of all components at this time. Adequately tighten the following fasteners in this sequence:
 - (6) Original metric tow hook bolts
 - (2) 5/8" X 2" bolts behind tow hook bolts
 - (8) 1/2" X 1 1/2" bolts on side plate
 - (8) 5/8" X 2" bolts connecting receiver to Attaching kit
8. Install lift frame release pins, springs, and cotter pins into receiver plate "F".
9. Re-install and properly adjust bumper utilizing the original fasteners.

2005 FORD ATTACH KIT

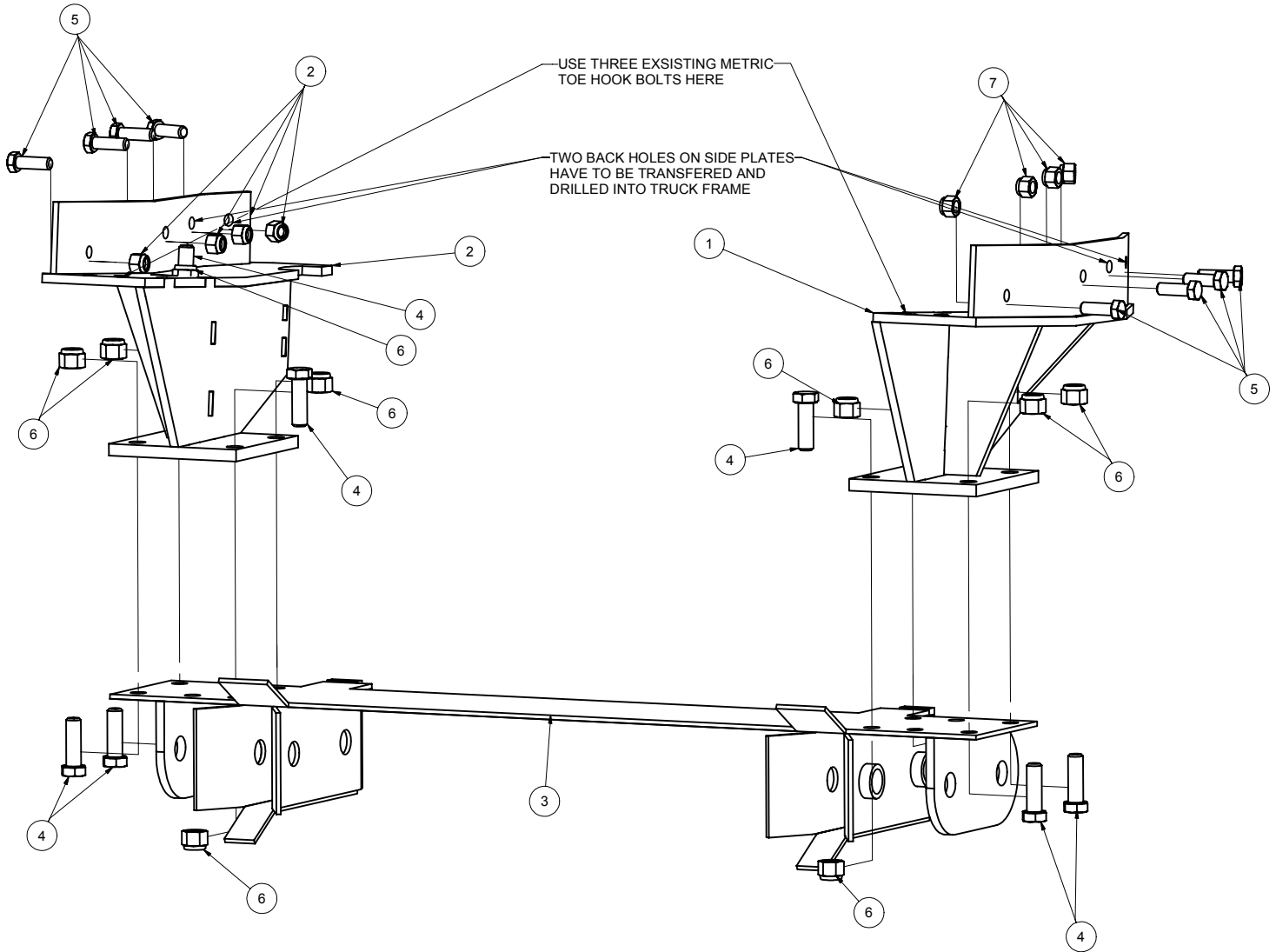

NOTES: ITEM NUMBER 3 IS NOT INCLUDED IN KIT 3SK1522.

ITEM	DRAWING NO.	ALT. ITEM NO.	DESCRIPTION	QTY
1	3SK1522		DRIVERS SIDE	1
2	3SK1522		PASSENGER SIDE	1
3	3SK2210		RECIEVER BRACKET	1
4	3SK3700		BOLT HEX 5/8 X 2 UNC ZINC	10
5	3SK3600		BOLT HEX 1/2 X 1 1/2 UNC ZINC	8
6	3SK3781		NUT HEX TOPLOCK 5/8 UNC ZINC	10
7	3SK3670		NUT HEX TOPLOCK 1/2 UNC ZINC	8

SNO-KING MOLDBOARD / PUSHFRAME ASSEMBLY INSTRUCTIONS

1. Position the moldboard assembly face down on a flat surface.
2. Remove the factory installed 1" and 3/4" fasteners from the left and right torque arm assemblies.
3. Utilizing adequate lifting equipment and proper safety procedures, position the torque tube and a-frame assembly into the rear moldboard cavity and attach with the 1" X 2 1/2" fine thread bolts and flat washers, (a coating of premium grade anti-seize thread compound is recommended) but do not completely tighten at this time.
4. Rotate the torque tube and a-frame assembly towards the moldboard and attach, but do not completely tighten at this time, the torque arms to the center moldboard rib adjusting holes with the 3/4" X 2 1/2" bolts and nuts while positioning the flat washers on the moldboard side of the ribs.
5. Apply thread sealant onto the 90-degree pipe fittings and install into the moldboard reversing cylinders.
6. Attach the correct reversing cylinder hose assemblies as indicated in the parts and service manual for your hydraulic application. A cushion valve is required on all central hydraulic systems. (Please note memo on the following page)
7. Connect each end of the lift chain assembly to the a-frame lifting lugs with the 3/8" clevis midlinks provided.

Once the completed plow assembly has been properly installed on the truck it will be necessary to adjust the moldboard to an angle of attack of 22-25 degrees and adequately tighten both the torque tube and torque arm fasteners at that time.

SNO-KING CUSHION VALVES WITH CENTRAL HYDRAULIC SYSTEMS

A cushion valve is *always* required in the reverse circuit of a Sno-King snowplow!

When you purchase a package which includes an electric / hydraulic power unit, a relief valve is an integral part of the power unit reverse valve.

When you purchase a Sno-King light duty package less hydraulics (3SK0110, 3SK0210, 3SK0310) no cushion valve is included in the package – we consider them to be a part of the hydraulic package. A cushion valve for reverse cylinder protection must be included in your hydraulic package or certain cylinder failure will result. We recommend a cushion valve with a relief setting between 2250 – 2500 psi (maximum working pressure of the reverse cylinder is 2500 psi).

The majority of our Dealers have opted to supply their own cushion valves. Sno-King will make an optional cushion valve available to those of you that wish to purchase them from us.

MAINTENANCE PROCEDURE:
Tightening Packing Nuts on Snowplow Cylinders

Adjusting packing nuts are used on snowplow cylinders to hold the cylinder together as well as providing pressure against the chevron style rod packing. As the nut is tightened, the v-shaped packing flare out and seal tightly against the rod surface.

Often times, it is necessary to adjust the packing nut in the field if oil starts to leak from the cylinder. This occurs because the seals tend to wear in after 100 cycles and need to have more pressure applied to them.

The proper adjustment procedure for the packing nut is listed below:

- 1) Loosen the packing nut.
- 2) Tighten the packing nut by hand until it is snug against the packing.
- 3) Use a nut wrench to tighten the nut $\frac{3}{4}$ turn.

This simple procedure should produce a torque value on the nut of 50 foot-pounds and should provide a dry rod when cycled.

TORQUE ARM REMOVAL

- Proper torque arm removal is accomplished by pulling the arms from the torque tube assembly via the threaded portion of the inner shaft. Never attempt to pound out the arms, as the arms will be damaged. To install the arms, adequately lubricate the inside of the torque tube, the outside of the torque arms, and press the arms into the torque tube while protecting the threads.
-
- Please contact Craig at 319-236-7977 if you have any questions.

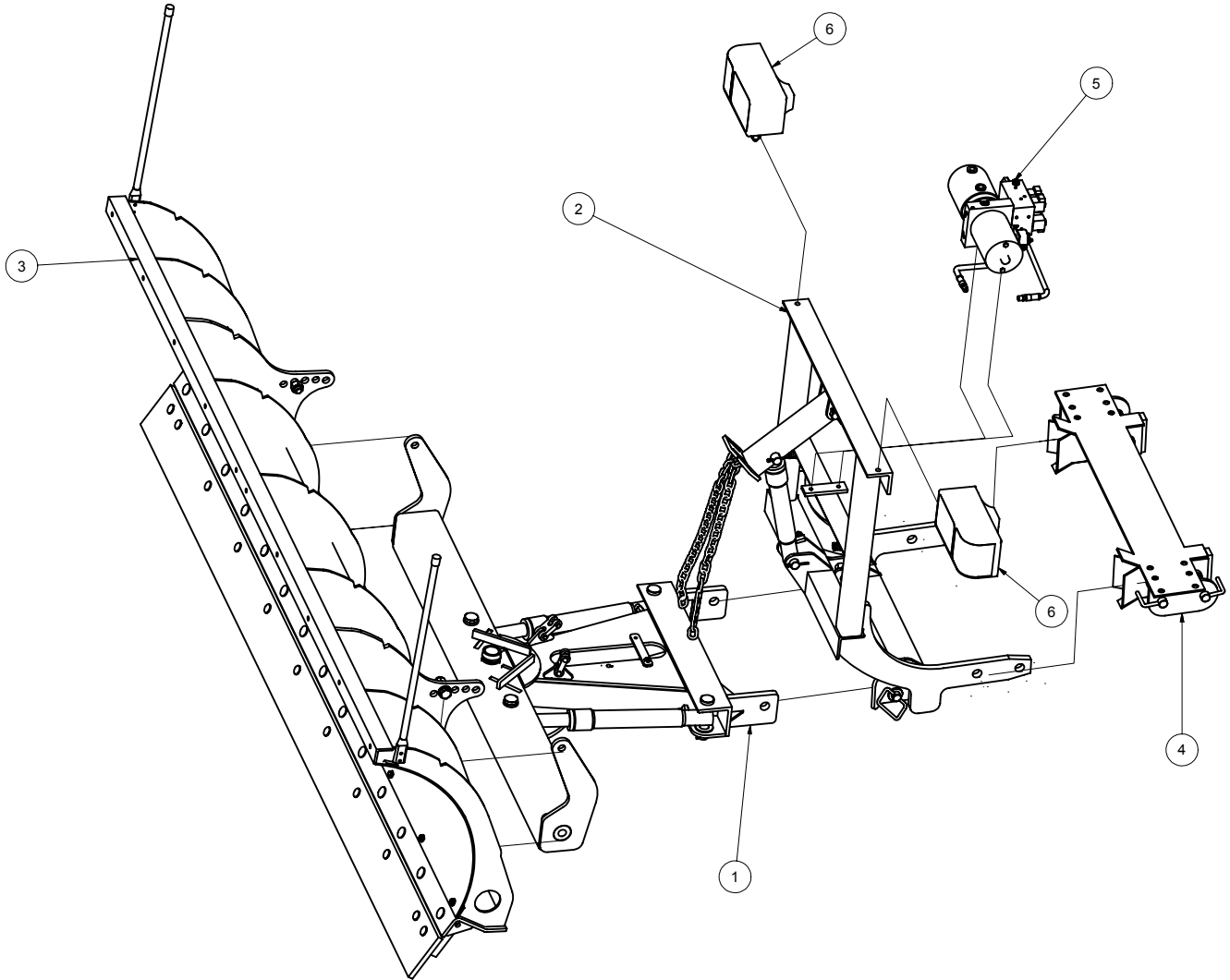

ITEM	DRAWING NO.	ALT. ITEM NO.	DESCRIPTION	QTY
1	3SK2160-1		"A" FRAME FOR 8', 9', & 10' LD MODLES	1
2	3SK2200		LIFT FRAME HITCH FOR 8', 9', & 10' LD	1
3	SK2115		8', 9', & 10' POLY MOLDBOARD FRAME	1
4	3SK2210		LIGHT DUTY RECIEVER	1
5	3SK4056M		ELECTRIC HYDRAULIC POWER UNIT	1
6	SK6010TLN		PLOW LIGHTS	2

**SNO-KING LIFT FRAME / HITCH PARTS
FOR 8', 9', and 10' LD MODELS**

REF NO.	PART NO.	DESCRIPTION	REQ.
1	3SK2200	Lift Frame / Hitch for 8', 9', and 10'LD Models	1
2	3SK2220	Lift "Arm"	1
13	3SK3411	Cotter Hair Pin 3/16" X 3¾" Zinc	3
6	3SK3411	1" X ¾" Handle Pin	2
7	3SK3400	1" X ½" Pin	1
8	3SK3410	1" X 4" Pin	2
5	3SK4056M	Power Unit	1
	3SK4120	¼" 90-Degree Swivel	3
	3SK4073	¼" X 22½" Hose Assembly	1
	3SK4071	¼" X 12" Hose Assembly	2
3	3SK4000	Cylinder, 1½" X 8" SA	1
	3SK3480	Spring-Loaded Pin (See illustration on page 2&4)	4
12	3SK3450	Cotter Pin 3/16" X 2½" Zinc	2
	3SK3460	Hair Pin Clip	1
9	2S20A-2	¼" Quick Disconnect Set	2
	3SK3660	½" Flat washer (spacers)	2
	3SK4170	¼" Dust Cover Socket	1
	3SK4180	¼" Dust Cover Nipple	1
10	3SK3587HC	Hi Lock washer Split 3/8" Zinc	2
11	3SK3586	Capscrew Socket Head 3/8" X 1" NC Black	2

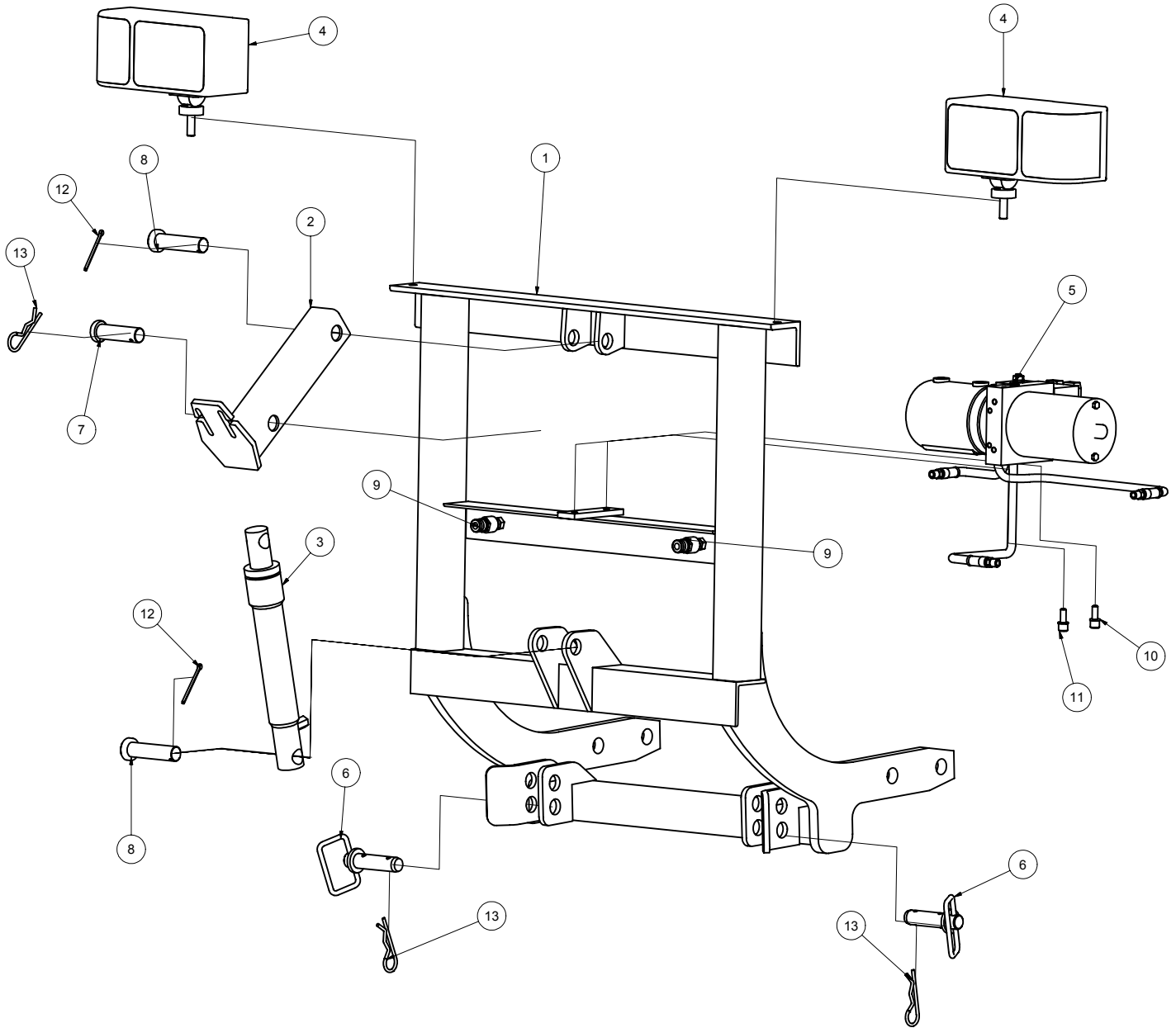

ITEM	DRAWING NO.	ALT. ITEM NO.	DESCRIPTION	QTY
1	SK2200		LIFT FRAME HITCHFOR 8', 9', & 10' LD	1
2	SK2220		LIFT YOKE or "ARM"	1
3	SK4000		LIFT CYLINDER 1 1/2" X 8"	1
4	SK6010TLN		PLOW LIGHTS	1
5	3SK4056M		ELECTRIC HYDRAULIC POWER UNIT	1
6	3SK3411		HANDLE PIN 1" X 3 3/4"	2
7	3SK3400		PIN 1" X 3 1/2"	1
8	3SK3410		PIN 1" X 4"	2
9	2S20A-2		QUICK COUPLING 1/4"	2
10	3SK3587HC		HI LOCKWASHER SPLIT 3/8 ZINC	2
11	3SK3586		CAP SCREW SOCKET HEAD 3/8 X 1 NC BLACK	2
12	3SK3450		COTTER PIN 3/16 X 2 1/2 ZINC	2
13	3SK3411		COTTER HAIRPIN 3/16 X 3 3/4 ZINC	3

**SNO-KING MODEL DT 8' LD PLOW
MOLDBOARD ASSEMBLY LIST**

REF NO.	PART NO.	DESCRIPTION	REQ.
1	3SK2100	8' Steel Moldboard	1
1	3SK2105	8' Poly Moldboard *	1
2	3SK7055	8' Ploy Sheet *	1
14	3SK3585	3/8" X 1½" Bolt *	20
17	3SK3591	3/8" Top Lock Nut *	20
18	3SK3595	3/8" Flat Washer *	20
3	3SK7102	Cutting Edge, 5/8"W X 6"H X 96"L Std Highway punching	1
6	3SK7164	Plate Washer 18"	4
13	3SK3698	5/8" x 1½" Bolt	6
12	3SK3720	5/8" X 3" Grade 5 Carriage Bolt	9
10	3SK3722	5/8" X 3½" Grade 8 Bolts	3
11	2N81074	5/8" X 3" Plow Bolts	10
19	3SK3768	5/8" X 2½" O.D. Washer	10
16	3SK3781	5/8" Top Lock Nut	22
5	3SK2281	Hinge Stop with fasteners	2
4	3SK7051	96" Adiprene™ Trip Hinge	1
9	3SK7020	28" Plow Marker with installation hardware –pair	1
8	3SK2285	Curb Shoe	1
 <u>Options:</u>			
(Pg 29)	3SK7130	8' Rubber Deflector with installation hardware	1
	3SK2280	Skid Shoe with Spacer and Linchpin	2
	3SK3835	Skid Shoe Adjusting Washers	32

*Used on 8' Poly Moldboard Only.

SNO-KING MODEL DT 9' LD PLOW MOLDBOARD ASSEMBLY LIST

REF NO.	PART NO.	DESCRIPTION	REQ.
1	3SK2110	9' Steel Moldboard	1
1	3SK2115	9' Poly Moldboard *	1
2	3SK7066	9' Ploy Sheet *	1
14	3SK3585	3/8" X 1½" Bolt *	20
17	3SK3591	3/8" Top Lock Nut *	20
18	3SK3595	3/8" Flat Washer *	20
3	3SK7112	Cutting Edge, 5/8"W X 6"H X 108"L Std. Highway punching	1
6	3SK7164	Plate Washer 18"	4
7	3SK7165	Plate Washer 10"	1
13	3SK3698	5/8" x 1½" Bolt	6
12	3SK3720	5/8" X 3" Grade 5 Carriage Bolt	11
10	3SK3722	5/8" X 3½" Grade 8 Bolts	3
11	2N81074	5/8" X 3" Plow Bolts	11
19	3SK3768	5/8" X 2½" OD Washer	11
16	3SK3781	5/8" Top Lock Nut	25
5	3SK2281	Hinge Stop with fasteners	2
4	3SK7061	108" Adiprene™ Trip Hinge	1
9	3SK7020	28" Plow Marker with installation hardware –pair	1
8	3SK2285	Curb Shoe	1

Options:

(Pg 29)	3SK7130	9' Rubber Deflector with installation hardware	1
	3SK2280	Skid Shoe with Spacer and Linchpin	10
	3SK3835	Skid Shoe Adjusting Washers	3

* Used on 9' Poly Moldboard Only.

SNO-KING MODEL DT 10' LD PLOW MOLDBOARD ASSEMBLY LIST

REF NO.	PART NO.	DESCRIPTION	REQ.
1	3SK2121	10' Steel Moldboard	1
1	3SK2125	10' Poly Moldboard *	1
2	3SK7076	10' Ploy Sheet *	1
14	3SK3585	3/8" X 1½" Bolt *	24
17	3SK3591	3/8" Top Lock Nut *	24
18	3SK3595	3/8" Flat Washer *	24
3	3SK7121	Cutting Edge, 3/4"W X 6"H X 120"L Std. Highway punching	1
	3SK7166	Plate Washer 26" Upper (not shown)	3
	3SK7167	Plate Washer 6" Upper (not shown)	2
13	3SK3698	5/8" x 1½" Bolt (not shown)	6
12	3SK3720	5/8" X 3" Grade 5 Carriage Bolt	10
10	3SK3722	5/8" X 3½" Grade 8 Bolt	3
19	3SK3768	5/8" X 2½" O.D. Washer	12
16	3SK3781	5/8" Top Lock nut	25
11	2N81074	5/8" X 3" Plow Bolt	12
5	3SK2281	Hinge Stop with fasteners	2
4	3SK7071	120" Adiprene™ Trip Hinge	1
9	3SK7030	36" Plow Marker with installation hardware – pair	1
8	3SK2286	Curb Shoe	1

Options:

(Pg 29)	3SK7150	10' Rubber Deflector with installation hardware	1
	3SK2280	Skid Shoe with Spacer and Linchpin	2
	3SK3835	Skid Shoe Adjusting Washers	32

*Used on 10' Poly Moldboard Only.

9' STEEL MOLDBOARD ASSEMBLY

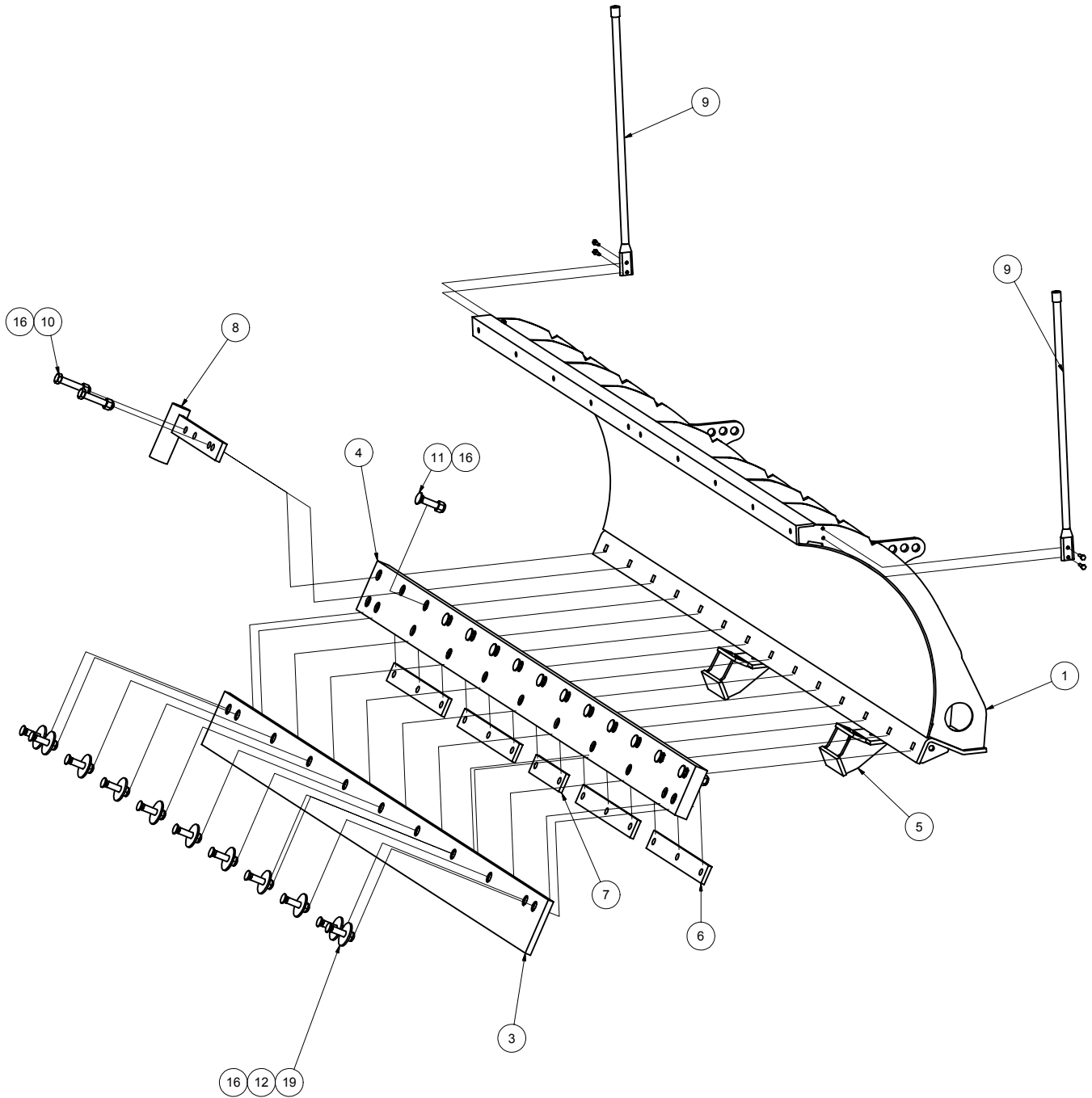

9' POLY MOLDBOARD ASSEMBLY

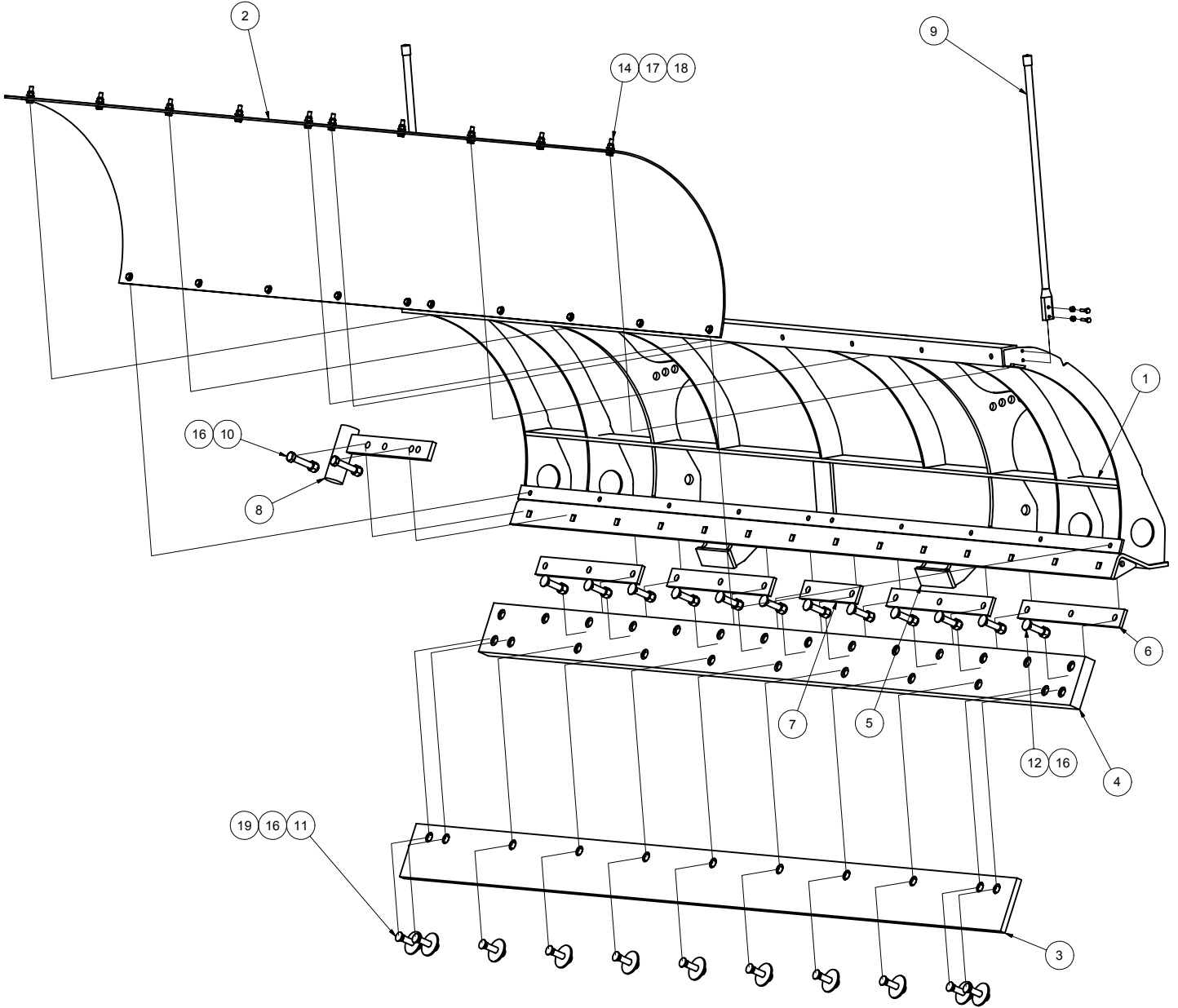

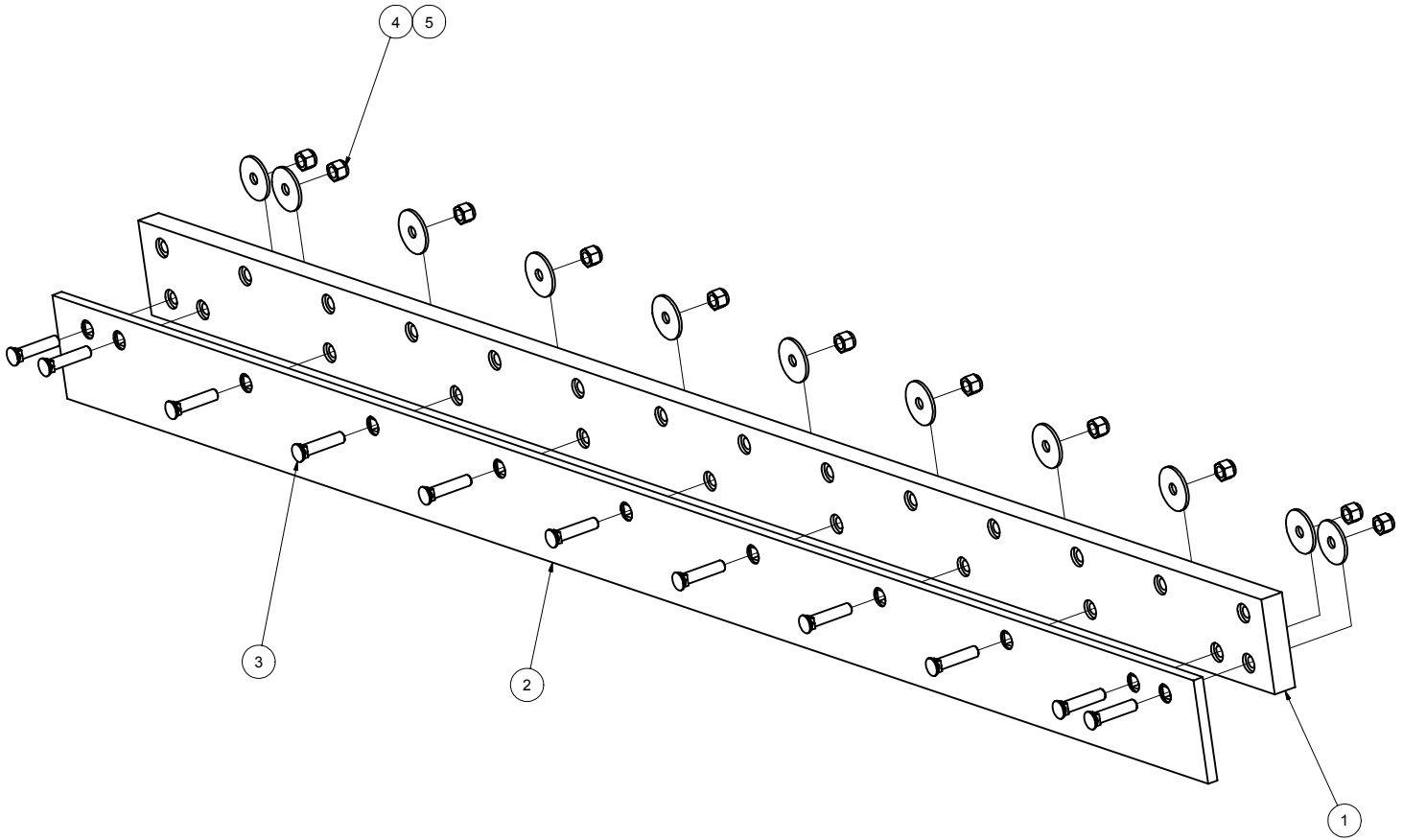

NOTES: DON'T USE CUTTING TORCH TO REMOVE BOLTS WHEN CHANGING CUTTING EDGE. IT WILL RUIN ADIPRENE HINGE.

NOTES: ALWAYS USE NEVER SEIZE ON ALL BOLTS WHEN REINSTALLING REPLACEMENT BLADES

ITEM	DRAWING NO.	ALT. ITEM NO.	DESCRIPTION	QTY
1	3SK7061		ADIPRENE TRIP HINGE	1
2	SK7112		CUTTING EDGE STD HIGHWAY PUNCHING	1
3	3SK3725		5/8 X 3 GRADE 5 CARRIAGE BOLT	11
4	3SK3781		NUT HEX TOPLOCK 5/8 UNC ZINC	11
5	3SK3768		5/8 X 2 1/2 O.D. WASHER	11

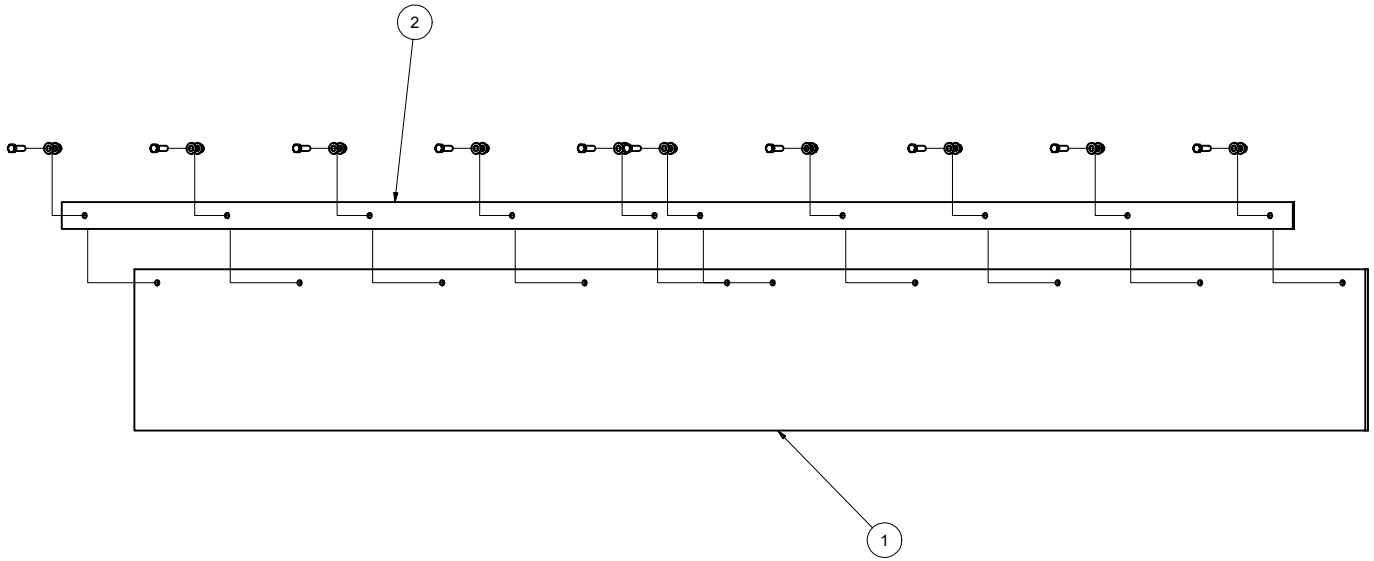

NOTES: ALL ITEMS ARE OPTIONAL FOR 8', 9', & 10' MOLDBOARDS

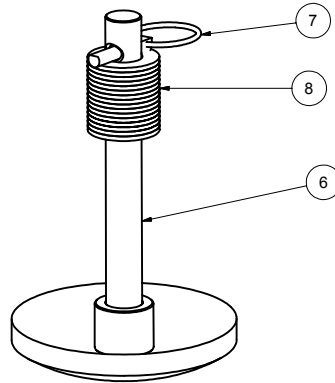

ITEM	DRAWING NO.	ALT. ITEM NO.	DESCRIPTION	QTY
1	SK7140		RUBBER DEFLECTOR	1
2	3SK7156		RETAINER STRIP	1
6	SK2280		SKID SHOE	2
7	SK2280		HITCH PIN 3/16"	2
8	SK2280		FLATWASHER SAE 1 ZINC	32
9	3SK3585		BOLT HEX 3/8 X 1 1/2 UNC ZINC	10
10	3SK3595		FLATWASHER SAE 3/8 ZINC	20
11	3SK3591		NUT HEX TOPLOCK 3/8 UNC ZINC	10

SNO-KING MODEL DT 8', 9', 10' LD "A" FRAME / PUSHFRAME ASSEMBLY LIST

REF NO.	PART NO.	DESCRIPTION	REQ.
1	3SK2160-1	"A" Frame for 8', 9' and 10' Models	1
2	3SK2130	Torque Tube Universal	1
3	3SK2155L	Tripping Torque Arm (left)	1
4	3SK2155R	Tripping Torque Arm (right)	1
5	3SK4010	Cylinder, 1½" X 10" SA (8' and 9')	2
	3SK4020	Cylinder, 2" X 10" SA (10' L.D.)	2
6	3SK3489	Mid Link – used with chain	2
7	3SK4120	¼" 90-Degree Swivel Adapter	2
8	3SK3490	6'6" X 5/16" Chain	1
9	3SK3441	1½" X 7 ¾" Pin with Snap Ring (used in center of torque tube)	1
10	3SK3431	1" X 6" Pin (used in torque tubes)	2
11	3SK3420	1" X 5" Pin	2
12	3SK3830	1" X 2½" Grade 8 Bolt, Fine Thread	2
13	3SK3800	¾" X 2½" Grade 8 Bolt	2
14	3SK3835	1" USS Flat Washer	4
15	3SK3820	¾" Washer	2
16	3SK3811	¾" Top Lock Nut	2
17	3SK3450	Cotter Pin (2 for 5" pins and 2 for 6" pins listed above)	4
18	3SK4080	¼" X 33" Hose Assembly-for electric hydraulics (See option below)	2
	3SK2290	Insta-Shoe (not shown)	1
	2S20A-2	¼" Quick Disconnect Set (not shown)	1
<u>Options:</u>			
	3SK4090	¼" X 40" Hose – for central hydraulics	2

LIGHT DUTY PUSH FRAME ASSEMBLY

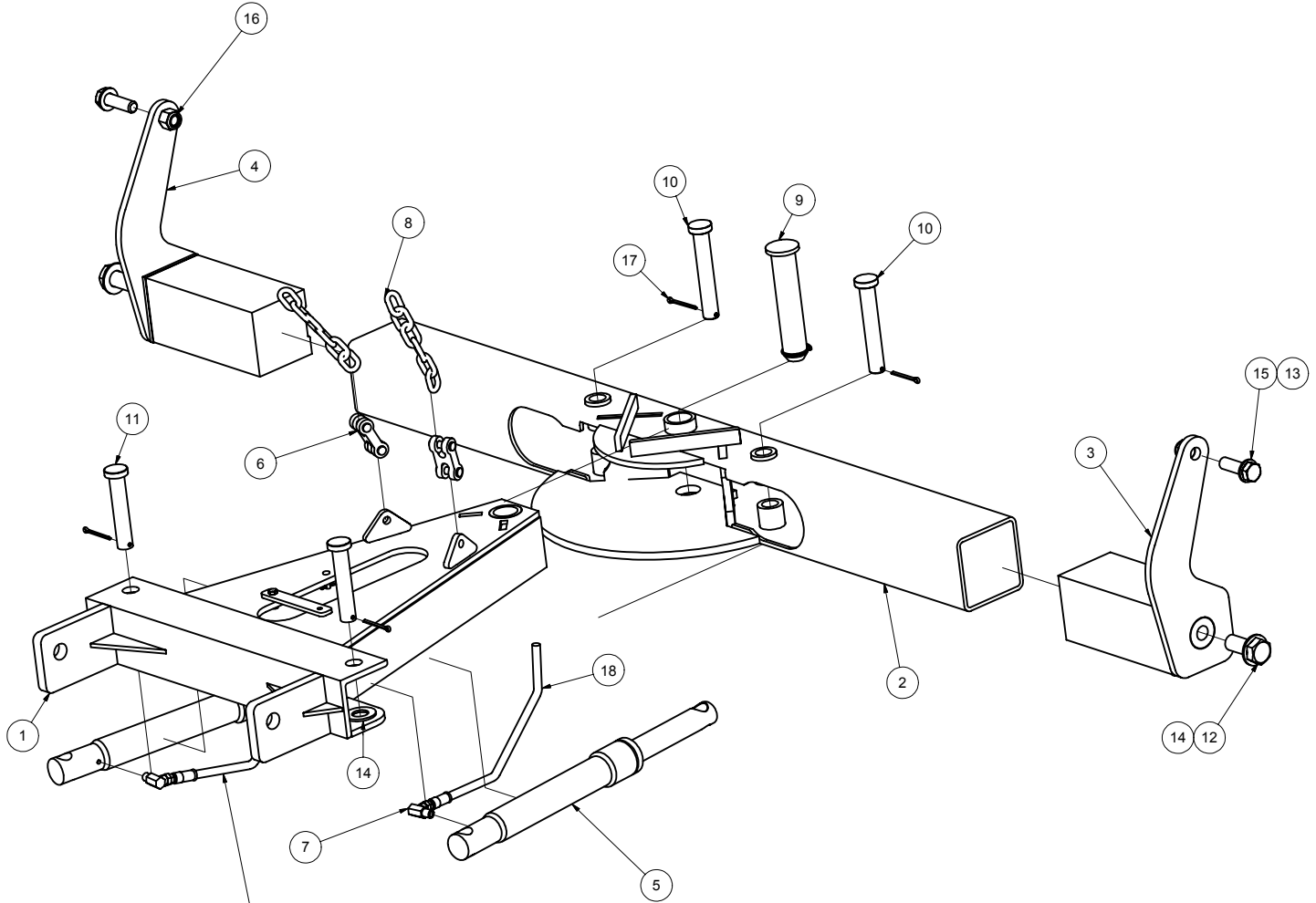

ITEM NUMBER 19 IS NOT SHOWN
ONLY ORDERED IF YOU ARE USING
CENTRAL HYDRAULICS

OPTIONAL: 2 X 10 REV CYLINDER AVAILABLE
FOR 10' MOLDBOARDS (PART #3SK4020)

ITEM	DRAWING NO.	ALT. ITEM NO.	DESCRIPTION	QTY
1	3SK2160		"A" FRAME FOR 8', 9', & 10' LIGHT DUTY MODELS	1
2	SK2130		UNIVERSAL TORQUE TUBE	1
3	SK2155-R		TRIPPING TORQUE ARM	1
4	SK2155-L		TRIPPING TORQUE ARM	1
5	SK4010		REV CYLINDER 1 1/2" X 10" SA	2
6	3SK3489		3/8" MIDLINK	2
7	3SK4120		1/4" 90 DEGREE SWIVEL ADAPTOR	2
8	SK3490		6' 6" X 5/16" CHAIN	1
9	3SK3441		1 1/2 X 7 3/4 PIN WITH SNAP RING	1
10	3SK3431		PIN 1 X 6	2
11	3SK3420		PIN 1 X 5	2
12	3SK3830		BOLT HEX 1 X 2 1/2 SAE ZINC	2
13	3SK3800		BOLT HEX 3/4 X 2 1/2 UNC ZINC	2
14	3SK3835		FLATWASHER SAE 1 ZINC	4
15	3SK3820		FLATWASHER SAE 3/4 ZINC	2
16	3SK3811		NUT HEX TOPLOCK 3/4 UNC ZINC	2
17	3SK3450		COTTER PIN 1/4 X 2 1/2 ZINC	4
18	SK4080		1/4" X 33" HOSE ASSEMBLY FOR ELECTRONIC HYDRAULICS	2
19	SK4090		1/4" X 40" HOSE ASSEMBLY FOR CENTRAL HYDRAULICS	2

INSTA-MOUNT REMOVAL INSTRUCTIONS

1. Put the power controller in the down position.
2. Compress the lift cylinder completely.
3. Remove the snowplow lift chains.
4. Remove the insta-shoe and place it on the ground beneath the holder.
5. Remove both the upper and lower 1” pins on the lift cylinder and invert the cylinder through the holder.
6. Install the cylinder shaft to the insta-shoe by sliding the pin through both. Secure each pin with a lynch pin clip.
7. Re-pin the cylinder barrel to the bottom of the lift ram hole.
8. Reattach the lift chains to the lift arm as tightly as possible. **VERY IMPORTANT:** Failure to attach the chains to the lift arm will allow the headgear to strike the front grill of the truck when backing away from the frame.
9. Press up on the switch on the power distribution box until the headgear lifts slightly after the ram pushes the shoe into the ground.
10. Release and secure the two spring pins on either side of the truck.
11. Place the switch in the neutral position.
12. Disconnect the two electrical connections and lights.
13. Back the truck away from the plow. If the plow frame drags backwards, attach the power supply and adjust the height as needed.

INSTA-MOUNT INSTALLATION INSTRUCTIONS

1. Pull out the spring-loaded pins on either side of the receiver boxes and rotate them to the release position (approximately a $\frac{1}{4}$ " turn).
2. Drive the truck into the lift frame staves after verifying the correct height and alignment.
3. Connect the electrical connections at this time. If the height of the stave is off, raising or lowering it with the power distribution box can adjust this.
4. Release the spring pins. If the pins do not slide in, a slight front to rear rocking on the top of the headgear will cause the pins to bottom out.
5. Place the rocker switch in the down position.
6. Remove the 1" pin holding the lift cylinder to the bottom of the lift. Lift up slightly.
7. Remove the $\frac{5}{8}$ " pin and the insta-shoe.
8. Invert the lift ram to the upward position and re-pin it.
9. Install the insta-shoe in the holder on the pushframes.
10. Reattach the lift chains, keeping the chain links straight.

GENERAL OPERATING INSTRUCTIONS

BEFORE SNOW-PLOWING:

1. Check the pump fluid level with the lift cylinder ram completely down. Keep the fluid level ½” below the filler neck.
2. Check all electrical connections for tightness. Remove any corrosion. Make sure the unit is grounded securely.
3. Carry the emergency repair kit and four quarts of *Dextron III ATF* fluid for commercial operations.
4. Tighten all bolts on the plow and truck hitch. Inspect for leaks and worn cutting edge. Replace if needed.
5. With the cylinder ram completely down, adjust both chains to the tightest position, keeping all the links straight.

DURING SNOW-PLOWING:

2. Adjust the skid shoes to the upper most position on pavement or frozen earth surfaces.
3. Lower the skid shoes to support the cutting edge ¼” above the surface to prevent digging in to thawed earth and “pea stone” surfaces.
4. If any hydraulic leaks occur, stop plowing immediately. Raise the plow with a jack or level. This will enable the vehicle to be driven for repair with the snowplow raised.
5. Inspect the entire snowplow system hourly during plowing.
6. Replace the cutting edge before it wears into the polymer. Remove the cutting edge bolts with proper tools. DO NOT burn-off the bolts, as this will destroy the polymer.
7. DO NOT exceed 5 MPH while snowplowing.

AFTER SNOW-PLOWING:

1. Check all hoses and fittings for leaks.
2. Lubricate the cylinder rams and pins with multi-purpose grease.

SNO-KING LIGHT KIT PARTS LIST

REF NO.	PART NO.	DESCRIPTION	REQ.
1	3SK6010TLN	Plow Lights with Harness (plow light kit) <i>-Includes RH & LH lamp assemblies, RH & LH directional lamps, and installation hardware. Individual parts are not sold separately.</i>	1
2	3SK6110	Ford Specific Adapter Kit-Std Seal Beams	1
	3SK6120	Ford Specific Adapter Kit-Composite Bulbs	1

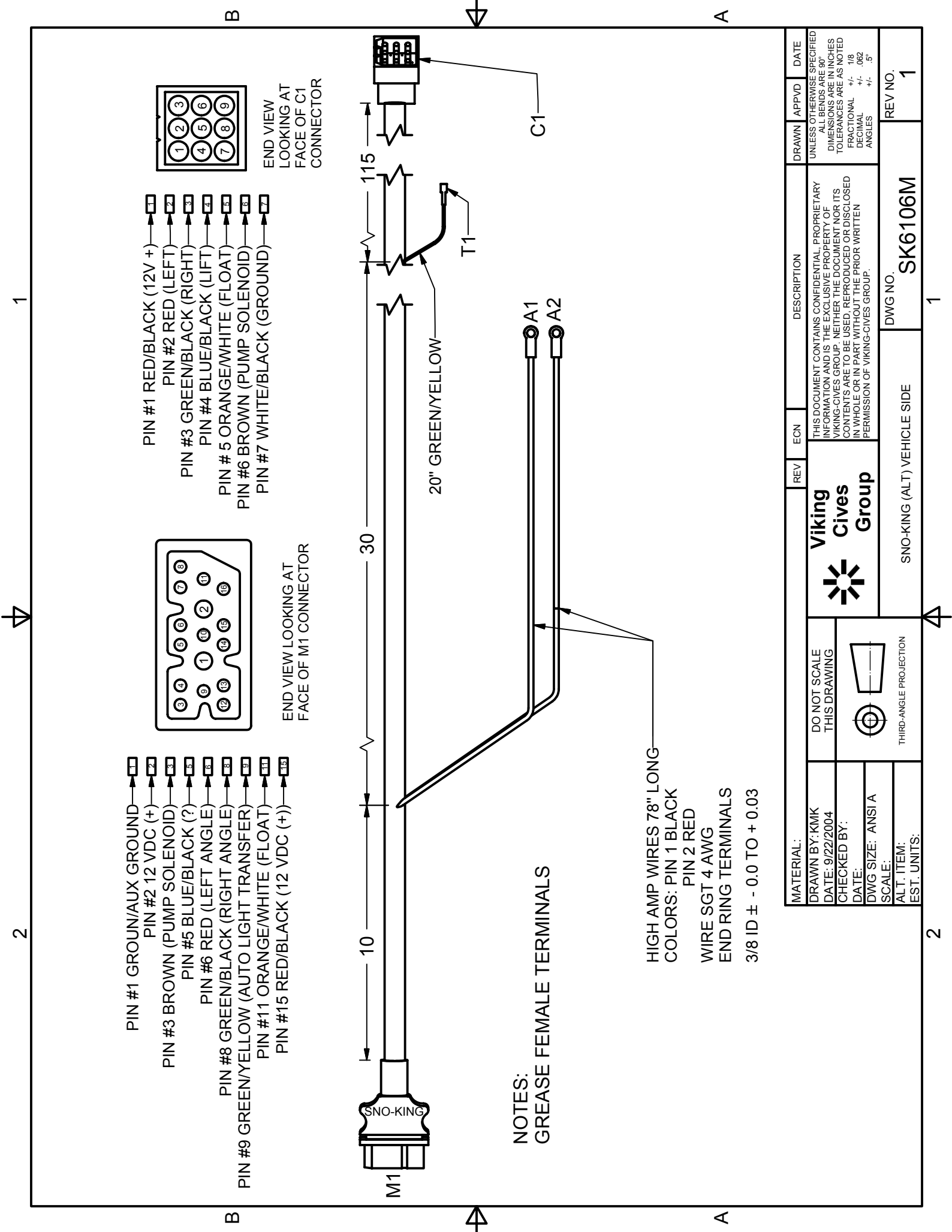

NOTES:
GREASE FEMALE TERMINALS

HIGH AMP WIRES 78" LONG
COLORS: PIN 1 BLACK
PIN 2 RED
WIRE SGT 4 AWG
END RING TERMINALS
3/8 ID ± - 0.0 TO + 0.03

MATERIAL:		REV	ECN	DESCRIPTION	DRAWN	APPVD	DATE
DRAWN BY: KMK		THIS DOCUMENT CONTAINS CONFIDENTIAL, PROPRIETARY INFORMATION AND IS THE EXCLUSIVE PROPERTY OF VIKING-GIVES GROUP. NEITHER THE DOCUMENT NOR ITS CONTENTS ARE TO BE USED, REPRODUCED OR DISCLOSED IN WHOLE OR IN PART WITHOUT THE PRIOR WRITTEN PERMISSION OF VIKING-GIVES GROUP.			UNLESS OTHERWISE SPECIFIED DIMENSIONS ARE IN INCHES TOLERANCES ARE AS NOTED		
DATE: 9/22/2004		VIKING GIVES GROUP			FRACTIONAL ±.18		
CHECKED BY:		SNO-KING (ALT) VEHICLE SIDE			DECIMAL ±.062		
DATE:		DWG NO. SK6106M			ANGLES ±.5°		
DWG SIZE: ANSI A		SNO-KING (ALT) VEHICLE SIDE			REV NO. 1		
SCALE:		THIRD-ANGLE PROJECTION					
ALT. ITEM:		1					
EST. UNITS:		1					

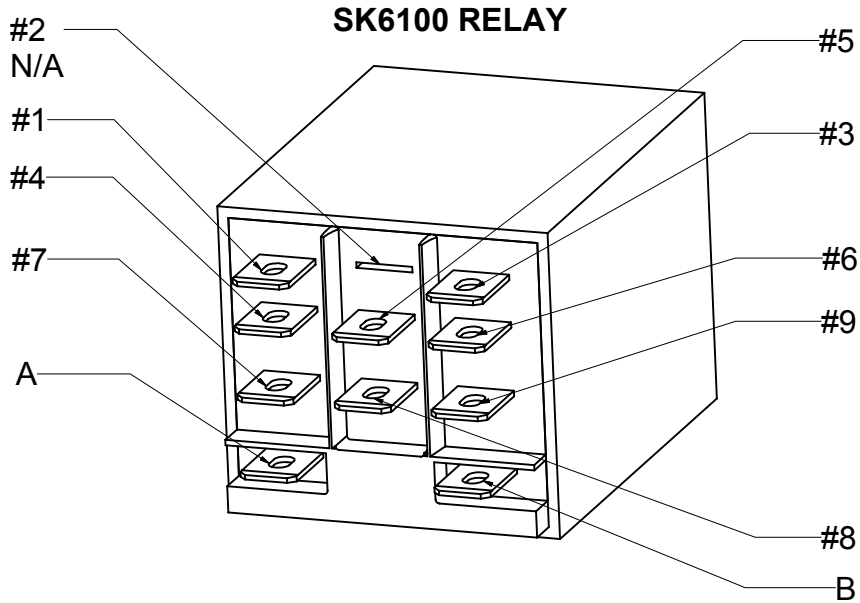

3PDT RELAY (30 AMPS) 12 VOLTS (BLACK)

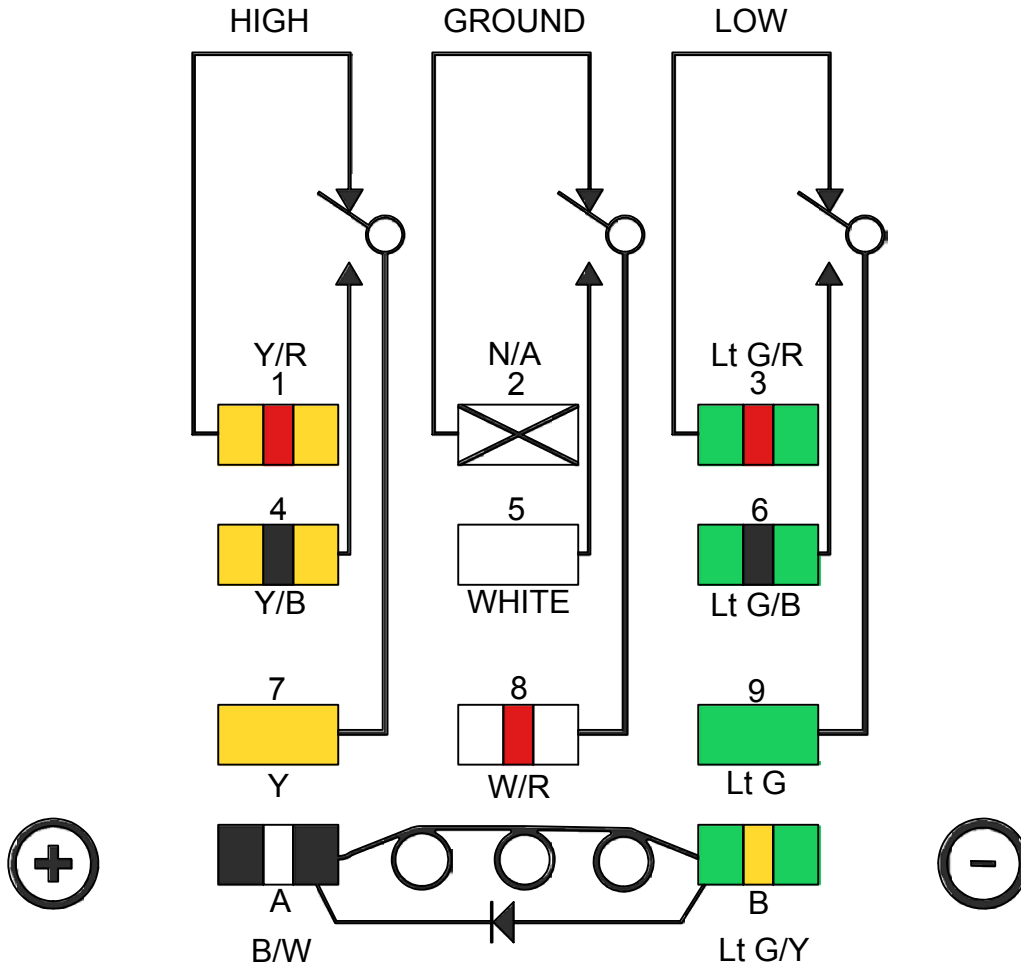

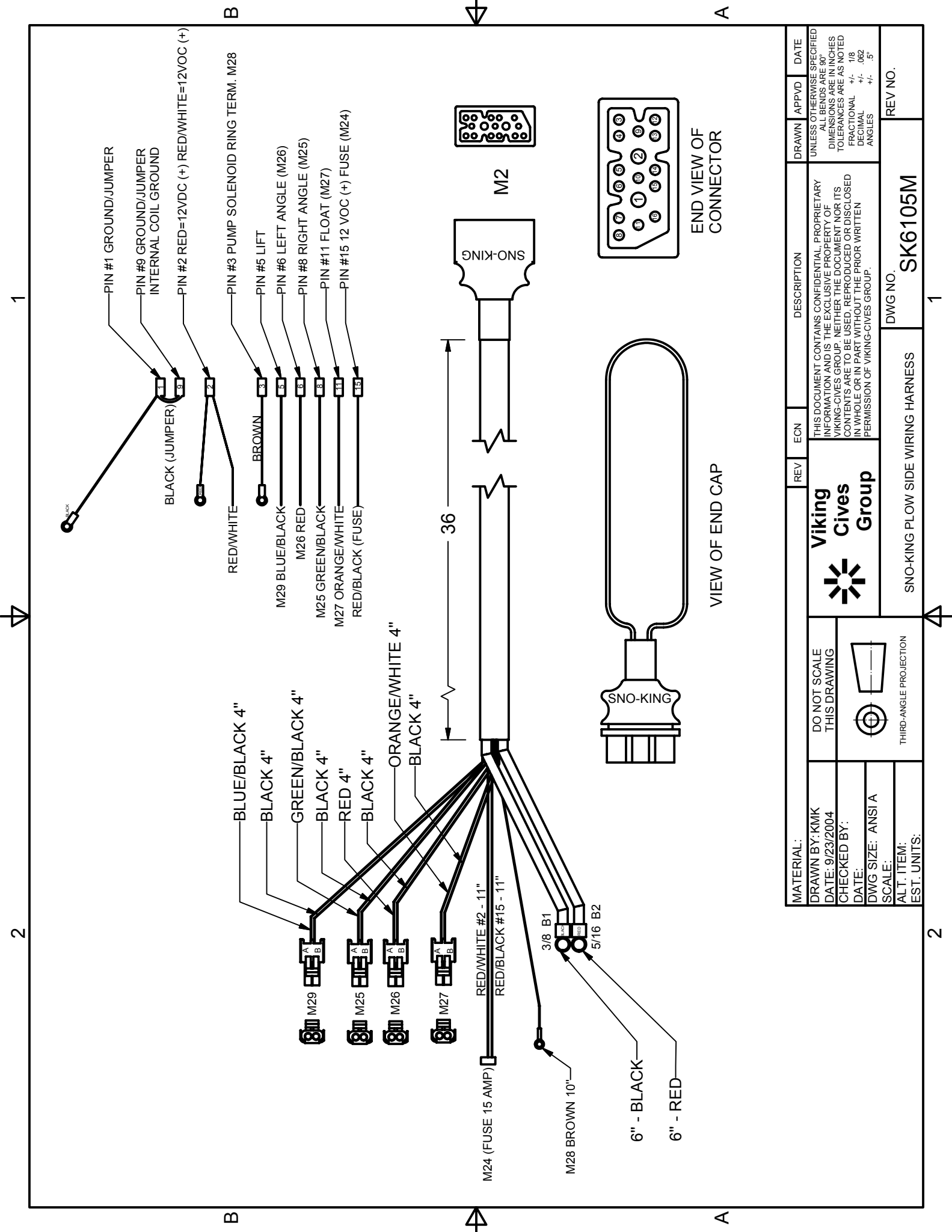

MATERIAL:		REV	ECN	DESCRIPTION	DRAWN	APPVD	DATE
DRAWN BY: KMK		THIS DOCUMENT CONTAINS CONFIDENTIAL, PROPRIETARY INFORMATION AND IS THE EXCLUSIVE PROPERTY OF VIKING-CIVES GROUP. NEITHER THE DOCUMENT NOR ITS CONTENTS ARE TO BE USED, REPRODUCED OR DISCLOSED IN WHOLE OR IN PART WITHOUT THE PRIOR WRITTEN PERMISSION OF VIKING-CIVES GROUP.			UNLESS OTHERWISE SPECIFIED DIMENSIONS ARE IN INCHES TOLERANCES ARE AS NOTED FRACTIONAL .18 DECIMAL .062 ANGLES +/- .5°		
DATE: 9/23/2004		Viking Cives Group			REV NO.		
CHECKED BY:		DO NOT SCALE THIS DRAWING			SK6105M		
DATE:		THIRD-ANGLE PROJECTION			DWG NO.		
DWG SIZE: ANSI A		SNO-KING FLOW SIDE WIRING HARNESS			REV NO.		
SCALE:		1			1		
ALT. ITEM:		1			1		
EST. UNITS:		1			1		

SNO-KING

DIVISION OF VIKING-CIVES GROUP
212 NORTH EVANS ROAD
EVANSDALE, IA 50707
TELEPHONE 319/236-7977

***** LIMITED WARRANTY*****

SNO-KING warrants products of its manufacture against defects in workmanship and material for a period of one year from date of shipment to customer; and in consequence of this warranty, any component part or parts of such products proving defective within the above specified time will be repaired or replaced F.O.B. factory, providing such parts are returned, transportation prepaid, to the factory and found defective by **SNO-KING**. This warranty will not apply to any product which shall have been repaired or altered outside of the **SNO-KING** factory in any way so as, in **SNO-KING** sole judgement, to affect its stability or reliability, nor which has been subjected to misuse, negligence or accident.

The obligations of **SNO-KING** under this limited warranty are limited to the replacement of defective parts as set forth above; such obligations are exclusive and in lieu of all other remedies, warranties, guarantees or liabilities, express or implied, with respect to each product delivered hereunder, arising by law or otherwise (including without limitation any obligation or liability of **SNO-KING**, arising from negligence or with respect to fitness for a particular purpose, merchantability, loss or use, revenue, or profit, or any incidental, indirect, special or consequential damages or injuries, even if **SNO-KING** has been advised of the possibility of such damages or injuries; and all other remedies, warranties, guarantees, or liabilities are hereby expressly excluded and disclaimed. This limited warranty shall not be extended, altered, or varied except by a written instrument signed by **SNO-KING**.

SNO-KING assumes no responsibility for engines, electrical equipment, or any other equipment and accessories not manufactured by **SNO-KING**.