



**FUTURE**  
MOBILITY HEALTHCARE INC.



610 REV01 REV DATE: JAN 1, 2013

**AQUA**  
Rehab Commode  
**NT600**

USER MANUAL

## CONTENTS

1	General.....	3
	Operating Safety Warnings .....	4
	Features.....	5
	Safety Inspection Checklist.....	6
	Troubleshooting .....	8
2	Arms.....	9
3	Back.....	11
	Lifting the Back frame .....	12
	Reinserting the Back frame .....	13
4	Casters .....	14
	Adjusting Casters high and engaging.....	14
	Casters engaging .....	14
5	Seat Installation .....	15
	Installing the Potty .....	16
6	Footrest.....	17
7	Cleaning and maintenance.....	18

## 1 General

**NOTICE:** Information contained within this document is subject to change without notice.

**WARNING:** DO NOT install this equipment without first reading and understanding this instruction booklet. If you are unable to understand these instructions, contact a healthcare professional, dealer or technical personnel before attempting to install this equipment - otherwise, injury or damage may occur.

**NOTE:** Check all parts for shipping damages before using. In case of damage, **DO NOT** use the equipment. Contact the Equipment Supplier for further instructions.

## **Operating Safety Warnings**

Please read and obey all instructions and warnings listed in this manual, ignoring these warnings could result in serious injury to the patient or attendants.

- NEVER LIFT THE WHEELCHAIR BY THE ARMRESTS OR FRONT RIGGING.
- ALWAYS TEST THE STABILITY OF THE CHAIR BEFORE USE.
- NEVER STAND ON THE FOOTPLATES DURING TRANSFERS IN AND OUT OF THE COMMODORE.
- ENSURE WHEEL LOCKS ARE FULLY ENGAGED WHILE STOPPED ON ANY INCLINE/DECLINE AND WHILE PATIENT IS TRANSFERRING TO THE COMMODORE, OR WHILE TRANSFERING FROM THE COMMODORE.
- NEVER USE THE CASTER LOCKS TO STOP OR SLOW DOWN A MOVING WHEELCHAIR.
- IT IS NOT RECOMMENDED TO TRANSPORT USERS IN VEHICLES OF ANY KIND WHILE SEATED IN THE WHEELCHAIR. DO NOT USE ANY KIND OF WHEELCHAIR TIE-DOWN RESTRAINTS THAT ARE NOT APPROVED BY THE FDA.
- DO NOT LEAN FORWARD WHILE SITTING IN THE COMMODORE
- DO NOT LEAN OVER THE COMMODORE EDGE
- DO NOT ATTEMPT TO PICK UP OBJECTS FROM THE FLOOR
- DO NOT POSITION COMMODORE ON THE SLOP
- DO NOT IMMERS COMMODORE IN ANY LIQUID
- NOT SKILLED INDIVIDUALS MUST ASK FOR ASSISTANCE HELP DURING TRANSFER ONTO COMMODORE,
- ALWAYS LOCK ALL FOUR CASTERS IN THEIR OUTWARD POSITION BEFORE TRANFER
- DO NOT TRANFER ONTO CHAIR ON SLIPPERY SURFACES
- DO NOT STAND ON COMMODORE OR ANY PART OF COMMODORE
- COMMODORE IS NOT TRANSPORT CHAIR OR LONG TERM SEATING DEVICE
- IN CASE OF PROBLEMS  
DEALER CAN NOT RETURNED COMMODORE UNTIL ALL MAINTANANCE OR ANY PROBLEMS ARE SOLVED.

## Features

### FEATURES

- 24" – 26" Frame Wide
- 18" – Depth
- Fixed Height Full-Length Arms
- Seat to Floor Clearance Height 17 ½", 18 ½", 19 ½"
- S. to F. Clearance under Potty 13 ½", 14 ½", 15 ½"
- 5" Plastic or Stainless Steel Casing, Dual-locking Casters
- 70 or 60 Degree Swing-away Front Rigging with Footplate
- Choice of 2 colors ( White or Electro polished natural Stainless Steel )
- Back Support: Foam skinned rectangular shaped back easy to remove and clean.

### SPECIFICATIONS

- User Weight Limit 600 lb.
- Chair Width: 24" or 26".
- Seat Depth 18".
- Chair Length no Footrest: 27 ½".
- Chair Length with Footrest 38".
- Chair Height: 38" to 41".
- Chair Weight: 50 Lbs.  
(Without front riggings).

**Safety Inspection Checklist**

Initial adjustments should be made to suit your personal body structure needs and preference. Thereafter follow these maintenance procedures:

Item	Initially	Weekly	Monthly	Periodically
<u>GENERAL</u> Wheelchair rolls straight (no excessive drag or pull to one side)	X		X	
<u>FRAME AND CROSSING TUBES</u> Inspect for loose or missing hardware Inspect for bent frame or cross-tubes	X X			X X
<u>CASTER LOCKS</u> Caster locks easy to engage Caster locks prevent chair from moving when engaged	X X		X	X
<u>SEAT AND BACK</u> Inspect for rips or sagging Inspect for loose or broken hardware Inspect cane for wear/looseness	X X X		X X	X

<u>FRONT CASTERS/FORKS</u>				
Inspect caster fork assembly for proper tension by spinning caster; caster should come to a gradual stop	X	X		
Adjust bearing system if wheel wobbles or binds to a stop. Ensure wheel bearings are clean and free of moisture.	X		X	X
Check stem caster journal and lock nut for tightness	X		X	
Inspect casters for cracks and wear	X			X
<u>CLEANING</u>				
Clean seat backrest and armrests	X			X

**Troubleshooting**

Chair Veers Right/Left	Sluggish Turn or Performance	Caster Flutter	Squeaks and Rattles	Looseness in Chair	Solutions
	X	X	X	X	Check for loose nuts and bolts
X		X			Check a caster assembly



## 2 Arms

<b>WARNING</b>
----------------

After **ANY** adjustments, repair or service and **BEFORE** use, make sure all attaching hardware is tightened securely – otherwise injury or damage may occur.

### **ROTATING ARM ASSEMBLY UPWARDS/DOWNWARDS**

1. Grasp the top portion of the arm assembly and rotate the arm upwards to the position shown in the figure in lower right corner. One should notice the arm outer tube sliding along the arm inner tube in order to achieve a large rotation angle and help to support the armrest while it is resting vertically.
2. At this point the arm assembly should come to a stop. The occupant can be transferred to another device such as a wheelchair or bed.
3. In order to bring the arm assembly down to the horizontal position grasp the top portion of the arm assembly and rotate the arm downwards to the position shown in the lower left corner until the arm comes to a stop.

ARM ASSEMBLY

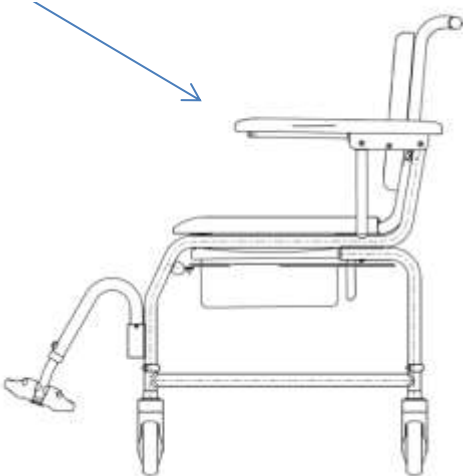

ARM ASSEMBLY IN HORIZONTAL POSITION

ARM ASSEMBLY

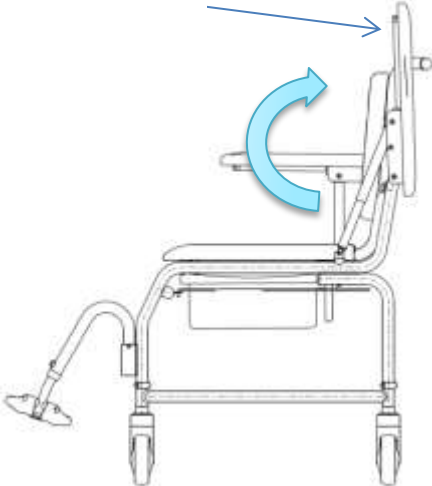

ARM ASSEMBLY IN VERTICAL POSITION

### 3 Back

#### WARNING

After **ANY** adjustments, repair or service and **BEFORE** use, make sure all attaching hardware is tightened securely – otherwise injury or damage may occur.

#### REPLACING THE BACK SUPPORT

1. Remove the six (6) 1/4-20 x 1/2" screws from the back frame which holds the foam skinned backrest in place.
2. Fasten the new foam skinned backrest with six (6) 1/4-20 x 1/2" screws.

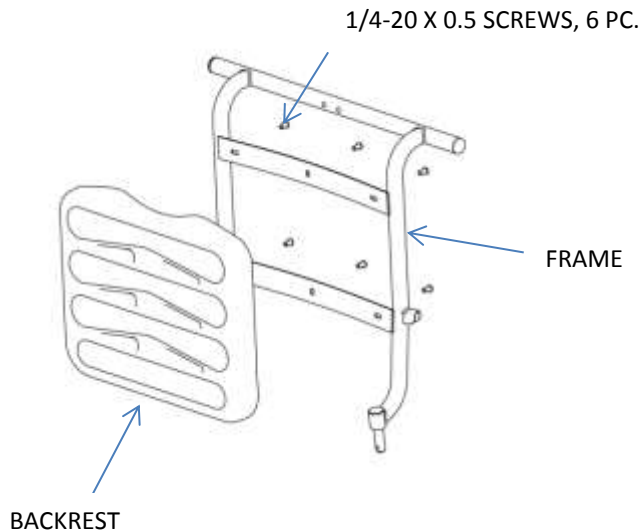

## Lifting the Back frame

### LIFTING THE BACK FRAME FOR DETAILED CLEANING OR MAINTANANCE

1. Remove the two (2) safety snap clips by pulling back from the back
2. Lift the frame up

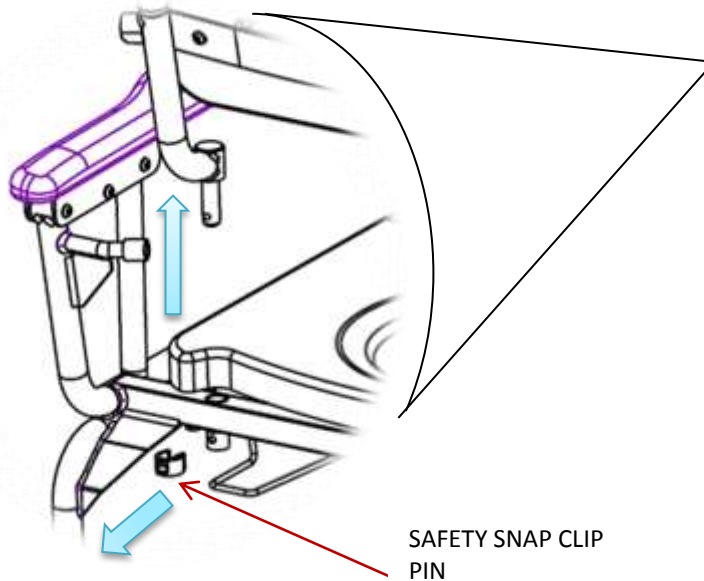

### Reinserting the Back frame

REINSERTING THE BACK FRAME AFTER DETAILED CLEANING OR MAINTANANCE

1. Reinsert the frame
2. Reinsert two (2) Safety snap clips

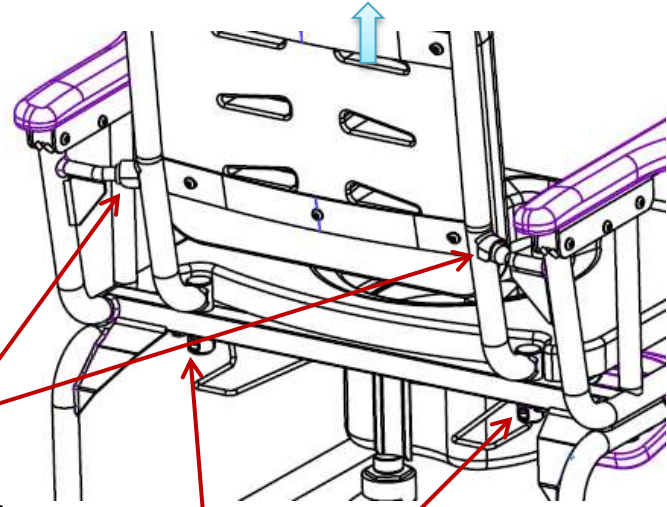
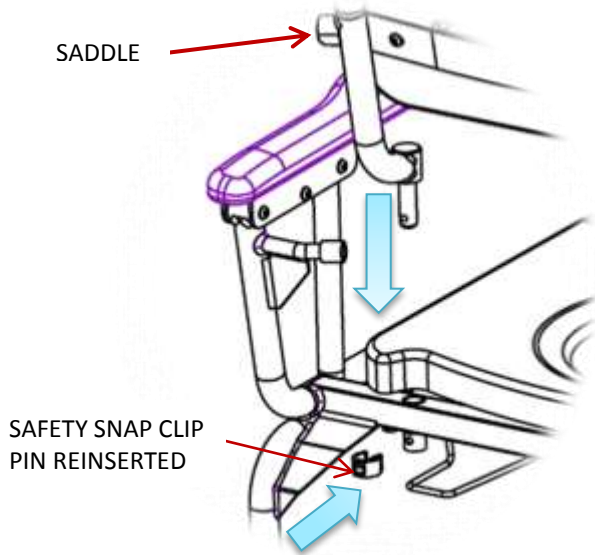

SADDLES ON BOTH SIDES HAS TO FULLY SEAT ON THE SADDLE PINS ON THE MAIN BASE FRAM

SAFETY SNAP CLIPS HAS TO BE FULLY INSERTED ON BOTH SIDES

## 4 Casters

### Adjusting Casters high and engaging

1. Remove the snap clip (A) by pulling back from the frame
2. Set the desired position of the caster (B).
3. Insert back snap clip into hole (C)
4. Do same for all other casters

**DO NOT ATTEMPT TO USE CASTERS POSITIONS FOR ADJUSTING FRAME ANGLE**

#### Castors engaging

For engaging the dual lock, step on the end until it latches in the ON position

For disengage step on the raised end until caster lock latches in the OFF position

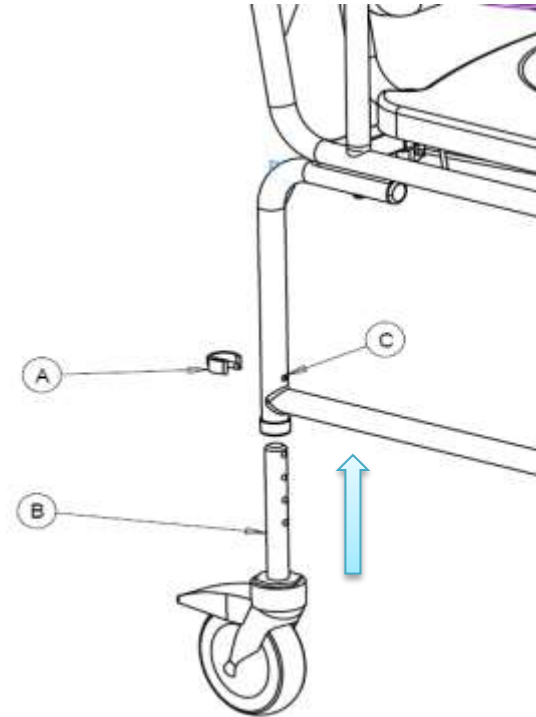

## 5 Seat Installation

### TO INSTALL THE SEAT

1. Slide the rear of the seat over the rear square cross tube as the front of the seat is lowered onto the frame  
Rear brackets has to hook on square tube
2. Lower the front of the seat until the front seat brackets snap and nestle onto the front support cross tubes.
3. Check to make sure that all brackets are engaged

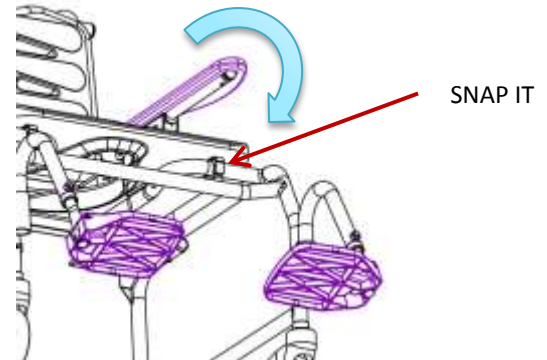
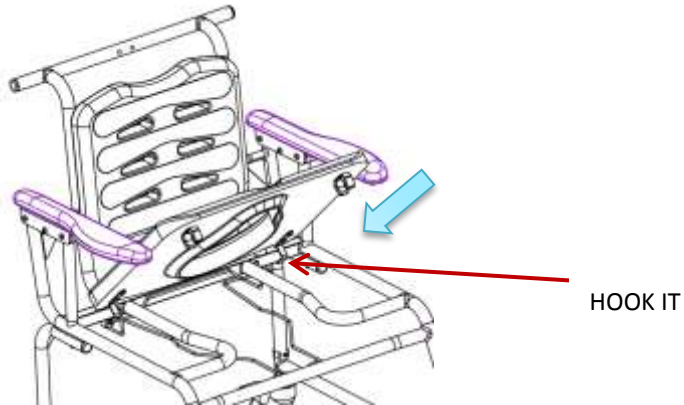

**Installing the Potty**

1. Removal of the Potty is achieved by sliding the Commode outside from back
2. Reinserting Potty is achieved by pushing inside into wire slider until is fully positioned and engaged

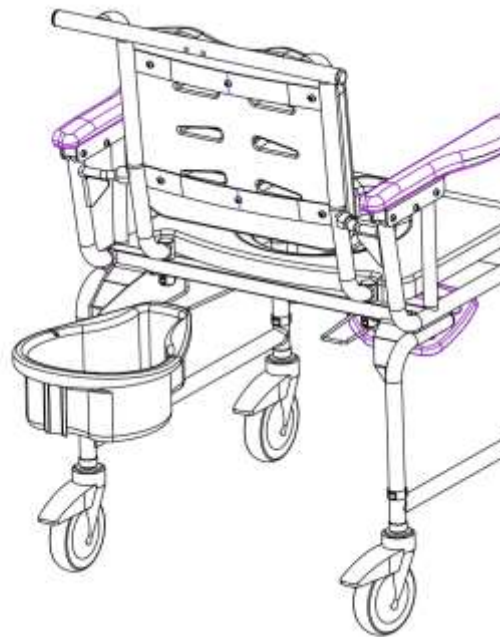



## 6 Footrest

1. Remove the front rigging assembly.
2. Loosen the 1/4-20 x 1/2" socket head button screw which fastens the footrest hanger to the footrest stem. Slide the footrest stem up or down to desired height. There should be approximately 2-3/8" of range for the footrest extension.
3. Re-tighten socket head button screw.
4. Repeat this procedure with the other footplate assembly.

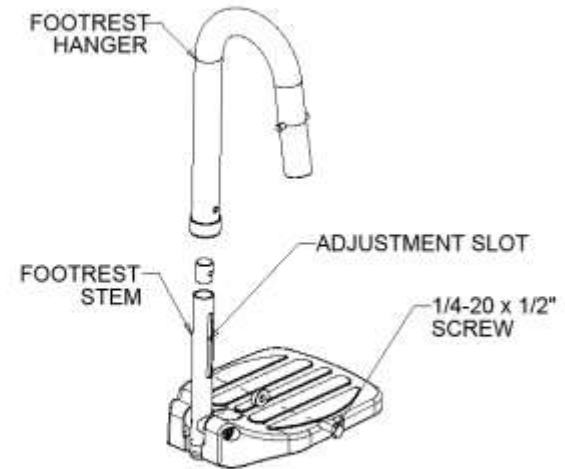

## 7 Cleaning and maintenance

### *Procedure for Cleaning After Each Use*

#### *Commode Potty*

- Remove the Commode Potty and empty its contents.
- Wash the potty with a multi-purpose disinfectant detergent.
- **DO NOT USE HOT AIR FOR DRYING.**

#### *Urethane Seat and Back*

- Use a multipurpose disinfecting detergent to spray seat, scrub with soft brush to clean a dirt.
- Rinse well and dry by wiping with soft dry cloth.
- **DO NOT USE HOT AIR FOR DRYING.**
- For more detailed cleaning, remove the seat from commode chair.
- **DO NOT IMMERS**E the commode chair seat in water or cleaning detergent solution.

### *Procedure for Cleaning As Needed*

#### *Frame, Armrest, Footrests and Other Components*

- Spray the frame and components with multi-purpose disinfectant detergent, and scrub with soft brush.
- Rinse well and dry by wiping with soft dry cloth.
- **DO NOT USE HOT AIR FOR DRYING.**
- If needed, spray the frame and components with diluted (10 parts water to 1 part solution) calcium/lime removal solution, scrub with soft brush and rinse well with water, dry with soft dry cloth.

- **DO NOT** mix a calcium/lime remover with any other liquid or toxic fumes may result.

It is recommended that the rinsing of Aqua Commodes components occur in a well-drained area with an industrial steam cleaner or a commercial pressure washer.

Several times during year the chair and all components should be wiped down with a diluted calcium/lime removal solution.

By wiping down with soft clothes after final rinse risk of mildew buildup will be minimized.

***IMPORTANT:***

***DO NOT USE ABRASIVE POWDERS OR SCOURING PADS ON AQUA COMMUNE***

***DO NOT SUBMERGE COMMUNE IN WATER***

***RINSE AFTER CLEANING TO ENSURE THAT ANY SOAP OR DETERGENT RESIDUE IS REMOVED***

***DO NOT USE CLEANING PRODUCTS WITHOUT CONSULTING THE PRODUCTS' INSTRUCTIONS AND TAKING APPROPRIATE PRECAUTIONS FOR HUMAN EXPOSURE TO CHEMICALS***

## 8 Warranty

Future Mobility Healthcare Inc. ("FMH") warrants its Aqua Rehab Commode NT600 Wheelchair to be free from defects in materials and workmanship for one (1) year from the date of purchase. The frame is warranted for (2) years of the original purchaser/user. If within this warranty period the product shall be proven to be defective, such product shall be repaired or replaced, at FMH discretion. FMH's sole obligation and your exclusive remedy under this warranty shall be limited to the repair and/or replacement of the product or its parts. This warranty does not include any labour or shipping charges incurred in replacement part installation or repair of any product.

For warranty service, please contact the dealer from whom you purchased your FMH product. In the event you do not receive satisfactory warranty service, please write directly to FMH. Provide the dealer's name, address, model number, date of purchase and indicate the nature of the defect.

DO NOT return products to FMH without our prior consent. The defective unit or parts must be returned for warranty inspection within thirty (30) days of the return authorization date. (FMH will issue a return authorization number). Please prepay all shipping charges; C.O.D. shipments will be refused.

LIMITATIONS and EXCLUSIONS: This warranty shall not apply to problems arising from normal wear or failure to adhere to the enclosed instructions. Products subjected to negligence, accident, improper usage, maintenance or storage; or products modified without FMH written consent including, but not limited to: modification through the use of any unauthorized parts or attachments; products damaged by reason or repairs made to any component without the specific consent of FMH, or products repaired by anyone other than a FMH dealer. Such evaluation shall be determined by FMH.

The foregoing warranty is exclusive and in lieu of all other expressed warranties. It shall not extend beyond the duration of the expressed warranty provided herein and the remedy for violations of any implied warranty shall be limited to repair or replacement of the defective product pursuant to the terms contained herein. FMH shall not be liable for any consequential or incidental damages whatsoever.

This warranty shall be extended to comply with all state laws and requirements.

Cut below this line

*Warranty Registration Form*

To validate your Future Mobility HealthCare warranty, please complete the below form and return it the address at the end of this form. Visit online at [www.futuremobility.ca](http://www.futuremobility.ca) for more Future Mobility Products.

Name: \_\_\_\_\_  
Street Address: \_\_\_\_\_  
City/Country/Postal Code: \_\_\_\_\_  
Telephone: \_\_\_\_\_  
Purchased Date: \_\_\_\_\_  
Purchased From (Dealer Name and Address): \_\_\_\_\_  
Product Purchased: \_\_\_\_\_  
Serial Number: \_\_\_\_\_

**Print and Mail it to:**  
**Future Mobility Healthcare Products**  
**3223 Orlando Drive**  
**Mississauga, Ontario, L4V 1C5**  
**Fax: 905-671-3377**







**USA**  
Future Mobility Products US LLC  
1 Buffalo River Place  
Buffalo, NY, 14210  
Ph: 716-783-9130 - 1 855-938-8873  
Fax: 716-783-9236  
e-mail: [customerservice@futuremobility.com](mailto:customerservice@futuremobility.com)  
[www.futuremobility.com](http://www.futuremobility.com)



**CANADA**  
Future Mobility Healthcare Inc.  
3223 Orlando Drive  
Mississauga, ON, L4V 1C5  
Ph: 905-671-1661 - 1 888 737 - 4011  
Fax: 905-671-3377  
e-mail: [customerservice@futuremobility.ca](mailto:customerservice@futuremobility.ca)  
[www.futuremobility.ca](http://www.futuremobility.ca)