

INSTALLATION MANUAL CENTERBELT NEST WITH MOVEABLE REAR WALLS

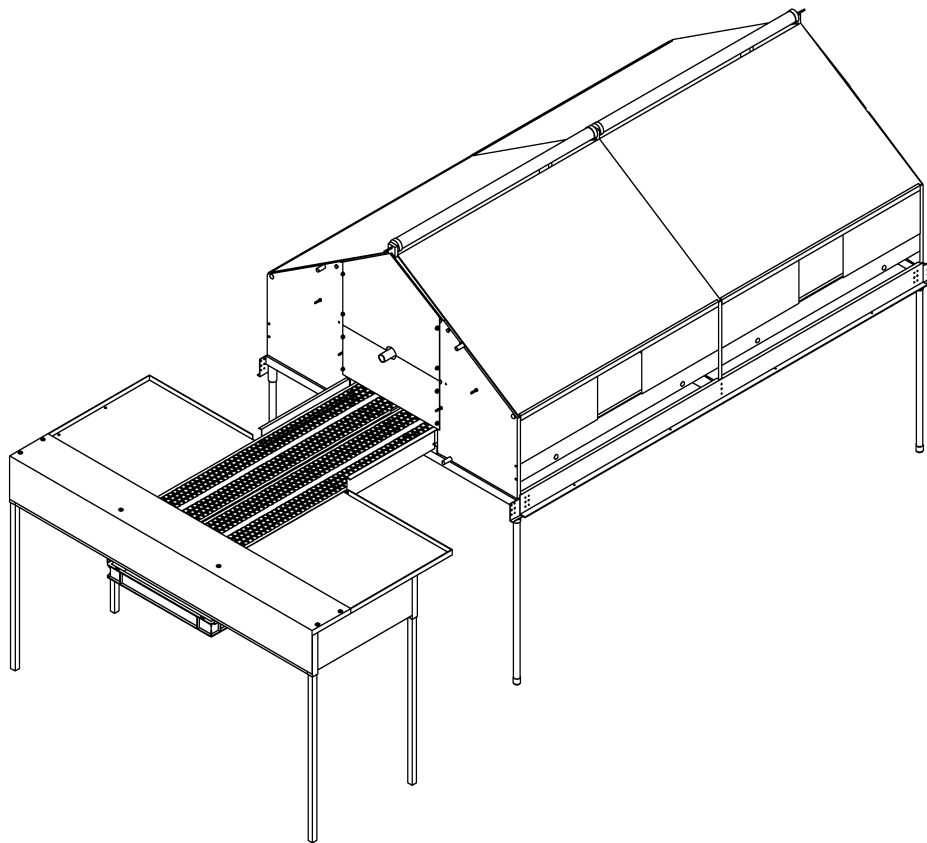

Please read and understand this manual before unpacking and beginning assembly.

Tip: A 10 mm socket has been provided to assemble all M6 bolts and nuts.
A 7 mm drill bit has been to clean bolt holes when necessary.

Insert the legs into the undercarriages and secure with hex bolts M8x20 (631015).

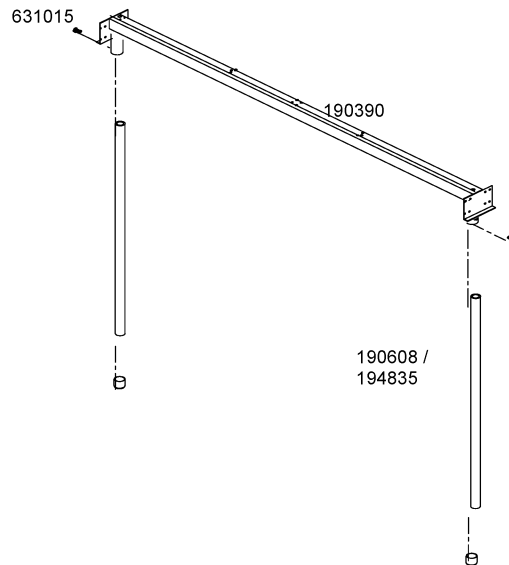

Fix the side plates (190566) to the undercarriages with 8 blind rivets 5x12 (171243) per side.

Attention: Check (especially in the beginning) if you set the undercarriages up square (measure the distances between the legs crossways: these should be equal).

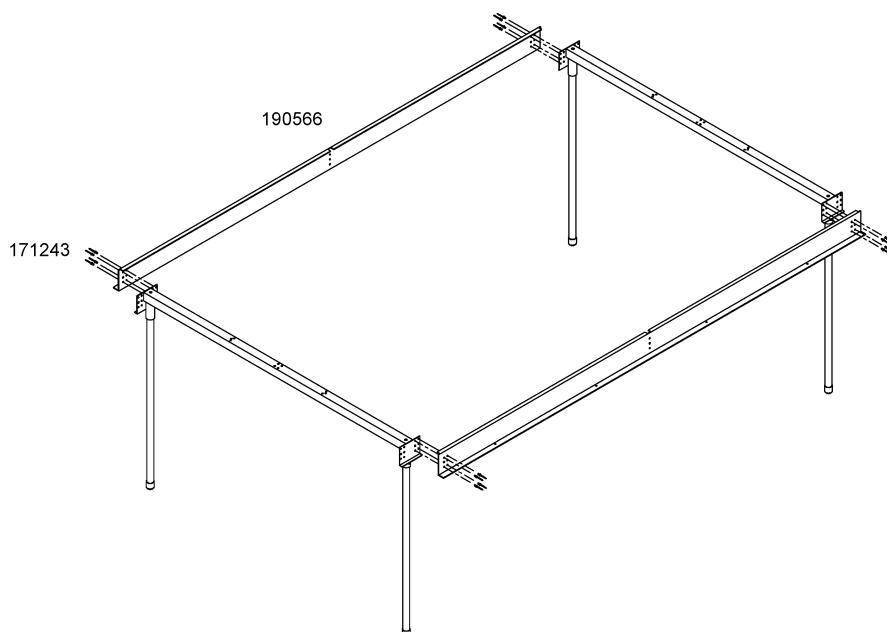

Fix the partition undercarriages (190391) between the side plates with blind rivets 5x12. Make sure the undercarriages are standing square, lined up in a straight line, and check them with a water level. Once undercarriages are level and straight, drive self tapping safety screws 190488 in all legs; use one of the holes alongside the M8x20 bolt in the undercarriage.

Attention: Make sure the flat side of the partition undercarriage faces the front of the house, otherwise the sharp side of the partition undercarriage can wear through the conveyor belt.

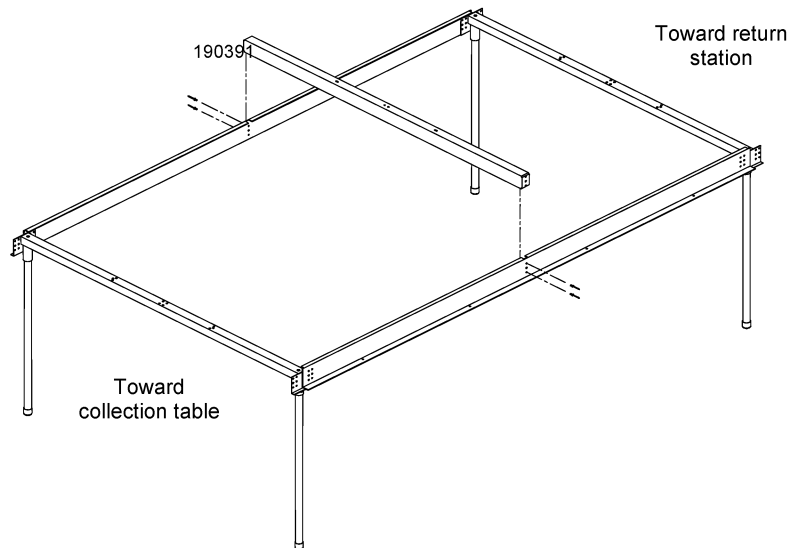

Fix the belt guide (130550) to the undercarriages with blind rivets 5x8 mm (171242).

Attention: The recesses in the belt guides should face the front of the house (see picture).

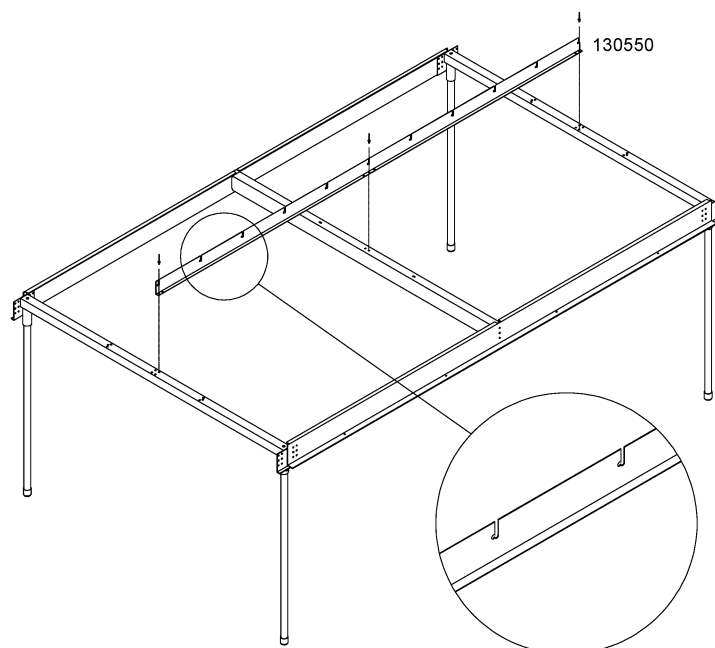

Fix the hooks (130397) to the return station (137203 or 137204) with 2 blind rivets 5x8.

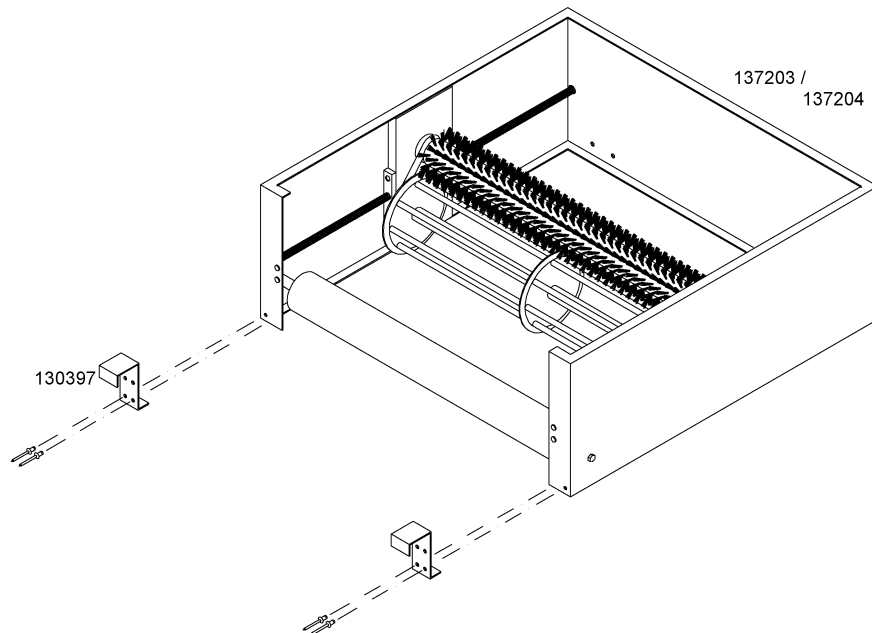

Hook the return station to the last undercarriage.

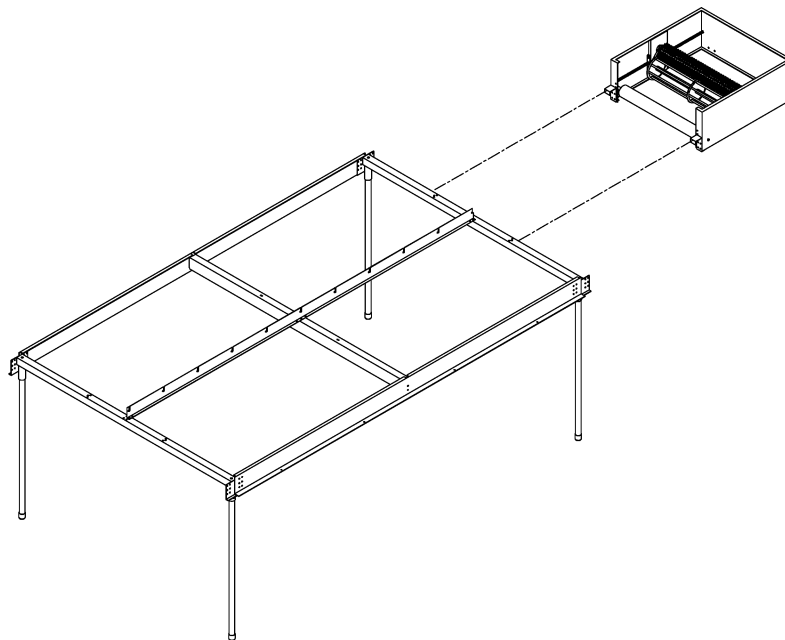

Assemble the return station: place the studs M16 (231001) with the hex nuts M16 (231002) in the T-barred legs (195013). Screw the leg supports (134169) to the return station with hex bolts M6x16 (231105) and hex nuts M6. Fix the T-barred legs to the leg supports with hex nuts M16.

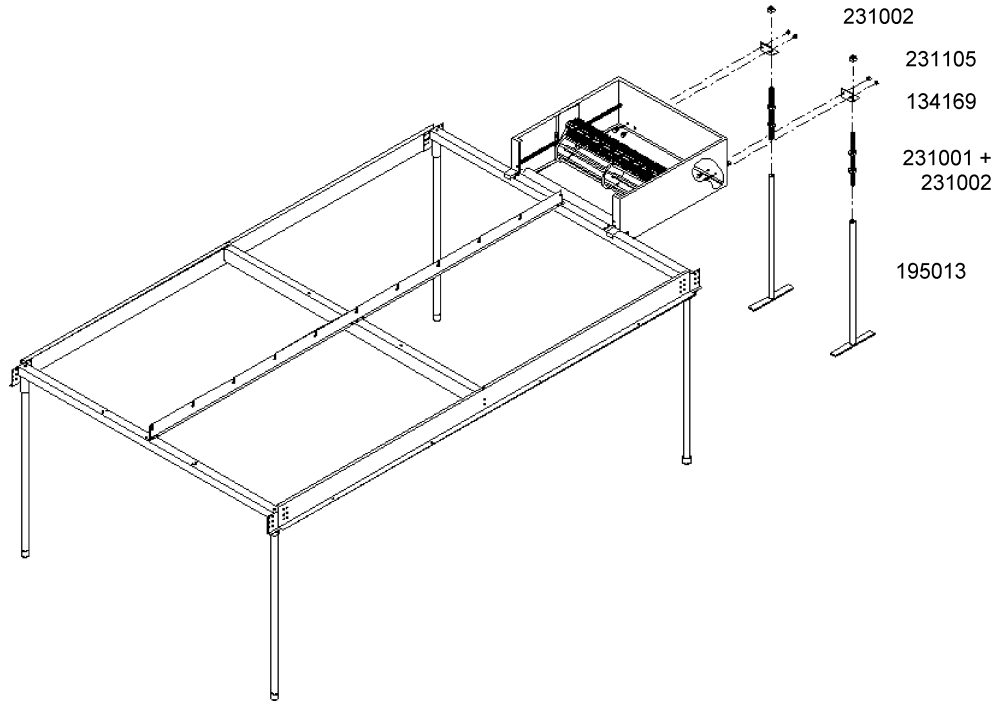

Pull the conveyor belts (134032 164817) from the front of the house over the undercarriages to the return station.

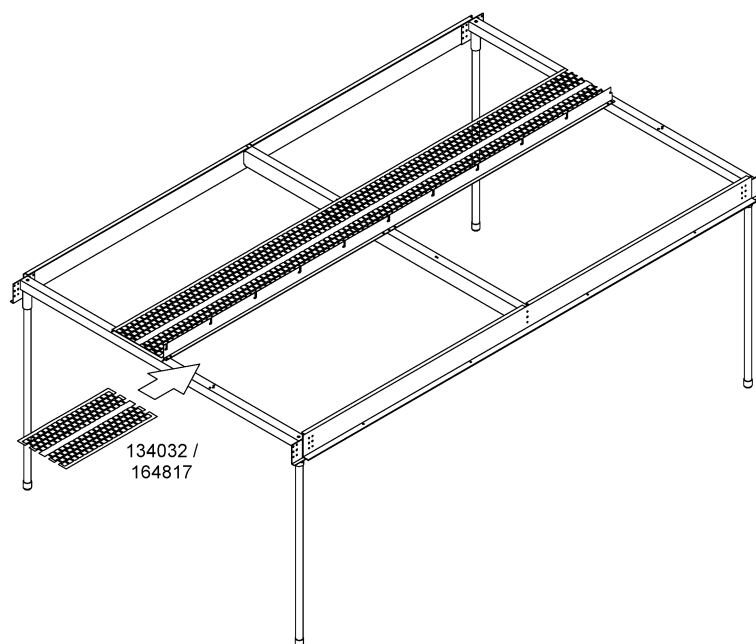

Lay the wire gauze panels (130401) on the belt guides and over the conveyor belts.
Attention: The crossbars of the wire gauze panels should face up.
Pull the wire gauze panels to the front of the house, so that the crossbars hook into the belt guides.

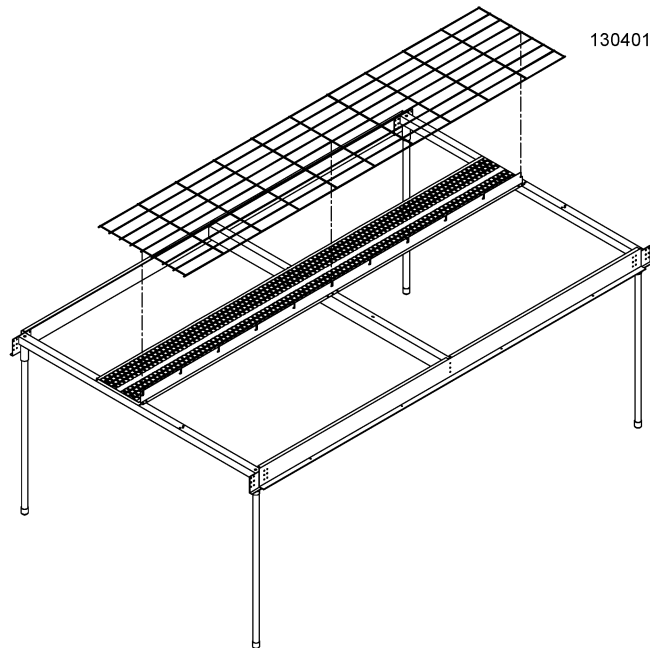

Press the egg bump profile (130495) on the belt guides.

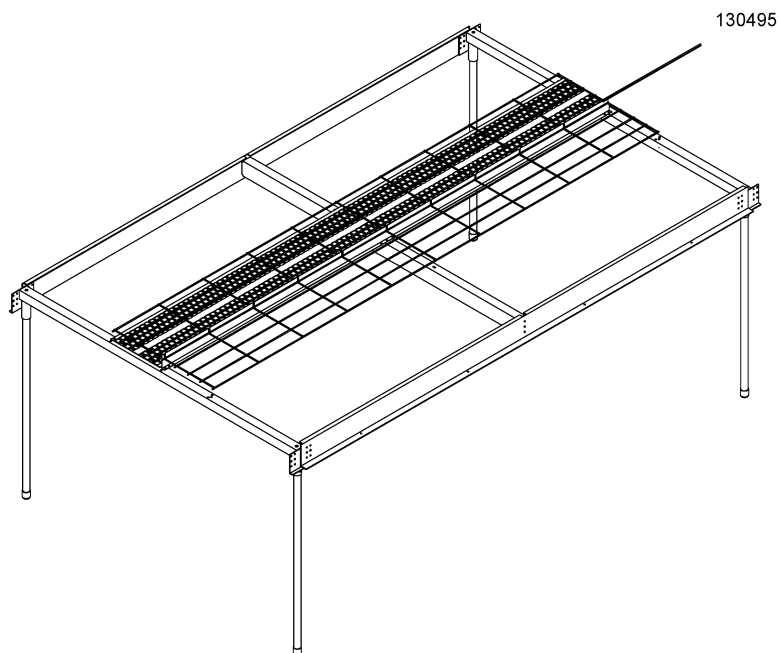

Pull the conveyor belts through the return station over the wire gauze panels to the front of the house.

Attention: Guide the conveyor belts in the return station between the return belt roller and the stud M8 (see Appendix C for egg belt route).

The belts will be welded or glued later.

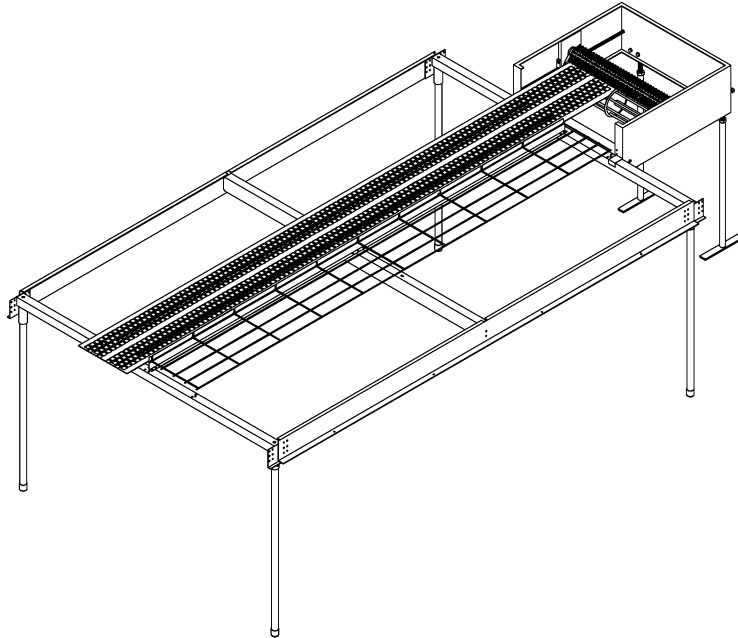

Screw the wire gauze panel supports (130552) with a chipboard screw 4 mm diameter x 30 mm long (161099) to the partition walls (133354).

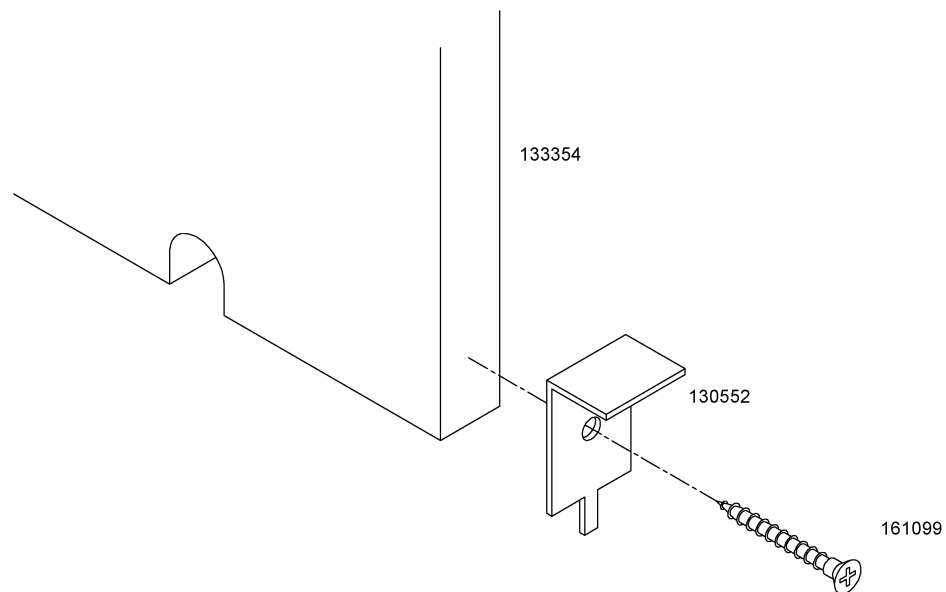

Fix the floor supports (130551) with carriage bolts M6x30 (161100), washers (311199) and hex nuts M6 onto the jump beams (133294).

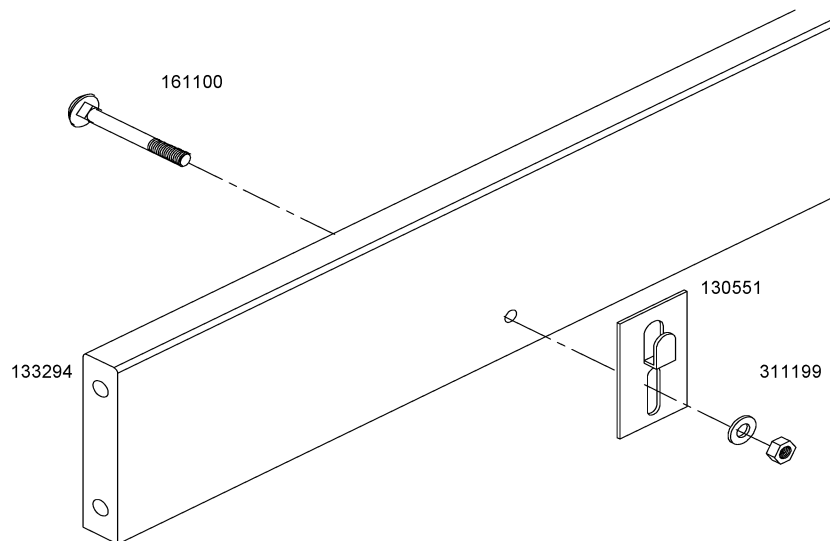

The following 2 steps should be carried out simultaneously:

1. Lay the 16mm diameter tube (136218) for the floor support on the undercarriages and place the partition walls over the tubes on the undercarriages. Connect the tubes with PVC sleeves 5/8" (136219). Make sure that the gauze mat support bracket (130552) support the wire gauze panel (130401).
In case of a walkover, only place the outer partition walls of the entire walkover (walkover is 2.3m wide).

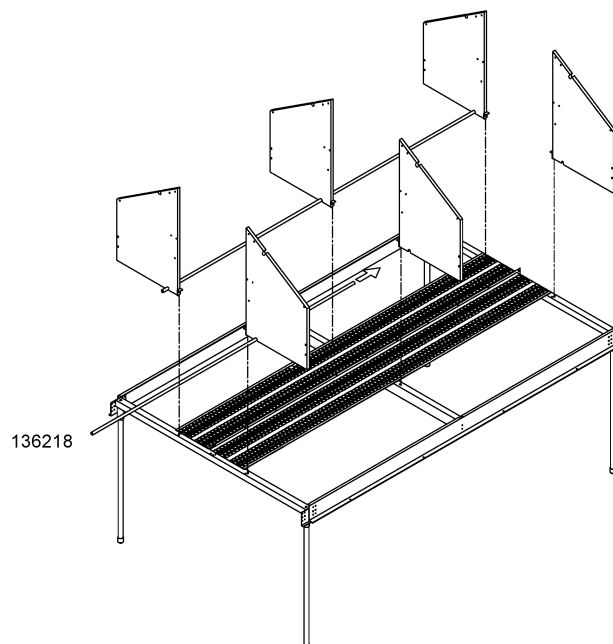

2. Fix the jump beams between the partition walls with dowels 8 mm diameter x 80 mm long (133296).

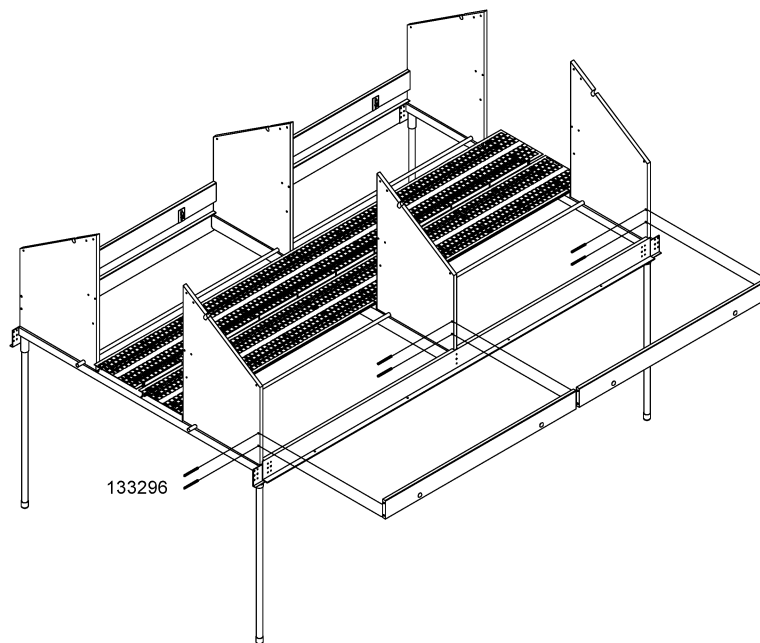

Press the bronze plain bearings (136669 or 136215) into the bearing plates (130388).

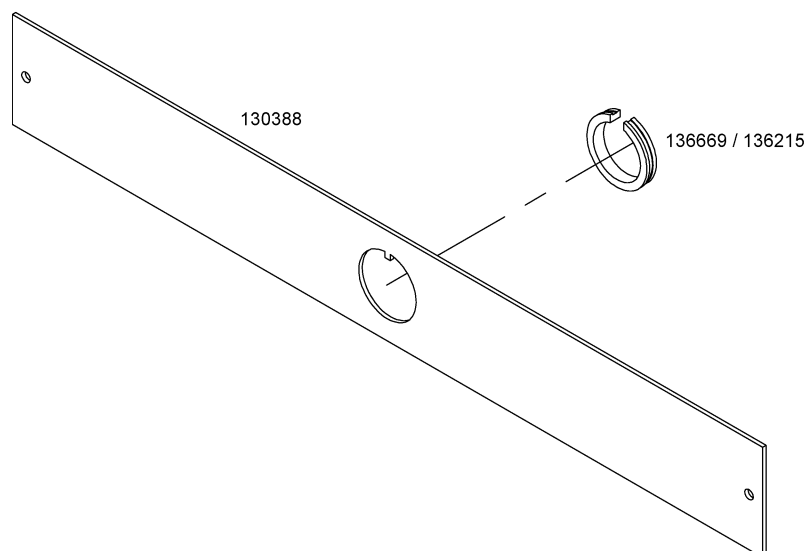

Fix one bearing plate per section to the partition walls with carriage bolts M6x30 and hex nuts M6. Make sure that there is a bearing plate at the beginning and at the end of the row of nests. Do not fix a bearing plate in the middle of the row where the flapmotor support will be placed.

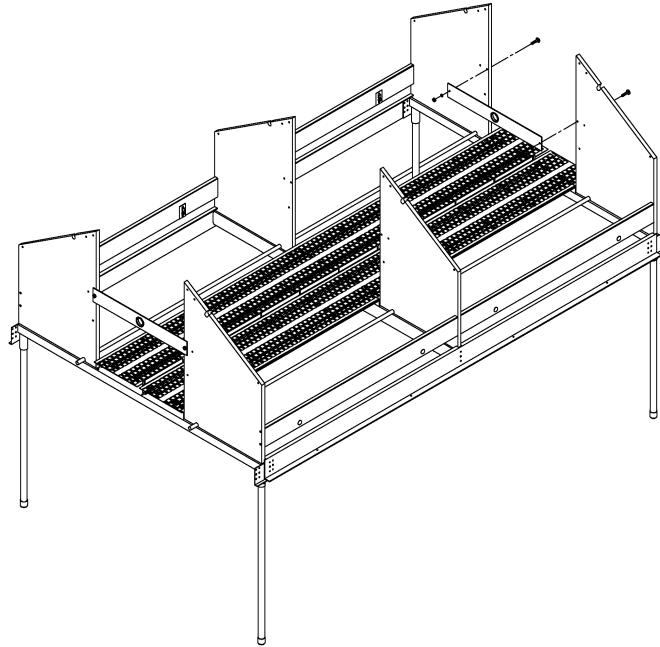

Fix the flapmotor support (130419) in the middle of the row between two partition walls with 8 carriage bolts M8x30 and hex nuts M8.

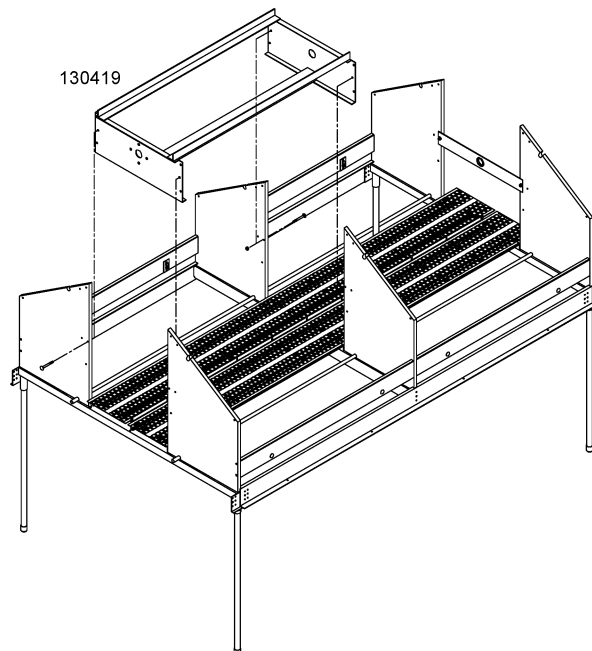

Screw the gearbox (137161) and the motor (900346) to the motor support with 4 hex bolts M10x20 (151070). First remove the sprocket on the side of the fixation points of the flapmotor, so that the shaft can be placed through the motor support. Place the sprocket back on the motor after hanging the motor.

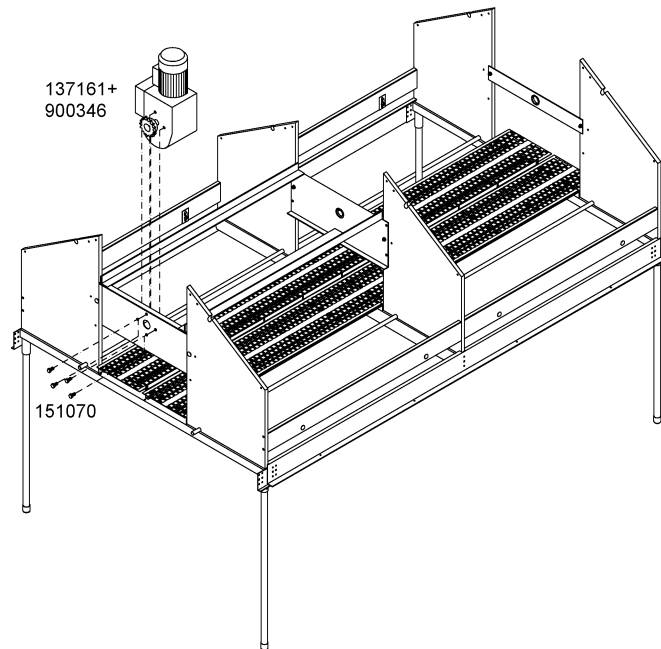

Hook the rack springs (816728) on the plastic slide brackets (130745)

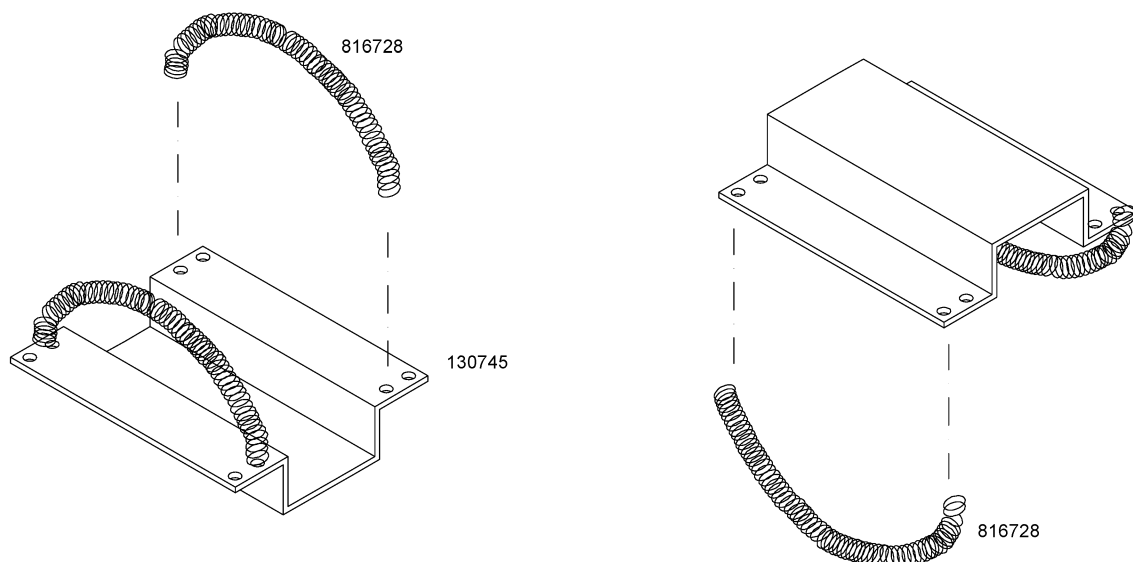

Push the extension shafts (136213) through the bearing plates and the flap motor support. Don't forget to slide the pinions (136652) onto the extension shafts

Attention: there should be a pinion on the extension shafts between every pair of partition plates (except for a walkover).

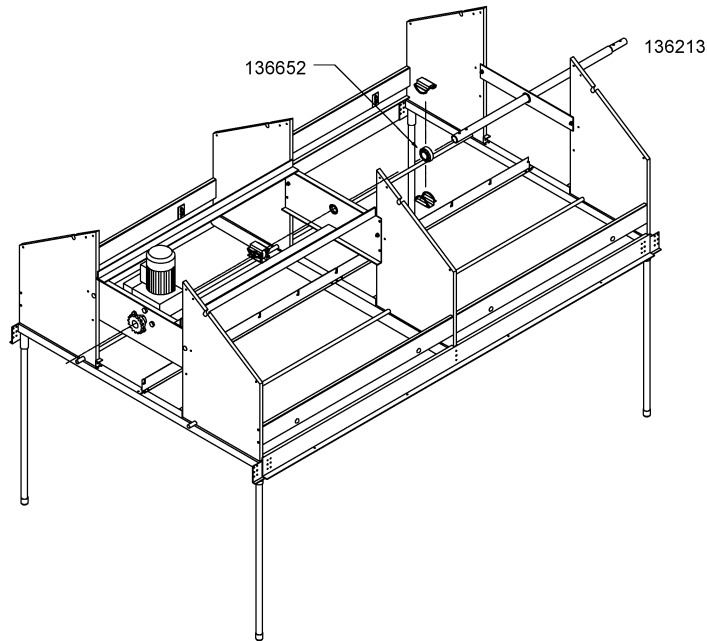

Screw the sprocket tube connections (130006) to the extension shafts where a flapmotor is placed, with 2 hex bolts M8x50 (131106) and 2 lock nuts M8 (631009).

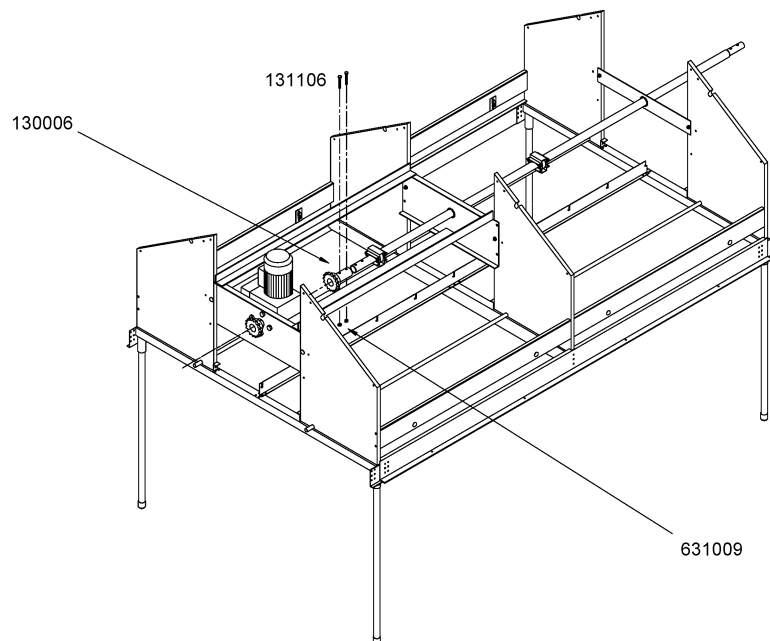

Connect the sprocket tube connections to the flapmotors with the double chains 5/8" (136129) and the double chain closing links (136130).

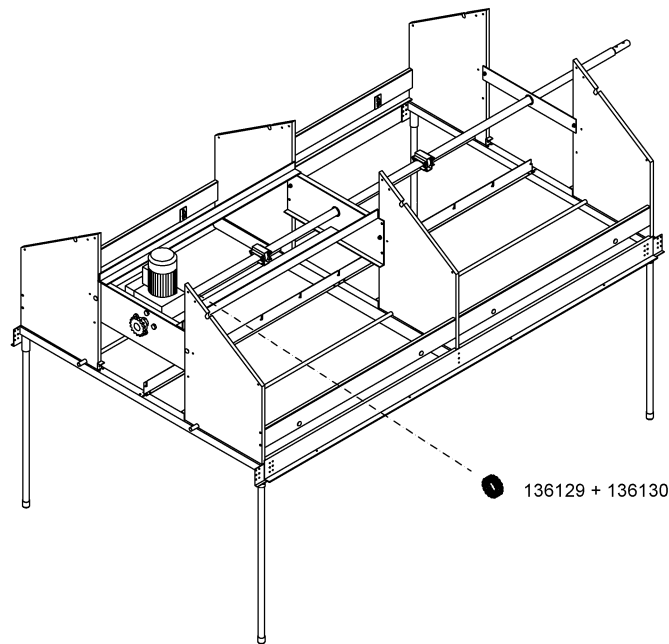

Hook the rubber mats (134030 or 134033) onto the plastic floors (130493).

Lay the plastic floors at the front in the floor support brackets, and let the back of the plastic floors rest on the 16mm diameter tube. Make sure that the lip of the plastic floors are under the wire gauze panels.

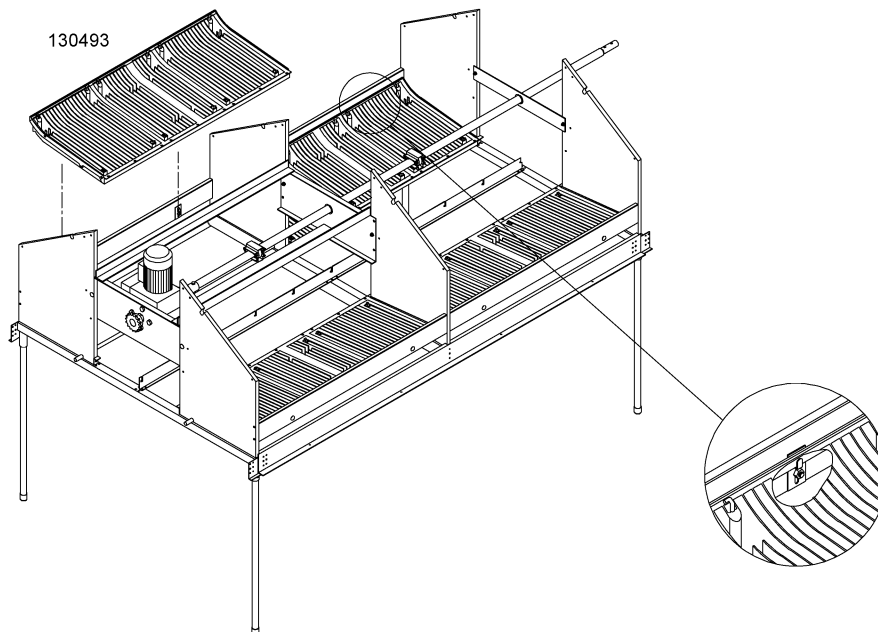

Screw the rear stops together: 1 stud M6x80 (131460), 2 washers M6 (311199) and 2 hex nuts M6.

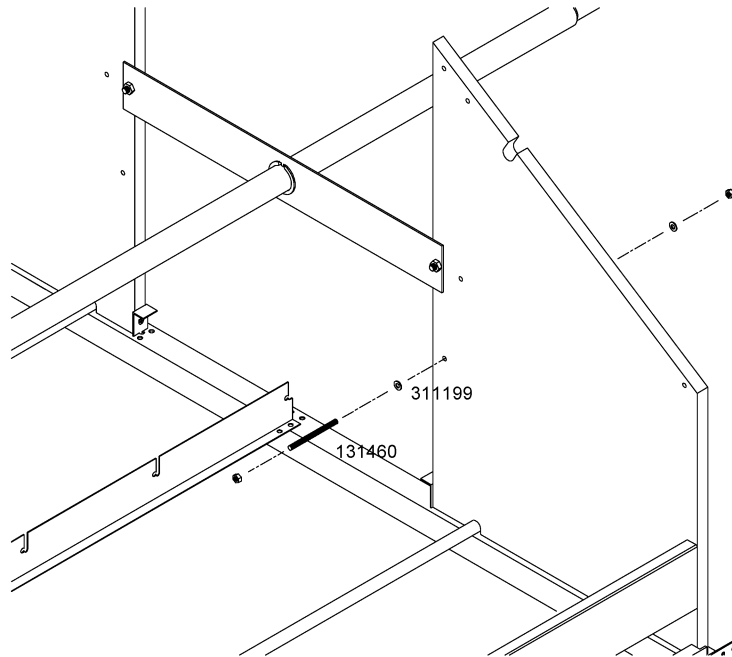

Screw the hinges (130386) to the wooden back wall (133355/133362) with carriage bolts M6x30 (161100) and hex nuts M6. Screw the frame brackets (136209) to the drive-out plates with carriage bolts M6x30 and hex nuts M6. Do **not** cut the gray curtain.

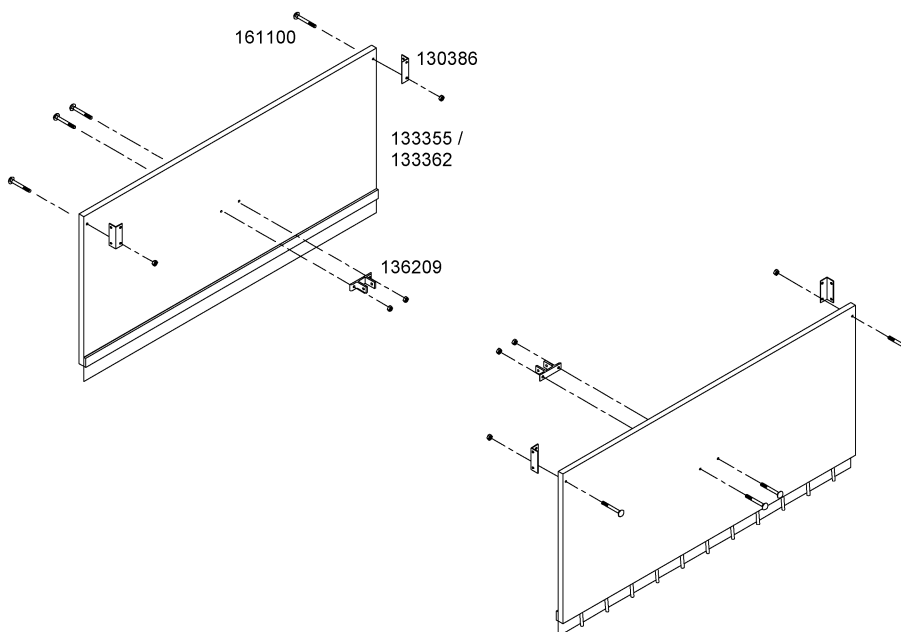

Screw on one side the racks (130549) with the teeth pointing down to the frame brackets with hex bolts M6x50 and hex lock nuts M6. Push the racks between the pinions and the upper sliding brackets.

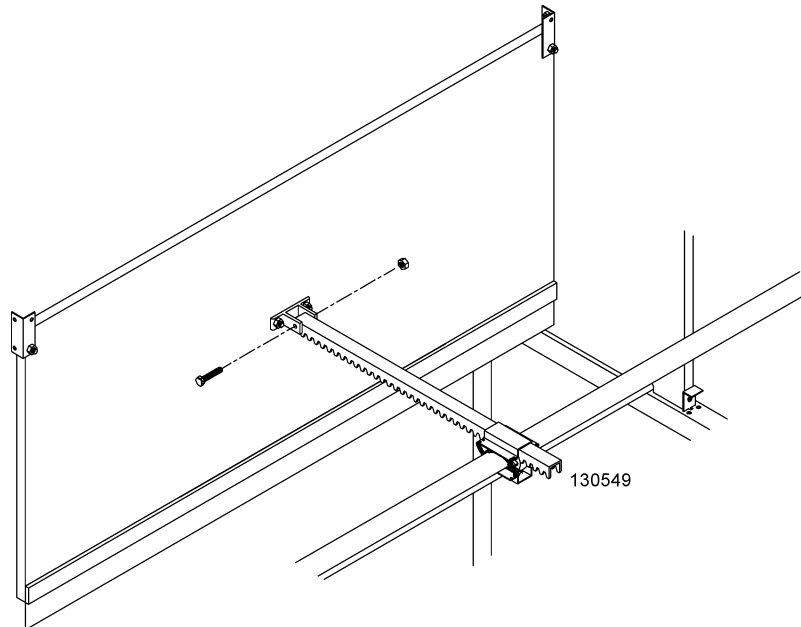

Place the wooden back wall with the rack in the fully open position. Screw the hinges of the drive-out plates to the partition walls with 2 hex bolts M6x35 (641084) and hex lock nuts M6.

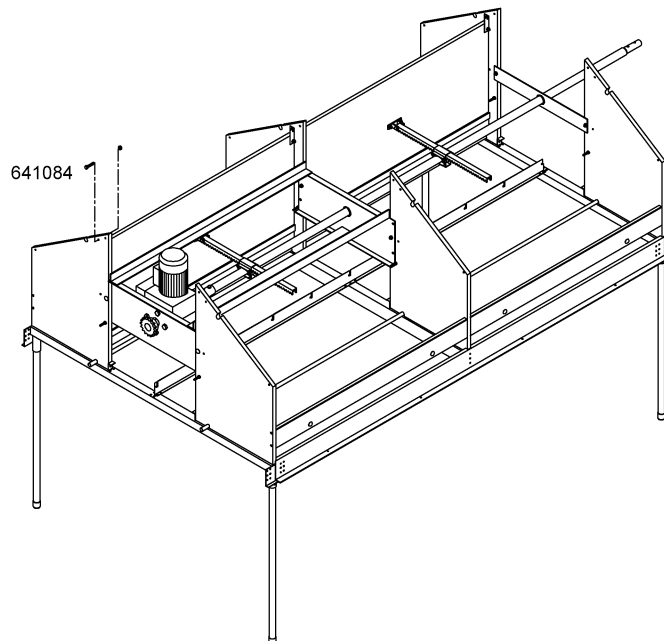

Turn the pinions with the set screws towards you by lifting the racks and turning the pinions. Be sure to align the pinion with the gear rack. Tighten the set screws in the pinions **very well!**

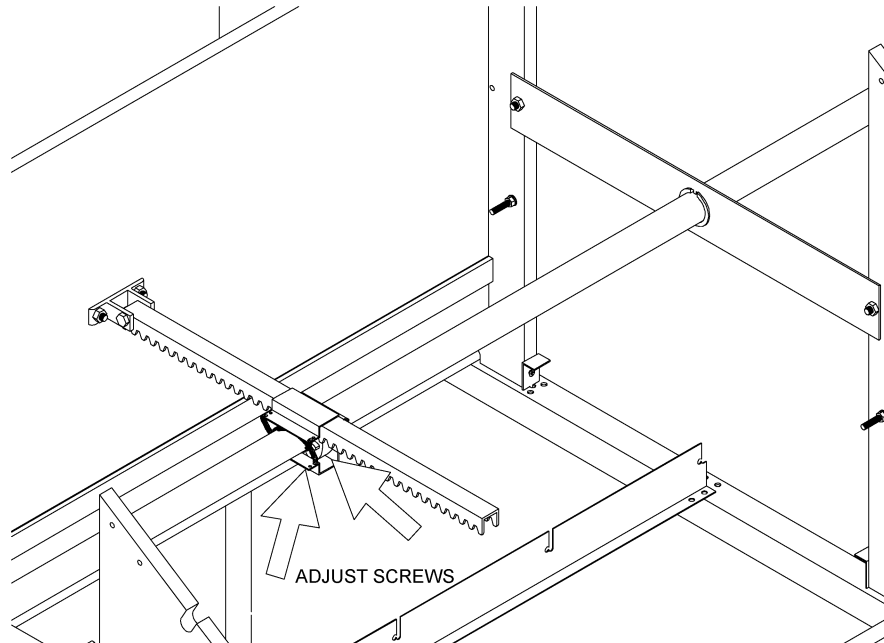

Fix the other racks to the remaining drive-out plates *with the teeth pointing up*. Place the drive-out plate in the right position. Push the racks between the pinions and the lower sliding brackets. Fix the hinges of the drive-out plates to the partition plates with 2 hex bolts M6x35 and hex lock nuts M6.

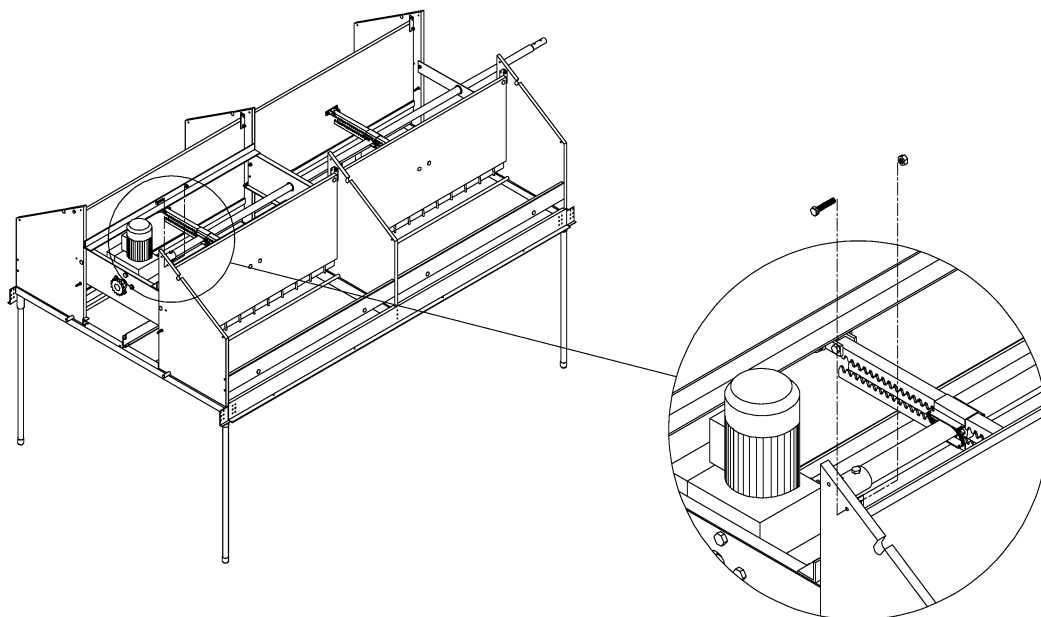

Screw the front stops together: 1 stud M6x80, 2 washers M6 and 2 hex bolts M6.

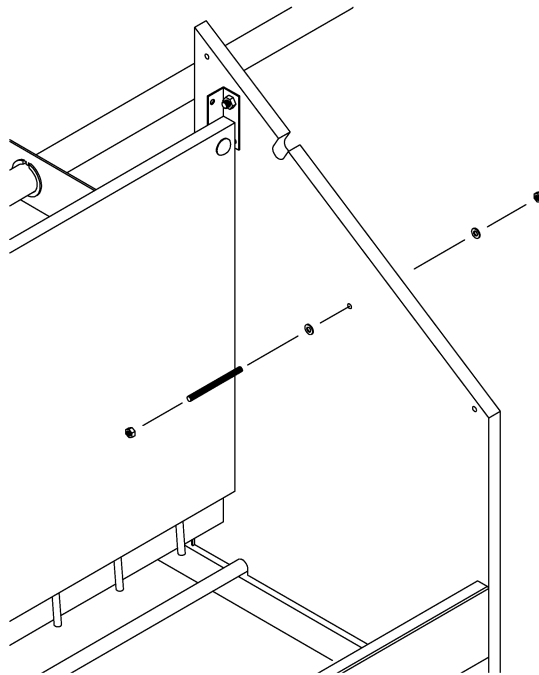

Press the spindles of the roller tubes (134043) through the ridge points (134390). Screw the ridge points on the trusses (130395) with chipboard screws 4 mm diameter x 30 mm long (161099).

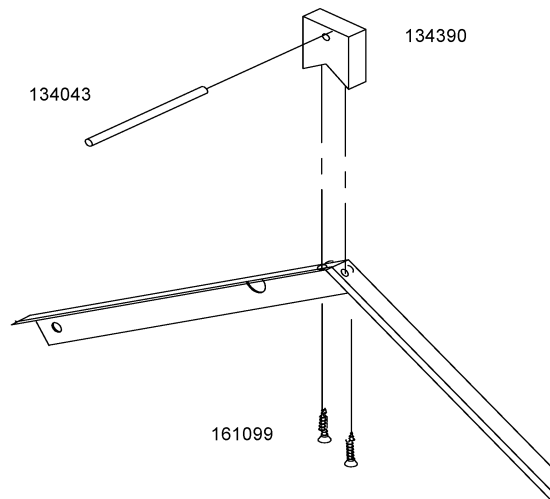

Press the covers for the roller tubes (134027) on the roller tubes (134031).

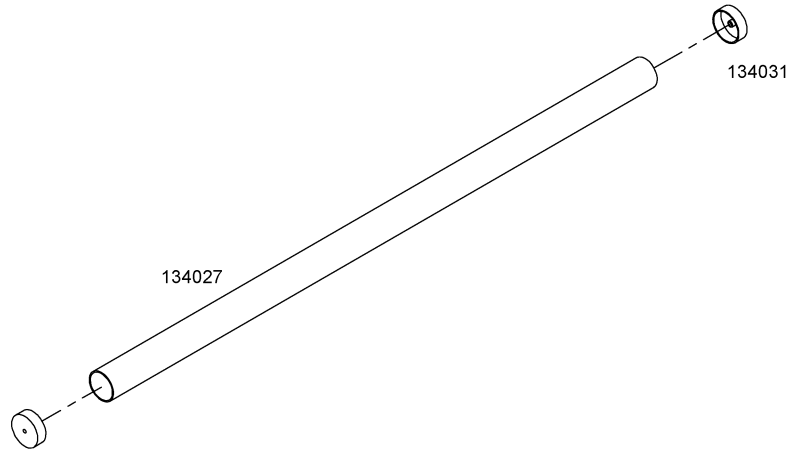

Fix the trusses on the partition walls with carriage bolts M6x30 and hex nuts M6.

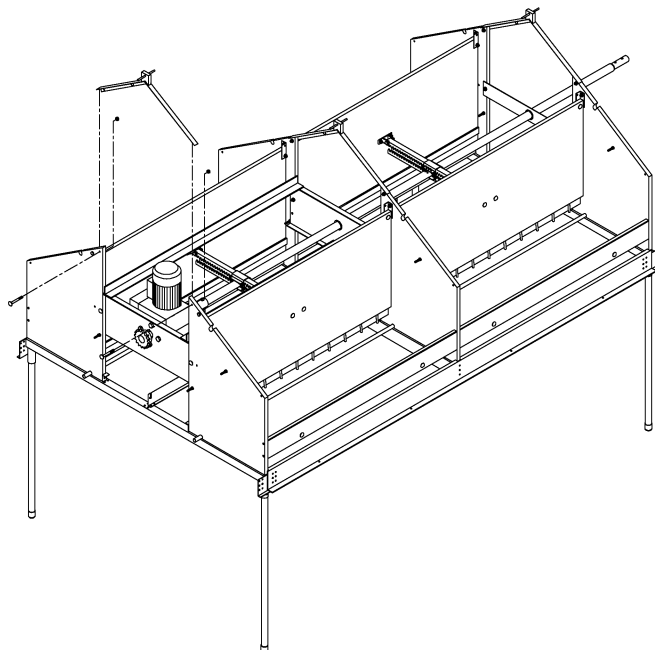

Fix the roller tubes with the covers on the spindles for the roller tubes in the ridge points.

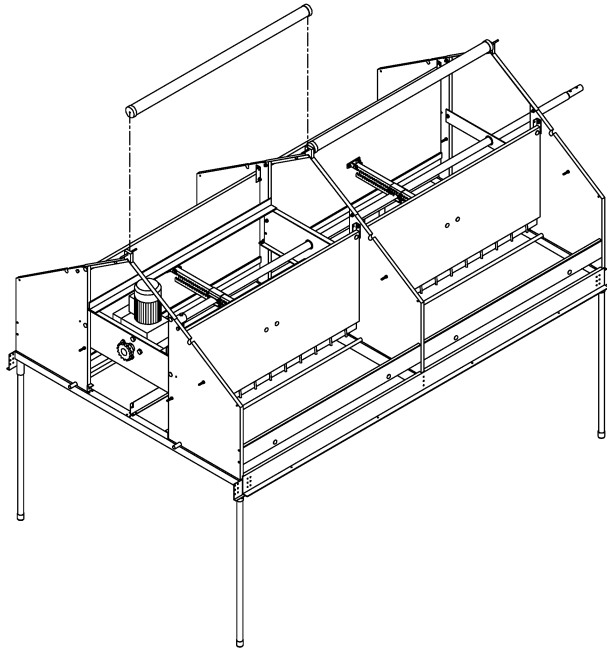

Fix the upper support beams (130389) between the partition walls with 2 hex bolts M6x30 (131030) and hex nuts M6.

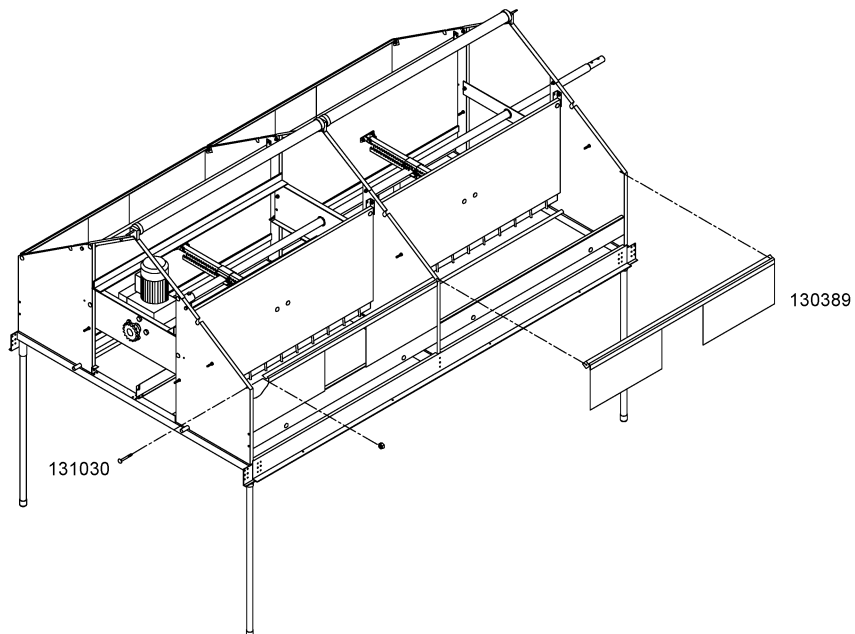

Place the 16 mm tubes in the recesses in the partition walls. Push the other 16 mm tubes through the trusses. Connect the tubes with PVC sleeves.

Attention: When pushing the tubes through the trusses, pull the cables for the flap motors through the tubes. Let the cables come out of the tubes when you reach the flap motors. The cables will be connected later.

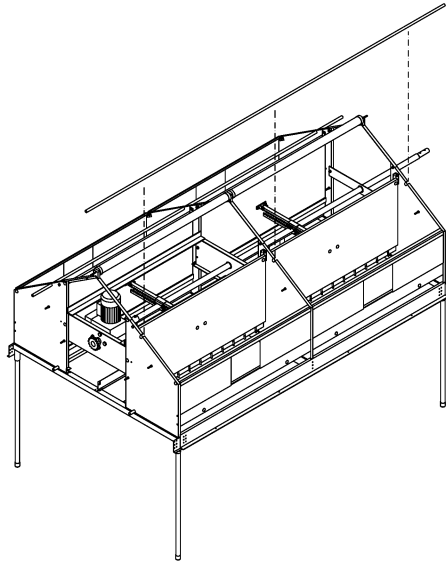

Place the roof plates (134341) on the nests. Set the roof plates into the slots of the upper support beams.

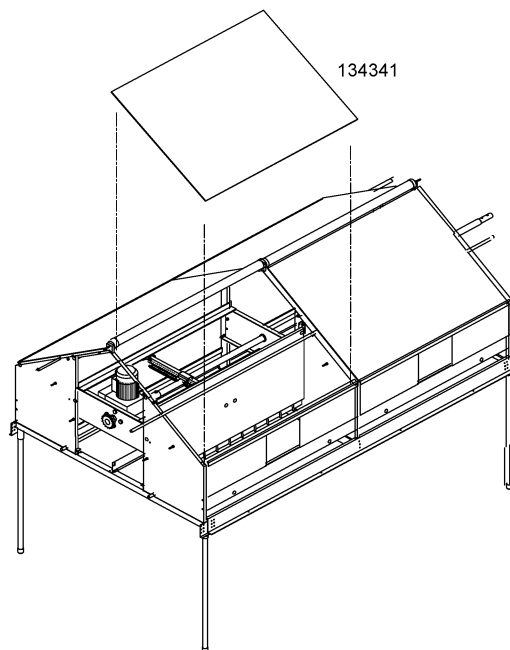

Screw the upper (130429) and lower (130428) endplates to the beginning and the end of the nest row, and if necessary to the beginning and the end of a walkover, with chipboard screws 4 mm diameter x 20 mm long (131033).

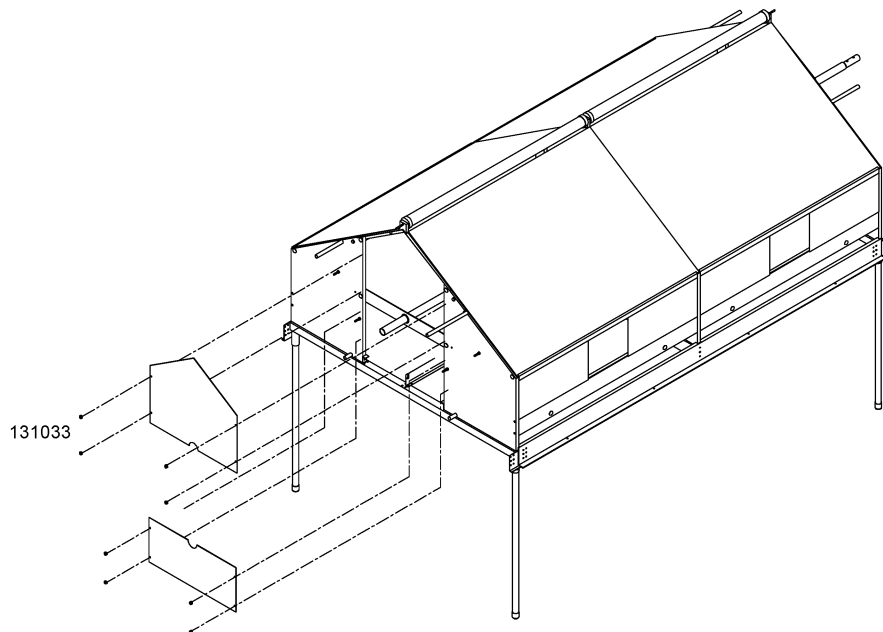

Fix the short belt guides (134364) to the first undercarriage with blind rivets 5 mm diameter x 8 mm long.

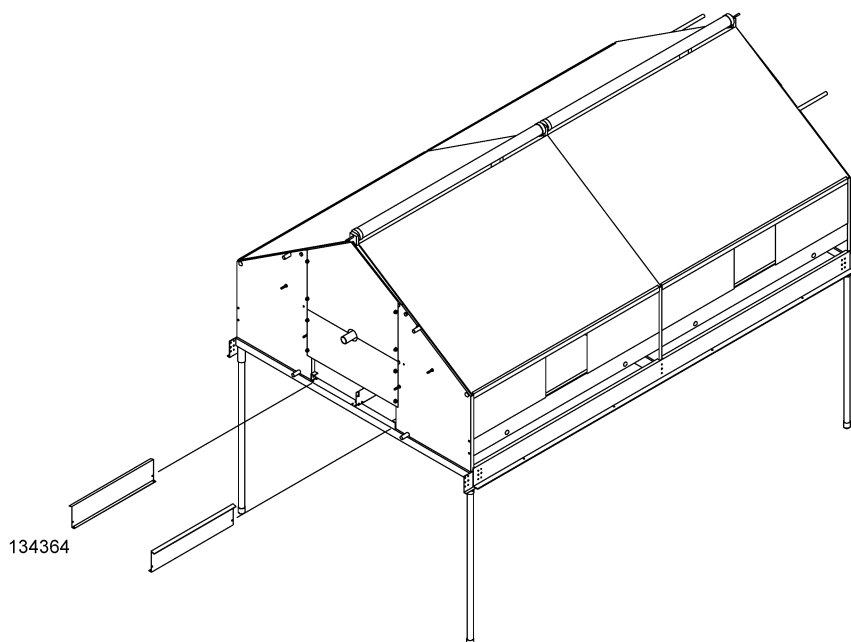

Assemble the drive unit:

- Insert the legs (314288) and secure with hex bolts M8x20 (631015).
- Fix the supports for the cover: hex bolts M6x45 (131031), spacer plugs (234327), 3xD lock washer M6 (311199) and hex nuts M6.
- Fix the table top (134358) with metal parker screw 5.5 mm diameter x 13 mm long (131215).
- Fix the guarding angle for the collecting table (134995) with metal parkers 5.5 mm diameter x 13 mm long.
- Fill the cover (134359) with 3xD lock washers M6 and hex bolts M6.
- Place the waste containers (assembly on next page).

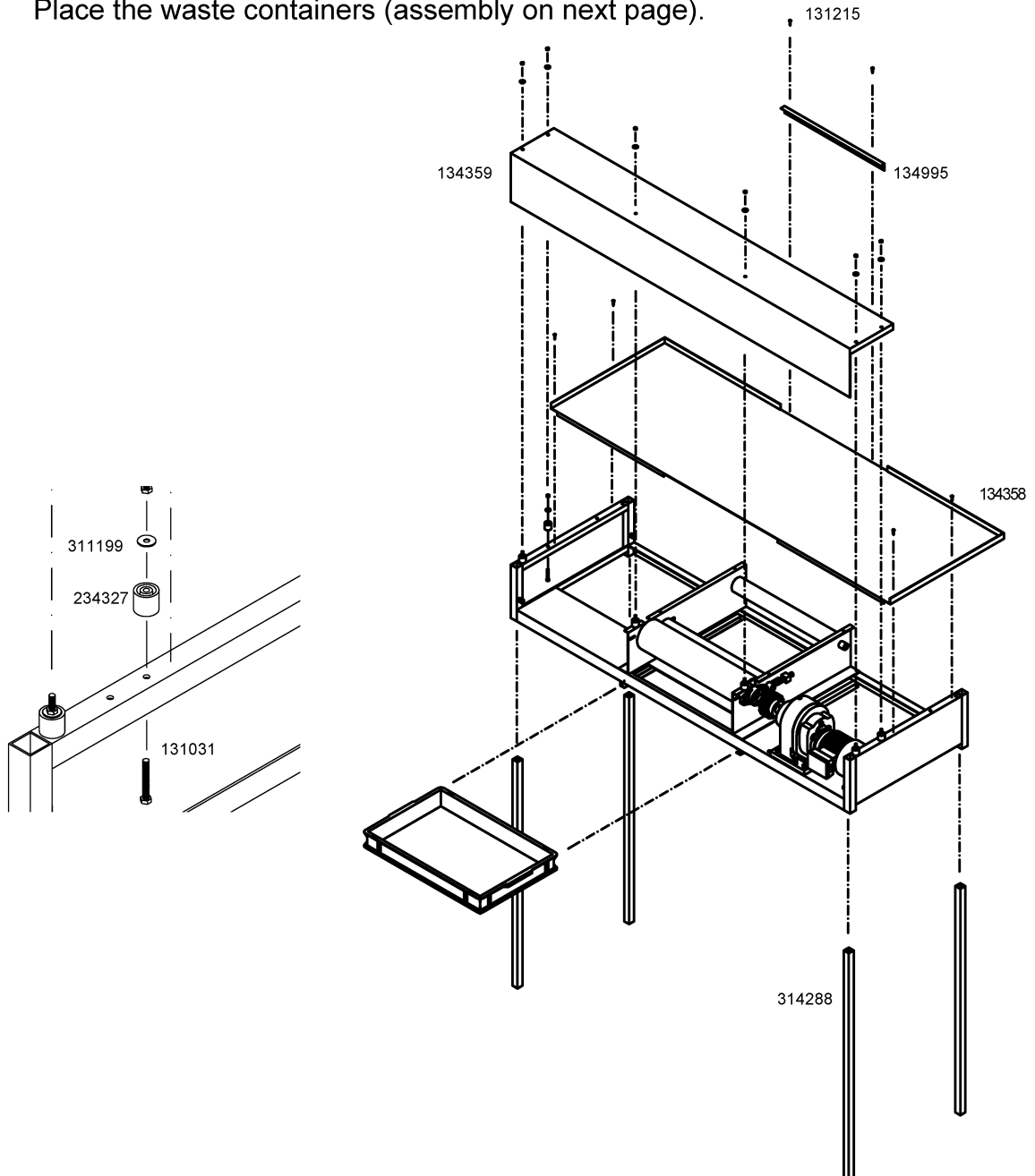

Assemble the waste container unit (2 x 136701) and attach it to the drive unit table by sliding into the channels provided.

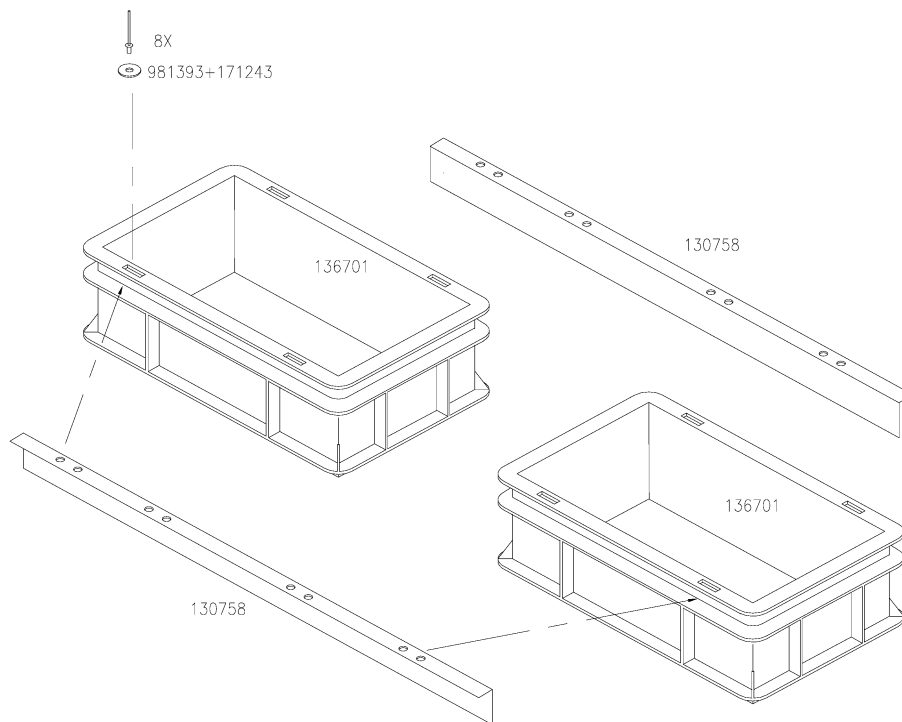

Screw the connecting strip for the connection of the table and the short belt guides (134363) to the table top with hex bolts M6x16 and hex nuts M6.

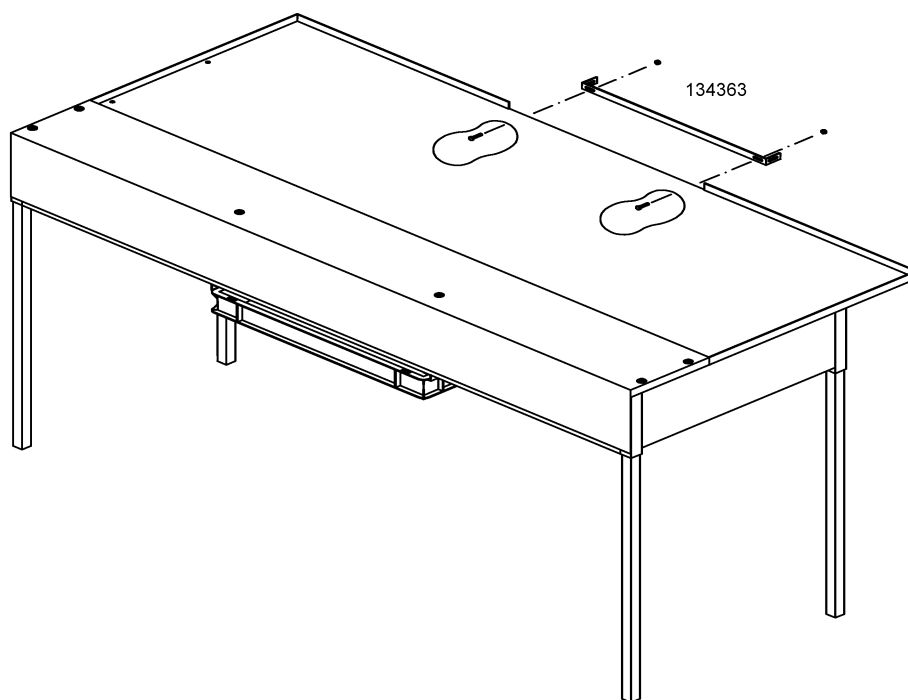

Connect the drive unit to the short belt guides.

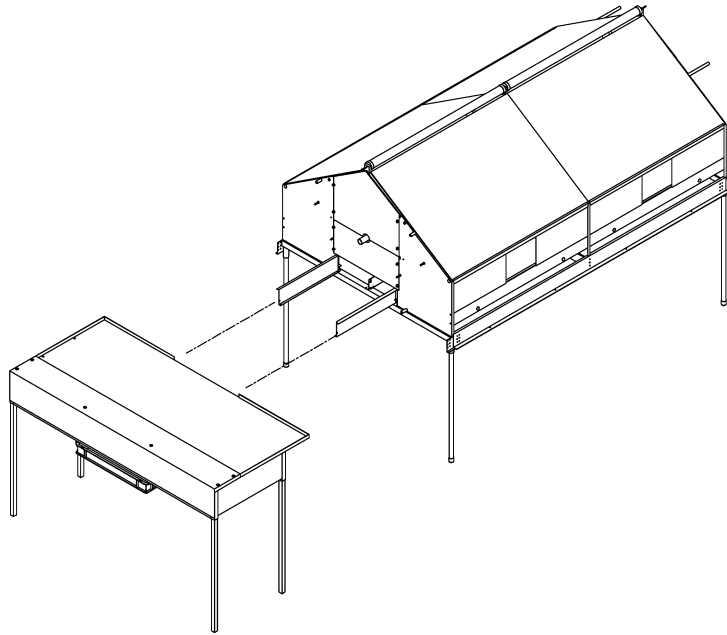

Weld the belts.

Connect the electrical box according to the electrical drawings.

Connect the motor and the end switches according to the electrical drawings.

Set the timer.

Your nests are ready for use.

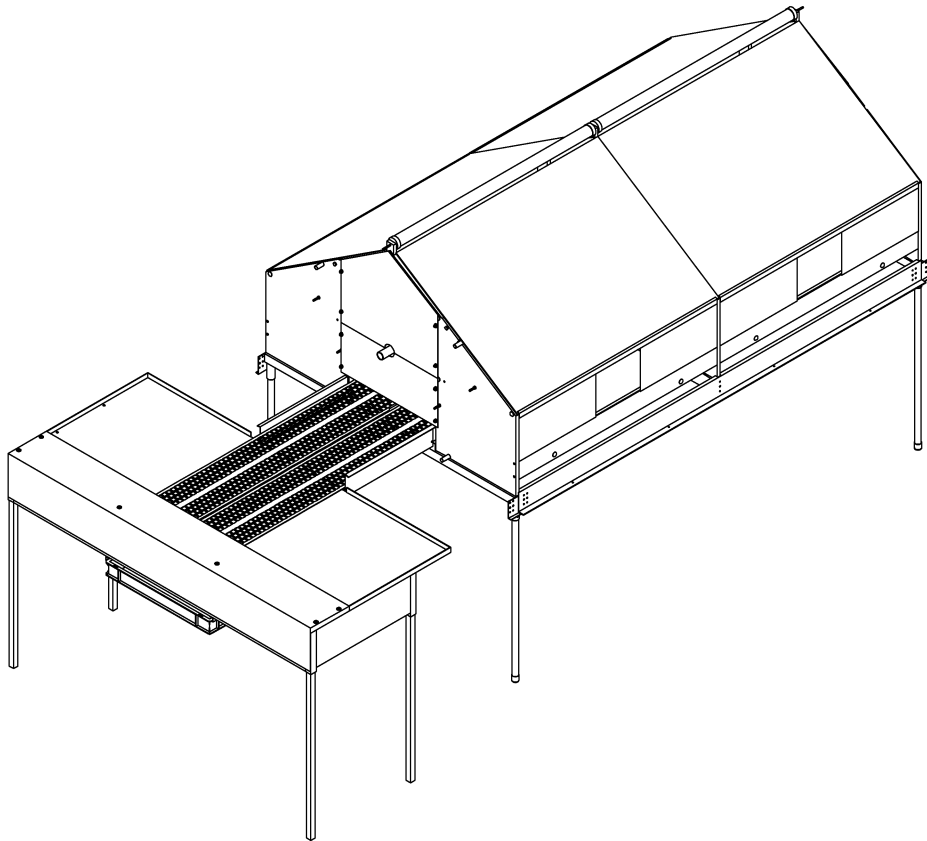



Appendix A: Setting the timer

Introduction

The LACRON timer is a programmable time switch with two channels. Channel A controls the nest flaps, and channel B controls the optional nest lights. The clock can be programmed to automatically open and close the nests, and switch on and off the nest lights.

Setting up a new clock

1. Before you use the clock, it must be powered for at least 1 minute to charge its internal battery.
2. Make sure that the toggle switches on the control panel are set to "Clock" and "Auto" to allow the clock to control the nest flaps and lights.
3. Press the two clear buttons ( and ) together. This resets the memory of the clock. The nest motors will run the flaps to the open position, and the nest lights will come on.

The clock should now read 06:00, with an "O" and a triangle shown beside both the "A" and "B" at the left of the display and is now ready to be programmed.

4. Set the current time.

Setting the current time

The Lacron clock uses 24 hour, or military time. For example, 9:00 a.m. will be displayed as 9:00, and 3:00 p.m. will be shown as 15:00.



Press this button once to start setting the time.



Set the day. Use Sunday as day 1, Monday is day 2, etc.



Set the hours, keeping in mind the 24 hour clock.



Set the minutes.









Store the time.

You are now ready to set the times that you wish your nest to open and close.







Programming the nests to open and close automatically

Programming the nests to close:

-  This button is the Program key. Press it until a small triangle appears beside the “A” on the left side of the display.
-  Command 'nests close'. An “I” will appear beside the triangle and the “A” in the display.
-  Press this key until all numbers 1-7 are lit at the bottom of the display.
-  Set the hours.
-  Set the minutes.
-  Press the enter key one time to store the program
-  Display the current time

You have just programmed the nests to close at the desired time on every day of the week. Next we can program the time to automatically open the nest.







Programming the nests to open:

-  Press this button until a small triangle appears beside the “A” on the left side of the display.
-  Command 'nests open'. An “O” will appear beside the triangle and the “A” in the display.
-  Press this key until all numbers 1-7 are lit at the bottom of the display.
-  Set the hours.
-  Set the minutes.
-  Press the enter key one time to store the program.
-  Display the current time

You have just programmed the nests to open at the desired time on every day of the week. The next step is to program the nest lights on and off.







Programming the optional nest lights to turn on and off automatically.

Programming the lights to turn off:

-  This button is the Program key. Press it until a small triangle appears beside the “B” on the left side of the display.
-  Command 'lights off'. An “I” will appear beside the triangle and the “B” in the display.
-  Press this key until all numbers 1-7 are lit at the bottom of the display.
-  Set the hours.
-  Set the minutes.
-  Press the enter key one time to store the program
-  Display the current time

The nest lights have now been programmed to turn off at the desired time.

Programming the lights to turn on:

-  Press this button until a small triangle appears beside the “B” on the left side of the display.
-  Command 'lights on'. An “O” will appear beside the triangle and the “B” in the display.
-  Press this key until all numbers 1-7 are lit at the bottom of the display.
-  Set the hours.
-  Set the minutes.
-  Press the enter key one time to store the program.
-  Display the current time

You have just programmed the lights to come on at the desired time.

Reviewing the programs

Press : 

The clock will show the number of free memory places. If the display reads "CL 28", this means there are 28 memory places free. There are 30 memory places available.

Once more, press: 

The clock now shows the first program's time and operation (For example if channel "A" shows an "O", the nests are programmed to open at the time displayed).

Every time you press this button, you will see the next programmed switch time.

When you press 
you will return to the time display.

Erasing a program

Press  until you reach the switch time you want to clear.

Press . The switch time will now be cleared (CM = Clear Memory).

Do not be afraid to start over from the beginning or try different things - you can do no damage to the clock or nest by programming it!

It may take 24 hours for the clock to "catch" all of the programs you have entered. If the clock has been disconnected for more than a few minutes, it may be necessary to reprogram the clock, starting from the beginning of this instruction.

Appendix B: Drive unit parts breakdown

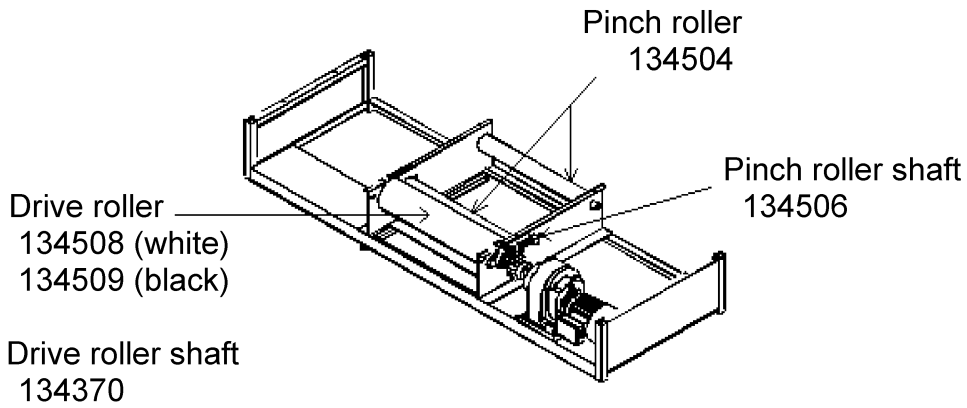

Motor & gearbox

Motor SK200-63L/4 (180W), n=7.9	137162
Motor SK250-71S/4 (250W), n=7.7	137164
Motor SK250-71L/4 (370W), n=7.7	137166

Electric motor only

El. motor NORD SK63L/4 (SK200)	137117
El. motor NORD SK71S/4 (SK200)	927176
El. motor NORD SK71L/4 (SK250)	137120

Options for connection to cross conveyor:

Rod conveyor table top	134360
Bracket to mount transfer brush	134361
Transfer brush	134362

Appendix C: Egg belt routing at return station

