

TROUBLE SHOOTING GUIDE

If you've installed and connected the unit as per the instructions listed earlier and it doesn't work properly, use the following table as a guide to fixing the problem. Look up the type of fault in the left column and check the possible causes from the right column.

#	Fault	Possible Causes
1	LED light source and indicating LED not lit	AC supply not connected; or AC supply turned off; or Unit not inserted into the base properly; or Test switch damaged
2	LED light source is lit but indicating LED not lit	Test switch damaged; or Battery not connected
3	The LED light source doesn't switch to emergency mode when the test button is pressed	Test switch damaged
4	The LED light source works momentarily on emergency when the test button is pressed	Battery not yet charged (allow up to 24 hours)

If the unit still doesn't work after checking these possible causes, contact Thomas & Betts Service in Australia on 1300 666 595, Monday to Friday, 8.30am to 4.30pm (AEST) and ask for help. Our trained service personnel will usually be able to take your call immediately and assist you in resolving your difficulty. Thomas & Betts is committed to providing valuable Through-Life Support for its products.



Thomas & Betts

A Member of the ABB Group

Thomas & Betts (Australasia) Pty. Ltd. ABN: 062 074 810 898
 Head Office: Unit D3, 3-29 Birnie Avenue, Lidcombe NSW 2141, Australia
 Manufacturing: 23a Nyrang Street, Lidcombe NSW 2141, Australia
 Phone: 1300 666 595 Fax: 1300 666 594 Email: austsales@tnb.com Website: www.tnbaust.com

Quickfit LED Exit 75K Installation Manual Standard

Contents	What's Inside the box
Electrical Safety Warning	Main Chassis & Diffuser Assembly
Installation Instructions	Ceiling Bracket Assembly
Removal Instructions	Pictograph Insert Pack
Testing Precautions	Hole Plug Set (6 Pieces)
Trouble Shooting Guide	Installation Manual
	Warranty Information

**GREETINGS**

Congratulations on choosing to use this Thomas & Betts product covered by our unique Through-Life Support system. This document is designed to assist you during the installation of this product; for the safety of yourself and others **Thomas & Betts recommends that you read this document thoroughly before commencing installation.** The fittings are designed for easy installation. They are advanced pieces of electronic equipment which, when treated with care and maintained through regular and appropriate servicing, will perform reliably for many years to come.

SAFETY WARNING

In Australia and New Zealand, only licensed electricians are permitted by law to work with 240 Volt electrical installations. Do not attempt to install or connect this product unless you are a licensed electrician. Turn off and isolate the electrical supply before connecting this fitting to the building wires. Do not touch the terminals of the terminal block when the light fitting is energised. The only user-serviceable parts are fluorescent or halogen lamp/s. LED light sources are not user-serviceable. Do not tamper with the fitting or the warranty will be void. As the installer, it is your responsibility to ensure compliance with all relevant building and safety codes, (ie: AS3000, AS/NZS2293). Refer to the applicable standards for data and mains cabling installation procedures and requirements.

Important Note: This product is designed for indoor use only.

INSTALLATION INSTRUCTIONS

1. Remove the unit from the packing box and inspect it for damage or imperfections. If any damage is found, do not install the unit, but replace it carefully into the packing box and notify the Thomas & Betts Product Support Hotline in Australia on 1300 666 595.
2. If all looks okay, installation can proceed. Take the mounting bracket and whilst holding it into place against the ceiling or wall, use a pencil to mark the position of the screw holes (at A or B in Figure 2) and cable entry position through the bracket onto the ceiling or wall as appropriate. Make sure to allow at least 50mm of free space to the right hand side of the final location of the unit to allow for the sliding function of attaching the unit to the mounting bracket. If need be, turn the bracket around and swap the diffuser with the back plate to permit room for inserting and removing the unit from the mounting bracket. Orient the bracket in such a way as to make the LED and push button readily visible and accessible when the unit is installed.
3. Remove the bracket to reveal the pencil marks and if the cabling is to be concealed, drill a 20mm hole for the cable entry prior to installing the bracket. Make sure the mounting screw locations are into solid material and strong enough to support the weight of the complete unit, (approx 2kg: build-up, strengthen or support the mounting material if necessary) and attach the bracket. Because of the wide variety of building construction materials and the wide variety of screw fasteners appropriate to each type, mounting screws are not provided with the unit. If appropriate and safe, drill and use your own fixing holes in the mounting bracket to suit the individual installation location and structural support needs of the unit, taking care not to obstruct the fitting slide entry.
4. Run the cables in the ceiling or wall space as appropriate or surface mounted in conduit and through the cable hole into the bracket. Strip, connect and terminate the cables as indicated in Figure 1. Ensure that the double insulation of the cable/s passes completely into the terminal block enclosure so that no single insulation is exposed when the cover is in place. The hole plug set includes a suitable bush to mechanically protect the cable as it passes through the opening in the mounting bracket. Likewise, the single insulation of the conductors should run right up to the metal edge of the terminals leaving no bare conductors outside of the terminals. Be careful with multi-strand conductors that all of the strands are twisted together before insertion into the terminal. Any stray strands that inadvertently come into contact with their neighbouring terminal or the metal frame of the fitting will cause undesirable results when the fitting is powered.

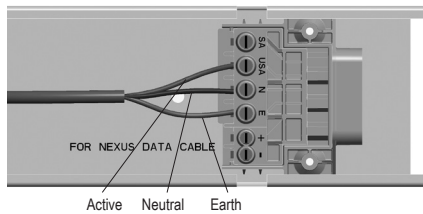

Figure 1: Quickfit Terminal Block Connection

- Neutral wire connects to terminal N
- Earth wire connects to terminal E
- For permanently illuminated fitting connect - active wire to terminal US/A
- For switched active fitting remove the link between SA & US/A terminal. Connect active wire to S/A and unswitched Active wire to US/A
- When connected, replace the terminal block cover so that it clicks and locks into place.

5. Attach the unit to the mounting bracket by aligning the top left hand end of the unit (the end without the protruding electrical connecting metal lugs) with the large cut-away slot towards the left hand end of the bracket. Slip the left hand end of the unit up into the slot in the left hand end of the bracket (Step (1) in Figure 2) and hold the unit horizontal to and parallel with the bracket. It should be approximately 50mm to the right of its final destination. Simply slide the unit (Step (2) in Figure 2) 50mm to the left along and into the bracket to engage the connections and the locking tab. Once in place, the unit cannot be removed from the bracket without the use of a tool (a small screwdriver) to push in the locking tab at 'D' in Figure 2. Ensure the correct pictograph inserts have been attached to the diffuser assembly.
6. Once powered up, the normal AC LED light source will energise and remain lit until the power supply fails. The emergency function of the light fitting will only operate when the normal lighting power supply fails or when somebody presses the manual test button located on the front of the unit. Red LED indicates that the power is connected and the battery is charging.

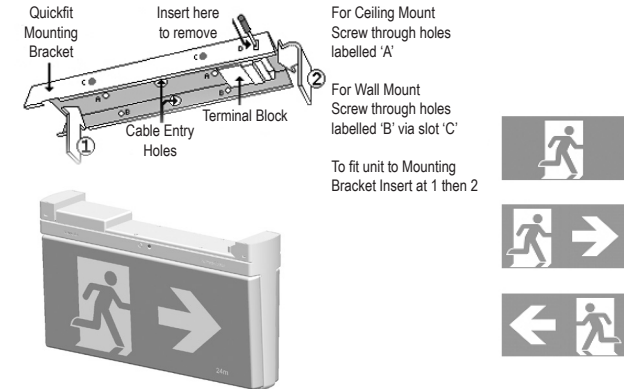

Figure 2: Quickfit Insertion Diagram & Internal View

Important Note: If installing this product into an early version ceiling bracket, first remove the two hole blanking plugs on the front face of the bracket and replace with the short hole plugs provided with the product.

REMOVAL INSTRUCTIONS

Gently insert a small screwdriver into the slot (at 'D' in Figure 2) on the front of the bracket towards the right hand end of the fitting, to ease the locking tab into the fitting and away from the bracket. The unit is then free to slide to the right along the bracket for about 50mm, at which time the slots line up and it can be lowered away from the bracket, allowing the two to separate. The unit will automatically switch into emergency mode because it has been removed from the power supply. It will stay on emergency until such time as the battery cut-off threshold is reached or it is reconnected back onto the power supply, whichever happens first. When the unit is reconnected to the supply, it will need time to recharge its battery before it will be capable of a full length discharge again. The ability of the unit to operate on emergency is determined by the age, charge level, operating temperature conditions and environmental circumstances of the battery in the unit.

TESTING PRECAUTIONS

If the unit is to be left permanently connected to the mains supply from now on, you will need to allow 24 hours for the battery to fully charge, after which you must conduct a manual discharge test as per the requirements of AS/NZS2293.2. Presently (at the time of writing), the standard requires that units operate in emergency mode for a period not less than 2 hours for their first test upon installation and for not less than 90 minutes thereafter once every 6 months. You will need to keep the records for the initial test and enter them into the building emergency services logbook. If the unit isn't permanently connected to mains supply at this time, it is your responsibility to carry out the initial 2 hour test when you do connect it permanently to the mains supply.

CONSTRUCTION SITES

Continuously switching on and off of the mains power supply that is connected to emergency light fittings, during the installation process (due to building works or for some other reason), could cause affected emergency light fittings to discharge and charge their batteries many times over a short period; this may shorten the life of the battery and may result in voiding of the battery warranty. Thomas & Betts does not recommend such practices and may not honour the warranty on batteries when they are subjected to such harsh operating conditions. Emergency light fittings are designed to be regularly discharge tested once every 6 months as per AS/NZS2293.2, deliberate repeated discharge testing over short periods of time is regarded as an abuse of the fittings.