

**PRECISE FLIGHT, INC.**  
**63120 POWELL BUTTE ROAD**  
**BEND, OR 97701**  
**800- 547-2558**

**PULSELITE® STARLIGHT**  
**INSTALLATION MANUAL**  
**MODEL 2401S**

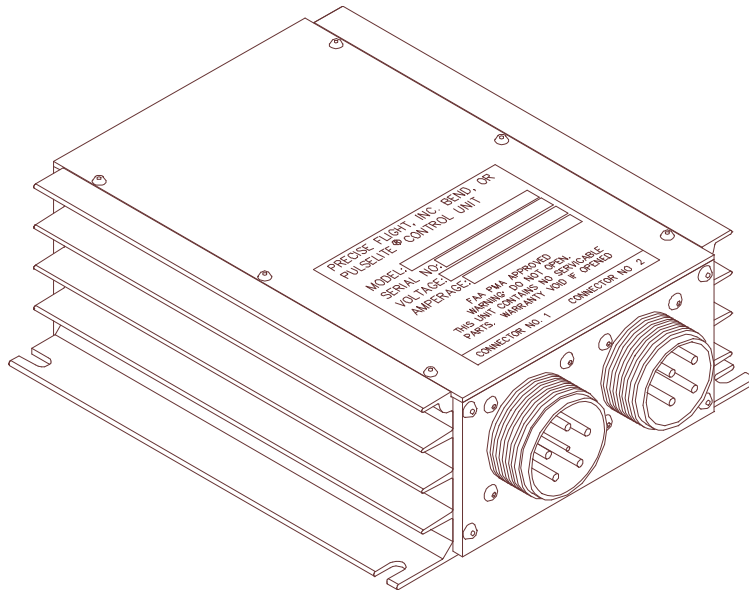

THIS DOCUMENT CONTAINS PROPRIETARY INFORMATION ON THE PRECISE FLIGHT, INC. COMPANY AND ITS RECEIPT OR POSSESSION DOES NOT CONVEY ANY RIGHTS TO REPRODUCE, DISCLOSE ITS CONTENTS, OR TO MANUFACTURE, USE, OR SELL ANYTHING IT MAY DESCRIBE. REPRODUCTION, DISCLOSURE, OR USE WITHOUT SPECIFIC WRITTEN AUTHORIZATION OF THE PRECISE FLIGHT, INC. COMPANY IS STRICTLY FORBIDDEN.





**PRECISE FLIGHT, INC.**  
**63120 POWELL BUTTE ROAD**  
**BEND, OR 97701**  
**800- 547-2558**

**PULSELITE® MODEL 2401S**

**TABLE OF CONTENTS**

<b>TABLE OF CONTENTS</b>	<b>II</b>
<b>LIST OF ACTIVE PAGES</b>	<b>IV</b>
<b>REVISIONS</b>	<b>V</b>
<b>1. GENERAL INFORMATION</b>	<b>1-1</b>
1.1. INTRODUCTION	1-1
1.2. PRODUCT DESCRIPTION	1-1
1.3. TECHNICAL CHARACTERISTICS	1-2
1.4. FACTORY SETTINGS	1-2
1.5. UNITS AND ACCESSORIES SUPPLIED	1-3
1.6. INSTALLATION APPROVAL BASIS	1-3
1.7. FIGURE - FAA FORM 337	1-4
1.8. ENVIRONMENTAL QUALIFICATIONS	1-5
1.9. FIGURE - ENVIROMENTAL TEST TABLE	1-5
1.10. AIRCRAFT CERTIFICATION	1-6
<b>2. INSTALLATION</b>	<b>2-1</b>
2.1. GENERAL	2-1
2.2. UNPACKING AND INSPECTION	2-1
2.3. INITIAL BENCH CHECK	2-1
2.4. COOLING	2-2
2.5. MECHANICAL INSTALLATION	2-2
2.5.1. Mechanical installation - Pulselite Control Unit.	2-2



**PRECISE FLIGHT, INC.**  
**63120 POWELL BUTTE ROAD**  
**BEND, OR 97701**  
**800- 547-2558**

## **PULSELITE® MODEL 2401S**

2.5.2.	Mechanical installation - Switches	2-3
<b>2.6.</b>	<b>FIGURE - PHYSICAL DIMENSIONS</b>	<b>2-4</b>
<b>2.7.</b>	<b>ELECTRICAL INSTALLATION</b>	<b>2-5</b>
2.7.1.	Electrical Installation	2-5
<b>2.8.</b>	<b>FIGURE - BLOCK DIAGRAM</b>	<b>2-6</b>
2.8.1.	Determine the amperage on individual channels.	2-7
<b>2.9.</b>	<b>FIGURE - WIRE TABLE</b>	<b>2-7</b>
<b>2.10.</b>	<b>FIGURE - PINOUT TABLE</b>	<b>2-8</b>
<b>2.11.</b>	<b>FIGURE - CONNECTOR CONFIGURATION</b>	<b>2-9</b>
<b>3.</b>	<b>TESTING</b>	<b>3-1</b>
3.1.	INSTALLATION TESTING	3-1
3.2.	EMI / RFI TESTING	3-2
3.2.1.	Procedures	3-3
3.2.2.	Communications	3-3
3.2.3.	Ground Navigation Systems	3-4
3.2.4.	Weather Radar	3-6
3.2.5.	Autopilot and Flight Director	3-6
3.2.6.	Conclusion	3-7
<b>4.</b>	<b>OPERATION</b>	<b>4-1</b>
4.1.	NORMAL OPERATION	4-1
<b>5.</b>	<b>DOCUMENTATION</b>	<b>5-1</b>
5.1.	DOCUMENTATION	5-1
5.2.	RETURN AUTHORIZATION	5-1
5.3.	WARRANTY SERVICE	5-1
<b>6.</b>	<b>APPENDIX A</b>	<b>6-1</b>
6.1.1.	PARTS LIST	6-1



PRECISE FLIGHT, INC.  
 63120 POWELL BUTTE ROAD  
 BEND, OR 97701  
 800- 547-2558

PULSELITE® MODEL 2401S

LIST OF ACTIVE PAGES

ORIGINAL		ADDED PAGES					
PAGE	REV	PAGE	REV	PAGE	REV	PAGE	REV
Title							
ii							
iii							
iv	C						
v	C						
1-1	A						
1-2							
1-3							
1-4							
1-5							
1-6							
1-7							
2-1							
2-2							
2-3	B						
2-4							
2-5							
2-6	C						
2-7	C						
2-8							
2-9							
2-10							
2-11							
2-12	A						
2-13							
2-14	A						
2-15							
3-1							
3-2							
3-3							
3-4							
3-5							
3-6							
3-7							
3-8							
4-1							
5-1							
6-1							



**PRECISE FLIGHT, INC.**  
**63120 POWELL BUTTE ROAD**  
**BEND, OR 97701**  
**800- 547-2558**

**PULSELITE® MODEL 2401S**

**REVISIONS**

<b>REV NO.</b>	<b>PAGE</b>	<b>DESCRIPTION</b>	<b>DATE</b>	<b>NAME</b>
A	1-1	Revise number of output channels	01/20/00	DJC
	2-12	Revise connector reference numbers	01/20/00	DJC
	2-14	Revise connector pinout	01/20/00	DJC
B	2-3	Revise switch function	11/27/00	DJC
	2-6	Revise Figure 2.8: Block Diagram	11/27/00	DJC
C	2-6	Revise Pulselite CB specification in diagram	02/15/01	MAO
	2-7	Revise wording to reflect values of circuit breaker	02/15/01	MAO



**PRECISE FLIGHT, INC.**  
**63120 POWELL BUTTE ROAD**  
**BEND, OR 97701**  
**800- 547-2558**

## **PULSELITE<sup>®</sup> MODEL 2401S**

### **1. GENERAL INFORMATION**

---

#### **1.1. INTRODUCTION**

This manual contains information regarding the physical, mechanical and electrical characteristics, as well as installation information pertaining to the Precise Flight **Pulselite Model 2401S Control Unit**. For maintenance and repair information, contact Precise Flight Inc.

#### **1.2. PRODUCT DESCRIPTION**

The Pulselite Model 2401S Control Units are a compact set of electrical components that will apply regulated pulsing power to the landing, taxi, or recognition lights instead of the normal steady on. The Pulselite connects easily to an aircraft's external lighting system, and may be installed on a wide variety of aircraft with differing light sequence combinations.

The control circuit of the Pulselite requires 24 / 28VDC. The four separate controlled power circuits of the 2401S Model are to pulse four DC Powered aircraft lamps (Up to 600 watts per Lamp).

Pulsing the landing lights enhances the aircraft flight path recognition quality and may be utilized any time the pilot desires. By flashing the landing, taxi, and recognition lights approx. 46 times per minute in a variety of patterns, the Pulselite Control Unit creates an illusion of exaggerated motion that other pilots can immediately recognize and avoid.

Precise Flight recommends that the landing lights be turned on steady (full time) when the aircraft is within 200' AGL at night. Due to possible disorientation the Pulselite should not be operated in clouds at night, or on the ground. The landing lights may be turned on steady rate, by simply switching the original landing/taxi/recognition lights on.



**PRECISE FLIGHT, INC.**  
**63120 POWELL BUTTE ROAD**  
**BEND, OR 97701**  
**800- 547-2558**

## **PULSELITE® MODEL 2401S**

### **1.3. TECHNICAL CHARACTERISTICS**

<b>Weight:</b>	<b>1.95 pounds 0.88 kilograms</b>
<b>Cooling:</b>	<b>Radiation and Convection</b>
<b>Dimensions:</b>	<b>5.45 in. W, 7.63 in. D, 2.18 in. H 13.84 cm W, 19.38 cm D, 5.54 cm H</b>
<b>Operating Voltages</b>	<b>28 VDC Control Voltage (11 - 29 VDC) 28 VDC Switching Voltage - Model 2401S</b>
<b>Operating Current</b>	<b>0.05 amps</b>
<b>Maximum Load per Switching Circuit</b>	<b>600 Watt DC</b>
<b>Number of circuits</b>	<b>4</b>
<b>Usage limitations</b>	<b>Less than 200 ft AGL at Night &amp; IMC Conditions</b>
<b>Ambient operating range</b>	<b>-50° F to +158° F -45° C to +70° C</b>

### **1.4. FACTORY SETTINGS**

<b>Pulse rate</b>	<b>43 - 48 Pulses per minute</b>
<b>Sequence normal</b>	<b>2 lights On - 2 lights off</b>
<b>Lamp brightness</b>	<b>Full power during Pulse (Slight resistance through Pulselite Control Unit)</b>





**PRECISE FLIGHT, INC.**  
**63120 POWELL BUTTE ROAD**  
**BEND, OR 97701**  
**800- 547-2558**

## **PULSELITE® MODEL 2401S**

### **1.5. UNITS AND ACCESSORIES SUPPLIED**

Pulselite Model 2401S Kit including:

- a) Pulselite Control Unit
- b) Copy of the Supplemental Type Certificate
- c) Switches or Switch Specification
- d) Wire Harness or Wiring Harness Drawing
- e) Installation Wiring Diagrams
- f) Installation Drawing

### **1.6. INSTALLATION APPROVAL BASIS**

The person who performs or supervises the installation of the Pulselite Model 2401S, may be required to prepare FAA form 337. See Fig. 1-7 for a Sample Description of Work

Accomplished. Data that can be used as a basis for approval for return to service are:

- A. AC 43.13-1A; Acceptable Methods, Techniques and Practices, Aircraft Inspection and Repair.
- B. AC 43.13-2A; Acceptable Methods, Techniques and Practices, Aircraft Alterations
- C. FAA approved Manufacturer's Installation Instructions.

Equipment installation procedures do not differ significantly among various aircraft. The installation and operation of the Pulselite Model 2401S does not materially affect the aircraft operation or performance.

The Sample Description of Work Accomplished (Figure 1-7) is suggested language provided as a convenience to the installing agency. The information and wording should be modified to correctly describe the particular installation.

Precise Flight Inc. can assume no responsibility for the alteration of the airframe or electrical system.



**PRECISE FLIGHT, INC.**  
**63120 POWELL BUTTE ROAD**  
**BEND, OR 97701**  
**800- 547-2558**

## **PULSELITE® MODEL 2401S**

### **8. Description of Work Accomplished**

*(If more space is required, attach additional sheets. Identify with aircraft nationality and registration mark and date work completed.)*

A. The following components were installed:

PULSELITE UNIT, MODEL 2401S, S/N  
SWITCH - (*Switch P/N*)

B. The Unit was installed in (*position in the aircraft*) according to instructions in the PRECISE FLIGHT INSTALLATION MANUAL MODEL 2401S, P/N dated (*insert current revision date of manual*), and guidance in FAA Advisory Circulars 43.13-1A, chapter 11, and 43.13-2A, Chapter 1 & 2.

C. An electrical load analysis was performed and the revised continuous load of the alternator (*generator or other supply*) does not exceed 80% of capacity.

D. A complete operational test was performed according to **PULSELITE** 2401S Installation Manual P/N 8034 date \_\_\_\_ . The equipment performed satisfactorily and did not adversely affect existing components or systems in the aircraft, as required by FAR 23.1301, FAR 23.1431 (or FAR 25.1301, FAR 25.1431, FAR 27.1301, FAR 27.1431 , FAR 29.1301 or FAR 29.1431 as applicable).

E. The aircraft equipment list was revised to reflect these changes; weight and balance data was revised and placed in the aircraft records. A Precise Flight Inc. PULSELITE Aircraft Flight Manual Supplement dated \_\_\_\_ was placed in the aircraft.

### **1.7. FIGURE - FAA FORM 337**



**PRECISE FLIGHT, INC.**  
**63120 POWELL BUTTE ROAD**  
**BEND, OR 97701**  
**800- 547-2558**

**PULSELITE® MODEL 2401S**

**1.8. ENVIRONMENTAL QUALIFICATIONS**

NOMENCLATURE PULSELITE  
 MODEL NUMBER: 2401S  
 MANUFACTURER SPECIFICATION: PULSELITE PERFORMANCE REQUIREMENTS  
 MANUFACTURER: PRECISE FLIGHT INC.  
 63120 POWELL BUTTE RD.  
 BEND, OR 97701

<b>CONDITIONS</b>	<b>DO160D SECTION</b>	<b>DESCRIPTION OF TESTS CONDUCTED</b>
TEMPERATURE AND ALTITUDE	4.0	CATEGORY D2
TEMPERATURE VARIATION	5.0	NOT REQUIRED
HUMIDITY	6.0	NOT REQUIRED
OPERATIONAL SHOCK AND CRASH SAFETY	7.0	NOT REQUIRED
VIBRATION	8.0	CATEGORY C
EXPLOSION	9.0	NOT REQUIRED
WATERPROOFNESS	10.0	CATEGORY W
FLUIDS SUSCEPTIBILITY	11.0	NOT REQUIRED
SAND AND DUST	12.0	NOT REQUIRED
FUNGUS	13.0	NOT REQUIRED
SALT SPRAY	14.0	NOT REQUIRED
MAGNETIC EFFECT	15.0	CLASS C
POWER INPUT	16.0	CATEGORY Z
VOLTAGE SPIKE CONDUCTED	17.0	CATEGORY A
AUDIO FREQUENCY CONDUCTED SUSCEPTIBILITY	18.0	CATEGORY Z
INDUCED SIGNAL SUSCEPTIBILITY	19.0	CATEGORY Z
RADIO FREQUENCY SUSCEPTIBILITY	20.0	CATEGORY A
RADIO FREQUENCY EMISSION	21.0	CATEGORY B

**1.9. FIGURE - ENVIROMENTAL TEST TABLE**



**PRECISE FLIGHT, INC.**  
**63120 POWELL BUTTE ROAD**  
**BEND, OR 97701**  
**800- 547-2558**

## **PULSELITE® MODEL 2401S**

### **1.10. AIRCRAFT CERTIFICATION**

Unless otherwise provided the Pulselite Model 2401S is approved by the following STC's.

1. Type of Certification: Supplemental Type Certificate
2. Certification Number: - NONE
3. Certification Basis: Approved Model Listing
4. Certification Date: NONE



**PRECISE FLIGHT, INC.**  
**63120 POWELL BUTTE ROAD**  
**BEND, OR 97701**  
**800- 547-2558**

## **PULSELITE® MODEL 2401S**

### **2. INSTALLATION**

---

#### **2.1. GENERAL**

The Pulselite Model 2401S should be installed according to this manual and AC 43.13-1A and -2A. Cable harnesses and mechanical supports must be fabricated by the installing agency to these requirements or supplied by Precise Flight for specific aircraft installations. This section contains interconnect diagrams, mounting dimensions, and other information pertaining to a Pulselite installation.

#### **2.2. UNPACKING AND INSPECTION**

Exercise care when unpacking the equipment. Make a visual inspection of the unit for evidence of damage incurred during shipment. If a claim for damage is to be made, save the shipping container to substantiate the claim. The claim should be filed with the transportation company. Retain the container and packaging material after the equipment has been removed, should equipment storage or reshipment become necessary.

#### **2.3. INITIAL BENCH CHECK**

Every Pulselite Model 2401S has been checked for operation before shipment. The installing agency can insure Pulselite operation before final installation by utilizing Paragraph 3.1 for this procedure.



**PRECISE FLIGHT, INC.**  
**63120 POWELL BUTTE ROAD**  
**BEND, OR 97701**  
**800- 547-2558**

## **PULSELITE® MODEL 2401S**

### **2.4. COOLING**

Elevated operating temperatures reduce reliability. Forced air-cooling is not required, however, allow approx. 1” of space around the control unit, for adequate convective cooling. Space is most critical on the unit sides so that the heat sink fins may dissipate heat at the proper rate.

### **2.5. MECHANICAL INSTALLATION**

Listed below are considerations to be examined before installing the Pulselite Model 2401S. Close attention to these suggestions will assure optimum performance when completed.

#### **2.5.1. Mechanical installation - Pulselite Control Unit.**

- A. Select a location for the Pulselite Control Unit, which is suitably ventilated for avionics. **CAUTION:** The standard Pulselite Model 2401S is not approved for use in a potentially explosive environment (refer to AC 43.13-2A, Chapter 2 - Radio Installation). Locate Pulselite away from fire hazard zones, highly explosive or corrosive areas, potentially hazardous fluid areas; e.g. water, fuel, hydraulic fluid, or oxygen units, etc.
- B. The Pulselite Control Unit must be installed in a structurally substantiated location. A typical wiring diagram and physical installation is provided in Appendix A.
- C. Allow adequate space for installation of cables and connectors.
- D. The Pulselite Control Unit should be installed in an avionics bay or other suitable location.
- E. Although the Pulselite Control Unit can be installed in any axis, the preferred orientation is with the fins vertical. Use 4 10-32 pan head screws. Burnish one fastener location to insure proper ground.



**PRECISE FLIGHT, INC.**  
**63120 POWELL BUTTE ROAD**  
**BEND, OR 97701**  
**800- 547-2558**

**PULSELITE® MODEL 2401S**

**2.5.2. Mechanical installation - Switches**

- A. The switch(s) should be located near the existing Aircraft Landing Light switches.



PRECISE FLIGHT, INC.  
63120 POWELL BUTTE ROAD  
BEND, OR 97701  
800- 547-2558

**PULSELITE® MODEL 2401S**

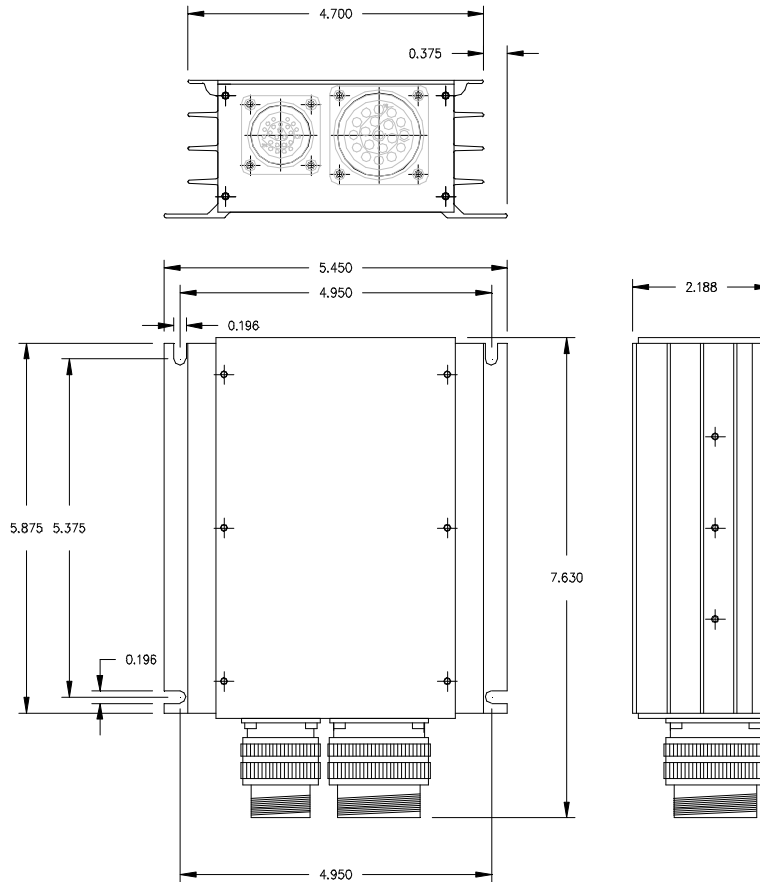

**2.6. FIGURE - PHYSICAL DIMENSIONS**





**PRECISE FLIGHT, INC.**  
**63120 POWELL BUTTE ROAD**  
**BEND, OR 97701**  
**800- 547-2558**

## **PULSELITE® MODEL 2401S**

### **2.7. ELECTRICAL INSTALLATION**

All wiring should be secured to prevent chafing and faulty connections. Refer to Advisory Circular 43.13-2A. NOTE: Precise Flight recommends that Mil-W-22759 wiring be utilized in the Pulselite installation.

**DO NOT USE ALUMINUM WIRE**

NOTE: Wiring precautions.

- A. Observe proper cable routing, i.e. avoid tie-wrap joining power lines to antenna leads, intercom, or radio leads.
- B. Be sure that all connections are sound, i.e. avoid frayed or split conduit ends.
- C. Avoid sharp bends or undue strain on cables

#### **2.7.1. Electrical Installation**

A. After the Pulselite Control Unit has been properly mounted determine the lighting pulse mode. Find the total wattage of the lamp(s) connected to the Pulselite Control Unit. Divide the highest total wattage by the voltage. The result will be the highest amperage rating on the Pulselite Control Unit. Amperages should not exceed 20 amps or 600 Watts DC. See Example below.



**PRECISE FLIGHT, INC.**  
**63120 POWELL BUTTE ROAD**  
**BEND, OR 97701**  
**800- 547-2558**

**PULSELITE® MODEL 2401S**

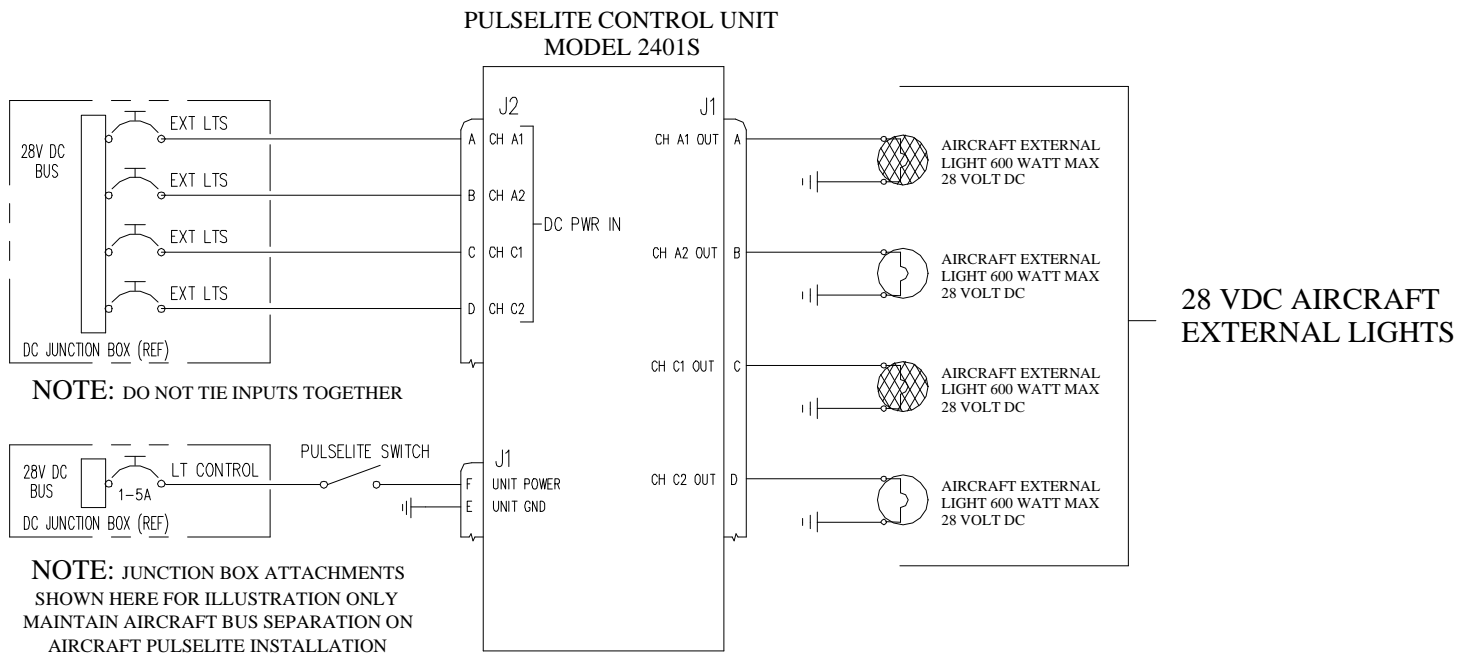

**2.8. FIGURE - BLOCK DIAGRAM**



**PRECISE FLIGHT, INC.**  
**63120 POWELL BUTTE ROAD**  
**BEND, OR 97701**  
**800- 547-2558**

**PULSELITE® MODEL 2401S**

**2.8.1.** Determine the amperage on individual channels.

Proper wire and circuit protection should be observed. SEE Fig. 2-9

<b>CU WIRE AN GAUGE</b>	<b>CIRCUIT BREAKER</b>	<b>FUSE</b>
22	5 amps	5 amps
20	7.5	5
18	10	10
16	15	10
14	20	15

**2.9. FIGURE - WIRE TABLE**

Approved wire specification is MIL-W- 22759/16 or equivalent. Fuse specification is MIL-F-15160 or equivalent. Circuit breaker specification is MIL-C-5809 or equivalent.

To protect the Pulselite control unit and insure proper installation, it is important to check that ground terminal, connector #1, pin "E", of the control unit is properly grounded to the aircraft frame with a No. 20 gauge wire or equivalent ground strap. Chassis of unit should be mounted to airframe and interfaces burnished to ensure a good ground.

Power input for the Pulselite Control Unit is through Connector #1 Pin "F". A single 1 to 5 Amp circuit breaker is required between the aircraft bus and this pin. This pin provides internal control voltage for the Pulselite Control Unit.

The Pulselite circuit breaker(s) should be located in the existing aircraft circuit breaker panel. However, if this is not possible, they may be located within the Pulselite switch panel.



PRECISE FLIGHT, INC.  
 63120 POWELL BUTTE ROAD  
 BEND, OR 97701  
 800- 547-2558

**PULSELITE® MODEL 2401S**

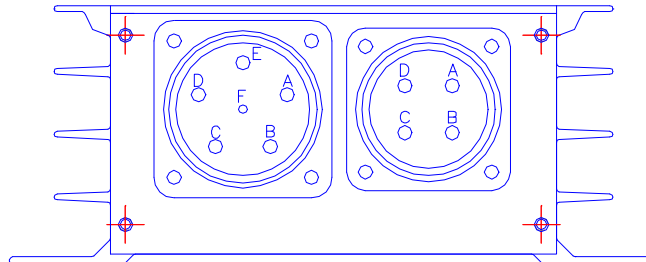

PULSELITE CONNECTOR PINOUT TABLE							
CONNECTOR 1 - SHELL SIZE 20 MS3102 20-17 - P				CONNECTOR 2 - SHELL SIZE 18 MS3102 18-10 - P			
PIN	VOLTAGE	FUNCTION	CHNL	PIN	VOLTAGE	FUNCTION	CHNL
A	28V DC	DC OUTPUT	A1	A	28V DC	DC INPUT	A1
B	28V DC	DC OUTPUT		A2	B	28V DC	
C	28V DC	DC OUTPUT	C1	C	28V DC	DC INPUT	C1
D	28V DC	DC OUTPUT	C2	D	28V DC	DC INPUT	C2
E	DC GND	UNIT GROUND					
F	28 VDC	CONTROL POWER					
MATING CONNECTOR MS 3106A-20 / 97-20-17-S				MATING CONNECTOR MS 3106B-18 / 97-18-10-S			

**2.10. FIGURE - PINOUT TABLE**



PRECISE FLIGHT, INC.  
63120 POWELL BUTTE ROAD  
BEND, OR 97701  
800- 547-2558

**PULSELITE® MODEL 2401S**

**2.11. FIGURE - CONNECTOR CONFIGURATION**

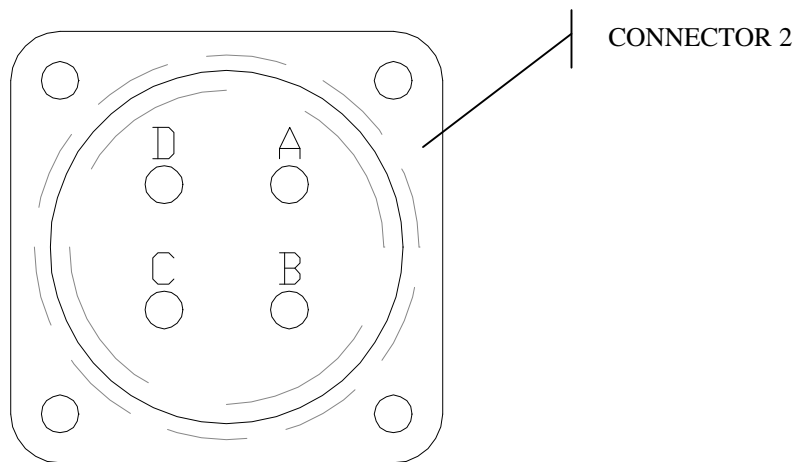
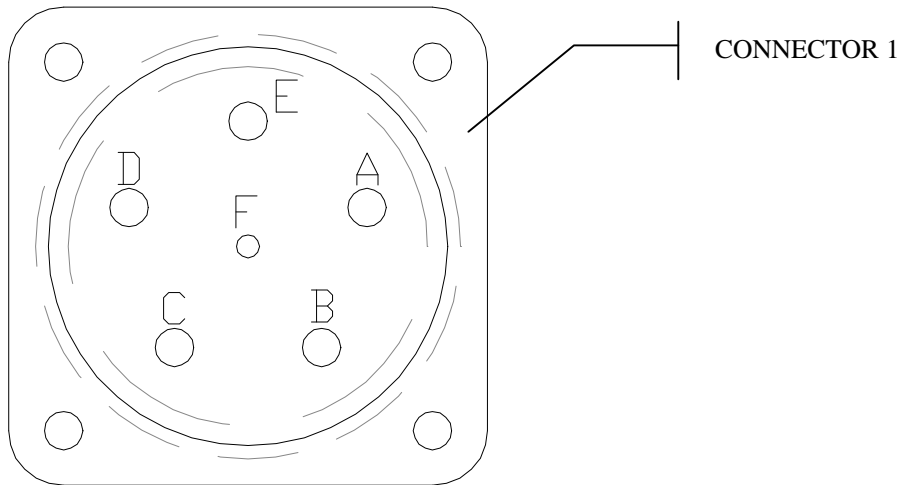



**PRECISE FLIGHT, INC.**  
**63120 POWELL BUTTE ROAD**  
**BEND, OR 97701**  
**800- 547-2558**

## **PULSELITE® MODEL 2401S**

### **3. TESTING**

---

#### **3.1. INSTALLATION TESTING**

The following test procedure will evaluate the installation in the aircraft:

1. Check wiring & connections before applying power
2. Switch the Pulselite Unit to ON and verify that the appropriate Landing / Taxi / Recognition Lights are flashing on the aircraft.
3. Switch the appropriate Landing/ Taxi / Recognition Lights ON utilizing the existing switches and verify that the lights remain on without flashing.
4. Switch the Pulselite Control Unit off and the existing Landing/ Taxi / Recognition Light switches are off and verify that the Landing/ Taxi/ Recognition Lights are OFF.



**PRECISE FLIGHT, INC.**  
**63120 POWELL BUTTE ROAD**  
**BEND, OR 97701**  
**800- 547-2558**

## **PULSELITE® MODEL 2401S**

### **3.2. EMI / RFI TESTING**

The following is an outline for determining that no detrimental Electro Magnetic Interference (EMI) or Radio Frequency Interference (RFI) is caused by the installation of a Precise Flight Pulselite product per FAR 23.1431, 25.1431, 27.1431 or 29.1431.

These procedures are not necessarily all encompassing in that they may not include all of the equipment installed in the airplane. If electronic and navigation equipment is installed which is not included in this document, consult the equipment manufacturer, an FAA approved repair station rated in the equipment involved, or an FAA Avionics Inspector for applicable test procedures.

The evaluation will be with a series of equipment checks, on the ground, to determine that no detrimental EMI/RFI effects are introduced into the aircraft by the Pulselite system.

The electrical systems installed in the aircraft will be referred to as the Pulselite system in this procedure.

The following tests should be performed by personnel familiar with aircraft systems and proper operation as well as the Pulselite equipment and its proper operation.

Any and all discrepancies shall be noted. Any discrepancies noted during these procedures must be reported to Precise Flight, Inc. and evaluated for cause, extent and as to what corrective action should be taken to correct the problem. The aircraft may not be flown after discrepancies are found unless the Pulselite system is disconnected at the aircraft bus until such time as the problems have been corrected and the aircraft has successfully passed the ground portion of this test. Only then may the aircraft be flown to complete this test.



**PRECISE FLIGHT, INC.**  
**63120 POWELL BUTTE ROAD**  
**BEND, OR 97701**  
**800- 547-2558**

## **PULSELITE® MODEL 2401S**

A record of this test shall be recorded in the aircraft logbook. The entry should include date, aircraft time, and results including any discrepancies note. The ground test results shall be recorded in the permanent aircraft records by the installing mechanic or a mechanic with the proper ratings.

### **3.2.1. Procedures**

During the following tests, the aircraft shall be supplied with adequate aircraft power at or above the minimum bus voltage for the aircraft. The airplane should be located for proper radio reception and radar operation, usually outside.

### **3.2.2. Communications**

A. Select Comm. 1 to a local frequency in the lower end of the COMM frequency band. Check for clarity of reception and background noise with all Pulselite equipment operating. Repeat for all Comm radios.

Remarks: \_\_\_\_\_

B. Select Comm. 1 to a local frequency in the upper end of the COMM frequency band. Check for clarity of reception and background noise with all Pulselite equipment operating. Repeat for all Comm radios.

Remarks: \_\_\_\_\_





**PRECISE FLIGHT, INC.**  
**63120 POWELL BUTTE ROAD**  
**BEND, OR 97701**  
**800- 547-2558**

## **PULSELITE® MODEL 2401S**

- C. Verify that the intercom is free from noise and interference caused by the Pulselite installation.

Remarks: \_\_\_\_\_

### **3.2.3. Ground Navigation Systems**

#### **A. VOR/DME**

1. Select VOR 1 receiver to a local frequency, center CDI needle of HSI with "TO" indication. Listen for background noise.
2. Switch Pulselite equipment on and off, check for interference and needle deviation.
3. Repeat for all other VHF NAV radios.
4. Tune VOR Nav 1 to a local VORTAC station with Pulselite equipment off. Note distance on DME and listen for noise. Turn Pulselite equipment on and compare distance readings and background noise.

Repeat for all other VHF NAV radios.

Remarks: \_\_\_\_\_

#### **B. Loran C**

1. Observe Loran self test responses and signal to noise ratios. Turn Pulselite equipment on and recycle Loran and compare results.

Remarks: \_\_\_\_\_



**PRECISE FLIGHT, INC.**  
**63120 POWELL BUTTE ROAD**  
**BEND, OR 97701**  
**800- 547-2558**

**PULSELITE® MODEL 2401S**  
C. RNAV

1. VOR MODE - Set to VHF on a local frequency, center CDI and pilots HSI, turn on Pulselite equipment and check for interference.

Remarks: \_\_\_\_\_

2. DME MODE - With Pulselite equipment off, set to local VHF frequency and note DME reading. Turn on Pulselite equipment and compare DME reading. Verify reading with known distance.

Remarks: \_\_\_\_\_

3. RNAV MODE - With Pulselite equipment off, set local VHF frequency, set waypoint bearing to 180 and waypoint distance to 25 miles. Center CDI and note RNAV readings. Turn Pulselite equipment on and note any changes in RNAV readings.

Remarks: \_\_\_\_\_



**PRECISE FLIGHT, INC.**  
**63120 POWELL BUTTE ROAD**  
**BEND, OR 97701**  
**800- 547-2558**

**PULSELITE® MODEL 2401S**

C. Magnetic Compass

With Pulselite equipment OFF, note compass heading. Turn Pulselite equipment ON and compare compass heading.

**THIS TEST MUST BE REPEATED WITH THE AIRCRAFT HEADED IN FOUR DIRECTIONS APPROXIMATELY 90 DEGREES APART.**

Compass Readings				
Heading	Position 1	Position 2	Position 3	Position 4
Pulselite ON				
Pulselite OFF				

Remarks: \_\_\_\_\_

**3.2.4. Weather Radar**

**CAUTION!**  
**USE CAUTION WHEN OPERATING RADAR! FOLLOW RADAR MANUFACTURERS RECOMMENDATIONS FOR SAFETY.**

A. Select "WxRadar ON". After proper warm up time, select "TEST" mode and confirm proper operation. Select "MAP" mode and note display. Turn on Pulselite equipment and note any changes.

Remarks: \_\_\_\_\_

**3.2.5. Autopilot and Flight Director**

Turn on autopilot and perform ground check per the autopilot manufacturers instructions in the flight manual. Turn on the Pulselite equipment and again perform check. Note any discrepancies.

Remarks: \_\_\_\_\_



**PRECISE FLIGHT, INC.**  
**63120 POWELL BUTTE ROAD**  
**BEND, OR 97701**  
**800- 547-2558**

**PULSELITE® MODEL 2401S**

**3.2.6. Conclusion**

<b>EMI Test Data Record</b>		
<b>Date:</b>		
<b>Make:</b>		
<b>Model:</b>		
<b>Ser. No:</b>		
<b>Witness:</b>		<b>Date:</b>
<b>Location:</b>		

Comments: \_\_\_\_\_



**PRECISE FLIGHT, INC.**  
**63120 POWELL BUTTE ROAD**  
**BEND, OR 97701**  
**800- 547-2558**

## **PULSELITE® MODEL 2401S**

### **4. OPERATION**

---

#### **4.1. NORMAL OPERATION**

Pulsing the landing lights tend to enhance the aircraft flight path recognition quality and may be utilized any time the pilot desires. By flashing the landing, taxi, and recognition lights approx. 46 times per minute in a variety of patterns, Pulselite creates an illusion of exaggerated motion that other pilots can immediately recognize and avoid.

While the Pulselite has been tested throughout the entire landing phase of flight, Precise Flight recommends that the landing lights be turned on steady (full time) when the aircraft is within 200' AGL at night. The Pulselite system should not be operated in clouds at night or in the close proximity of other aircraft on the ground, due to possible disorientation. The landing lights may be turned on steady at any time by simply switching the original landing/taxi/recognition lights on. The Pulselite will remain active until the Pulselite switch is turned OFF.



**PRECISE FLIGHT, INC.**  
**63120 POWELL BUTTE ROAD**  
**BEND, OR 97701**  
**800- 547-2558**

## **PULSELITE® MODEL 2401S**

### **5. DOCUMENTATION**

---

#### **5.1. DOCUMENTATION**

To ensure technical updates and notifications, **fill out and return the warranty document** and a copy of the 337, if appropriate.

#### **5.2. RETURN AUTHORIZATION**

In order to expedite repair of units, call the factory for a return authorization number before returning equipment for service.

#### **5.3. WARRANTY SERVICE**

Precise Flight warrants products in accordance with the warranty statement in effect at the time of equipment registration. All repairs are performed at the factory. Contact Precise Flight Inc. for a warranty / return authorization. All requests for warranty payment must be submitted on a standard warranty claim form, accompanied by the dealer invoice. Authorized warranty work performed by the dealer will be limited to removal and re-installation of units on an exchange basis. Precise Flight Inc. will bear the cost of warranty returns both ways via **UPS** surface delivery only. Precise Flight reserves the right to use reconditioned parts in repairing the product or to use reconditioned units as warranty replacements.

For technical information and service, call 1-800-547-2558.



PRECISE FLIGHT, INC.  
63120 POWELL BUTTE ROAD  
BEND, OR 97701  
800- 547-2558

PULSELITE<sup>®</sup> MODEL 2401S

## 6. APPENDIX A

---

### 6.1.1. PARTS LIST