

Versatec Base

Commercial 0.5 to 6 Ton
Geothermal/Water Source Heat Pump

Installation Information

Water Piping Connections

Electrical

Startup Procedures

Troubleshooting

Preventive Maintenance



Versatec Base Series Installation Manual



IM1201AUB 05/14

Table of Contents

Model Nomenclature	4
General Installation Information	5
Dimensional Data	6-9
Installing Horizontal Units.	10
Hanger Bracket Locations.	11
Duct System and Water Piping	12
Water Quality	13
Condensate Drain.	13
System Cleaning and Flushing.	14
Open Loop Ground Water Systems	15
Freeze Detection	16
Electrical Connections.	16
Electrical Data	17-18
Blower Performance Data.	19-22
5-Speed ECM Constant Torque Motors	23
Wiring Schematics	24-29
Controls - Aurora Base Control	30-33
Controls - UPC (optional)	34-39
Unit Startup	40
Operating Parameters and Operating Limits	41
Pressure Drop	42
Compressor and Thermistor Resistance	43
Refrigerant Circuit Guideline	43
Heat of Extraction/Rejection Data	44
Reference Calculations and Legend	45
Troubleshooting	46
Startup/Troubleshooting Form	47-48
Preventive Maintenance	49
Replacement Procedures	49
Service Parts	50-51
Revision Guide.	53

Model Nomenclature

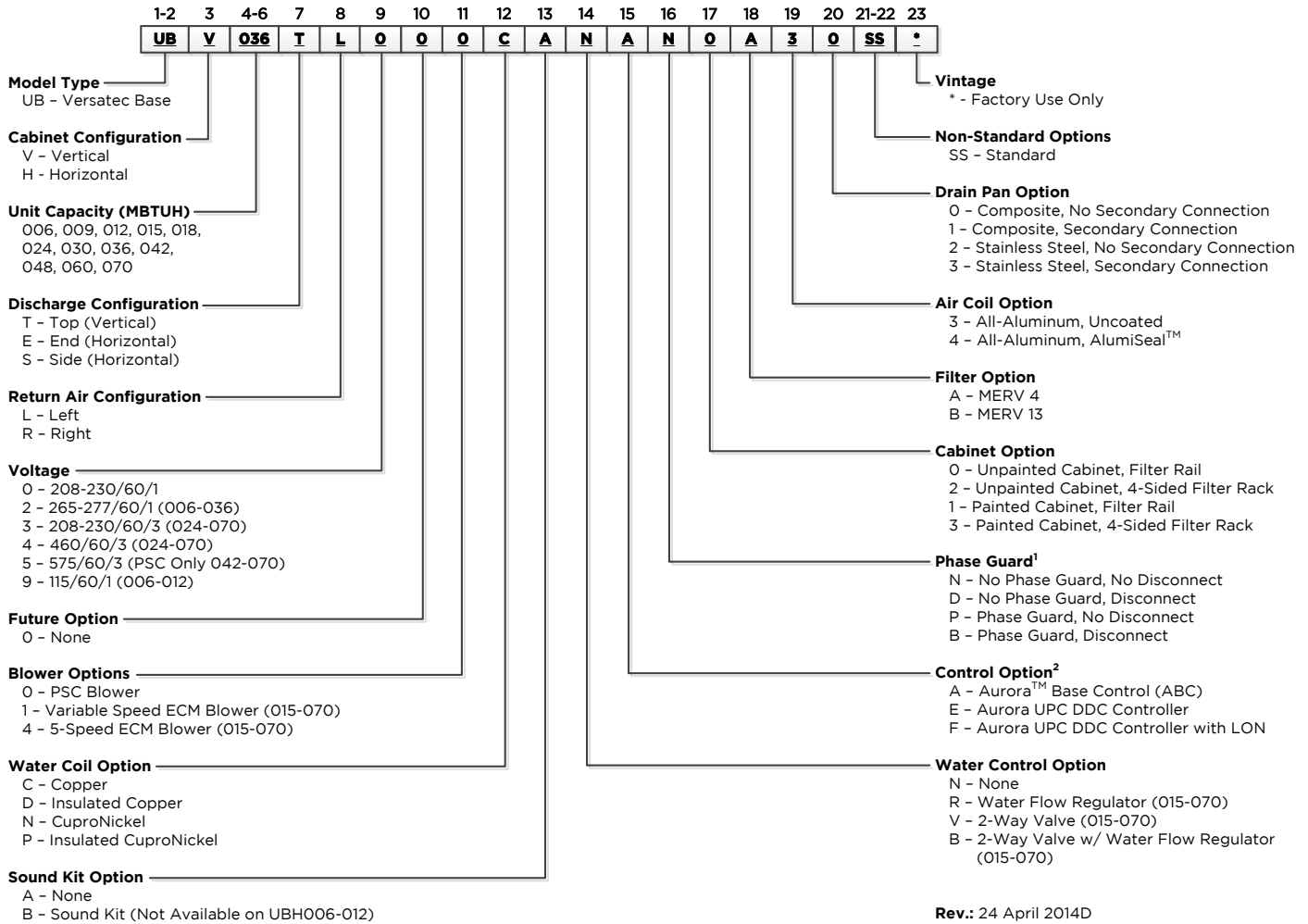

Note:
1 - Phase Guard Only Available on 208-230/60/3, 460/60/3, and 575/60/3
2 - 50VA transformer with Aurora Base Control, and 75VA transformer with Aurora UPC control



All Versatec Base Series product is safety listed under UL1995 thru ETL and performance listed with AHRI in accordance with standard 13256-1.

General Installation Information

Safety Considerations



WARNING: Before performing service or maintenance operations on a system, turn off main power switches to the indoor unit. If applicable, turn off the accessory heater power switch. Electrical shock could cause personal injury.

Installing and servicing heating and air conditioning equipment can be hazardous due to system pressure and electrical components. Only trained and qualified service personnel should install, repair or service heating and air conditioning equipment. Untrained personnel can perform the basic maintenance functions of cleaning coils and cleaning and replacing filters. All other operations should be performed by trained service personnel. When working on heating and air conditioning equipment, observe precautions in the literature, tags and labels attached to the unit and other safety precautions that may apply.

Follow all safety codes. Wear safety glasses and work gloves. Use a quenching cloth for brazing operations and have a fire extinguisher available.

Moving and Storage

Move units in the normal “up” orientation. Horizontal units may be moved and stored per the information on the packaging. Do not stack more than three units in total height. Vertical units may be stored one upon another to a maximum height of two units. Do not attempt to move units while stacked. When the equipment is received, all items should be carefully checked against the bill of lading to be sure all crates and cartons have been received. Examine units for shipping damage, removing the units from the packaging if necessary. Units in question should also be internally inspected. If any damage is noted, the carrier should make the proper notation on the delivery receipt, acknowledging the damage.

Unit Location

Locate the unit in an indoor area that allows for easy removal of the filter and access panels. Location should have enough space for service personnel to perform maintenance or repair. Provide sufficient room to make water, electrical and duct connection(s). If the unit is located in a confined space, such as a closet, provisions must be made for return air to freely enter the space by means of a louvered door, etc. Any access panel screws that would be difficult to remove after the unit is installed should be removed prior to setting the unit. On horizontal units, allow adequate room below the unit for a condensate drain trap and do not locate the unit above supply piping. **Care should be taken when units are located in unconditioned spaces to prevent damage from frozen water lines and excessive heat that could damage electrical components.**

Installing Vertical Units

Vertical units are available in left or right air return configurations. Top flow vertical units should be mounted level on a vibration absorbing pad slightly larger than the base to provide isolation between the unit and the floor.

Vertical Unit Mounting

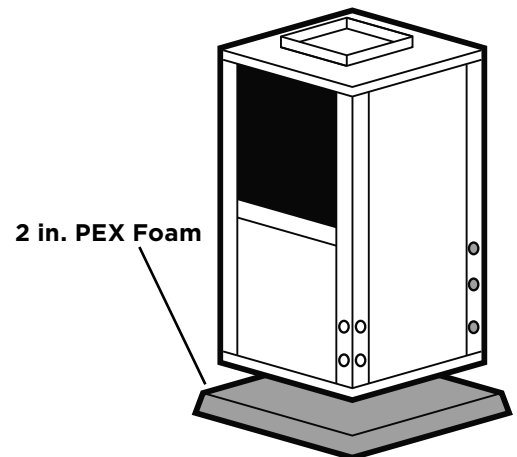

Vertical Dimensional Data

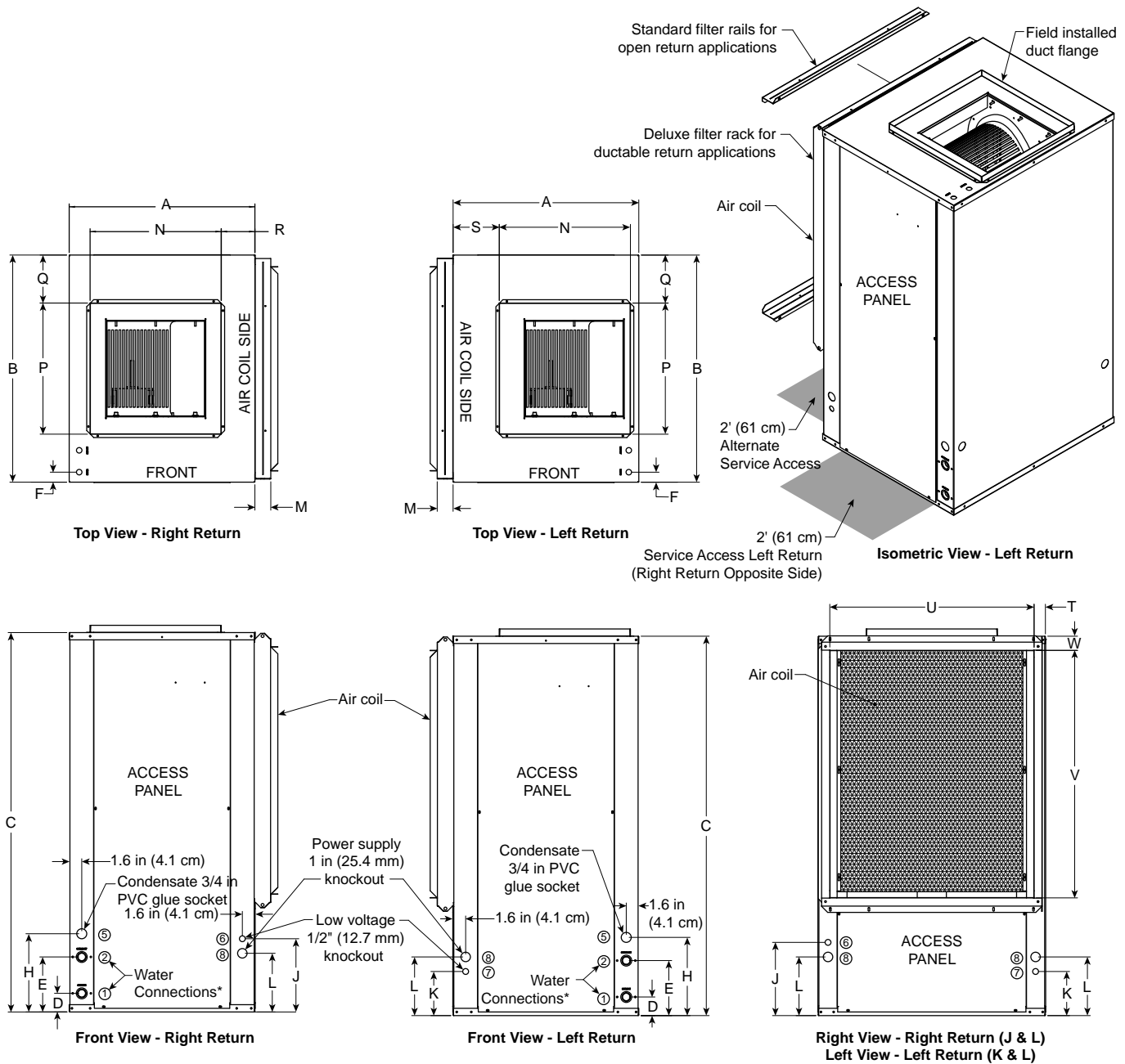

NOTE: * Water connections protrude approximately 1.5 in. from cabinet.

Vertical Dimensional Data cont.

Vertical Models	Overall Cabinet			Water Connections				Electrical Knockouts			M Filter Rack Width	
	A	B	C	1	2	5	Loop	6	7	8		
				D	E	H		J	K	L		
	Width	Depth	Height*	In	Out	Condensate	Water FPT	1/2 in. cond Low Voltage	1/2 in. cond Low Voltage	1 in. cond Power Supply		
006-012	in.	19.2	19.2	24.2	2.6	5.6	8.8	1/2 in.	7.4	3.4	5.4	2.2
	cm.	48.8	48.8	61.5	6.6	14.2	22.4	12.7 mm	18.8	8.6	13.7	5.6
015-018	in.	22.5	22.2	30.2	2.6	7.6	10.8	3/4 in.	9.4	5.4	7.4	2.2
	cm.	57.2	56.4	76.7	6.6	19.3	27.4	19.1 mm	23.9	13.7	18.8	5.6
024-030	in.	22.5	22.2	36.2	2.6	7.6	10.8	3/4 in.	9.4	5.4	7.4	2.2
	cm.	57.2	56.4	91.9	6.6	19.3	27.4	19.1 mm	23.9	13.7	18.8	5.6
036	in.	22.5	26.2	40.2	2.6	7.6	10.8	3/4 in.	10.1	6.1	8.1	2.2
	cm.	57.2	66.5	102.1	6.6	19.3	27.4	19.1 mm	25.7	15.5	20.6	5.6
042-048	in.	22.5	26.2	44.2	2.6	7.6	10.8	3/4 in.	10.1	6.1	8.1	2.2
	cm.	57.2	66.5	112.3	6.6	19.3	27.4	19.1 mm	25.7	15.5	20.6	5.6
060	in.	25.5	31.2	44.2	2.6	7.6	10.8	1 in.	10.1	6.1	8.1	2.2
	cm.	64.8	79.2	112.3	6.6	19.3	27.4	25.4 mm	25.7	15.5	20.6	5.6
070	in.	25.5	31.2	48.2	2.6	7.6	10.8	1 in.	10.1	6.1	8.1	2.2
	cm.	64.8	79.2	122.4	6.6	19.3	27.4	25.4 mm	25.7	15.5	20.6	5.6

Vertical Models	Discharge Connection duct flange installed (30.10 in)					**Return Connection using deluxe filter rack (30.10 in)				
	N	P	Q	R	S	T	U	V	W	
	Supply Width	Supply Depth					Return Depth	Return Height		
006-012	in.	10.0	10.0	4.6	4.4	7.8	2.4	14.3	10.1	2.0
	cm.	25.4	25.4	11.7	11.2	19.8	6.1	36.3	25.7	5.1
015-018	in.	14.0	14.0	4.1	4.3	7.7	2.1	18.1	14.0	2.0
	cm.	35.6	35.6	10.4	10.9	19.6	5.3	46.0	35.6	5.1
024-030	in.	14.0	14.0	4.1	4.3	7.7	2.1	18.1	20.0	2.0
	cm.	35.6	35.6	10.4	10.9	19.6	5.3	46.0	50.8	5.1
036	in.	14.0	14.0	6.1	4.5	7.7	2.1	22.1	22.1	2.0
	cm.	35.6	35.6	15.5	11.4	19.6	5.3	56.1	56.1	5.1
042-048	in.	18.0	18.0	4.1	3.9	3.9	2.1	22.1	26.1	2.0
	cm.	45.7	45.7	10.4	9.9	9.9	5.3	56.1	66.3	5.1
060	in.	18.0	18.0	6.6	4.6	6.3	1.6	28.1	26.0	2.0
	cm.	45.7	45.7	16.8	11.7	16.0	4.1	71.4	66.0	5.1
070	in.	18.0	18.0	6.6	4.6	6.3	1.6	28.1	30.0	2.0
	cm.	45.7	45.7	16.8	11.7	16.0	4.1	71.4	76.2	5.1

Condensate is 3/4 in. PVC female glue socket and is switchable from side to front.

* Discharge flange is field installed and extends 1 in. (25.4 mm) from top of cabinet.

** Vertical units shipped with standard 2 in. (field adjustable to 1 in.) open application filter rail extending 2.2 in. from the unit and is not suitable for duct connection. For ductable return connection applications, order the 2 in. (field adjustable to 1 in.) duct collar/ filter rack which extends to 3.25 in. from the unit and is suitable for duct connections.

09/26/12

Vertical Disconnect

When using disconnect, do not use dimension L from the standard vertical dimensional data. Use dimension LL from the vertical disconnect dimensional data.

Vertical Models	LL
015-018	15.8 [40.1]
024-030	18.8 [47.8]
036	15.3 [38.9]
042-048	13.8 [35.1]
060	14.3 [36.3]
070	14.3 [36.3]

Dimensions in inches [cm]

* Models 006-012 - Externally Mounted Disconnect

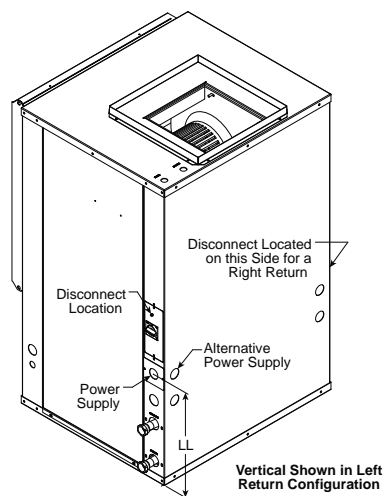

Vertical Shown in Left Return Configuration

Horizontal Dimensional Data

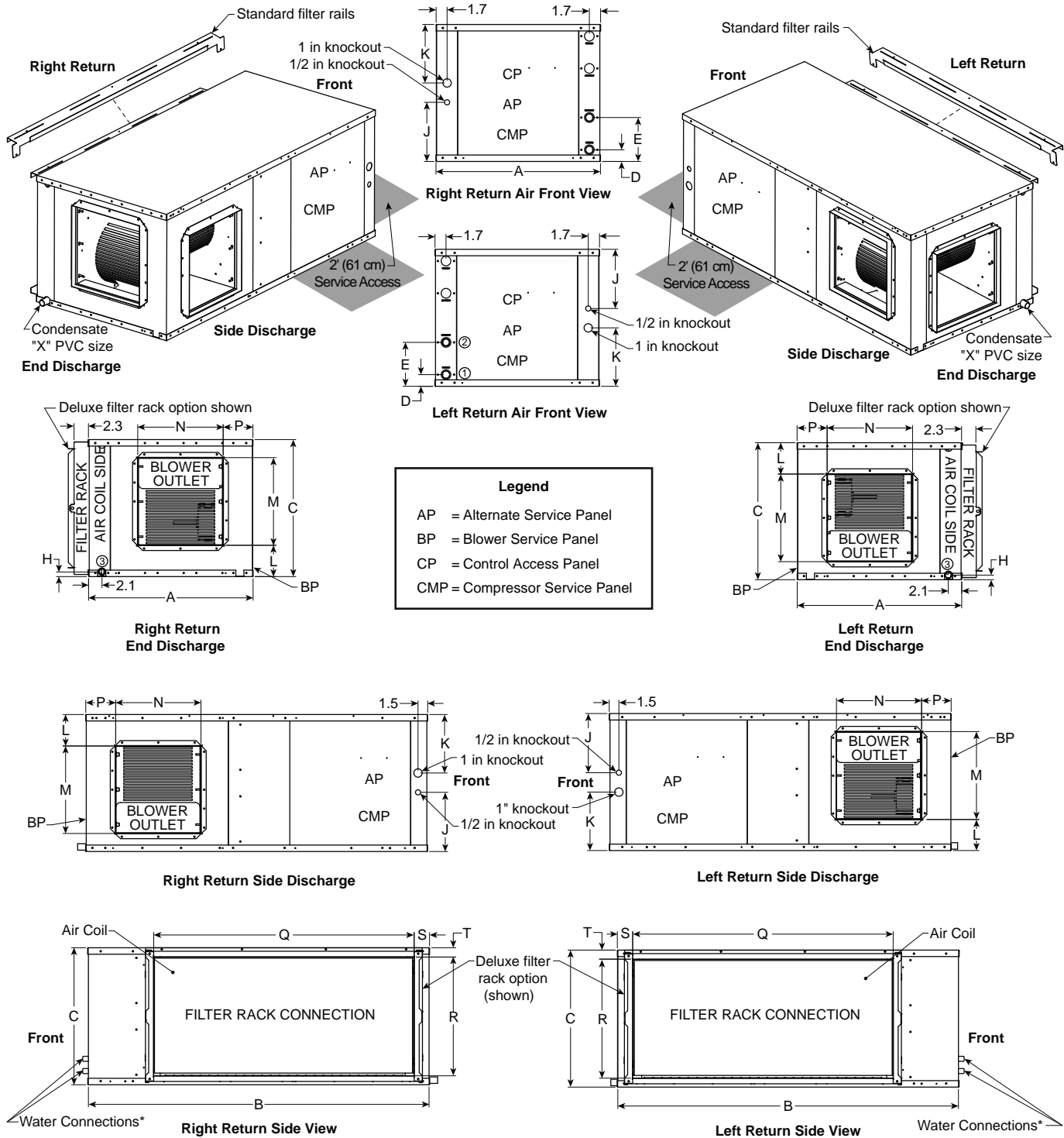

NOTE: * Water connections protrude approximately 1.5 in. from cabinet.

Horizontal Dimensional Data cont.

Horizontal Models		Overall Cabinet			Water Connections				Electrical Knockouts	
		A	B	C	1	2	3	Loop	J	K
		Width	Depth	Height*	D	E	H		1/2 in. cond	1 in. cond
006-012**	in.	19.2	35.0	12.1	1.8	4.8	3.6	1/2 in.	7.4	7.5
	cm.	48.8	88.9	30.7	4.6	12.2	9.1	12.70 mm	18.8	19.1
015-018	in.	22.5	35.0	17.2	1.8	6.8	0.8	3/4 in.	7.1	7.1
	cm.	57.2	88.9	43.7	4.6	17.3	2.0	19.05 mm	18.0	18.0
024-030	in.	22.5	42.0	17.2	1.8	6.8	0.8	3/4 in.	7.1	7.1
	cm.	57.2	106.7	43.7	4.6	17.3	2.0	19.05 mm	18.0	18.0
036	in.	22.5	42.0	19.2	1.8	6.8	0.8	3/4 in.	9.2	7.1
	cm.	57.2	106.7	48.8	4.6	17.3	2.0	19.05 mm	23.4	18.0
042-048	in.	22.5	45.0	19.2	1.8	6.8	0.8	3/4 in.	9.2	7.1
	cm.	57.2	114.3	48.8	4.6	17.3	2.0	19.05 mm	23.4	18.0
060	in.	25.5	48.0	21.2	1.8	6.8	0.8	1 in.	9.2	9.1
	cm.	64.8	121.9	53.8	4.6	17.3	2.0	25.4 mm	23.4	23.1
070	in.	25.5	53.0	21.2	1.8	6.8	0.8	1 in.	9.2	9.1
	cm.	64.8	134.6	53.8	4.6	17.3	2.0	25.4 mm	23.4	23.1

Horizontal Models		Discharge Connection duct flange installed (30.10 in)				Return Connection using deluxe filter rack option (30.10 in)				PVC Size
		L	M	N	P	Q	R	S	T	X
		Supply Width	Supply Depth		Return Depth	Return Height				
006-012**	in.	2.3	8.0	10.0	2.7	22.5	9.4	2.4	1.4	1/2 in.
	cm.	5.8	20.3	25.4	6.9	57.2	23.9	6.1	3.6	1.3
015-018	in.	5.7	10.5	9.4	4.9	16.4	14.5	2.0	1.4	3/4 in.
	cm.	14.5	26.7	23.9	12.4	41.7	36.8	5.1	3.6	1.9
024-030	in.	5.7	10.5	9.4	4.9	23.4	14.5	2.0	1.4	3/4 in.
	cm.	14.5	26.7	23.9	12.4	59.4	36.8	5.1	3.6	1.9
036	in.	6.7	10.5	9.4	4.9	27.4	16.5	2.0	1.4	3/4 in.
	cm.	17.0	26.7	23.9	12.4	69.6	41.9	5.1	3.6	1.9
042-048	in.	4.2	13.6	13.2	2.4	30.4	16.5	2.0	1.5	3/4 in.
	cm.	10.7	34.5	33.5	6.1	77.2	41.9	5.1	3.8	1.9
060	in.	4.8	13.6	13.2	4.6	35.4	18.7	2.3	1.3	3/4 in.
	cm.	12.2	34.5	33.5	11.7	89.9	47.5	5.8	3.3	1.9
070	in.	4.8	13.6	13.2	4.6	40.4	18.5	2.3	1.4	3/4 in.
	cm.	12.2	34.5	33.5	11.7	102.6	47.0	5.8	3.6	1.9

09/26/12

Horizontal units shipped with standard 2 in. (field adjustable to 1 in.) open application filter rail extending 2.2 in. from the unit and is not suitable for duct connection. For ductable return connection applications, order the 2 in. (field adjustable to 1 in.) duct collar/ filter rack which extends to 3.25 in. from the unit and is suitable for duct connections.

** UBH006-012 offers a lifted drain pan that allows the trap to be installed without additional ceiling height required.

Horizontal Disconnect

When using disconnect, do not use dimension K from the standard horizontal dimensional data. Use dimension KK from the horizontal disconnect dimensional data.

Horizontal Models	KK
015-018	8.2 [20.8]
024-030	8.2 [20.8]
036	9.2 [23.4]
042-048	9.2 [23.4]
060	11.2 [28.4]
070	10.2 [25.9]

Dimensions in inches [cm]

* Models 006-012 - Externally Mounted Disconnect

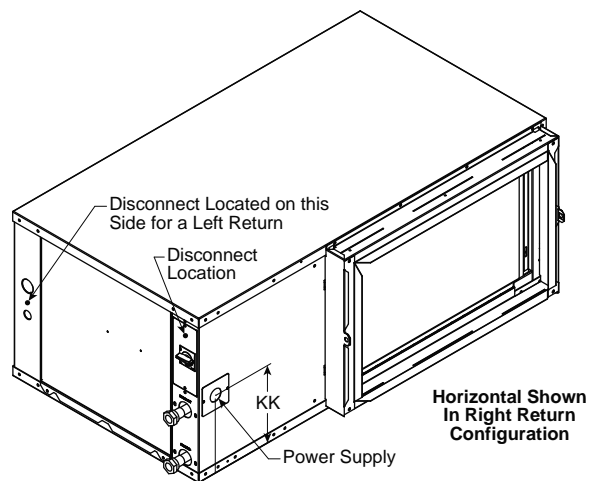

Installing Horizontal Units

Installing Horizontal Units

Horizontal units are available with side or end discharge and may be easily field converted by flipping the blower discharge panel. Horizontal units are normally suspended from a ceiling by four 3/8 in. diameter threaded rods. The rods are usually attached to the unit by hanger bracket kits furnished with each unit. Lay out the threaded rods per the dimensions below. Assemble the hangers to the unit as shown. Securely tighten the brackets to the unit using the weld nuts located on the underside of the bottom panel. When attaching the hanger rods to the bracket, a double nut is required since vibration could loosen a single nut.

NOTE: The unit should be pitched approximately 1/4 in. towards the drain in both directions to facilitate the removal of condensate.

Use only the bolts provided in the kit to attach hanger brackets. The use of longer bolts could damage internal parts. Some applications require the installation of horizontal units on an attic floor. In this case, the unit should be set in a full size secondary drain pan on top of a vibration absorbing pad. The secondary drain pan prevents possible condensate overflow or water leakage damage to the ceiling. The secondary drain pan is usually placed on a plywood base isolated from the ceiling joists by additional layers of vibration absorbing material. Insulate supply plenum and use at least one 90° elbow and flexible duct collar to reduce noise.



CAUTION: Do not use rods smaller than 3/8 in. diameter since they may not be strong enough to support the unit. The rods must be securely anchored to the ceiling.

Horizontal Unit Mounting

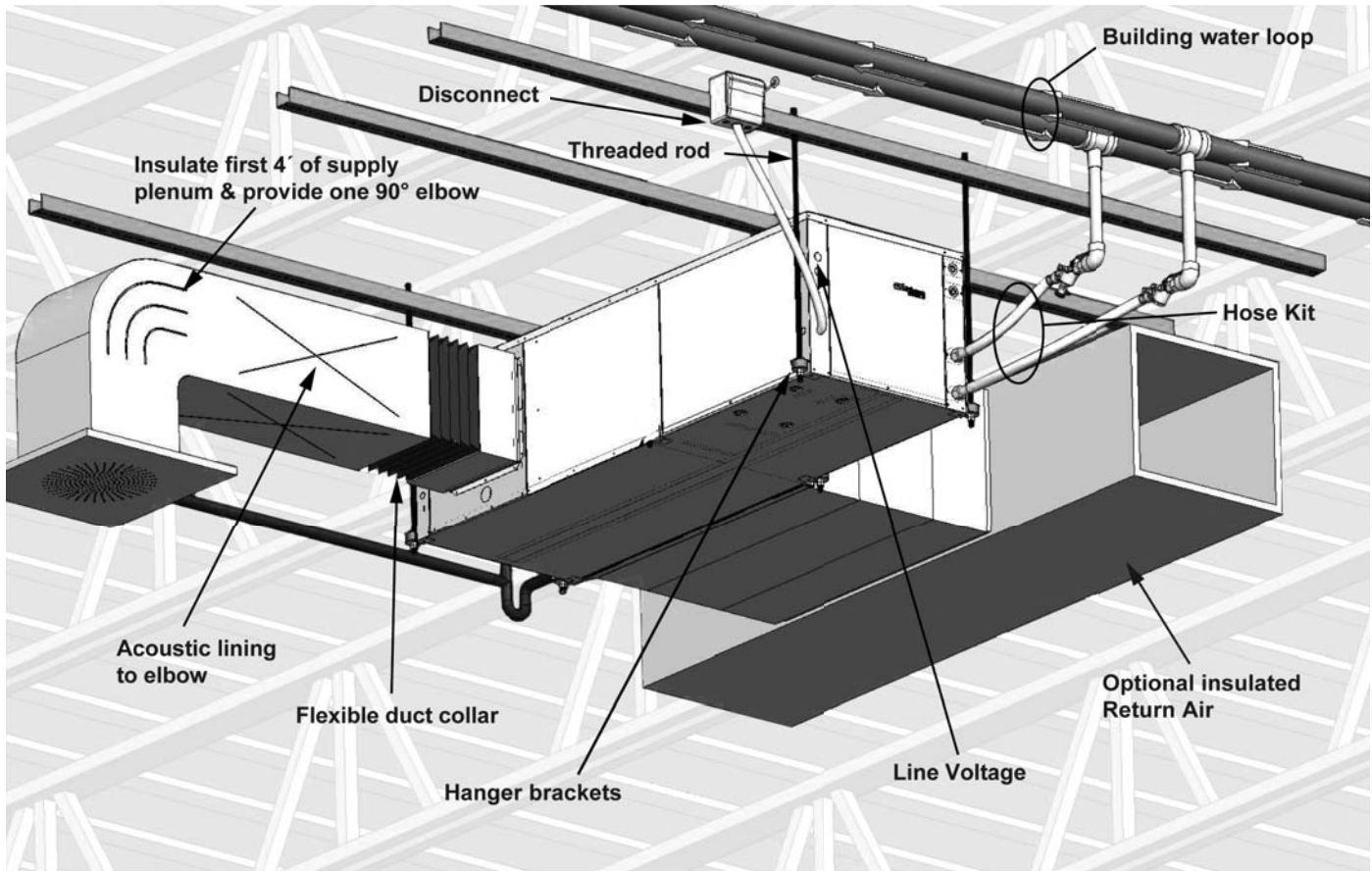

Hanger Bracket Locations

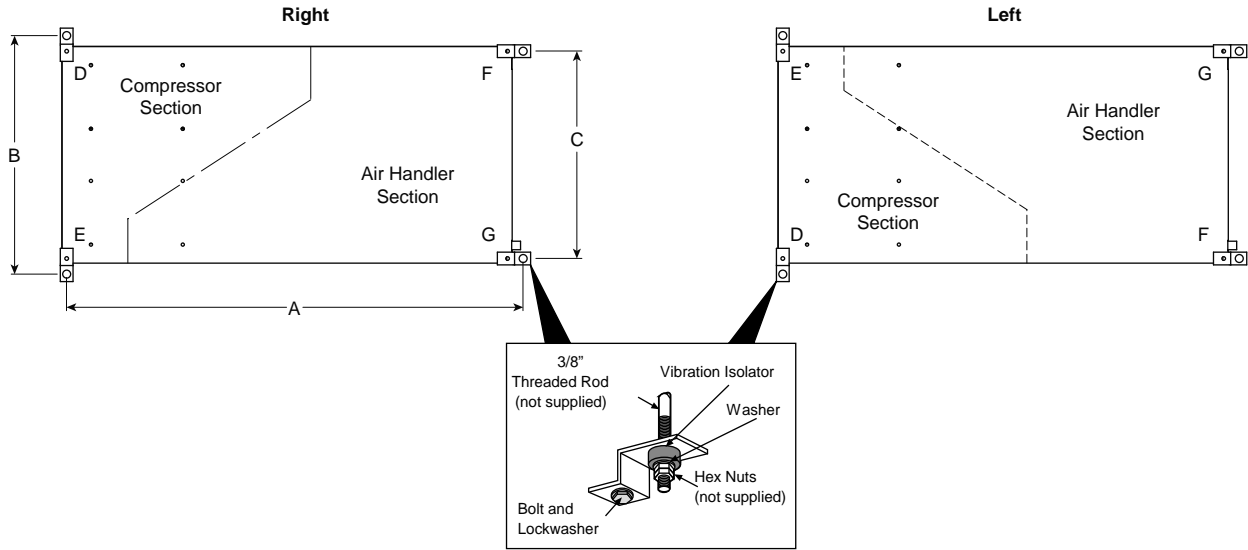

Hanger Dimensions

Model	Hanger Kit Part Number	Unit Hanger Dimensions		
		A	B	C
006-012	in.	35.8	21.8	18.1
	cm.	90.9	55.4	46.0
015-018	in.	35.8	25.1	21.4
	cm.	90.9	63.8	54.4
024-030	in.	42.8	25.1	21.4
	cm.	108.6	63.8	54.4
036	in.	42.8	25.1	21.4
	cm.	108.7	63.8	54.4
042-048	in.	45.8	25.1	21.4
	cm.	116.3	63.8	54.4
060	in.	48.8	28.1	24.4
	cm.	124.0	71.4	62.0
070	in.	53.8	28.1	24.4
	cm.	136.7	71.4	62.0

09/26/12

Weight Distribution

Model	Vertical Shipping Weight	Horizontal Shipping Weight	Horizontal Weight Distribution				
			Front		Back		
			D	E	F	G	
006-012	lb.	111	112	44	21	19	28
	kg	50	51	20	10	9	12
015-018	lb.	171	176	67	32	32	45
	kg	78	80	30	15	15	20
024	lb.	245	242	85	47	45	65
	kg	111	110	39	21	20	29
030	lb.	245	242	85	47	45	65
	kg	111	110	39	21	20	29
036	lb.	267	265	95	60	50	60
	kg	121	120	43	27	23	27
042	lb.	305	310	105	68	60	77
	kg	138	141	48	31	27	35
048	lb.	305	310	105	68	60	77
	kg	138	141	48	31	27	35
060	lb.	344	350	115	77	68	90
	kg	156	159	52	35	31	41
070	lb.	357	378	130	80	73	95
	kg	162	171	59	36	33	43

10/03/12

Duct System

An air outlet collar is provided on vertical top flow units and all horizontal units to facilitate a duct connection. A flexible connector is recommended for discharge and return air duct connections on metal duct systems. Uninsulated duct should be insulated with a minimum of 1-inch duct insulation. Application of the unit to uninsulated ductwork in an unconditioned space is not recommended as the unit's performance will be adversely affected.

If the unit is connected to existing ductwork, check the duct system to ensure that it has the capacity to accommodate the air required for the unit application. If the duct is too small, as in the replacement of heating only systems, larger

ductwork should be installed. All existing ductwork should be checked for leaks and repaired if necessary.

The duct system should be sized to handle the design airflow quietly and efficiently. To maximize sound attenuation of the unit blower, the supply and return plenums should include an internal duct liner of fiberglass or constructed of ductboard for the first few feet. On systems employing a sheet metal duct system, canvas connectors should be used between the unit and the ductwork. If air noise or excessive airflow is a problem, the blower speed can be changed.

Water Piping

The proper water flow must be provided to each unit whenever the unit operates. To assure proper flow, use pressure/temperature ports to determine the flow rate. These ports should be located at the supply and return water connections on the unit. The proper flow rate cannot be accurately set without measuring the water pressure drop through the refrigerant-to-water heat exchanger.

All source water connections on commercial units are fittings that accept a male pipe thread (MPT). Insert the connectors by hand, then tighten the fitting with a wrench to provide a leakproof joint. When connecting to an open loop (groundwater) system, thread any copper MPT fitting into the connector and tighten in the same manner as described above.

Water Quality

In ground water situations where scaling could be heavy or where biological growth such as iron bacteria will be present, a closed loop system is recommended. The heat exchanger coils in ground water systems may, over a period of time, lose heat exchange capabilities due to a buildup of mineral deposits inside. These can be cleaned, but only by a qualified service mechanic, as special solutions and pumping equipment are required. Hot water generator coils can likewise become scaled and possibly plugged. In areas

with extremely hard water, the owner should be informed that the heat exchanger may require occasional flushing. Failure to adhere to the guidelines in the water quality table could result in loss of warranty.

Units with cupronickel heat exchangers are recommended for open loop applications due to the increased resistance to build-up and corrosion, along with reduced wear caused by acid cleaning.

Material		Copper	90/10 Cupronickel	316 Stainless Steel
pH	Acidity/Alkalinity	7 - 9	7 - 9	7 - 9
Scaling	Calcium and Magnesium Carbonate	(Total Hardness) less than 350 ppm	(Total Hardness) less than 350 ppm	(Total Hardness) less than 350 ppm
Corrosion	Hydrogen Sulfide	Less than 0.5 ppm (rotten egg smell appears at 0.5 ppm)	10 - 50 ppm	Less than 1 ppm
	Sulfates	Less than 125 ppm	Less than 125 ppm	Less than 200 ppm
	Chlorine	Less than 0.5 ppm	Less than 0.5 ppm	Less than 0.5 ppm
	Chlorides	Less than 20 ppm	Less than 125 ppm	Less than 300 ppm
	Carbon Dioxide	Less than 50 ppm	10 - 50 ppm	10 - 50 ppm
	Ammonia	Less than 2 ppm	Less than 2 ppm	Less than 20 ppm
	Ammonia Chloride	Less than 0.5 ppm	Less than 0.5 ppm	Less than 0.5 ppm
	Ammonia Nitrate	Less than 0.5 ppm	Less than 0.5 ppm	Less than 0.5 ppm
	Ammonia Hydroxide	Less than 0.5 ppm	Less than 0.5 ppm	Less than 0.5 ppm
	Ammonia Sulfate	Less than 0.5 ppm	Less than 0.5 ppm	Less than 0.5 ppm
	Total Dissolved Solids (TDS)	Less than 1000 ppm	1000 - 1500 ppm	1000 - 1500 ppm
	LSI Index	+0.5 to -0.5	+0.5 to -0.5	+0.5 to -0.5
Iron Fouling (Biological Growth)	Iron, FE ²⁺ (Ferrous) Bacterial Iron Potential	< 0.2 ppm	< 0.2 ppm	< 0.2 ppm
	Iron Oxide	Less than 1 ppm, above this level deposition will occur	Less than 1 ppm, above this level deposition will occur	Less than 1 ppm, above this level deposition will occur
Erosion	Suspended Solids	Less than 10 ppm and filtered for max. of 600 micron size	Less than 10 ppm and filtered for max. of 600 micron size	Less than 10 ppm and filtered for max. of 600 micron size
	Threshold Velocity (Fresh Water)	< 6 ft/sec	< 6 ft/sec	< 6 ft/sec

NOTES: Grains = ppm divided by 17 mg/L is equivalent to ppm

2/22/12

Condensate Drain

On vertical units, the internal condensate drain assembly consists of a drain tube which is connected to the drain pan, a 3/4 in. PVC female adapter and a flexible connecting hose. The female adapter may exit either the front or the side of the cabinet. The adapter should be glued to the field-installed PVC condensate piping. On vertical units, a condensate hose is inside all cabinets as a trapping loop; therefore, an external trap is not necessary.

On horizontal units, a PVC stub or stainless steel tube is provided for condensate drain piping connection. An external trap is required (see below). If a vent is necessary, an open stand pipe may be applied to a tee in the field-installed condensate piping.

NOTE: All units equipped with electronic condensate overflow protection.

Horizontal Drain Connection (Composite Drain Pan)

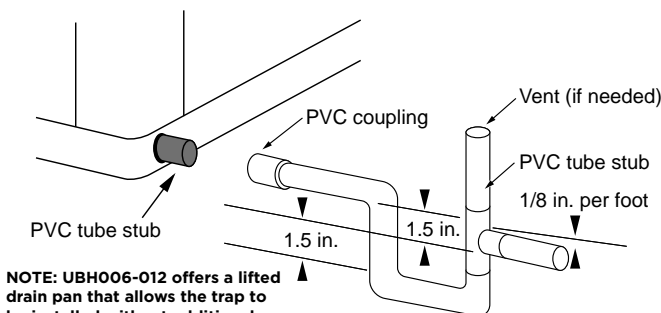

NOTE: UBH006-012 offers a lifted drain pan that allows the trap to be installed without additional ceiling height required.

Unit Pitch for Drain

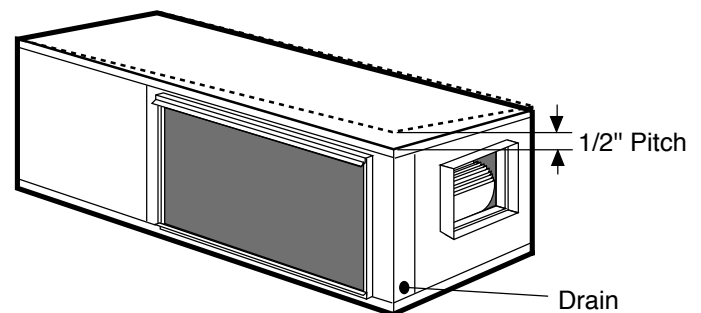

System Cleaning and Flushing

Cleaning and Flushing

Prior to start up of any heat pump, the water circulating system must be cleaned and flushed of all dirt and debris.

If the system is equipped with water shutoff valves, the supply and return runouts must be connected together at each unit location (This will prevent the introduction of dirt into the unit, see Flushing with Water Shutoff Valve Equipped Systems illustration). The system should be filled at the water make-up connection with all air vents open. After filling, vents should be closed.

Flushing with Water Shutoff Valve Equipped Systems

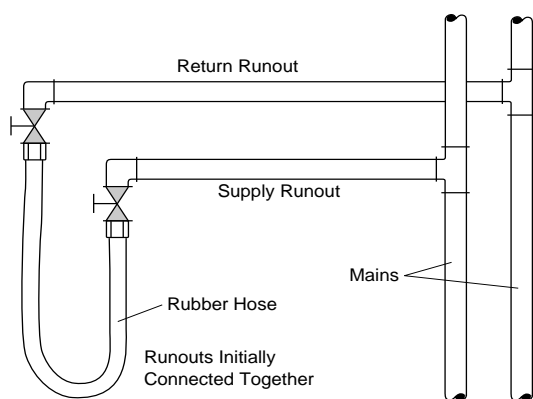

The contractor should start the main circulator with the pressure reducing valve makeup open. Vents should be checked in sequence to bleed off any trapped air and to verify circulation through all components of the system.

As water circulates through the system, the contractor should check and repair any leaks found in the piping system. Drain(s) at the lowest point(s) in the system should be opened for initial flush and blowdown, making sure water fill valves are set at the same rate. Check the pressure gauge at the pump suction and manually adjust the make-up water valve to hold the same positive pressure both before and after opening the drain valves. Flushing should continue for at least two hours, or longer if required, until drain water is clean and clear.

The supplemental heater and/or circulator pump, if used, should be shut off. All drains and vents should be opened to completely drain the system. Short-circuited supply and return runouts should now be connected to the unit supply and return connections.

Refill the system with clean water. Test the system water for acidity and treat as required to leave the water slightly alkaline (pH 7.5 to 8.5). The specified percentage of antifreeze may also be added at this time. Use commercial grade antifreeze designed for HVAC systems only. Environol™ brand antifreeze is recommended.

Once the system has been filled with clean water and antifreeze (if used), precautions should be taken to protect the system from dirty water conditions. Dirty water will result in system-wide degradation of performance, and solids may clog valves, strainers, flow regulators, etc. Additionally, the heat exchanger may become clogged which reduces compressor service life and can cause premature unit failure.

In boiler/tower application, set the loop control panel set points to desired temperatures. Supply power to all motors and start the circulating pumps. After full flow has been established through all components including the heat rejector (regardless of season), air vented and loop temperatures stabilized, each of the units will be ready for check, test and start up and for air and water balancing.

Ground Source Loop System Checkout

Once piping is completed between the unit pumping system and ground loop, final purging and charging of the loop is needed. A high pressure pump is needed to achieve adequate flow velocity in the loop to purge air and dirt particles from the loop itself. Antifreeze solution is used in most areas to prevent freezing. Flush the system adequately to remove as much air as possible; then pressurize the loop to a static pressure of 40-50 PSI (summer) or 50-75 PSI (winter). This is normally adequate for good system operation. Loop static pressure may decrease soon after initial installation, due to pipe expansion and loop temperature change. Running the unit for at least 30 minutes after the system has been completely purged of air will allow for the “break-in” period. It may be necessary to adjust static loop pressure (by adding water) after the unit has run for the first time. Loop static pressure will also fluctuate with the seasons. Pressures will be higher in the winter months than during the cooling season. This fluctuation is normal and should be considered when charging the system initially.

Ensure the pump provides adequate flow through the unit by checking pressure drop across the heat exchanger. Usually 2.25-3.0 gpm of flow per ton of cooling capacity is recommended in earth loop applications.

Open Loop Ground Water Systems

Typical open loop piping is shown below. Always maintain water pressure in the heat exchanger by placing water control valves at the outlet of the unit to prevent mineral precipitation. Use a closed, bladder-type expansion tank to minimize mineral formation due to air exposure. Insure proper water flow through the unit by checking pressure drop across the heat exchanger and comparing it to the figures in unit capacity data tables in the specification catalog. 1.5-2 gpm of flow per ton of cooling capacity is recommended in open loop applications. Due to only minor differences in flow rate from low to high, only one solenoid valve should be used. The valve should be sized for full flow.

Discharge water from the unit is not contaminated in any manner and can be disposed of in various ways, depending on local codes, i.e. recharge well, storm sewer, drain field, adjacent stream or pond, etc. Most local codes forbid the use of sanitary sewer for disposal. Consult your local building and zoning departments to assure compliance in your area.

Open System - Groundwater Application

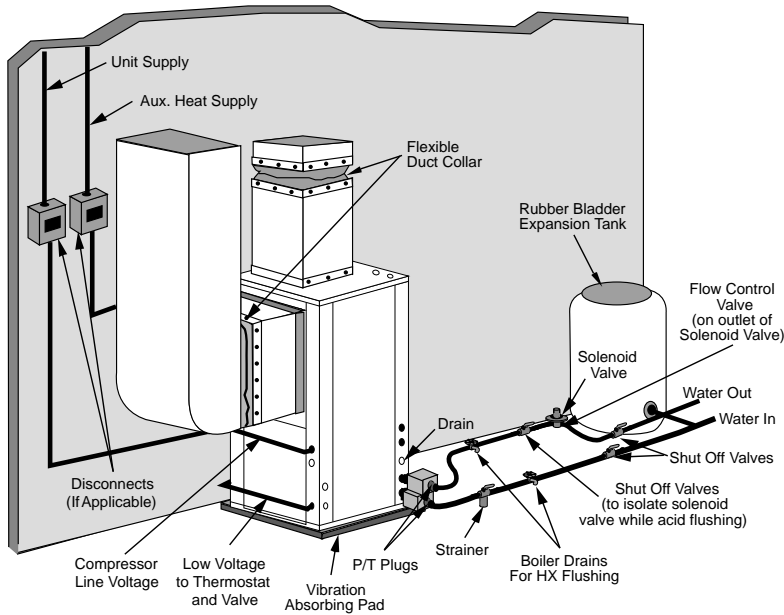

Freeze Detection

For Aurora Base Control, set SW2-1, FP1, on the printed circuit board for applications using a closed loop antifreeze solution to 15°F [-9.4°C]. On applications using an open loop/ground water system (or closed loop no antifreeze), set this dip switch to 30°F [-1.1°C], the factory default setting. (Refer to the Dip Switch Field Selection table).

Electrical Connections

General

Be sure the available power is the same voltage and phase as that shown on the unit serial plate. Line and low voltage wiring must be done in accordance with local codes or the National Electric Code, whichever is applicable.

Power Connection

Connect the incoming line voltage wires to L1 and L2 of the contactor for single-phase unit. Consult the Electrical Data tables for correct fuse sizes.

208 Volt Operation

All Versatec Base Series 208/230 units are factory wired for 230 volt operation. For 208 volt operation, the red and blue transformer wires must be switched on terminal strip PS.



CAUTION: When installing a unit with a variable speed ECM blower motor in 460/60/3 voltage, a neutral wire is required to allow proper unit operation.

Aurora Base Control Box

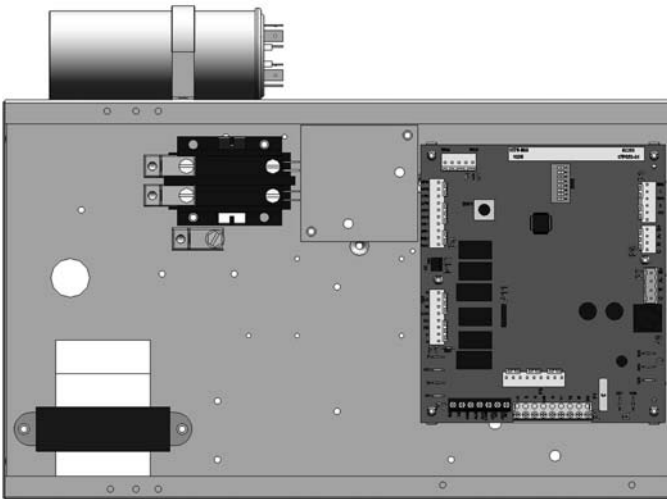

Electrical Data

PSC Motor

Model	Rated Voltage	Voltage Min/Max	Compressor			Blower Motor FLA	Total Unit FLA	Min Circ Amp	Max Fuse/HACR
			MCC	RLA	LRA				
006	115/60/1	104/127	9.5	6.1	29.0	1.5	7.6	9.1	15
	208-230/60/1	198/253	4.7	3.0	15.0	0.6	3.6	4.4	10/15
	265/60/1	238/292	4.2	2.7	11.0	0.6	3.3	4.0	10/15
009	115/60/1	104/127	12.5	8.0	50.0	1.5	9.5	11.5	15
	208-230/60/1	198/253	6.4	4.1	21.0	0.6	4.7	5.7	10/15
	265/60/1	238/292	6.7	4.3	22.0	0.6	4.9	6.0	10/15
012	115/60/1	104/127	14.8	9.5	50.0	1.5	11.0	13.4	20
	208-230/60/1	198/253	7.7	4.9	25.0	0.6	5.5	6.7	10/15
	265/60/1	238/292	7.0	4.5	22.0	0.6	5.1	6.2	10/15
015	208-230/60/1	198/253	9.2	5.9	29.0	1.1	7.8	9.5	15
	265/60/1	238/292	7.8	5.0	28.0	1.0	6.6	8.0	10/15
018	208-230/60/1	198/253	10.4	6.7	33.5	1.1	7.8	9.5	15
	265/60/1	238/292	8.7	5.6	28.0	1.0	6.6	8.0	10/15
024	208-230/60/1	198/253	13.0	7.4	43.0	1.2	8.6	10.5	15
	265/60/1	238/292	12.6	6.7	46.0	1.1	7.8	9.5	15
	208-230/60/3	187/253	13.0	5.9	63.0	1.2	7.1	8.6	10/15
	460/60/3	414/506	6.0	2.9	30.0	0.6	3.5	4.2	10/15
030	208-230/60/1	198/253	17.5	9.4	54.0	1.5	10.9	13.3	20
	265/60/1	238/292	14.0	8.0	46.0	1.5	9.5	11.5	15
	208-230/60/3	187/253	13.5	6.6	63.0	1.5	8.1	9.8	15
	460/60/3	414/506	6.4	3.2	30.0	1.0	4.2	5.0	10/15
036	208-230/60/1	198/253	20.5	11.6	74.0	2.2	13.8	16.7	25
	265/60/1	238/292	17.7	9.9	67.0	1.1	11.0	13.5	20
	208-230/60/3	187/253	13.5	7.4	68.0	2.2	9.6	11.5	15
	460/60/3	414/506	7.1	3.8	34.0	1.1	4.9	5.9	10/15
042	208-230/60/1	198/253	25.0	13.0	88.0	3.5	16.5	19.8	30
	208-230/60/3	187/253	14.5	8.6	68.0	3.5	12.1	14.3	20
	460/60/3	342/506	7.7	4.2	34.0	1.8	6.0	7.1	10/15
	575/60/3	517/633	6.0	3.5	28.0	1.4	4.9	5.8	10/15
048	208-230/60/1	198/253	24.5	15.7	84.0	3.5	19.2	23.1	35
	208-230/60/3	187/253	17.5	11.0	88.0	3.5	14.5	17.3	25
	460/60/3	342/506	8.0	5.6	44.0	1.8	7.4	8.8	10/15
	575/60/3	517/633	7.0	4.4	36.0	1.9	5.8	6.9	10/15
060	208-230/60/1	198/253	33.0	21.1	105.0	5.9	27.0	32.3	50
	208-230/60/3	187/253	22.0	12.9	88.0	5.9	18.8	22.0	30
	460/60/3	342/506	12.0	6.7	55.0	3.0	9.7	11.4	15
	575/60/3	517/633	7.5	5.1	36.0	1.9	7.0	8.3	10/15
070	208-230/60/1	198/253	36.0	23.0	130.0	5.9	28.9	34.7	50
	208-230/60/3	187/253	24.6	14.3	110.0	5.9	20.2	23.8	35
	460/60/3	342/506	11.5	7.1	55.0	3.0	10.1	11.9	15
	575/60/3	517/633	8.7	5.6	43.0	1.9	7.5	8.9	10/15

HACR circuit breaker in USA only

10/03/12

Electrical Data cont.

5-Speed ECM Motor

Model	Rated Voltage	Voltage Min/Max	Compressor			Blower Motor FLA	Total Unit FLA	Min Circ Amp	Max Fuse/HACR
			MCC	RLA	LRA				
015	208-230/60/1	198/253	9.2	5.9	29.0	4.1	10.0	11.5	15
	265/60/1	238/292	7.8	5.0	28.0	3.6	8.6	9.8	10/15
018	208-230/60/1	198/253	10.4	6.7	33.5	4.1	10.8	12.5	15
	265/60/1	238/292	8.7	5.6	28.0	3.6	9.2	10.6	10/15
024	208-230/60/1	198/253	13.0	7.4	43.0	4.1	11.5	13.4	20
	265/60/1	238/292	12.6	6.7	46.0	3.6	10.3	12.0	15
	208-230/60/3	187/253	13.0	5.9	63.0	4.1	10.0	11.5	15
	460/60/3	414/506	6.0	2.9	30.0	2.1	5.0	5.7	10/15
030	208-230/60/1	198/253	17.5	9.4	54.0	4.1	13.5	15.9	25
	265/60/1	238/292	14.0	8.0	46.0	3.6	11.6	13.6	20
	208-230/60/3	187/253	13.5	6.6	63.0	4.1	10.7	12.4	15
	460/60/3	414/506	6.4	3.2	30.0	2.1	5.3	6.1	10/15
036	208-230/60/1	198/253	20.5	11.6	74.0	4.1	15.7	18.6	30
	265/60/1	238/292	17.7	9.9	67.0	3.6	13.5	16.0	25
	208-230/60/3	187/253	13.5	7.4	68.0	4.1	11.5	13.4	20
	460/60/3	414/506	7.1	3.8	34.0	2.1	5.9	6.9	10/15
042	208-230/60/1	198/253	25.0	13.0	88.0	7.6	20.6	23.9	35
	208-230/60/3	187/253	14.5	8.6	68.0	7.6	16.2	18.4	25
	460/60/3	414/506	7.7	4.2	34.0	4.0	8.2	9.3	10/15
048	208-230/60/1	198/253	24.5	15.7	84.0	7.6	23.3	27.2	40
	208-230/60/3	187/253	17.5	11.0	88.0	7.6	18.6	21.4	30
	460/60/3	414/506	8.0	5.6	44.0	4.0	9.6	11.0	15
060	208-230/60/1	198/253	33.0	21.1	105.0	7.6	28.7	34.0	50
	208-230/60/3	187/253	22.0	12.9	88.0	7.6	20.5	23.7	35
	460/60/3	414/506	12.0	6.7	55.0	4.0	10.7	12.4	15
070	208-230/60/1	198/253	36.0	23.0	130.0	7.6	30.6	36.4	50
	208-230/60/3	187/253	24.6	14.3	110.0	7.6	21.9	25.5	35
	460/60/3	414/506	11.5	7.1	55.0	4.0	11.1	12.9	20

HACR circuit breaker in USA only

10/03/12

Electrical Data cont.

Variable Speed ECM Motor

Model	Rated Voltage	Voltage Min/Max	Compressor			Blower Motor FLA	Total Unit FLA	Min Circ Amp	Max Fuse/HACR
			MCC	RLA	LRA				
015	208-230/60/1	198/253	9.2	5.9	29.0	4.0	9.9	11.4	15
	265/60/1	238/292	7.8	5.0	28.0	4.1	9.1	10.3	15
018	208-230/60/1	198/253	10.4	6.7	33.5	4.0	10.7	12.4	15
	265/60/1	238/292	8.7	5.6	28.0	4.1	9.7	11.1	15
024	208-230/60/1	198/253	13.0	7.4	43.0	4.0	11.4	13.3	20
	265/60/1	238/292	12.6	6.7	46.0	4.1	10.8	12.5	20
	208-230/60/3	187/253	13.0	5.9	63.0	4.0	9.9	11.4	15
	460/60/3	414/506	6.0	2.9	30.0	4.1	7.0	7.7	10/15
030	208-230/60/1	198/253	17.5	9.4	54.0	4.0	13.4	15.8	25
	265/60/1	238/292	14.0	8.0	46.0	4.1	12.1	14.1	20
	208-230/60/3	187/253	13.5	6.6	63.0	4.0	10.6	12.3	20
	460/60/3	414/506	6.4	3.2	30.0	4.1	7.3	8.1	10/15
036	208-230/60/1	198/253	20.5	11.6	74.0	4.0	15.6	18.5	30
	265/60/1	238/292	17.7	9.9	67.0	4.1	14.0	16.5	25
	208-230/60/3	187/253	13.5	7.4	68.0	4.0	11.4	13.3	20
	460/60/3	414/506	7.1	3.8	34.0	4.1	7.9	8.9	15
042	208-230/60/1	198/253	25.0	13.0	88.0	4.0	17.0	20.3	35
	208-230/60/3	187/253	14.5	8.6	68.0	4.0	12.6	14.8	25
	460/60/3	414/506	7.7	4.2	34.0	4.1	8.3	9.4	15
048	208-230/60/1	198/253	24.5	15.7	84.0	4.0	19.7	23.6	40
	208-230/60/3	187/253	17.5	11.0	88.0	4.0	15.0	17.8	30
	460/60/3	414/506	8.0	5.6	44.0	4.1	9.7	11.1	15
060	208-230/60/1	198/253	33.0	21.1	105.0	7.0	28.1	33.4	55
	208-230/60/3	187/253	22.0	12.9	88.0	7.0	19.9	23.1	35
	460/60/3	414/506	12.0	6.7	55.0	6.9	13.6	15.3	25
070	208-230/60/1	198/253	36.0	23.0	130.0	7.0	30.0	35.8	60
	208-230/60/3	187/253	24.6	14.3	110.0	7.0	21.3	24.9	40
	460/60/3	414/506	11.5	7.1	55.0	6.9	14.0	15.8	25

HACR circuit breaker in USA only

10/03/12



CAUTION: When installing a unit with an variable speed ECM blower motor in 460/60/3 voltage, a neutral wire is required to allow proper unit operation.

Blower Performance Data

Standard PSC Motor

Model	Blower Spd	Blower Size	Motor HP	Airflow (cfm) at External Static Pressure (in. wg)															
				0	0.05	0.10	0.15	0.20	0.25	0.30	0.35	0.40	0.45	0.50	0.60	0.70	0.80	0.90	1.00
006	H	6 x 8	1/10	435	425	415	405	390	365	340	325	305	290	275	245	-	-	-	-
	MH			400	390	380	370	355	335	310	295	280	265	255	210	195	-	-	-
	ML*			365	355	345	335	315	300	280	270	255	240	230	195	-	-	-	-
	L			320	305	295	280	260	250	235	225	210	195	180	150	135	-	-	-
009	H	6 x 8	1/10	435	423	415	405	390	370	340	325	305	290	275	245	-	-	-	-
	MH			400	388	380	370	355	335	310	295	280	265	255	210	195	-	-	-
	ML*			365	353	345	335	315	300	280	270	255	240	230	195	-	-	-	-
	L			320	305	295	280	260	250	235	225	210	195	180	150	135	-	-	-
012	H	6 x 8	1/10	435	423	415	405	390	370	340	325	305	290	275	245	-	-	-	-
	MH			400	388	380	370	355	335	310	295	280	265	255	210	195	-	-	-
	ML*			365	353	345	335	315	300	280	270	255	240	230	195	-	-	-	-
	L			320	305	295	280	260	250	235	225	210	195	180	150	135	-	-	-
015	H	9 x 7	1/6	795	775	755	735	715	690	670	600	530	490	455	395	-	-	-	-
	M			725	710	695	675	660	640	620	560	495	465	435	375	-	-	-	-
	L			620	610	600	590	575	550	525	490	455	395	340	290	-	-	-	-
018	H	9 x 7	1/6	795	775	755	735	715	690	670	600	530	490	455	395	-	-	-	-
	M			725	710	695	675	660	640	620	560	495	465	435	375	-	-	-	-
	L			620	610	600	590	575	550	525	490	455	395	340	290	-	-	-	-
024	H	9 x 7	1/5	1035	1015	995	970	950	925	900	865	835	795	760	685	560	-	-	-
	M			880	860	845	820	805	785	765	740	720	690	665	590	530	-	-	-
	L			810	790	775	755	740	725	705	675	650	620	595	510	-	-	-	-
030	H	9 x 7	1/3	1170	1145	1130	1110	1080	1050	1030	995	965	925	890	815	700	-	-	-
	M			1040	1030	1020	1005	990	965	945	915	890	860	830	760	650	-	-	-
	L			825	820	815	810	805	795	790	775	765	735	705	655	-	-	-	-
036	H	9 x 7	1/2	1320	1295	1275	1240	1210	1185	1155	1120	1085	1045	1005	915	805	655	-	-
	M			1180	1155	1140	1125	1100	1075	1055	1020	990	955	920	840	725	590	-	-
	L			1045	1035	1025	1015	1005	985	970	945	920	890	865	795	690	-	-	-
042	H	10x10	1/2	1530	1500	1475	1445	1425	1380	1340	1290	1240	1185	1130	810	715	630	-	-
	M			1435	1415	1395	1370	1350	1325	1300	1265	1235	1180	1130	1040	755	640	-	-
	L			1160	1140	1130	1120	1100	1070	1050	1020	990	950	910	831	632	590	-	-
048	H	10 x 10	1/2	1845	1810	1775	1740	1705	1660	1615	1560	1510	1455	1405	1275	1080	-	-	-
	M			1655	1620	1585	1555	1535	1500	1465	1415	1370	1330	1290	1170	970	-	-	-
	L			1325	1315	1310	1285	1265	1245	1220	1180	1140	1115	1090	990	-	-	-	-
060	H	11 x 10	1	2345	2320	2305	2285	2250	2205	2180	2135	2090	2060	2030	1945	1850	1740	1600	1465
	M			2195	2170	2150	2125	2105	2075	2045	2005	1970	1940	1915	1845	1770	1630	1500	-
	L			2045	2030	2020	1995	1980	1950	1925	1890	1855	1825	1800	1750	1640	1535	1395	-
070	H	11 x 10	1	2505	2475	2450	2410	2385	2365	2340	2305	2275	2250	2230	2170	2070	1975	1880	1765
	M			2290	2265	2250	2230	2200	2170	2150	2135	2125	2105	2085	2015	1950	1865	1785	1680
	L			2115	2100	2085	2060	2040	2020	2005	1990	1975	1950	1930	1875	1805	1720	1655	1510

10/03/12

Factory settings are in Bold

Airflow values are with dry coil and standard filter

For wet coil performance first calculate the face velocity of the air coil (Face Velocity [fpm] = Airflow [cfm] / Face Area [sq ft]).

Then for velocities of 200 fpm reduce the static capability by 0.03 in. wg, 300 fpm by 0.08 in. wg, 400 fpm by 0.12 in. wg. and 500 fpm by 0.16 in. wg.

* Setting for 265V operation.

Setting Blower Speed - PSC



CAUTION: Disconnect all power before performing this operation.

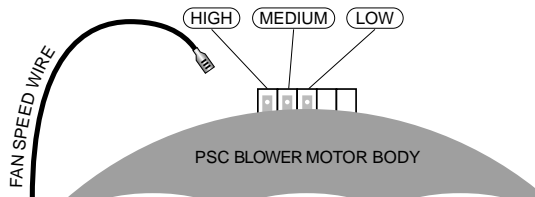

Blower Performance Data cont.

5-Speed ECM Motor

Model	Motor Spd	Motor Tap	Blower Size	Motor HP	Airflow (cfm) at External Static Pressure (in. wg)															
					0	0.05	0.10	0.15	0.20	0.25	0.30	0.35	0.40	0.45	0.50	0.60	0.70	0.80	0.90	1.00
015	High	5	9 x 7	1/2	915	895	880	865	850	830	815	805	795	775	750	730	695	640	-	-
	Med High	4			805	785	765	750	740	725	705	685	665	655	635	605	535	-	-	-
	Med	3			725	715	700	680	660	635	615	600	585	560	535	485	-	-	-	-
	Med Low	2			695	675	650	630	610	590	575	550	525	490	455	-	-	-	-	-
	Low	1			655	600	550	530	508	490	475	435	395	350	-	-	-	-	-	-
018	High	5	9 x 7	1/2	915	895	880	865	850	830	815	805	795	775	750	730	695	640	-	-
	Med High	4			805	785	765	750	740	725	705	685	665	655	635	605	535	-	-	-
	Med	3			725	715	700	680	660	635	615	600	585	560	535	485	-	-	-	-
	Med Low	2			695	675	650	630	610	590	575	550	525	490	455	-	-	-	-	-
	Low	1			655	600	550	530	508	490	475	435	395	350	-	-	-	-	-	-
024	High	5	9 x 7	1/2	1000	983	965	950	935	923	910	900	890	873	855	800	825	-	-	-
	Med High	4			905	888	870	860	850	833	815	805	795	775	755	740	705	-	-	-
	Med	3			855	838	820	800	780	773	765	745	725	715	705	670	580	-	-	-
	Med Low	2			790	773	755	743	730	710	690	675	660	643	625	570	-	-	-	-
	Low	1			615	600	585	565	545	523	500	468	435	408	380	-	-	-	-	-
030	High	5	9 x 7	1/2	1315	1293	1270	1243	1215	1183	1150	1120	1090	1055	1020	930	845	-	-	-
	Med High	4			1145	1130	1115	1105	1095	1080	1065	1053	1040	1013	985	905	820	-	-	-
	Med	3			1020	1008	995	978	960	950	940	923	905	895	885	850	795	735	-	-
	Med Low	2			980	963	945	935	925	908	890	878	865	848	830	805	780	720	-	-
	Low	1			795	778	760	738	715	705	695	678	660	650	640	575	530	-	-	-
036	High	5	9 x 7	1/2	1405	1380	1355	1333	1310	1275	1240	1208	1175	1135	1095	1015	895	775	-	-
	Med High	4			1275	1265	1255	1245	1235	1215	1195	1168	1140	1105	1070	985	875	770	-	-
	Med	3			1180	1163	1145	1135	1125	1110	1095	1085	1075	1060	1045	975	865	750	-	-
	Med Low	2			1125	1115	1105	1090	1075	1065	1055	1040	1025	1008	990	950	855	730	-	-
	Low	1			835	823	810	793	775	758	740	723	705	690	675	640	570	-	-	-
042	High	5	11 x 10	1	1805	1793	1780	1770	1760	1740	1720	1710	1700	1688	1675	1655	1635	1590	1550	1475
	Med High	4			1695	1688	1680	1660	1640	1623	1605	1593	1580	1573	1565	1535	1505	1460	1395	1300
	Med	3			1605	1593	1580	1560	1540	1523	1505	1493	1480	1470	1460	1420	1380	1305	1205	1135
	Med Low	2			1510	1495	1480	1465	1450	1435	1420	1403	1385	1373	1360	1310	1250	1135	1055	1010
	Low	1			1340	1323	1305	1283	1260	1245	1230	1213	1195	1175	1155	1040	915	875	-	-
048	High	5	11 x 10	1	2000	1990	1980	1968	1955	1940	1925	1920	1915	1910	1905	1880	1845	1790	1655	1505
	Med High	4			1840	1833	1825	1810	1795	1785	1775	1770	1765	1755	1745	1715	1670	1620	1540	1360
	Med	3			1755	1743	1730	1718	1705	1698	1690	1683	1675	1665	1635	1600	1555	1495	1435	1300
	Med Low	2			1645	1630	1615	1605	1595	1583	1570	1560	1550	1530	1510	1475	1420	1350	1265	1180
	Low	1			1430	1413	1395	1385	1375	1358	1340	1320	1300	1275	1250	1170	1060	995	930	875
060	High	5	11 x 10	1	2455	2440	2425	2413	2400	2390	2380	2365	2350	2335	2320	2295	2245	2175	2085	2015
	Med High	4			2260	2250	2240	2223	2205	2195	2185	2168	2150	2133	2115	2085	2045	2005	1975	1930
	Med	3			2140	2123	2105	2095	2085	2065	2045	2033	2020	2005	1990	1960	1915	1870	1835	1790
	Med Low	2			2010	1995	1980	1963	1945	1935	1925	1908	1890	1873	1855	1825	1780	1745	1690	1645
	Low	1			1815	1803	1790	1775	1760	1743	1725	1705	1685	1665	1645	1600	1565	1515	1470	1410
070	High	5	11 x 10	1	2500	2495	2490	2473	2455	2438	2420	2405	2390	2363	2335	2325	2280	2215	2120	1995
	Med High	4			2300	2295	2290	2270	2250	2233	2215	2200	2185	2168	2150	2115	2080	2040	1990	1915
	Med	3			2175	2163	2150	2138	2125	2100	2075	2060	2045	2030	2015	1980	1945	1905	1860	1820
	Med Low	2			2040	2028	2015	2000	1985	1965	1945	1930	1915	1898	1880	1850	1805	1760	1725	1685
	Low	1			1850	1833	1815	1800	1785	1765	1745	1728	1710	1683	1655	1615	1580	1530	1475	1300

09/26/12

Factory settings are in **Bold**
Airflow values are with dry coil and standard 1 in. filter

5-Speed ECM Motor Connections

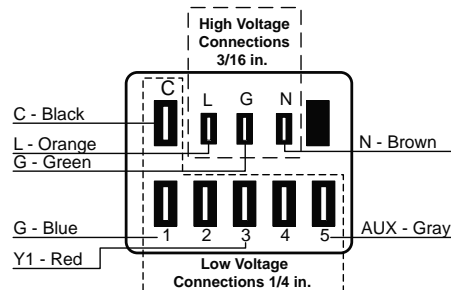

5-Speed ECM Constant Torque Motors

The 5-speed ECM is a 'Constant Torque' ECM motor and delivers air flow similar to a PSC but operates as efficiently as an variable speed ECM Motor. Because it's an ECM Motor, the 5-speed ECM can ramp slowly up or down like the variable speed ECM Motor. There are 5 possible speed taps available on the 5-speed ECM motor with #1 being the lowest airflow and #5 being the highest airflow. These speed selections are preset at the time of manufacture and are easily changed in the field if necessary.

5-Speed ECM Benefits:

- High efficiency
- Soft start
- 5 speeds with up to 4 speeds on-line
- Built in logic allows air flow to change with G, Y1, Y2 and W signals
- Super efficient low airflow continuous blower setting (G)

If more than one tap are energized at the same time, built in logic gives precedence to the highest tap number and allows air flow to change with G, Y1, Y2 and W signals. Each of those 5 speeds has a specific 'Torque' value programmed into the motor for each speed selection. As static pressure increases, airflow decreases resulting in less torque on the rotor. The motor responds only to changes in torque and adjusts its speed accordingly.

The 5-speed ECM motor is powered by line voltage but the motor speed is energized by 24VAC.

Power Connection - 3/16 in. quick connects - Line 1 (orange wire) to L, Ground (green wire) to G, Line 2 (for 208V-230V units) to N (brown wire).

Signal Connection - 1/4 in. quick connects - Common to C, 24VAC to Taps #1-5.

Applying 24VAC power between any of the motor taps 1-5 (1/4 in. quick connects) and common will signal the motor to run and regulate torque at the programmed level. The tap input voltage must be in the range 12-33VAC. The 5-speed ECM will have less variation over the operating static pressure range versus a PSC motor as well as a significant watts reduction due to the high motor efficiency.

Thermal Protection - Motor is electronically protected.

Locked Rotor Amps - If motor speed decreases below a programmed stall speed, the motor will shut down and after a delay period, the control will attempt to restart the motor.

The 5-speed ECM speed tap selections are as follows:

The blue wire should be placed on the speed tap desired for the (G) continuous blower setting – factory wired to Tap 1.

The red wire should be placed on the speed tap desired during compressor operation (Y1 signal) – factory wired to Tap 3 or 4.

The gray wire is not factory wired to the motor and is tied to the wire harness. It is field connected and can be used with 3ht/2cl thermostats or IntelliZone to deliver the required air flow for the Y2 signal.

The tan wire should be placed on the speed tap desired for auxiliary heat (W signal) – factory wired to Tap 5.

Blower Performance Data cont.

Variable Speed ECM Motor

Model	Max ESP	Blower Size	Motor hp	Air Flow Dip Switch Settings											
				1	2	3	4	5	6	7	8	9	10	11	12
015	0.50	9 x 7	1/2	300	400 L	500	600 M	700 H	800						
018	0.50	9 x 7	1/2	300	400 L	500	600 M	700 H	800						
024	0.50	9 x 7	1/2		400 L	500	600 M	700 H	800	900	1000	1100			
030	0.50	9 x 7	1/2		400	500 L	600	700 M	800	900	1000 H	1100			
036	0.50	9 x 7	1/2		400	500	600 L	700	800	900 M	1000	1100 H	1200		
042	0.50	11 x 10	1/2	500	600	700 L	875	1050	1150 M	1250	1325	1375 H	1475	1550	
048	0.50	11 x 10	1/2	500	600	700	875 L	1050	1150	1250	1325 M	1375 H	1475	1550 H	1600
060	0.75	11 x 10	1	600	800	1000 L	1300	1500 M	1750	1950 H	2100	2200	2300		
070	0.75	11 x 10	1	600	800	1000 L	1300	1500	1750 M	1950	2100 H	2200	2300		

09/26/12

Factory settings are at recommended L-M-H DIP switch locations.

Shaded regions are recommended for best performance. It is acceptable to operate outside of this area as long as the WSHP operates within the guidelines of the Operating Limits table and Correction Factor tables.

Lowest and Highest DIP switch settings are assumed to be L and H respectively.

CFM is controlled within 35% up to the maximum esp.

Max esp includes allowance for wet coil and standard filter

Setting Blower Speed - Variable Speed ECM

Variable speed ECM blower motors have 12 selectable speeds and are factory set for optimum performance. When applicable, the speed settings may also be adjusted through the Building Automation System (BAS).



CAUTION: Disconnect all power before performing this operation.

Blower Performance Data cont.

Setting Blower Speed - Variable Speed ECM

The ABC board's Yellow Config LED will flash the current variable speed ECM blower speed selections for low, med, and high continuously with a short pause in between. The speeds can also be confirmed with the AID Tool under the Setup/ECM Setup screen. The variable speed ECM blower motor speeds can be field adjusted with or without using an AID Tool.

Variable Speed ECM Setup without an AID Tool

The blower speeds for Low (G only), Med (Y1), and High (Y2/Aux) can be adjusted directly at the Aurora ABC board which utilizes the push button (SW1) on the ABC board. This procedure is outlined in the Variable Speed ECM Configuration Mode portion of the Aurora 'Base' Control System section.

Variable Speed ECM Setup with an AID Tool

A much easier method utilizes the AID Tool to change the airflow using the procedure below. First navigate to the Setup screen and then select ECM Setup. This screen displays the current variable speed ECM settings. It allows the technician to enter the setup screens to change the variable speed ECM settings. Change the highlighted item using the ◀ and ▶ buttons and then press the ◻ button to select the item.

Variable Speed ECM Setup with an AID Tool cont.

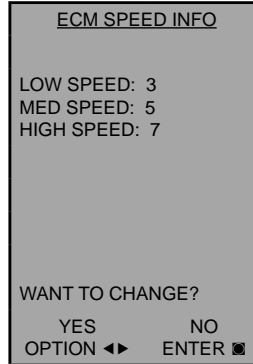

Selecting YES will enter variable speed ECM speed setup, while selecting NO will return to the previous screen.

Variable Speed ECM Speed Setup - These screens allow the technician to select the low, medium, and high blower speed for the variable speed ECM blower motor. Change the highlighted item using the ▲ and ▼ buttons. Press the ◻ button to select the speed.

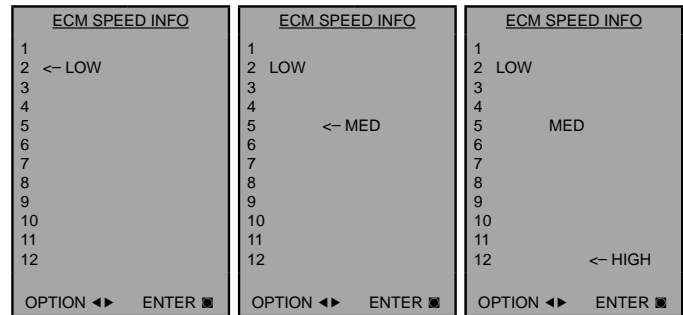

After the high speed setting is selected the AID Tool will automatically transfer back to the ECM Setup screen.

Wiring Schematics

Aurora Base Control 208-230/60/1 PSC

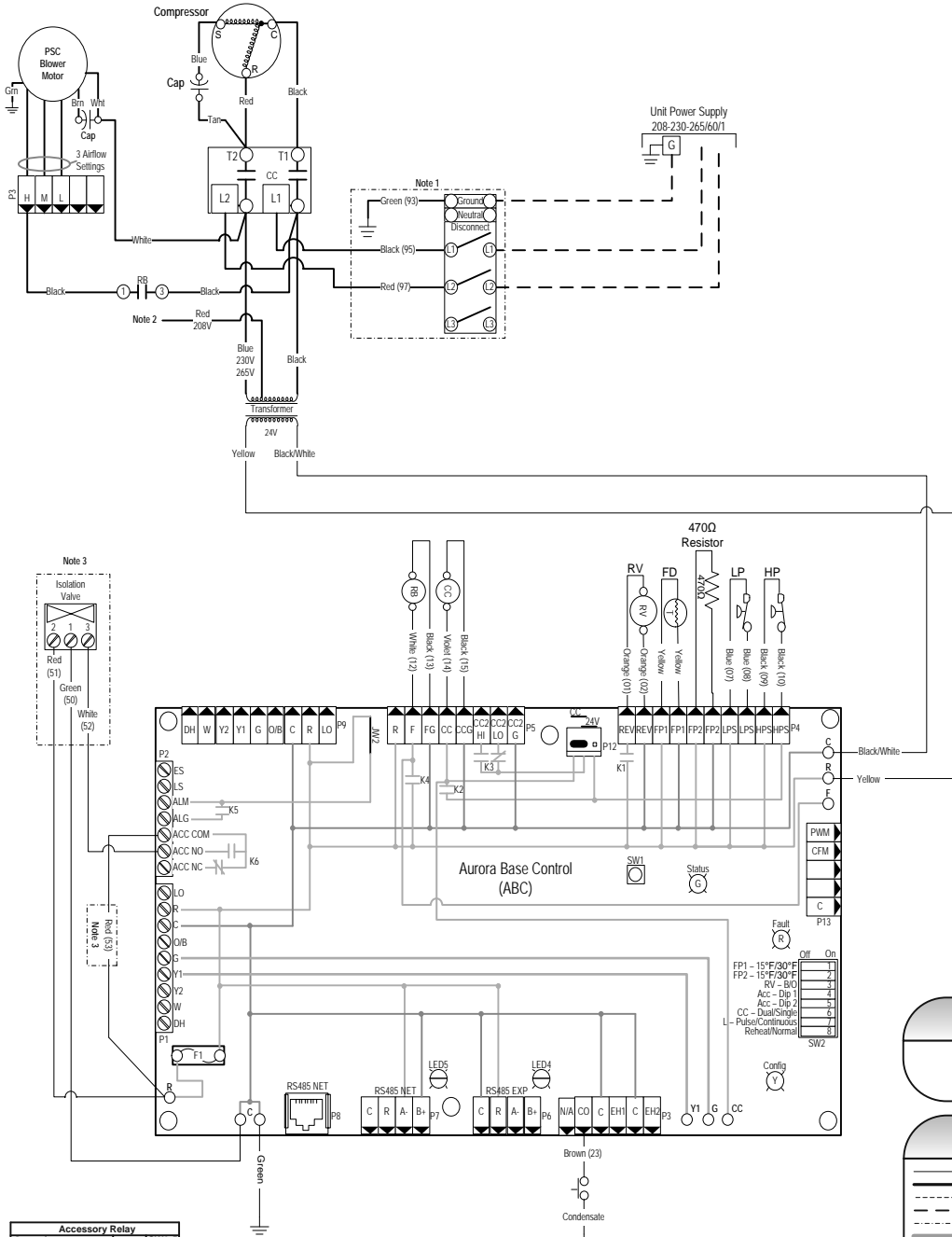

Accessory Relay		
Operation	SW2-4	SW2-5
Cycle with Blower	On	On
Cycle with Compressor	Off	Off
Water Valve Slow Open	On	Off
Outdoor Air Dampers	Off	On

Aurora Timing Events		
Event	Normal Mode	Test Mode
Random Start Delay	5 to 30 seconds	1 second
Compressor On Delay	5 seconds	< 1 second
Compressor Minimum On Time	2 minutes	5 seconds
Compressor Short Cycle Delay	4 minutes	15 seconds
Blower Off Delay	30 seconds	2 seconds
Fault Recognition Delay - High Pressure	Less than 1 second	Less than 1 second
Start-Up Bypass - Low Pressure	2 minutes	30 seconds
Fault Recognition Delay - Low Pressure	30 seconds	30 seconds
Start-Up Bypass - Low Water/Air Coil Limit	2 minutes	30 seconds
Fault Recognition Delay - Low Water/Air Coil Limit	30 seconds	30 seconds
Fault Recognition Delay - Condensate Overflow	2 seconds	30 seconds
Thermostat Call Recognition Time	2 seconds	2 seconds
Auxiliary Heat Staging Delay	5 minutes	20 seconds
Emergency Heat Staging Delay	2 minutes	7.5 seconds
Water Valve Slow Open Delay	30 seconds	30 seconds
Reheat Delay	30 seconds	30 seconds

Aurora LED Flash Codes			
Slow Flash	1 second on and 1 second off		
Fast Flash	100 milliseconds on and 100 milliseconds off		
Flash Code	100 milliseconds on and 400 milliseconds off with a 2 second pause before repeating		
Test Mode	Random Start Delay	Fast Flash	Fast Flash
Configuration LED (LED2, Yellow)	Fast Flash	Fast Flash	Fast Flash
Fault LED (LED3, Red)	Fast Flash	Fast Flash	Fast Flash
Status LED (LED1, Green)	Configuration LED (LED2, Yellow)	Fault LED (LED3, Red)	
Normal Mode	ON	No Software Override	Flash ECM Setting
Control is Non-Functional	OFF	DIP Switch Override	Slow Flash
Test Mode	Slow Flash	ECM Configure Mode	Fast Flash
Lockout Active	Fast Flash	Reset Configure Mode	Off
Dehumidification Mode	Flash Code 3		Low Air Coil Limit Lockout - FP2
Reserved	Flash Code 4		Low Water Coil Limit Lockout - FP1
Reserved	Flash Code 5		Reserved
Load Shed	Flash Code 6		Condensate Overflow Lockout
ESD	Flash Code 7		Over/Under Voltage Shutdown
Reserved	Flash Code 8		Reserved
	Flash Code 9		Reserved
	Flash Code 10		Reserved
	Flash Code 11		Air/Water Coil Limit Sensor Error

- Notes:**
- 1 - Optional, factory installed unit mounted disconnect.
 - 2 - Swap blue and red leads for 208V operation.
 - 3 - Optional, factory installed internal isolation valve.

Legend

- Factory Low Voltage Wiring
- Factory Line Voltage Wiring
- Field Low Voltage Wiring
- Field Line Voltage Wiring
- Optional Block
- DC Voltage PCB Traces
- Field Zone Sensor Wiring
- Internal Junction
- Quick Connect Terminal
- Field Wiring Lug
- Ground
- Relay Contacts - N.O., N.C.
- Capacitor
- Fuse
- Thermistor
- Relay Coil
- Switch - Condensate Overflow
- Switch - High pressure
- Switch - Low pressure
- Polarized connector
- Light Emitting Diode - Green
- Light Emitting Diode - Yellow
- Light Emitting Diode - Red

CC - Compressor Contactor
 CO - Condensate Overflow Sensor
 ES - Emergency Shutdown
 HP - High Pressure Switch
 LP - Low Pressure Switch
 FD - Freeze Detection Sensor
 F1 - Fuse

SW1 - Push button
 SW2 - DIP package 8 position
 RB - Blower Relay
 RV - Reversing Valve Coil

Wiring Schematics cont.

Aurora Base Control 460/60/3 Variable Speed ECM

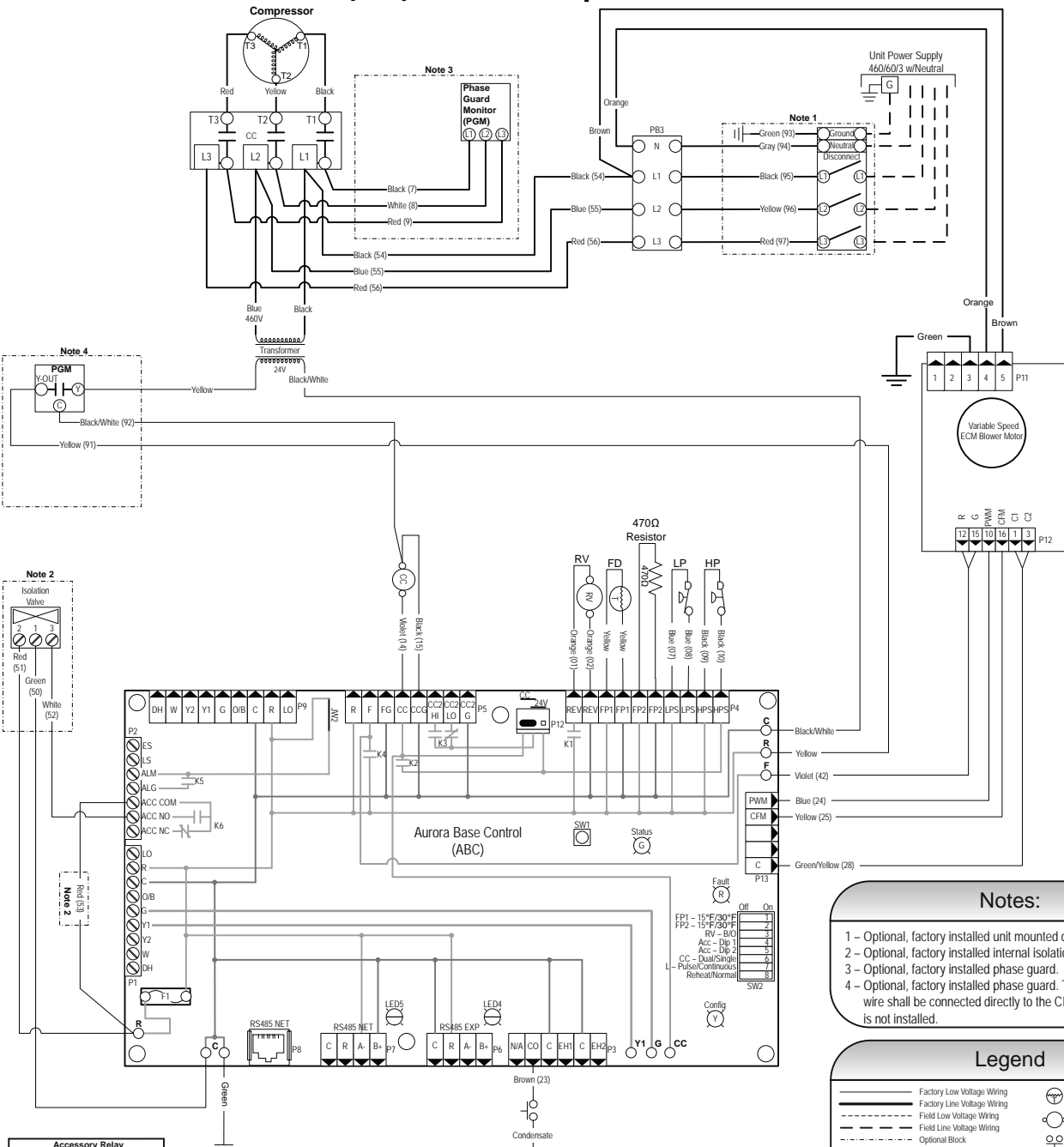

Accessory Relay		
Operation	SW2-4	SW2-5
Cycle with Blower	On	On
Cycle with Compressor	Off	Off
Water Valve Slow Open	On	Off
Outdoor Air Damper	Off	On

Aurora Timing Events		
Event	Normal Mode	Test Mode
Random Start Delay	5 to 80 seconds	1 second
Compressor On Delay	5 seconds	< 1 second
Compressor Minimum On Time	2 minutes	5 seconds
Compressor Start Cycle Delay	4 minutes	15 seconds
Blower Off Delay	30 seconds	2 seconds
Fault Recognition Delay - High Pressure	Less than 1 second	Less than 1 second
Start-Up Bypass - Low Pressure	2 minutes	30 seconds
Fault Recognition Delay - Low Pressure	30 seconds	30 seconds
Start-Up Bypass - Low Water/Air Coil Limit	2 minutes	30 seconds
Fault Recognition Delay - Low Water/Air Coil Limit	30 seconds	30 seconds
Fault Recognition Delay - Condensate Overflow	30 seconds	30 seconds
Thermostat Call Recognition Time	2 seconds	2 seconds
Auxiliary Heat Staging Delay	5 minutes	20 seconds
Emergency Heat Staging Delay	2 minutes	7.5 seconds
Water Valve Slow Open Delay	90 seconds	90 seconds
Reheat Delay	30 seconds	30 seconds

Aurora LED Flash Codes					
Slow Flash	1 second on and 1 second off				
Fast Flash	100 milliseconds on and 100 milliseconds off				
Flash Code	100 milliseconds on and 400 milliseconds off with a 2 second pause before repeating				
Random Start Delay					
Status LED (LED1, Green)	Fast Flash				
Configuration LED (LED2, Yellow)	Fast Flash				
Fault LED (LED3, Red)	Fast Flash				
Status LED (LED1, Green)					
Normal Mode	ON	No Software Override	Flash ECM Setting	Normal Mode	OFF
Control is Non-Functional	OFF	DIP Switch Override	Slow Flash	Input Fault Lockout	Flash Code 1
Reserved	Slow Flash	ECM Configure Mode	Fast Flash	High Pressure Lockout	Flash Code 2
Lockout Active	Fast Flash	Reset Configure Mode	Off	Low Pressure Lockout	Flash Code 3
Diagnostics/Configuration Mode					
Flash Code 2	Low Air Coil Limit Lockout - FP2				
Flash Code 3	Low Water Coil Limit Lockout - FP1				
Flash Code 4	Reserved				
Flash Code 5	Reserved				
Flash Code 6	Condensate Overflow Lockout				
Flash Code 7	Over/Under Voltage Shutdown				
Flash Code 8	Reserved				
Flash Code 9	Reserved				
Flash Code 10	Reserved				
Flash Code 11	Air/Water Coil Limit Sensor Error				

- Notes:**
- Optional, factory installed unit mounted disconnect.
 - Optional, factory installed internal isolation valve.
 - Optional, factory installed phase guard.
 - Optional, factory installed phase guard. The yellow transformer wire shall be connected directly to the CPU board, if this option is not installed.

Legend

	Factory Low Voltage Wiring		Thermistor
	Factory Line Voltage Wiring		Relay Coil
	Field Low Voltage Wiring		Switch - Condensate Overflow
	Field Line Voltage Wiring		Switch - High pressure
	Optional Block		Switch - Low pressure
	DC Voltage PCB Traces		Polarized connector
	Field Zone Sensor Wiring		Light Emitting Diode - Green
	Internal Junction		Light Emitting Diode - Yellow
	Quick Connect Terminal		Light Emitting Diode - Red
	Field Wiring Lug		SW1 - Push button
	Ground		SW2 - DIP package 8 position
	Relay		RV - High pressure Switch
	Relay Contacts - N.O., N.C.		LP - Low Pressure Switch
	Capacitor		FD - Freeze Detection Sensor
	Fuse		PGM - Phase Guard Monitor
			RH - Reheat Valve Coil

CC - Compressor Contactor
 CO - Condensate Overflow Sensor
 ES - Emergency Shutdown
 FP2 - Dip package 8 position
 HP - High Pressure Switch
 LP - Low Pressure Switch
 FD - Freeze Detection Sensor
 PGM - Phase Guard Monitor
 RH - Reheat Valve Coil

Wiring Schematics cont.

Aurora Base Control 460/60/3 5-Speed ECM

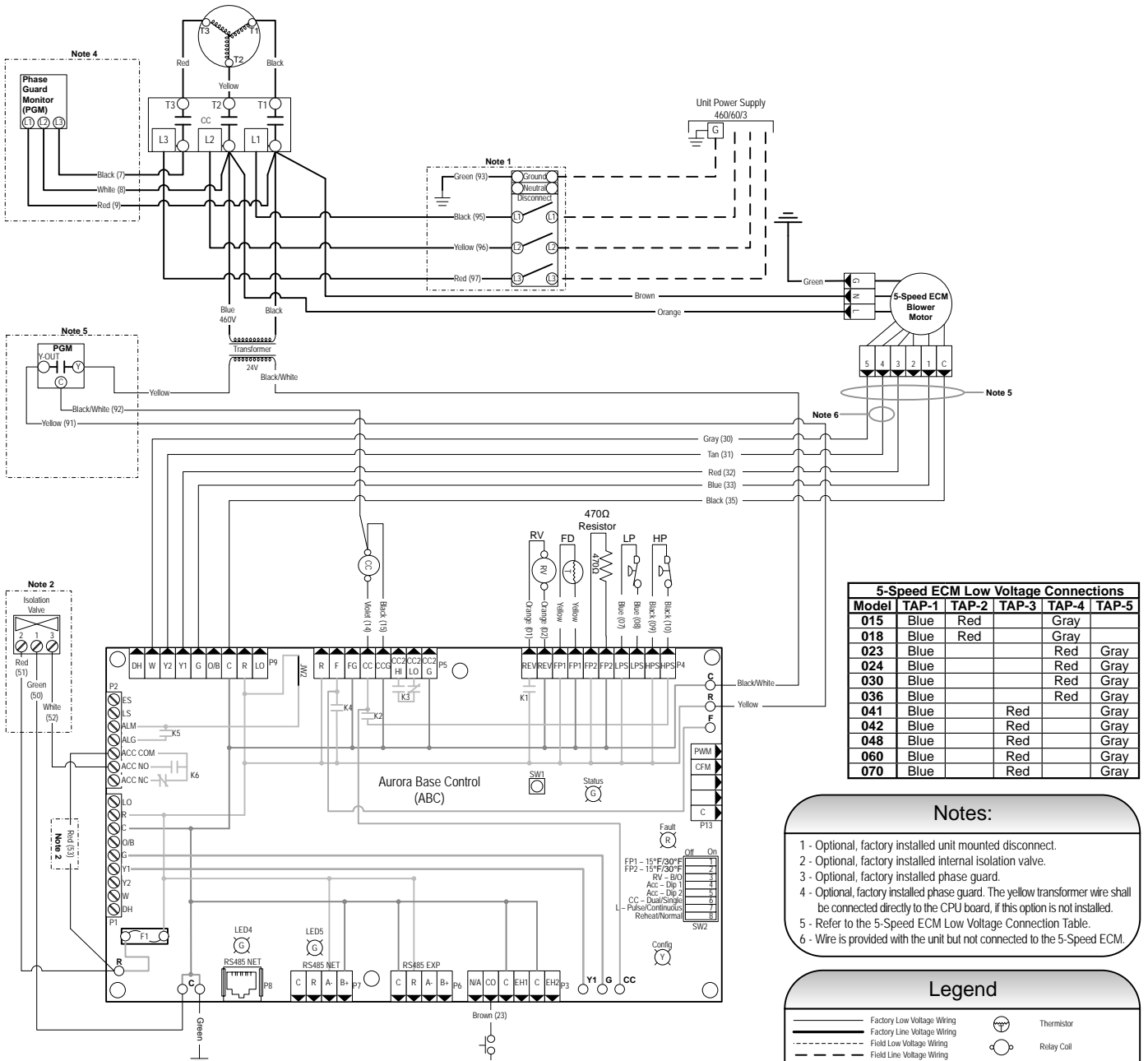

Model	TAP-1	TAP-2	TAP-3	TAP-4	TAP-5
015	Blue	Red		Gray	
023	Blue	Red		Gray	
024	Blue			Red	Gray
030	Blue			Red	Gray
036	Blue			Red	Gray
041	Blue		Red		Gray
042	Blue		Red		Gray
048	Blue		Red		Gray
060	Blue		Red		Gray
070	Blue		Red		Gray

- Notes:**
- 1 - Optional, factory installed unit mounted disconnect.
 - 2 - Optional, factory installed internal isolation valve.
 - 3 - Optional, factory installed phase guard.
 - 4 - Optional, factory installed phase guard. The yellow transformer wire shall be connected directly to the CPU board, if this option is not installed.
 - 5 - Refer to the 5-Speed ECM Low Voltage Connection Table.
 - 6 - Wire is provided with the unit but not connected to the 5-Speed ECM.

Legend

- Factory Low Voltage Wiring
- Factory Line Voltage Wiring
- Field Low Voltage Wiring
- Field Line Voltage Wiring
- Optional Block
- DC Voltage PCB Traces
- Field Zone Sensor Wiring
- Internal Junction
- Quick Connect Terminal
- Thermistor
- Relay Coil
- Switch - Condensate Overflow
- Switch - High pressure
- Switch - Low pressure
- Polarized connector
- Ground
- Relay Contacts - N.O., N.C.
- Capacitor
- Fuse
- Light Emitting Diode - Green
- Light Emitting Diode - Yellow
- Light Emitting Diode - Red

CC - Compressor Contactor
 CO - Condensate Overflow Sensor
 ES - Emergency Shutdown
 HP - High Pressure Switch
 LP - Low Pressure Switch
 FD - Freeze Detection Sensor
 F1 - Fuse
 SW1 - Push button
 SW2 - DIP package 8 position
 RB - Blower Relay
 RV - Reversing Valve Coil
 PGM - Phase Guard Monitor
 RH - Reheat Valve Coil

Operation	SW2-4	SW2-5
Cycle with Blower	On	On
Cycle with Compressor	Off	Off
Water Valve Slow Open	On	Off
Outdoor Air Bumper	Off	On

Event	Normal Mode	Test Mode
Random Start Delay	3 to 80 seconds	1 second
Compressor On Delay	5 seconds	< 1 second
Compressor Minimum On Time	2 minutes	5 seconds
Compressor Short Cycle Delay	4 minutes	15 seconds
Blower Off Delay	30 seconds	2 seconds
Fault Recognition Delay - High Pressure	Less than 1 second	Less than 1 second
Start-Up Bypass - Low Pressure	2 minutes	30 seconds
Fault Recognition Delay - Low Pressure	30 seconds	30 seconds
Start-Up Bypass - Low Water/Air Coil Limit	2 minutes	30 seconds
Fault Recognition Delay - Low Water/Air Coil Limit	30 seconds	30 seconds
Fault Recognition Delay - Condensate Overflow	30 seconds	30 seconds
Thermostat Call Recognition Time	2 seconds	2 seconds
Auxiliary Heat Staging Delay	5 minutes	20 seconds
Emergency Heat Staging Delay	2 minutes	7.5 seconds
Water Valve Slow Open Delay	90 seconds	90 seconds
Reheat Delay	30 seconds	30 seconds

Flash Code	Meaning
Slow Flash	1 second on and 1 second off
Fast Flash	100 milliseconds on and 100 milliseconds off
Flash Code	100 milliseconds on and 400 milliseconds off with a 2 second pause before repeating
Random Start Delay	<ul style="list-style-type: none"> Status LED (LED1, Green): Fast Flash Configuration LED (LED2, Yellow): Fast Flash Fault LED (LED3, Red): Fast Flash
Status LED (LED1, Green)	<ul style="list-style-type: none"> Normal Mode: ON Control is Non-Functional: OFF Test Mode: Slow Flash Lockout Active: Fast Flash Dehumidification Mode: Flash Code 2 Reserved: Flash Code 3 Reserved: Flash Code 4 Load Shed: Flash Code 5 ESD: Flash Code 6 Reserved: Flash Code 7
Configuration LED (LED2, Yellow)	<ul style="list-style-type: none"> No Software Overrides: OFF DIP Switch Overrides: Slow Flash ECM Configure Mode: Fast Flash Reset Configure Mode: OFF Flash Code 2: Low Air Coil Limit Lockout - FP2 Flash Code 3: Reserved Flash Code 4: Reserved Flash Code 5: Low Water Coil Limit Lockout - FP1 Flash Code 6: Reserved Flash Code 7: Condensate Overflow Lockout Flash Code 8: Over/Under Voltage Shutdown Flash Code 9: Reserved Flash Code 10: Reserved Flash Code 11: Air/Water Coil Limit Sensor Error
Fault LED (LED3, Red)	<ul style="list-style-type: none"> Normal Mode: OFF Input Fault Lockout: Flash Code 1 High Pressure Lockout: Flash Code 2 Low Pressure Lockout: Flash Code 3 Low Air Coil Limit Lockout - FP2: Flash Code 4 Low Water Coil Limit Lockout - FP1: Flash Code 5 Flash Code 6: Reserved Flash Code 7: Condensate Overflow Lockout Flash Code 8: Over/Under Voltage Shutdown Flash Code 9: Reserved Flash Code 10: Reserved Flash Code 11: Air/Water Coil Limit Sensor Error

Wiring Schematics cont.

Aurora Control with UPC

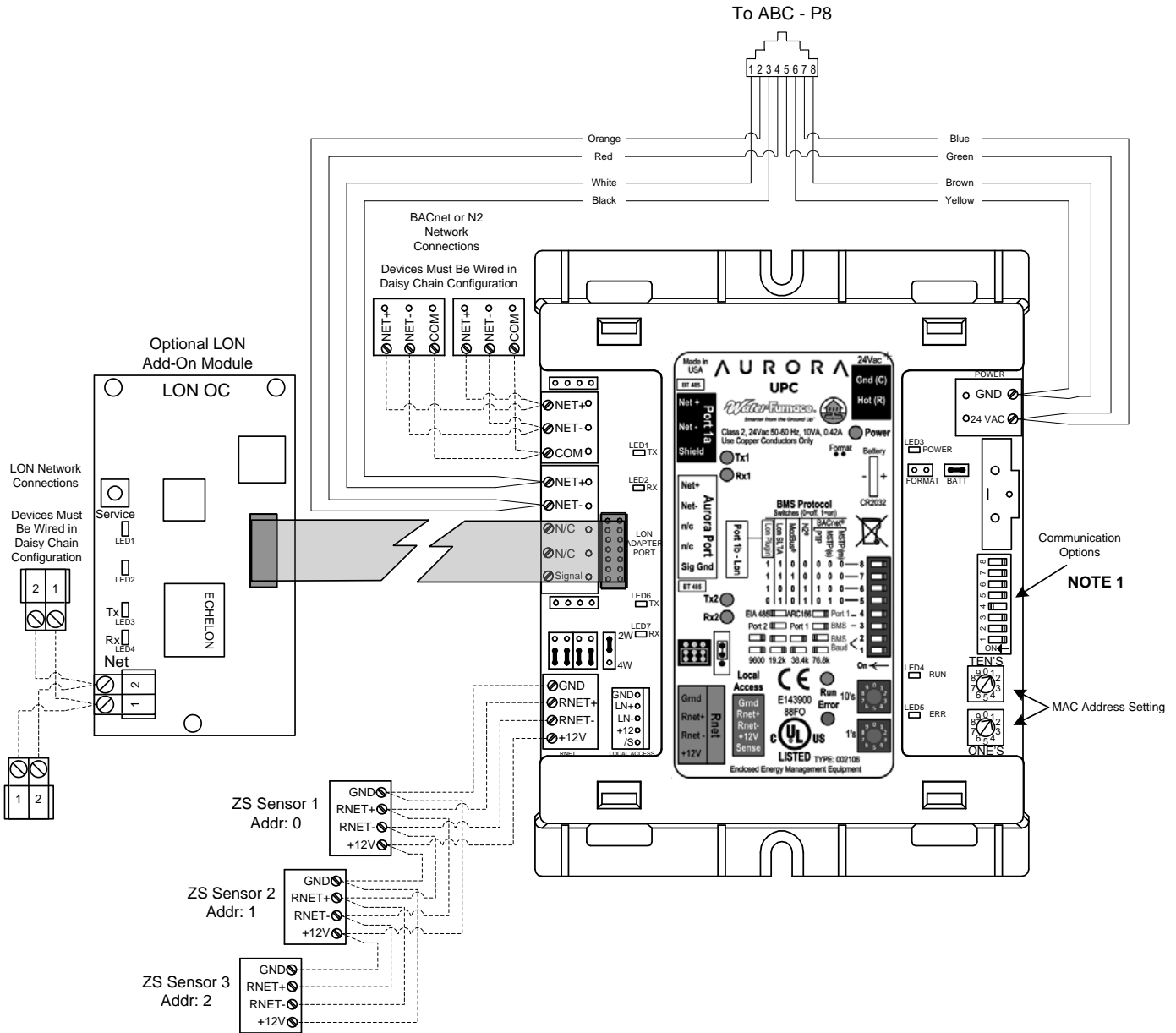

ZS Sensor Information

Zone Sensors can be wired in daisy chain as show or in a star or hybrid configuration. Maximum of 5 sensors per UPC. Maximum allowable load 210mA. See the UPC install manual for possible sensor combinations.

DIP Switch Value



Each ZS sensor must have a unique address, but the addresses do not need to be sequential. Use the DIP switches on the back of the ZS sensor to set an address from 0 to 4. (0 is the factory default.) Each DIP switch has the value shown in the figure to the left. Turn on as many DIP switches as you need so that their total value equals the address.

Notes

1. Use DIP Switches 5 – 8 to change communication protocol and DIP switches 1 – 2 to change BACnet baud rate

Legend

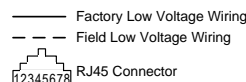

Controls - Aurora Base Control

Aurora 'Base' Control



NOTE: Refer to the Aurora Base Control Application and Troubleshooting Guide and the Instruction Guide: Aurora Interface and Diagnostics (AID) Tool for additional information.

Control Features

Software ABC Standard Version 2.0

Single or Dual Capacity Compressors

Either single or dual capacity compressors can be operated.

Variable Speed ECM Blower Motor Option

A Variable Speed ECM blower motor can be driven directly using the onboard PWM output. Four blower speeds are available based upon the G, Y1, Y2, and W input signals to the board. The blower speeds can be changed either by the ECM manual configurations mode method or by using the Aurora AID Tool directly. All four blower speeds can be set to the same speed if desired.

5-Speed ECM Blower Motor Option

A 5-Speed ECM blower motor will be driven directly using the thermostat connections. Any of the G, Y1, or Y2/W signals can drive any of the 5 available pre-programmed blower speeds on the motor. All 5 Series "G" vintage units will be wired this way at the factory.

Other Control Features

- Random start at power up
- Anti-short cycle protection
- High and low pressure cutouts
- Loss of charge
- Water coil freeze detection
- Air coil freeze detection
- Over/under voltage protection
- Condensate overflow sensor
- Load shed
- Dehumidification (where applicable)
- Emergency shutdown
- Hot gas reheat operation (where applicable)
- Diagnostic LED
- Test mode push button switch
- Two auxiliary electric heat outputs
- Alarm output
- Accessory output with N.O. and N.C.
- Modbus communication (master)
- Modbus communication (slave)

Field Selectable Options via Hardware

DIP Switch (SW1) – Test/Configuration Button (See SW1 Operation Table)

Test Mode

The control is placed in the test mode by holding the push button switch SW1 for 2 - 5 seconds. In test mode most of the control timings will be shortened by a factor of sixteen (16). LED3 (green) will flash at 1 second on and 1 second off. Additionally, when entering test mode LED1 (red) will flash the last lockout one time. Test mode will automatically time out after 30 minutes. Test mode can be exited by pressing and holding the SW1 button for 2 to 5 seconds or by cycling the power. **NOTE:** Test mode will automatically be exited after 30 minutes.

ECM Configuration Mode

The control is placed in the ECM configuration mode by holding the pushbutton switch SW1 for 5 to 10 seconds, the high, low, and "G" ECM speeds can be selected by following the LED display lights. LED2 (yellow) will fast flash when entering the ECM configuration. When setting "G" speed LED3 (green) will be continuously lit, for low speed LED1 (red) will be continuously lit, and for high speed both LED3 (green) and LED1 (red) will be continuously lit. During the ECM configuration mode LED2 (yellow) will flash each of the 12 possible blower speeds 3 times. When the desired speed is flashed press SW1, LED2 will fast flash until SW1 is released. "G" speed has now been selected. Next select low speed, and high speed blower selections following the same process above. After third selection has been made, the control will exit the ECM configuration mode. Aux fan speed will remain at default or current setting and requires the AID Tool for adjustment.

Reset Configuration Mode

The control is placed in reset configuration mode by holding the push button switch SW1 for 50 to 60 seconds. This will reset all configuration settings and the EEPROM back to the factory default settings. LED3 (green) will turn off when entering reset configuration mode. Once LED3 (green) turns off, release SW1 and the control will reset.

DIP Switch (SW2)

- SW2-1** FP1 Selection – Low water coil temperature limit setting for freeze detection. On = 30°F; Off = 15°F.
- SW2-2** FP2 Selection – On = 30°F; Off = N/A
- SW2-3** RV – O/B - thermostat type. Heat pump thermostats with "O" output in cooling or "B" output in Heating can be selected. On = O; Off = B.
- SW2-4 and 2-5** Access Relay Operation (P2)

Access Relay Operation	SW2-4	SW2-5
Cycle with Blower	ON	ON
Cycle with Compressor	OFF	OFF
Water Valve Slow Opening	ON	OFF
Cycle with Comm. T-stat Hum Cmd	OFF	ON

Controls - Aurora Base Control cont.

Cycle with Blower - The accessory relay will cycle with the blower output.

Cycle with Compressor - The accessory relay will cycle with the compressor output.

Water Valve Slow Opening - The accessory relay will cycle and delay both the blower and compressor output for 90 seconds.

SW2-6 CC Operation - selection of single or dual capacity compressor. On = Single Stage; Off = Dual Capacity

SW2-7 Lockout and Alarm Outputs (P2) - selection of a continuous or pulsed output for both the LO and ALM Outputs. On = Continuous; Off = Pulsed

SW2-8 Future Use

Alarm Jumper Clip Selection

From the factory, ALM is connected to 24 VAC via JW2. By cutting JW2, ALM becomes a dry contact connected to ALG.

ECM Blower Speeds

The blower speeds can be changed either by using the ECM manual configurations mode method or by using the Aurora AID Tool directly (see Instruction Guide: Aurora Interface and Diagnostics (AID) Tool topic).

Field Selectable Options via Software

(Selectable via the Aurora AID Tool)

ECM Blower Speeds

An ECM blower motor can be driven directly using the onboard PWM output. Four blower speeds are available, based upon the "G", Y1 (low), Y2 (high), and Aux input signals to the board. The blower speeds can be changed either by the ECM manual configurations mode method (see ECM Configuration Mode topic) or by using the Aurora AID Tool directly. All four blower speeds can be set to the same speed if desired. Aux blower speed will remain at default or current setting and requires the AID Tool for adjustment.

Safety Features

The following safety features are provided to protect the compressor, heat exchangers, wiring and other components from damage caused by operation outside of design conditions.

Fuse - a 3 amp automotive type plug-in fuse provides protection against short circuit or overload conditions.

Anti-Short Cycle Protection - 4 minute anti-short cycle protection for the compressor.

Random Start - 5 to 80 second random start upon power up.

Fault Retry - in the fault condition, the control will stage off the outputs and then "try again" to satisfy the thermostat Y input call. Once the thermostat input calls are satisfied, the control will continue on as if no fault occurred. If 3 consecutive faults occur without satisfying the thermostat Y input call, then the control will go to Lockout mode.

Lockout - when locked out, the blower will operate continuously in "G" speed, and PSC blower motor output will remain on. The Alarm output (ALM) and Lockout output (L) will be turned on. The fault type identification display LED1 (Red) shall flash the fault code. To reset lockout conditions with SW2-8 On, thermostat inputs "Y1", "Y2", and "W" must be removed for at least 3 seconds. To reset lockout conditions with SW2-8 Off, thermostat inputs "Y1", "Y2", "W", and "DH" must be removed for at least 3 seconds. Lockout may also be reset by turning power off for at least 30 seconds or by enabling the emergency shutdown input for at least 3 seconds.

Lockout With Emergency Heat - if the control is locked out in the heating mode, and a Y2 or W input is received, the control will operate in the emergency heat mode while the compressor is locked out. The first emergency heat output will be energized 10 seconds after the W input is received, and the blower will shift to high speed. If the control remains locked out, and the W input is present, additional stage of emergency heat will stage on after 2 minutes. When the W input is removed, all of the emergency heat outputs will turn off, and the ECM blower will shift to "G" speed and PSC blower motor output will remain on.

High Pressure - fault is recognized when the Normally Closed High Pressure Switch, P4-9/10 opens, no matter how momentarily. The High Pressure Switch is electrically in series with the Compressor Contactor and serves as a hard-wired limit switch if an overpressure condition should occur.

Low Pressure - fault is recognized when the Normally Closed Low Pressure Switch, P4-7/8 is continuously open for 30 seconds. Closure of the LPS any time during the 30 second recognition time restarts the 30 second continuous open requirement. A continuously open LPS shall not be recognized during the 2 minute startup bypass time.

Loss of Charge - fault is recognized when the Normally Closed Low Pressure Switch, P4-7/8 is open prior to the compressor starting.

Condensate Overflow - fault is recognized when the impedance between this line and 24 VAC common or chassis ground drops below 100K ohms for 30 seconds continuously.

Freeze Detection (Coax) - set points shall be either 30°F or 15°F. When the thermistor temperature drops below the selected set point, the control shall begin counting down the 30 seconds delay. If the thermistor value rises above the selected set point, then the count should reset. The resistance value must remain below the selected set point for the entire length of the appropriate delay to be recognized as a fault. This fault will be ignored for the initial 2 minutes of the compressor run time.

Freeze Detection (Air Coil) - uses the FP2 input to protect against ice formation on the air coil. The FP2 input will operate exactly like FP1 except that the set point is 30 degrees and is not field adjustable.

Controls - Aurora Base Control cont.

Over/Under Voltage Shutdown - An over/under voltage condition exists when the control voltage is outside the range of 18 VAC to 30 VAC. If the over/under voltage shutdown lasts for 15 minutes, the lockout and alarm relay will be energized. Over/under voltage shutdown is self-resetting in that if the voltage comes back within range of 18 VAC to 30 VAC for at least 0.5 seconds, then normal operation is restored.

Operation Description

Power Up - The unit will not operate until all the inputs and safety controls are checked for normal conditions. The unit has a 5 to 80 second random start delay at power up. Then the compressor has a 4 minute anti-short cycle delay after the random start delay.

Standby In standby mode, Y1, Y2, W, DH, and G are not active. Input O may be active. The blower and compressor will be off.

Heating Operation

Heating, 1st Stage (Y1) - The blower is started on "G" speed immediately and the compressor is energized 10 seconds after the Y1 input is received. The ECM blower motor is switched to low speed 15 seconds after the Y1 input.

Heating, 2nd Stage (Y1, Y2) - The compressor will be staged to full capacity 20 seconds after Y2 input is received. The ECM blower will shift to high speed 15 seconds after the Y2 input is received.

Heating, 3rd Stage (Y1, Y2, W) - The hot water pump is de-energized and the first stage of electric heat is energized 10 seconds after the W command is received. If the demand continues the second stage of electric heat will be energized after 5 minutes.

Emergency Heat (W) - The blower will be started on "G" speed, 10 seconds later the first stage of electric heat will be turned on. 5 seconds after the first stage of electric heat is energized the blower will shift to Aux speed. If the emergency heat demand is not satisfied after 2 minutes the second electric heat stage will be energized.

Blower (G) - The blower will start immediately upon receiving a thermostat G command. If there are no other commands from the thermostat the ECM will run on "G" speed until the G command is removed. Regardless of blower input (G) from the thermostat, the blower will remain on for 30 seconds at the end of each heating cycle.

Cooling Operation

In all cooling operations, the reversing valve directly tracks the O input. Thus, anytime the O input is present, the reversing valve will be energized.

Cooling, 1st Stage (Y1, O) - The blower is started on "G" speed immediately and the compressor is energized 10 seconds after the Y1 input is received. The ECM blower motor is switched to low speed 15 seconds after the Y1 input.

Cooling, 2nd Stage (Y1, Y2, O) - The compressor will be staged to full capacity 20 seconds after Y2 input is received. The ECM blower will shift to high speed 15 seconds after the Y2 input is received.

Blower (G) - The blower will start immediately upon receiving a thermostat G command. If there are no other commands from the thermostat the ECM will run on "G" speed until the G command is removed. Regardless of blower input (G) from the thermostat, the blower will remain on for 30 seconds at the end of each heating, cooling, and emergency heat cycle.

Dehumidification (Y1, O, DH or Y1, Y2, O, DH) - When a DH command is received from the thermostat during a compressor call for cooling the ECM blower speed will be reduced by 15% to increase dehumidification.

Emergency Shutdown - Four (4) seconds after a valid ES input, P2-7 is present, all control outputs will be turned off and remain off until the emergency shutdown input is no longer present. The first time that the compressor is started after the control exits the emergency shutdown mode, there will be an anti-short cycle delay followed by a random start delay. Input must be tied to common to activate.

Continuous Blower Operation - The blower output will be energized any time the control has a G input present, unless the control has an emergency shutdown input present. The blower output will be turned off when G input is removed.

Load Shed - The LS input disables all outputs with the exception of the blower output. When the LS input has been cleared, the anti-short cycle timer and random start timer will be initiated. Input must be tied to common to activate.

Controls - Aurora Base Control cont.

Aurora 'Base' Control LED Displays

These three LEDs display the status, configuration, and fault codes for the control. These can also be read in plain English via the Aurora AID Tool.

Status LED (LED3, Green)

Description of Operation	Fault LED, Green
Normal Mode	ON
Control is Non-functional	OFF
Test Mode	Slow Flash
Lockout Active	Fast Flash
Dehumidification Mode	Flash Code 2
(Future Use)	Flash Code 3
(Future Use)	Flash Code 4
Load Shed	Flash Code 5
ESD	Flash Code 6
(Future Use)	Flash Code 7

Configuration LED (LED2, Yellow)

Description of Operation	Configuration LED, Yellow
No Software Overwritten	Flashing ECM Setting
DIP Switch was Overwritten	Slow Flash
ECM Configuration Mode	Fast Flash

Fault LED (LED1, Red)

Red Fault LED		LED Flash Code*	Lockout	Reset/Remove
ABC Basic Faults	Normal - No Faults	OFF	-	
	Fault - Input	1	No	Auto
	Fault - High Pressure	2	Yes	Hard or Soft
	Fault - Low Pressure	3	Yes	Hard or Soft
	Fault - Freeze Detection FP2	4	Yes	Hard or Soft
	Fault - Freeze Detection FP1	5	Yes	Hard or Soft
	Fault - Condensate Overflow	7	Yes	Hard or Soft
	Fault - Over/Under Voltage	8	No	Auto
	Fault - FP1 & FP2 Sensor Error	11	Yes	Hard or Soft

NOTE: All codes >11 use long flash for tens digit and short flash for the ones digit. 20, 30, 40, 50, etc. are skipped.

Aurora Interface and Diagnostics (AID) Tool

The Aurora Interface and Diagnostics (AID) Tool is a device that is a member of the Aurora network. The AID Tool is used to troubleshoot equipment which uses the Aurora control via Modbus RTU communication. The AID Tool provides diagnostics, fault management, ECM setup, and system configuration capabilities to the Aurora family of controls. An AID Tool is recommended, although not required, for ECM airflow settings. The AID Tool simply plugs into the exterior of the cabinet in the AID Tool port.



ABC Control Board Layout

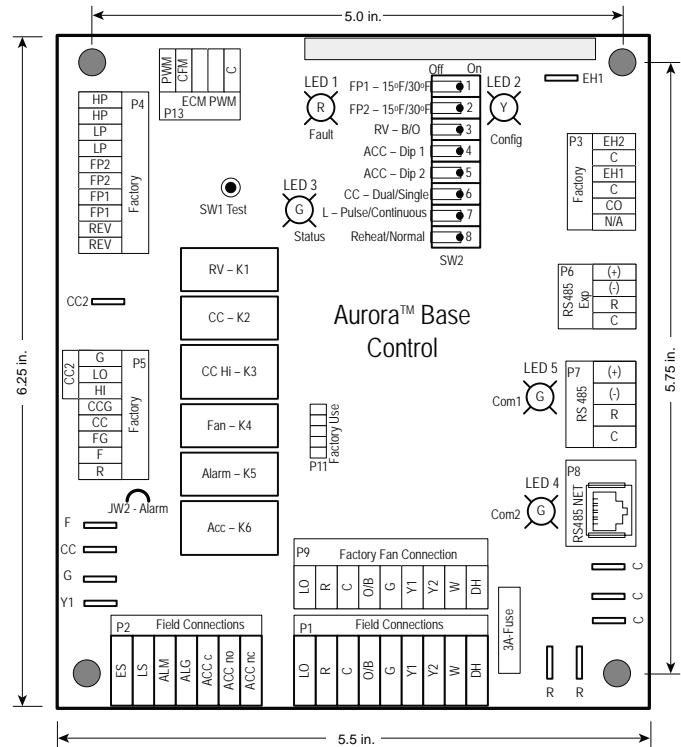

Controls - UPC DDC Control (optional)



Aurora UPC Controller

The Aurora Unitary Protocol Converter (UPC) is designed to add-on to any Aurora based heat pump control. The Aurora Unitary Protocol Converter (UPC) is designed to allow water source heat pumps to be integrated into Building Automation Systems (BAS) with ease. The Aurora UPC is an integrated solution and communicates directly with the Aurora Heat Pump Controls and allows access/control of a variety of internal Aurora heat pump operations such as sensors, relay operation, faults and other information. In turn, the UPC then converts internal Aurora Modbus protocol to BACnet MS/TP, LON, or N2 protocols and communicates to the BAS system. This provides the great benefit of complete control integration and a myriad of information available to the BAS from the heat pump control. Plus it also allows individual unit configuration such as ECM fan speeds or freeze protection setting directly over the BAS without the need for access to the actual heat pump. The Aurora UPC is programmed using the powerful Eikon object oriented.

The Aurora UPC is implemented with the Aurora Base Controller (ABC) heat pump control into our latest water source heat pumps. This will allow for a BAS to integrate



ZS Series Sensors

and communicate to the heat pump thru a choice of 3 different communication protocols. The Aurora UPC has the ability to communicate BACnet MS/TP, N2 open, or LonWorks (requires LON Plugin card). This flexibility is possible due to the onboard dipswitches which allow for the desired protocol and baud rate to be selected in the field. All zone temperatures and zone sensors are connected to the UPC on an RNet bus, simplifying hook up at the unit. RNet sensors can include a combination of zone temperature and humidity, CO₂, and VOC sensors. The UPC includes built-in support for a custom configurable keypad/display unit - BACview6 (4-line by 40 character per line display) or BACview5 (2-line by 16 character per line display). Up to 2 Keypad/display units can be mounted remotely for configuration and troubleshooting.

There are an extensive number of points that the UPC has available over the network for integration into the BAS. Control programmers need to carefully determine which points they want to add into the BAS database. A list of the BACnet points, N2 points, and LON SNVTs are available along with their individual point descriptions by contacting the Commercial Solutions Group at 1-877-677-4420.

Controls - UPC DDC Control (optional) cont.

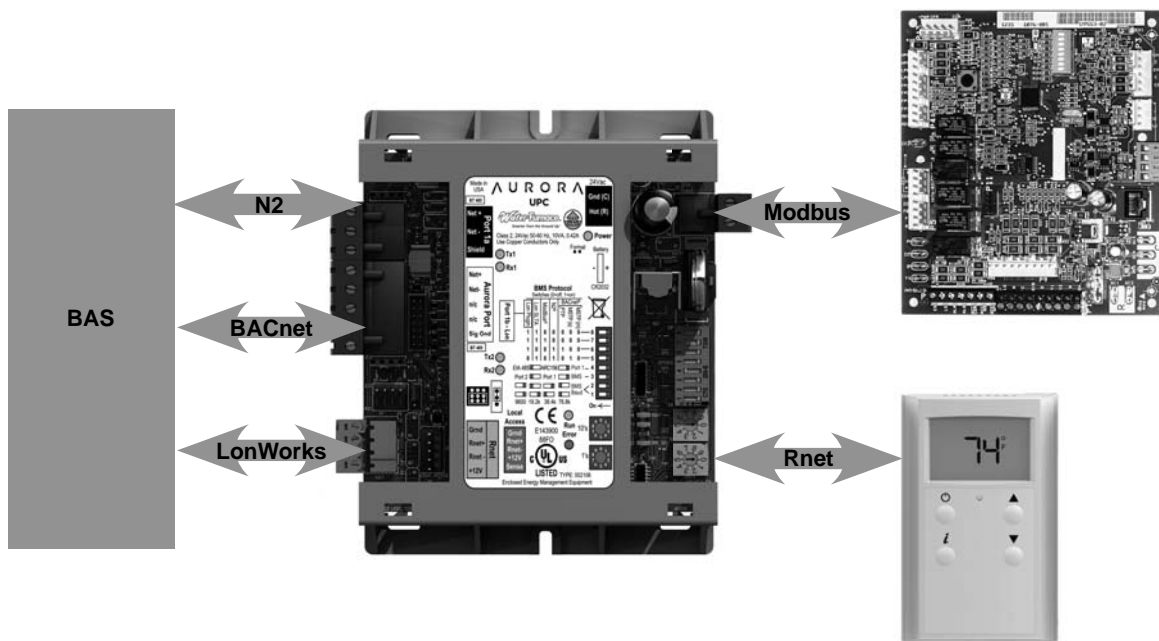

Aurora UPC Features

- Rugged enclosure made of GE C2950 Cycloy plastic
- Built-in surge transient protection circuitry
- Operating range of -20° to 140°F; 10 to 95% relative humidity, non-condensing
- Onboard CR123A battery has a life of 10 years with 720 hours of cumulative power outage
- Multi-Protocol field selectable communication port that supports:
 - EIA-485 BACnet MS/TP @ 9600, 19.2k, 38.4k, 76.8k baud
 - Metasys N2 Open
 - LonWorks TP/FT-10 (Requires optional LON plug-in communication card)
- Status of all unit operating conditions and fault lockouts
- Visual LED's for status of power, network communication, processor operation, and errors
- Provides gateway into Aurora heat pump controls for unsurpassed control flexibility
 - Network point for commanding unit into load shed
 - Network point for commanding unit into emergency shutdown
 - Network points to assist in fan speed selection
 - Network points for freeze protection settings
- Heating and cooling control from a remotely located zone sensor
- Rnet communication port which allows for multiple Rnet zone sensors (5) to be connected for space temperature averaging if desired.
- Local laptop or BACview connection for field service
- FCC, UL and CE listed. BTL Certification is pending

Aurora UPC Optional Features

- BACview handheld display, needed for field configuration of fan speeds, set points, etc.
- AID Tool for Aurora ABC configuration and troubleshooting.
- Aurora Advanced Control adds the Aurora AXB expansion board and provides added I/O and standard features
- Optional Sensor Kits (requires Aurora Advanced Control with AXB - Future Availability on Select Models/Configurations)
 - **Refrigeration Monitoring** - provides Suction and discharge pressure, Suction, liquid line temps and superheat and subcooling.
 - **Performance Monitoring** - provides entering and leaving loop water temperatures, loop flow rate as well as heat of extraction or rejection rate into the loop.
 - **Energy Monitoring** - provides real-time power measurement (Watt) of compressor, fan, auxiliary heat and zone pump.
- Graphics packages available in the future

Controls - UPC DDC Control (optional) cont.

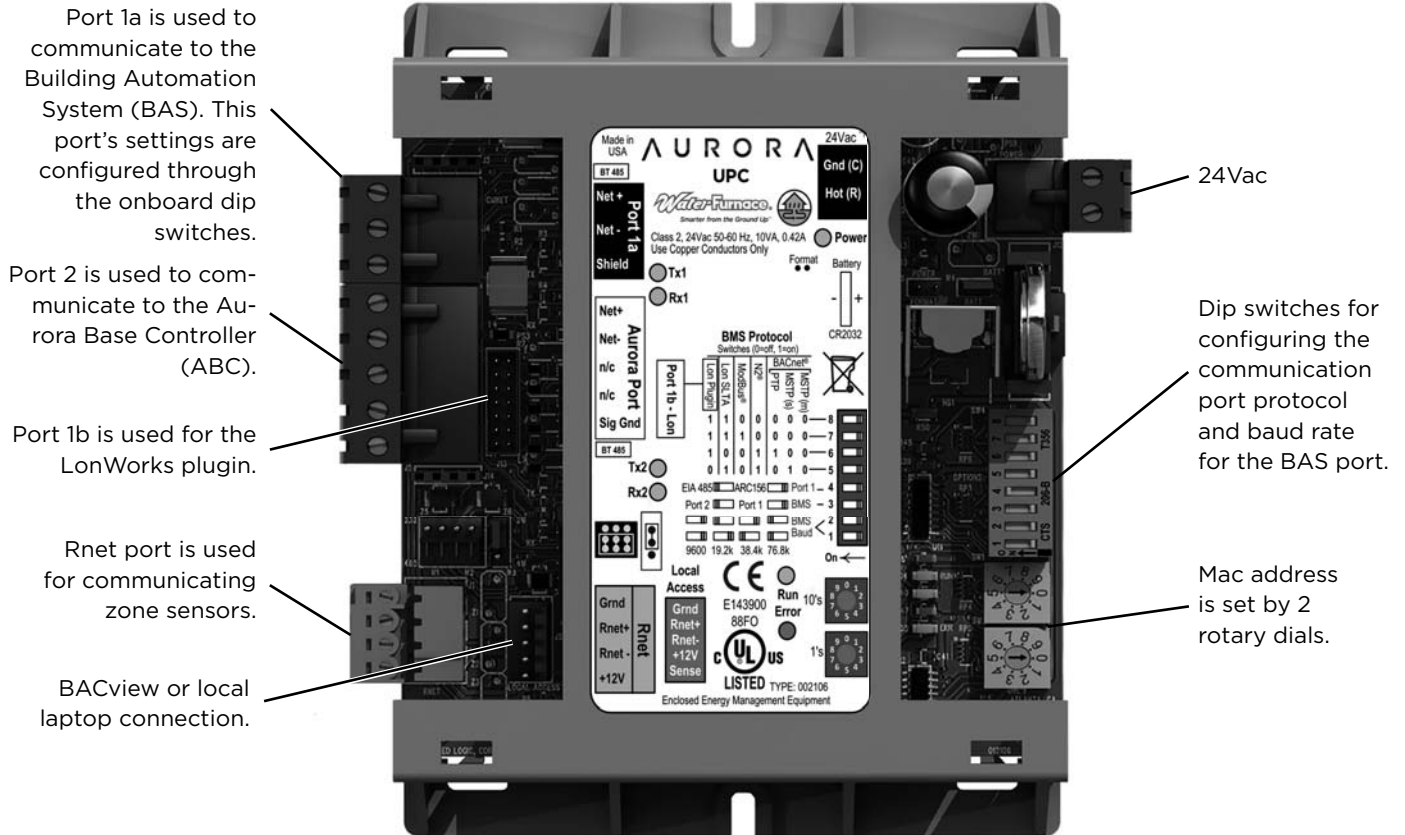

Aurora Touch Interface

Utilizing a touch-screen interface, the UPC provides a technician the ability to configure and diagnose equipment at the unit or from any room sensor for added accessibility and simpler troubleshooting. The technician will have full access to equipment status, parameter values, temperature, and humidity sensing as well as access to alarm and trend history. With website-like navigation, the Aurora Touch Interface is easy to use and provides important insight into the system so your building can operate as efficiently as possible.

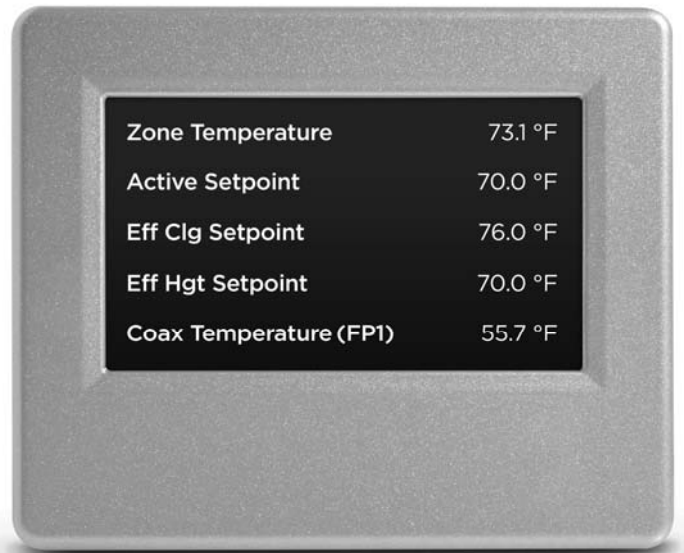

Controls - UPC DDC Control (optional) cont.

1. Leaving Air Temperature (LAT) Sensor - This 10 kOhm NTC sensor is factory installed on all UPC equipped heat pumps. It typically is attached to wiring inside the blower cabinet on the suction side of the blower. This sensor is attached on ABC FP2 pins available as LAT AU-30.

1. Compressor Proving Sensors - This optional factory installed current sensor is connected to confirm compressor operation via the power wires. The sensor is attached at ABC Y1 and available at point BV-65.

1. Valve End Switch - This optional input is setup for a field installed flow valve end switch. This end switch input is attached at ABC Y2 and available at point BV-67.

1. Fan Proving Sensors - This optional factory installed current sensor is connected to confirm fan operation via the power wires. The sensor is attached at ABC G and available at point BV-33.

1. Occupancy Sensor - This standard feature includes a field installed and wired room sensor with occupancy sensor typically found in DDC systems. The RNet room sensors can be found thru your commercial representative. The occupancy Sensors are attached at ABC O and can be found at point BV-49.

1. Dirty Filter Switch - This optional field installed switch is connected to confirm dirty filter operation. The dirty filter switch can be found thru your commercial representative. The sensor is attached at ABC W and available at point BV-63.

2. Fault, Configuration, and Status Codes - The codes can be visible to the BAS if desired

Aurora Base Fault Codes (ABC Only)

Fault LED (LED1, Red)

	Red Fault LED	LED Flash Code*	Lockout	Reset/Remove
ABC Basic Faults	Normal - No Faults	OFF	-	
	Fault - Input	1	No	Auto
	Fault - High Pressure	2	Yes	Hard or Soft
	Fault - Low Pressure	3	Yes	Hard or Soft
	Fault - Freeze Detection FP2	4	Yes	Hard or Soft
	Fault - Freeze Detection FP1	5	Yes	Hard or Soft
	Fault - Condensate Overflow	7	Yes	Hard or Soft
	Fault - Over/Under Voltage	8	No	Auto
	Fault - FP1 & FP2 Sensor Error	11	Yes	Hard or Soft

NOTE: All codes >11 use long flash for tens digit and short flash for the ones digit. 20, 30, 40, 50, etc. are skipped.

Aurora Advanced Fault Codes (ABC + AXB Expansion Board)

Fault LED (LED1, Red)

	Red Fault LED	LED Flash Code *	Lockout	Reset/Remove	Fault Condition Summary
ABC Basic Faults	Normal - No Faults	Off	-		
	Fault-Input	1	No	Auto	Tstat input error. Autoreset upon condition removal.
	Fault-High Pressure	2	Yes	Hard or Soft	HP switch has tripped (>600 psi)
	Fault-Low Pressure	3	Yes	Hard or Soft	Low Pressure Switch has tripped (<40 psi for 30 continuous sec.)
	Fault-Freeze Detection FP2	4	Yes	Hard or Soft	Freeze protection sensor has tripped (<15 or 30 degF for 30 continuous sec.)
	Fault-Freeze Detection FP1	5	Yes	Hard or Soft	Freeze protection sensor has tripped (<15 or 30 degF for 30 continuous sec.)
	Fault-Condensate Overflow	7	Yes	Hard or Soft	Condensate switch has shown continuity for 30 continuous sec.
	Fault-Over/Under Voltage	8	No	Auto	Instantaneous voltage is out of range. **Controls shut down until resolved.
ABC & AXB Advanced Faults	Fault-FP1 & 2 Snsr Error	11	Yes	Hard or Soft	If FP1 or 2 Sensor Error
	Fault-Compressor Monitor	10	Yes	Hard or Soft	Open Crkt, Run, Start or welded cont
	Non-CriticAXBSnsrErr	13	No	Auto	Any Other Sensor Error
	CriticAXBSnsrErr	14	Yes	Hard or Soft	Sensor Error for EEV or HW
	Alert-HotWtr	15	No	Auto	HW over limit or logic lockout. HW pump deactivated.
	Fault-VarSpdPump	16	No	Auto	Alert is read from PWM feedback.
	Not Used	17	No	Auto	I22 Com Fault. Autoreset upon condition removal.
	Non-CritComErr	18	No	Auto	Any non-critical com error
	Fault-CritComErr	19	No	Auto	Any critical com error. Auto reset upon condition removal
	Alarm - Low Loop Pressure	21	No	Auto	Loop pressure is below 3 psi for more than 3 minutes
	Alarm - Home Automation 1	23	No	Auto	Closed contact input is present on Dig 2 input - Text is configurable
	Alarm - Home Automation 2	24	No	Auto	Closed contact input is present on Dig 3 input - Text is configurable

NOTES:

*All codes >11 use long flash for tens digit and short flash for the ones digit. 20, 30, 40, 50 etc. are skipped!

Alert' is a noncritical sensor or function that has failed. Normal operation of the heat pump is maintained but service is desired at some point.

Controls - UPC DDC Control (optional) cont.

Aurora Base or Advanced Control Configuration and Status Codes

Status LED (LED3, Green)

Description of Operation	Fault LED, Green
Normal Mode	ON
Control is Non-functional	OFF
Test Mode	Slow Flash
Lockout Active	Fast Flash
Dehumidification Mode	Flash Code 2
Load Shed	Flash Code 5
Emergency Shutdown	Flash Code 6
On Peak Mode	Flash Code 7
(Future Use)	Flash Code 8
(Future Use)	Flash Code 9

Configuration LED (LED2, Yellow)

Description of Operation	Configuration LED, Yellow
No Software Overwritten	ECM Setting
DIP Switch Overwritten	Slow Flash
ECM Configuration Mode	Fast Flash
Reset Configuration Mode	OFF

9. Alarm Relay - The Alarm relay (ALM) is factory connected to 24 VAC via jumper JW2. By cutting JW2, ABC ALM becomes a dry contact connected to ABC ALG. The Relay is field switchable between Factory setting as an Alarm output or available for other uses.

10. Accessory Relay1 - A configurable, accessory relay on the ABC is provided that can be cycled with the compressor, blower, or the Dehumidifier (DH) input. A third (factory) setting cycles the relay with the compressor but delays the compressor and blower output for 90 sec. Source pump or slow opening solenoid valves in well systems or variable speed primary pumping systems would be a prime use of this feature.

Access Relay Operation	SW2-4	SW2-5
Cycle with Blower	ON	ON
Cycle with Compressor	OFF	OFF
Water Valve Slow Opening	ON	OFF
Cycle with Comm. T-stat Hum Cmd	OFF	ON

11. Electric Heat EH1 - A digital 24VDC output is provided for electric heat powering. UPC's Default programming has EH1 set for AUX/ELEC Heat operation and will be controlled using the UPC's internal P.I.D. logic. However it can be changed by the BAS to be network controlled.

12. Electric Heat EH2 - A digital VDC output is provided for field options converted from the original EH2 output. Default UPC program has the EH2 output set for Network Control but can be changed by the BAS to be controlled by the UPC's internal P.I.D. logic.

Controls - UPC DDC Control (optional) cont.

Aurora Advanced Control Configuration and Options (Future Availability on Select Models/Configurations)

1. **Accessory Relay2** - A second, configurable, accessory relay on the AXB is provided that can be cycled with the compressor 1 or 2, blower, or the Dehumidifier (DH) input. This is to complement the Accessory 1 Relay on the ABC board.

Position	DIP 4	DIP 5	Description
1	ON	ON	Cycles with Fan or ECM (or G)
2	OFF	ON	Cycles with CC1 first stage of compressor or compressor spd 1-12
3	ON	OFF	Cycles with CC2 second stage of compressor or compressor spd 7-12
4	OFF	OFF	Cycles with DH input from ABC board

2. **Analog Out** - A standard 0-10VDC analog output is provided. This output can be used to drive modulating dampers etc.
3. **Variable Speed Pump or Modulating Water Valve** - This input and output are provided to drive and monitor a variable speed pump. The VS pump output is a PWM signal to drive the variable speed pump. The minimum and maximum level are set using the AID Tool. 75% and 100% are the default settings respectively. The VS data input allows a separate PWM signal to return from the pump giving fault and performance information. Fault received from the variable speed pump will be displayed as E16. **Modulating Water Valve** - This Variable speed PWM output is provided to optionally drive a modulating water valve. Through advanced design a 0-10VDC valve can be driven directly from the VS pump output. The minimum and maximum level are set in the same way as the VS pump using the AID Tool. 75% and 100% are the default settings respectively.
4. **Loop Pump Slaving** - This input and output are provided so that two units can be slaved together with a common flow center. When either unit has a call for loop pump, both unit's loop pump relays and variable speed pumps are energized. The flow center then can simply be wired to either unit. The output from one unit should be routed to the input of the other. If daisy chained up to 16 heat pumps can be wired and slaved together in this fashion.

Controls - UPC DDC Control (optional) cont.

Aurora Advanced Control Optional Sensor Kits (Future Availability on Select Models/Configurations)

1. **Energy Monitoring (Standard Sensor Kit on 'Advanced' models)** - The Energy Monitoring Kit includes two current transducers (blower and electric heat) added to the existing two compressor sensors so that the complete power usage of the heat pump can be measured. The BACview Tool provides configuration detail for the type of blower motor and a line voltage calibration procedure to improve the accuracy. This real time power usage information can be displayed on the AID Tool and is available thru network points when using BACnet or N2 Open.
 - Compressor Current 1
 - Compressor Current 2
 - Fan Current
 - Aux Heat Current
 - Pump Selection
 - Voltage
 - Compressor Watts
 - Fan Watts
 - Aux Heat Watts
 - Pump Watts (VS Only)
2. **Refrigerant Monitoring (optional sensor kit)** - The optional Refrigerant Monitoring Kit includes two pressure transducers, and three temperature sensors, heating liquid line, suction temperature and existing cooling liquid line (FP1). These sensors allow the measurement of discharge and suction pressures, suction and liquid line temperatures as well as superheat and subcooling. This information can be displayed on the BACview Tool, or the network when using BACnet and N2.
 - Htg Liquid Line
 - Clg Liquid Line
 - Discharge pressure
 - Suction Pressure
 - Discharge Saturated Temp
 - Suction Saturated Temperature
 - Superheat
 - SubCooling
3. **Performance Monitoring (optional sensor kit)** - The optional Performance Monitoring Kit includes: three temperature sensors, entering and leaving water, leaving air temperature and a water flow rate sensor. With this kit, heat of extraction and rejection will be calculated. This requires configuration using the BACview Tool for selection of water or antifreeze.
 - Leaving Air Temperature (supply)
 - Alt Leaving Air Temperature (Supply)
 - Entering Water Temperature
 - Leaving Water Temperature
 - Water Flow Meter
 - Entering Air Temperature (from zone sensor)
 - Brine Selection (water/antifreeze)
 - Heat of Extraction/Rejection

Controls - UPC DDC Control (optional) cont.

ZS Series RNet Sensor Overview

The ZS Series line of intelligent zone sensors provides the function and flexibility you need to manage the conditions important to the comfort and productivity of the zone occupants. The ZS sensors are available in a variety of zone sensing combinations to address your application needs. These combinations include temperature, relative humidity, and indoor air quality (carbon dioxide or VOCs (Volatile Organic Compounds)). They are built to be flexible allowing for easy customization of what the user/technician sees. Designed to work with the Aurora UPC controllers the ZS sensor line includes the ZS Base, ZS Plus, ZS Pro and ZS Pro-F.

The UPC uses a proprietary communication called Rnet to receive the space temperature from the zone sensor.

This is done using (2) 18 AWG twisted pair unshielded cables for a total of 4 wires connected to the Rnet port. The sensor gets its power from the UPC controller and connecting multiple sensors to one UPC will allow for space temperature averaging. The UPC can support one ZS Pro or ZS Pro F with up to four ZS standard sensors wired to the Rnet port on the UPC for a total of 5 zone sensors. The sensors use a precise 10k ohm thermistor with less than 0.18°F drift over a ten year span, this allows for less maintenance or re-calibration after installation. The sensors also have a hidden communication port for connecting a BACview or local laptop that provides access to the equipment for commissioning and maintenance. The table below shows the features of each of the four sensors that are currently available.

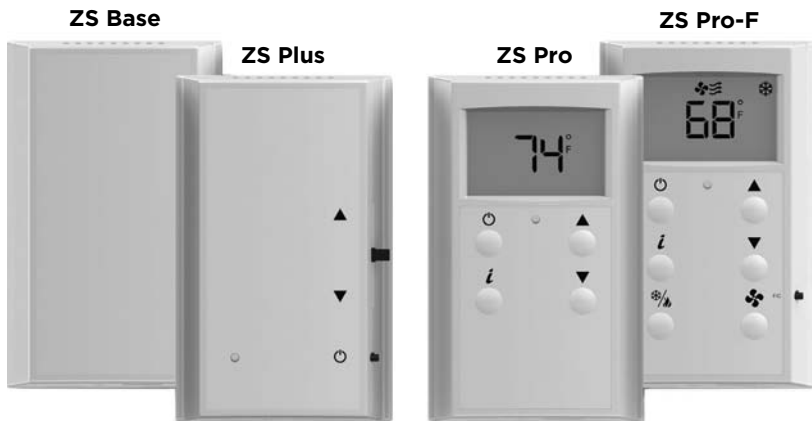

Features	ZS Base	ZS Plus	ZS Pro	ZS Pro-F
Temp, CO ² , Humidity, and VOC Options	✓	✓	✓	✓
Neutral Color	✓	✓	✓	✓
Addressable/supports daisy chaining	✓	✓	✓	✓
Hidden communication port	✓	✓	✓	✓
Mounts on a standard 2" by 4" electrical box	✓	✓	✓	✓
Occupancy Status indicator LED		✓	✓	✓
Push button occupancy override		✓	✓	✓
Setpoint adjust		✓	✓	✓
Large, easy to read LCD			✓	✓
Alarm indicator			✓	✓
°F to °C conversion button				✓

Options	Part Number	Part Number	Part Number	Part Number
Temperature Only	ZSU	ZSUPL	ZSUP	ZSUPF
Temp with CO ²	ZSU-C	ZSUPL-C	ZSUP-C	ZSUPF-C
Temp with Humidity	ZSU-H	ZSUPL-H	ZSUP-H	ZSUPF-H
Temp with Humidity, CO ²	ZSU-HC	ZSUPL-HC	ZSUP-HC	ZSUPF-HC
Temp, Humidity, VOC	ZSU-HV	ZSUPL-HV	ZSUP-HV	ZSUPF-HV
Temp with VOC	ZSU-V	ZSUPL-V	ZSUP-V	ZSUPF-V

Controls - UPC DDC Control (optional) cont.

RNet Sensor Physical and Electrical Data

Sensing Element	Range	Accuracy
Temperature (on non-Humidity models)	-4° to 122° F (-20° C to 50° C)	30.35° F (0.2° C)
Temperature (on Humidity models)	50° F to 104° F (10° C to 40° C)	30.5° F (0.3° C)
Humidity	10% to 90%	31.8% typical
CO2	400 to 1250 PPM 1250 to 2000 PPM	330PPM or +/-3% of reading (greater of two) 35% of reading plus 30 PPM
VOC	0 to 2,000 PPM	3100 PPM
Power Requirements	Sensor Type	Power Required
Temperature Only	All Models	12 Vdc @ 8 mA
Temperature with Humidity	All Models	12 Vdc @ 15 mA (idle) to 190 mA (CO2 measurement cycle)
Temp with VOC, or Temp/VOC/Humidity	All Models	12 Vdc @ 60 mA
Temp with CO2 , or Temp/ CO2/Humidity	All Models	12 Vdc @ 15 mA (idle) to 190 mA (CO2 measurement cycle)
Power Supply	A controller supplies the Rnet sensor network with 12 Vdc @ 210 mA. Additional power may be required for your application. See sensor ZS Installation Guide	
Communication	115 kbps Rnet connection between sensor(s) and controller 15 sensors max per Rnet network; 5 sensors max per control program	
Local Access Port	For connecting a laptop computer to the local equipment for maintenance and commissioning	
Environmental Operating Range	32° to 122° F (0° - 50° C), 10% to 90% relative humidity, non-condensing	
Mounting Dimensions	Standard 4"x 2" electrical box using provided 6/32" x 1/2" mounting screws	

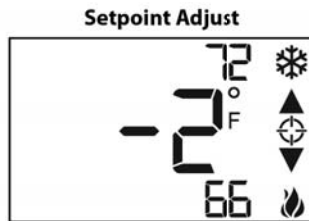
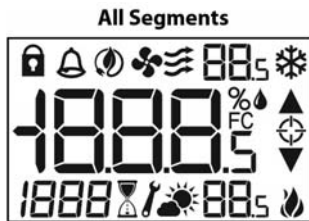

Temperature Only or Temperature with Humidity

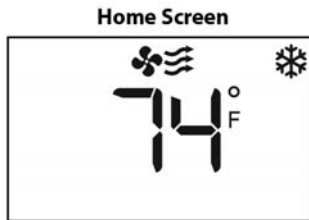
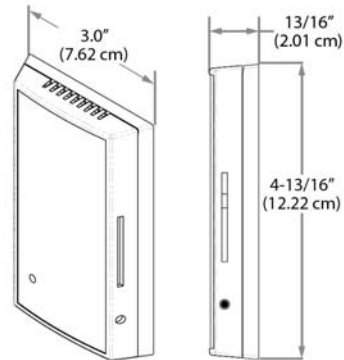

Sensor with CO₂ or VOC

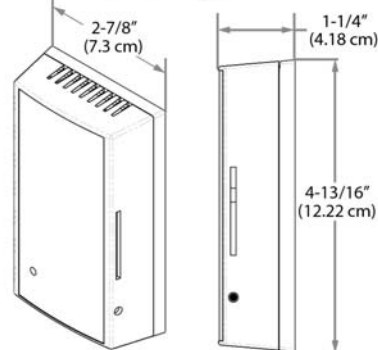

Unit Startup

Before Powering Unit, Check The Following:

NOTE: Remove and discard the compressor shipping bolts. The bolts can then be discarded.

- High voltage is correct and matches nameplate.
- Fuses, breakers and wire size correct.
- Low voltage wiring complete.
- Piping completed and water system cleaned and flushed.
- Air is purged from closed loop system.
- Isolation valves are open, water control valves or loop pumps wired.
- Condensate line open and correctly pitched.
- Transformer switched to 208V if applicable.
- Dip switches are set correctly.
- Blower rotates freely – foam shipping support has been removed.
- Blower speed correct.
- Air filter/cleaner is clean and in position.
- Service/access panels are in place.
- Return air temperature is between 50-80°F heating and 60-95°F cooling.
- Check air coil cleanliness to insure optimum performance. Clean as needed according to maintenance guidelines. To obtain maximum performance the air coil should be cleaned before startup. A 10-percent solution of dishwasher detergent and water is recommended for both sides of coil, a thorough water rinse should follow.

Startup Steps

NOTE: Complete the Equipment Start-Up/Commissioning Check Sheet during this procedure. Refer to thermostat operating instructions and complete the startup procedure.

1. Initiate a control signal to energize the blower motor. Check blower operation.
2. Initiate a control signal to place the unit in the cooling mode. Cooling setpoint must be set below room temperature.
3. Cooling will energize after a time delay. Check for correct rotation of scroll compressors in 3 phase applications. Incorrect rotation will cause low refrigerant pressures and possibly unusual noise. Switch any two power leads at the compressor or contactor to reverse rotation.
4. Be sure that the compressor and water control valve or loop pump(s) are activated.
5. Verify that the water flow rate is correct by measuring the pressure drop through the heat exchanger using the P/T plugs and comparing to the pressure drop table.
6. Check the temperature of both the supply and discharge water (Refer to Operating Parameters tables).
7. Check for an air temperature drop of 15°F to 25°F across the air coil, depending on the blower speed and entering water temperature.
8. Decrease the cooling set point several degrees and verify high-speed blower operation (variable speed ECM only).
9. Adjust the cooling setpoint above the room temperature and verify that the compressor and water valve or loop pumps deactivate.
10. Initiate a control signal to place the unit in the heating mode. Heating set point must be set above room temperature.
11. Heating will energize after a time delay.
12. Check the temperature of both the supply and discharge water (Refer to Unit Operating Parameters tables).
13. Check for an air temperature rise of 20°F to 35°F across the air coil, depending on the blower speed and entering water temperature.
14. If auxiliary electric heaters are installed, increase the heating setpoint until the electric heat banks are sequenced on. All stages of the auxiliary heater should be sequenced on when the thermostat is in the Emergency Heat mode. Check amperage of each element.
15. Adjust the heating setpoint below room temperature and verify that the compressor and water valve or loop pumps deactivate.
16. During all testing, check for excessive vibration, noise or water leaks. Correct or repair as required.
17. Set system to desired normal operating mode and set temperature to maintain desired comfort level.
18. Instruct the owner/operator in the proper operation of the thermostat and system maintenance.

NOTE: Be certain to fill out and forward all warranty registration papers.

Operating Parameters

Entering Water Temp °F	Water Flow gpm/ton	Cooling					
		Suction Pressure psig	Discharge Pressure psig	Superheat	Subcooling	Water Temp Rise °F	Air Temp Drop °F DB
30	1.5	100-115	170-190	17 - 26	10 - 14	18 - 22	18 - 22
	3.0	95-110	150-170	20 - 29	7 - 11	8 - 10	18 - 22
50	1.5	133 - 148	205 - 225	17 - 26	10 - 14	18 - 22	18 - 22
	3.0	129 - 144	185 - 205	20 - 29	7 - 11	8 - 10	18 - 22
70	1.5	139 - 154	280 - 300	8 - 11	8 -12	18 - 22	18 - 22
	3.0	137 - 152	250 - 270	9 - 12	7 - 11	8 - 10	18 - 22
90	1.5	143 - 158	360 - 380	8 - 11	9 - 13	18 - 22	16 - 20
	3.0	141 - 156	330 - 350	9 - 12	8 - 12	8 - 10	16 - 20
110	2.3	143 - 158	360 - 380	8 - 11	9 - 13	18 - 22	16 - 20
	3.0	141 - 156	440-460	9 - 12	8 - 12	8 - 10	16 - 20

Entering Water Temp °F	Water Flow gpm/ton	Heating					
		Suction Pressure psig	Discharge Pressure psig	Superheat	Subcooling	Water Temp Drop °F	Air Temp Rise °F DB
30	1.5	73 - 79	279 - 304	7 - 13	2 - 6	7 -10	18 - 24
	3.0	79 - 85	285 - 310	8 - 14	2 - 6	3 - 6	20 - 26
50	1.5	103 - 109	308 - 333	8 - 12	4 - 8	8 - 11	20 - 26
	3.0	110 - 116	315 - 340	9 - 13	4 - 8	4 - 7	22 - 28
70	1.5	140 - 146	330 - 365	10 - 14	7 - 11	11 - 14	26 - 32
	3.0	146 - 153	340 - 375	10 - 14	7 - 11	7 - 10	28 - 34
90	1.5	170-177	425-460	14-18	12-16	8-11	42-50
	3.0	174-181	435-470	14-18	12-16	8-11	42-50
110	2.3						
	3.0						

NOTES: Cooling performance based on entering air temperatures of 80°F DB, 67°F WB.
 Heating performance based on entering air temperature of 70°F DB.

5/1/11

Operating Limits

Operating Limits	Cooling		Heating	
	(°F)	(°C)	(°F)	(°C)
Air Limits				
Min. Ambient Air	45	7.2	45	7.2
Rated Ambient Air	80	26.7	70	21.1
Max. Ambient Air	100	37.8	85	29.4
Min. Entering Air	50	10.0	40	4.4
Rated Entering Air db/wb	80.6/66.2	27/19	68	20.0
Max. Entering Air db/wb	110/83	43/28.3	80	26.7
Water Limits				
Min. Entering Water	30	-1.1	20	-6.7
Normal Entering Water	50-110	10-43.3	30-70	-1.1
Max. Entering Water	120	48.9	90	32.2

NOTE: Minimum/maximum limits are only for start-up conditions, and are meant for bringing the space up to occupancy temperature. Units are not designed to operate at the minimum/maximum conditions on a regular basis. The operating limits are dependent upon three primary factors: 1) water temperature, 2) return air temperature, and 3) ambient temperature. When any of the factors are at the minimum or maximum levels, the other two factors must be at the normal level for proper and reliable unit operation.

Pressure Drop

Model	GPM	Pressure Drop (psi)				
		30°F	50°F	70°F	90°F	110°F
006	1.0	1.2	1.2	1.1	1.0	1.0
	1.5	2.2	2.0	1.9	1.8	1.7
	2.0	3.3	3.1	2.9	2.7	2.5
	2.5	4.1	3.8	3.4	3.1	2.9
009	1.5	1.9	1.7	1.5	1.3	1.1
	2.0	3.0	2.8	2.6	2.4	2.2
	3.0	6.3	6.3	6.1	5.9	5.7
	4.0	8.1	7.9	7.4	6.8	6.1
012	1.5	1.1	1.1	1.0	0.9	0.9
	2.5	2.4	2.3	2.2	2.0	1.9
	3.5	4.2	4.0	3.7	3.4	3.2
	4.5	6.1	5.9	5.2	4.7	4.1
015	2.0	1.8	1.7	1.6	1.4	1.2
	3.0	3.3	3.1	2.9	2.6	2.3
	4.0	5.0	4.9	4.8	4.7	4.6
	5.0	7.1	6.7	5.9	5.4	5.1
018	3.0	3.3	3.2	3.0	2.8	2.6
	4.0	4.7	4.2	3.9	3.6	3.1
	5.0	6.2	5.2	4.7	4.1	3.5
	6.0	7.7	6.2	5.4	4.6	3.8
024	3.0	3.2	3.1	2.9	2.7	2.5
	4.5	6.1	5.5	4.9	4.5	4.2
	6.0	9.0	7.9	6.9	6.3	5.8
	8.0	12.9	10.9	9.5	8.8	7.9
030	4.0	2.4	2.3	2.2	2.0	1.8
	6.0	5.1	4.9	4.7	4.5	4.3
	8.0	7.8	7.5	7.1	6.9	6.7
	10.0	10.5	10.1	9.6	9.3	8.9
036	5.0	2.0	1.9	1.7	1.5	1.4
	7.0	3.6	3.5	3.3	3.1	2.9
	9.0	5.2	5.1	4.8	4.6	4.4
	12.0	7.5	7.4	7.1	6.9	6.7
042	5.0	2.1	2.0	1.8	1.6	1.4
	8.0	4.8	4.7	4.5	4.4	4.2
	11.0	7.5	7.4	7.0	6.6	6.1
	14.0	10.1	9.9	9.6	8.8	8.1
048	6.0	2.7	2.6	2.4	2.2	2.0
	9.0	6.0	5.9	5.4	5.2	5.1
	12.0	9.5	9.3	8.5	8.3	8.1
	16.0	14.2	13.9	12.7	12.3	12.1
060	9.0	4.5	4.4	4.2	4.0	3.8
	12.0	6.5	6.3	6.1	5.9	5.7
	15.0	8.6	8.1	7.9	7.7	7.5
	20.0	12.1	11.2	10.8	10.6	10.4
070	12.0	5.7	5.6	5.4	5.2	5.0
	15.0	8.9	8.6	8.2	7.7	6.7
	18.0	12.0	11.5	11.0	10.1	8.4
	24.0	17.4	16.9	16.5	15.1	11.8

9/5/12

Valve	GPM	Cv	Pressure Drop (psi)
Internally mounted 2-position solenoid water valves are not available on models 006-012			
1/2"	3.0	9.9	0.09
	4.0	10.1	0.16
	5.0	10.4	0.23
	6.0	10.6	0.32
1/2"	3.0	9.9	0.09
	4.0	10.1	0.16
	5.0	10.4	0.23
	6.0	10.6	0.32
3/4"	3.0	9.9	0.09
	4.5	10.2	0.19
	6.0	10.6	0.32
	8.0	11.0	0.53
3/4"	4.0	10.1	0.16
	6.0	10.6	0.32
	8.0	11.0	0.53
	10.0	11.5	0.76
3/4"	5.0	10.4	0.23
	7.0	10.8	0.42
	9.0	11.2	0.64
	12.0	11.9	1.02
3/4"	5.0	10.4	0.23
	8.0	11.0	0.53
	11.0	11.7	0.89
	14.0	12.3	1.29
3/4"	6.0	10.6	0.32
	9.0	11.2	0.64
	12.0	11.9	1.02
	16.0	12.8	1.57
1"	9.0	16.8	0.29
	12.0	17.4	0.47
	15.0	18.1	0.69
	20.0	19.2	1.09
1"	12.0	17.4	0.47
	15.0	18.1	0.69
	18.0	18.7	0.92
	24.0	20.1	1.43

9/5/12

Compressor and Thermistor Resistance

Compressor Resistance

Model	115/60/1		208-230/60/1		265/60/1		208-230/60/3	460/60/3	575/60/4
	Run	Start	Run	Start	Run	Start			
006	1.25-1.43	2.70-3.10	5.30-6.09	5.12-5.89	8.33-9.59	4.25-4.89			
009	0.77-0.89	1.79-2.05	3.65-4.19	3.75-4.31	3.73-4.27	4.45-5.13			
012	Not Available at Time of Publication		3.35-3.85	2.80-3.22	3.73-4.27	4.45-5.13			
015			2.74-3.16	2.60-3.00	3.03-3.49	2.39-2.75			
018			2.24-2.58	2.84-3.26	3.03-3.49	2.39-2.75			
024			1.36-1.50	2.26-2.50	1.33-1.47	2.34-2.58	1.29-1.43	5.06-5.6	
030			0.93-1.03	1.64-1.82	1.33-1.47	2.34-2.58	1.29-1.43	5.06-5.6	
036			0.60-0.66	1.20-1.32	0.76-0.84	1.67-1.85	1.09-1.21	4.38-4.84	
042			0.49-0.55	1.56-1.73			1.09-1.21	4.38-4.84	6.88-7.60
048			0.51-0.57	1.58-1.74			0.88-0.97	3.41-3.77	5.39-5.96
060			0.43-0.48	1.33-1.47			0.88-0.97	2.78-3.07	5.39-5.96
070			0.35-0.40	1.34-1.54			0.71-0.81	2.72-3.13	4.27-4.92

09/26/12

Thermistor Resistance

Thermistor Temperature (°F)	Microprocessor Resistance (Ohms)
5	72,950
14	55,330
23	42,330
32	32,650
41	25,390
50	19,900
59	15,710
68	12,490
77	10,000
86	8,057
95	6,530
104	5,327
113	4,370
122	3,603
131	2,986
140	2,488
149	2,083

5/1/11

Refrigerant Circuit Guideline

Symptom	Head Pressure	Suction Pressure	Compressor Amp Draw	Superheat	Subcooling	Air Temp. Differential	Water Temp. Differential
Under Charged System (Possible Leak)	Low	Low	Low	High	Low	Low	Low
Over Charged System	High	High	High	Normal	High	Normal/Low	Normal
Low Air Flow Heating	High	High	High	High/Normal	Low	High	Low
Low Air Flow Cooling	Low	Low	Low	Low/Normal	High	High	Low
Low Water Flow Heating	Low/Normal	Low/Normal	Low	Low	High	Low	High
Low Water Flow Cooling	High	High	High	High	Low	Low	High
High Air Flow Heating	Low	Low	Low	Low	High	Low	Low
High Air Flow Cooling	Low	High	Normal	High	Low	Low	Normal
High Water Flow Heating	Normal	Low	Normal	High	Normal	Normal	Low
High Water Flow Cooling	Low	Low	Low	Low	High	Normal	Low
Low Indoor Air Temperature Heating	Low	Low	Low	Normal	High	Normal	Normal/High
Low Indoor Air Temperature Cooling	Low	Low	Low	Normal/Low	High	Low	Low
High Indoor Air Temperature Heating	High	High	High	Normal/High	Normal/Low	Low	Normal
High Indoor Air Temperature Cooling	High	High	High	High	Low	Low	High
Restricted TXV (Check Service Advisory)	High	Low	Normal/Low	High	High	Low	Low
Insufficient Compressor (Possible Bad Valves)	Low	High	Low	High	Normal/High	Low	Low
TXV - Bulb Loss of Charge	Low	Low	Low	High	High	Low	Low
Scaled Coaxial Heat Exchanger Heating	Low	Low	Low	Normal/Low	High	Low	Low
Scaled Coaxial Heat Exchanger Cooling	High	High	High	Normal/Low	Low	Low	Low
Restricted Filter Drier	Check temperature difference (delta T) across filter drier.						

7/6/10

Heat of Extraction/Rejection Data

Model	gpm	Heat Of Extraction (HE)				Heat of Rejection (HR)				
		30°F	50°F	70°F	90°F	30°F	50°F	70°F	90°F	110°F
006	1.0		4.6	6.0	7.5		10.2	9.2	13.5	
	1.5	3.6	4.7	6.1	7.7	9.8	10.1	9.3	13.3	8.2
	2.0	3.1	4.8	6.2	7.8	9.8	10.1	9.3	13.2	8.3
009	1.5		6.2	7.7	10.0		11.9	11.1	10.1	
	2.0	5.0	6.3	7.9	10.2	11.8	11.9	11.0	10.1	9.3
	3.0	4.8	6.5	8.2	10.4	11.9	12.0	10.9	10.2	9.4
012	1.5		8.0	9.9	13.3		15.2	14.6	13.6	
	2.5	6.6	8.4	10.4	13.5	14.6	15.1	14.7	13.6	11.6
	3.5	6.4	8.7	10.9	13.7	14.7	15.0	14.8	13.6	11.7
015	2.0		9.2	11.5	13.4		18.9	18.0	17.0	
	3.0	7.7	9.5	11.8	13.6	19.2	19.0	18.1	17.1	15.5
	4.0	7.2	9.9	12.1	13.8	19.3	19.1	18.2	17.2	15.6
018	3.0		11.4	14.6	16.2		25.4	24.0	22.7	
	4.0	9.2	11.7	14.7	16.5	25.2	25.1	23.6	22.7	21.7
	5.0	8.9	11.9	14.8	16.8	25.3	24.9	23.3	22.9	21.8
024	3.0		15.9	20.2	22.5		32.6	30.8	28.8	
	4.5	13.2	16.5	20.5	22.9	33.1	33.0	31.3	28.8	26.1
	6.0	11.9	17.2	20.8	23.3	33.3	33.4	31.7	29.1	26.3
030	4.0		19.9	25.4	31.0		39.9	37.4	34.8	
	6.0	16.1	20.7	26.5	31.5	39.0	40.3	37.7	34.8	31.4
	8.0	14.5	21.6	27.6	32.0	39.2	40.7	38.1	35.2	31.6
036	5.0		24.8	32.3	38.1		48.6	46.4	43.0	
	7.0	20.0	25.9	33.4	38.7	46.7	48.7	46.8	43.1	39.3
	9.0	18.4	27.0	34.6	39.3	46.9	48.8	47.1	43.5	39.6
042	5.0		28.1	37.3	47.4		57.0	52.9	68.6	
	8.0	22.8	29.9	39.0	48.2	54.7	57.6	53.4	68.7	44.9
	11.0	22.1	31.6	40.7	49.0	55.0	58.1	54.0	69.2	45.3
048	6.0		33.7	44.8	58.0		69.2	64.8	59.5	
	9.0	26.3	35.4	47.3	58.9	63.9	69.5	65.4	59.6	53.5
	12.0	25.9	37.1	49.8	59.9	64.2	69.7	66.0	60.1	53.9
060	9.0		36.7	47.2	60.6		78.1	73.7	68.6	
	12.0	28.8	38.0	49.9	61.6	74.0	78.4	74.1	68.7	62.2
	15.0	28.6	39.3	52.6	62.6	74.3	78.6	74.4	69.2	62.6
070	12.0		47.7	63.7	78.4		88.8	86.1	79.5	
	15.0	36.0	48.7	65.4	79.7	76.1	87.9	86.3	79.6	72.1
	18.0	34.5	49.6	67.1	81.0	76.4	87.1	86.5	80.3	72.6

Values displayed in MBtu/h

09/26/12

Reference Calculations

Heating Calculations:	Cooling Calculations:
$LWT = EWT - \frac{HE}{gpm \times 500}$	$LWT = EWT + \frac{HR}{gpm \times 500}$
$LAT = EAT + \frac{HC}{cfm \times 1.08}$	$LAT(DB) = EAT(DB) - \frac{SC}{cfm \times 1.08}$
$TH = HC + HWC$	$LC = TC - SC$
	$S/T = \frac{SC}{TC}$

Legend

ABBREVIATIONS AND DEFINITIONS:

cfm	=	airflow, cubic feet/minute
EWT	=	entering water temperature, Fahrenheit
gpm	=	water flow in gallons/minute
WPD	=	water pressure drop, PSI and feet of water
EAT	=	entering air temperature, Fahrenheit (dry bulb/wet bulb)
HC	=	air heating capacity, MBtu/h
TC	=	total cooling capacity, MBtu/h
SC	=	sensible cooling capacity, MBtu/h
KW	=	total power unit input, kilowatts
HR	=	total heat of rejection, MBtu/h
HE	=	total heat of extraction, MBtu/h
HWC	=	hot water generator capacity, MBtu/h
EER	=	Energy Efficient Ratio = BTU output/Watt input
COP	=	Coefficient of Performance = BTU output/BTU input
LWT	=	leaving water temperature, °F
LAT	=	leaving air temperature, °F
TH	=	total heating capacity, MBtu/h
LC	=	latent cooling capacity, MBtu/h
S/T	=	sensible to total cooling ratio

Troubleshooting

Should a major problem develop, refer to the following information for possible causes and corrective steps.

If compressor won't run:

1. The fuse may be open or the circuit breaker is tripped. Check electrical circuits and motor windings for shorts or grounds. Investigate for possible overloading. Replace fuse or reset circuit breakers after fault is corrected.
2. Supply voltage may be too low. Check it with a volt meter.
3. Control system may be faulty. Check control for correct wiring of thermostat or aquastat and check the 24 volt transformer for proper voltage.
4. Wires may be loose or broken. Replace or tighten.
5. The low pressure switch may have tripped due to one or more of the following:
 - a) Heating
 - 1) Plugged heat exchanger on source side
 - 2) Water flow source side - (Low)
 - 3) Water too cold source side
 - 4) Low refrigerant
 - b) Cooling
 - 1) Plugged heat exchanger on load side
 - 2) Water flow load side - (Low)
 - 3) Water too cold load side
 - 4) Low refrigerant
6. The high pressure switch may have tripped due to one or more of the following:
 - a) Heating
 - 1) Plugged heat exchanger on load side
 - 2) Low water flow load side
 - 3) Water too warm load side
 - b) Cooling
 - 1) Plugged heat exchanger on source side
 - 2) Low water flow on source side
 - 3) Water too warm source side
7. The compressor overload protection may be open.
8. The internal winding of the compressor motor may be grounded to the compressor shell. If so, replace the compressor.
9. The compressor winding may be open or shorted. Disconnect power. Check continuity with ohm meter. If the winding is open, replace the compressor.

If sufficient cooling or heating is not obtained:

1. Check control for improper location or setting.
2. Check for restriction in water flow.
3. Check refrigerant subcooling and superheat for proper refrigerant charge and expansion valve operation.
4. The reversing valve may be defective and creating a bypass of refrigerant. If the unit will not heat, check the reversing valve coil.

If the unit operation is noisy:

1. Check compressor for loosened mounting bolts. Make sure compressor is floating free on its isolator mounts. Check for tubing contact with the compressor or other surfaces. Readjust it by bending slightly.
2. Check screws on all panels.
3. Check for chattering or humming in the contactor or relays due to low voltage or a defective holding coil. Replace the component.
4. Check for proper installation of vibration absorbing material under the unit.
5. Check for abnormally high discharge pressures.
6. Compressor rotation incorrect

Refrigerant Systems

To maintain sealed circuit integrity, do not install service gauges unless unit operation appears abnormal. Compare the change in temperature on the air side as well as the water side to the Operating Parameters tables. If the unit's performance is not within the ranges listed, and the airflow and water flow are known to be correct, gauges should then be installed and superheat and subcooling numbers calculated. If superheat and subcooling are outside recommended ranges, an adjustment to the refrigerant charge may be necessary.

NOTE: Verify that air and water flow rates are at proper levels before servicing the refrigerant circuit.

Startup and Troubleshooting Form

Company Name: _____ Company Phone No: _____
 Technician Name: _____ Date: _____
 Model No: _____ Serial No: _____
 Owner's Name: _____ Open or Closed Loop: _____
 Installation Address: _____ Installation Date: _____

Check One

Start up/Check-out for new installation Troubleshooting Problem: _____

1. FLOW RATE IN GPM (COAXIAL HEAT EXCHANGER)

Water In Pressure: a. _____ PSI
 Water Out Pressure: b. _____ PSI
 Pressure Drop = a - b c. _____ PSI
 Convert Pressure Drop to Flow Rate
 (refer to *Pressure Drop* table) d. _____ GPM

2. TEMPERATURE RISE OR DROP ACROSS COAXIAL HEAT EXCHANGER

	COOLING	HEATING
Water In Temperature:	e. _____ °F	e. _____ °F
Water Out Temperature:	f. _____ °F	f. _____ °F
Temperature Difference:	g. _____ °F	g. _____ °F

3. TEMPERATURE RISE OR DROP ACROSS AIR COIL

	COOLING	HEATING
Air In Temperature:	h. _____ °F	h. _____ °F
Air Out Temperature:	i. _____ °F	i. _____ °F
Temperature Difference:	j. _____ °F	j. _____ °F

4. HEAT OF REJECTION (HR) / HEAT OF EXTRACTION (HE) CALCULATION

HR or HE = Flow Rate x Temperature Difference x Brine Factor*
 d. (above) x g. (above) x 485 for Methanol or Environol, 500 for water*
 Heat of Extraction (Heating Mode) = _____ btu/hr
 Heat of Rejection (Cooling Mode) = _____ btu/hr
 Compare results to Capacity Data Tables

Note: Steps 5 through 8 need only be completed if a problem is suspected

5. WATTS

	COOLING	HEATING
Volts:	m. _____ VOLTS	m. _____ VOLTS
Total Amps (Comp. + Fan):	n. _____ AMPS	n. _____ AMPS
Watts = m. x n. x 0.85	o. _____ WATTS	o. _____ WATTS

6. CAPACITY

Cooling Capacity = HR. - (o. x 3.413) p. _____ btu/hr
 Heating Capacity = HE. + (o. x 3.413) p. _____ btu/hr

7. EFFICIENCY

Cooling EER = p. / o. q. _____ EER
 Heating COP = p. / (o. x 3.413) q. _____ COP

8. SUPERHEAT (S.H.) / SUBCOOLING (S.C.)

	COOLING	HEATING
Suction Pressure:	r. _____ PSI	r. _____ PSI
Suction Saturation Temperature:	s. _____ °F	s. _____ °F
Suction Line Temperature:	t. _____ °F	t. _____ °F
Superheat = t. - s.	u. _____ °F	u. _____ °F
Head Pressure:	v. _____ PSI	v. _____ PSI
High Pressure Saturation Temp.:	w. _____ °F	w. _____ °F
Liquid Line Temperature*:	x. _____ °F	x. _____ °F
Subcooling = w. - x.	y. _____ °F	y. _____ °F

* Note: Liquid line is between the coaxial heat exchanger and the expansion valve in the cooling mode; between the air coil and the expansion valve in the heating mode.

DEALER: _____
 PHONE #: _____ DATE: _____
 PROBLEM: _____
 MODEL #: _____
 SERIAL #: _____



Startup/Troubleshooting Form

COOLING CYCLE ANALYSIS

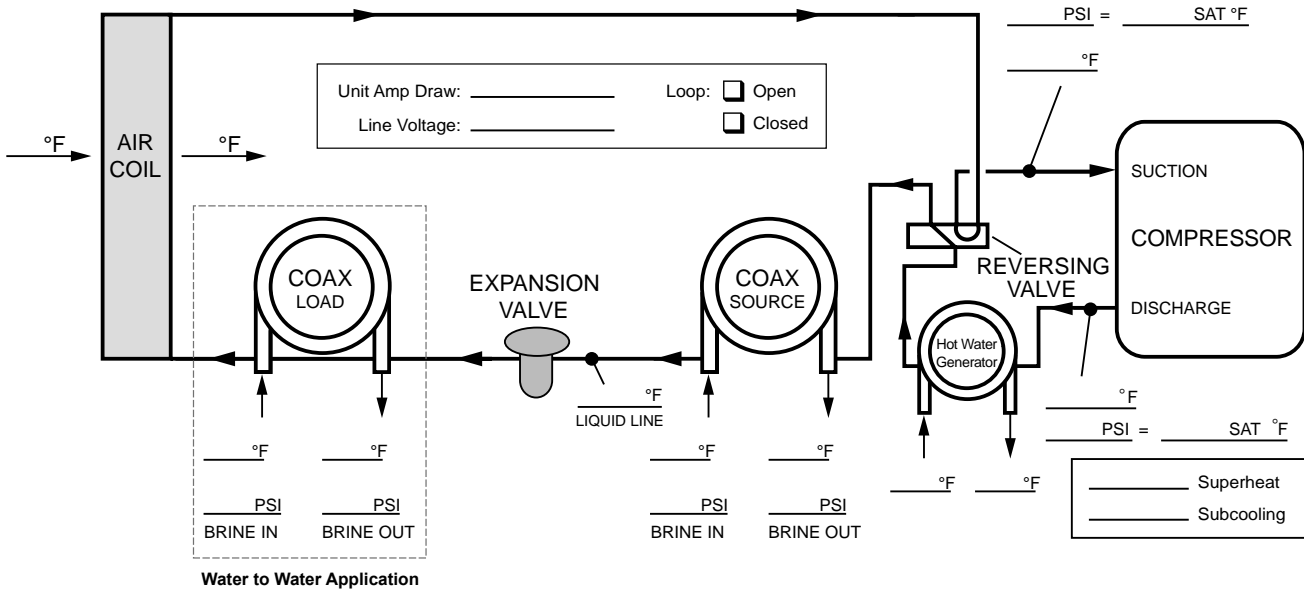

Heat of Extraction/Rejection = GPM x 500 (485 for water/antifreeze) x ΔT

Note: DO NOT hook up pressure gauges unless there appears to be a performance problem.

HEATING CYCLE ANALYSIS

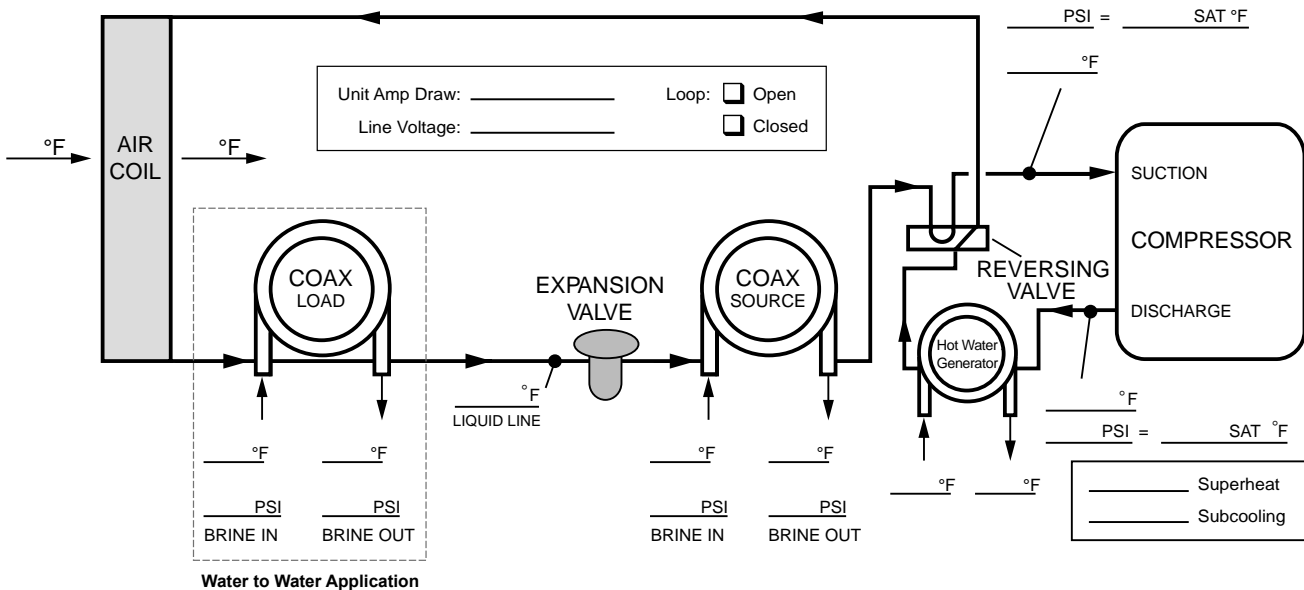

Preventive Maintenance

Water Coil Maintenance

1. Keep all air out of the water. An open loop system should be checked to ensure that the well head is not allowing air to infiltrate the water line. Lines should always be airtight.
2. Keep the system under pressure at all times. It is recommended in open loop systems that the water control valve be placed in the discharge line to prevent loss of pressure during off cycles. Closed loop systems must have positive static pressure.

NOTE: On open loop systems, if the installation is in an area with a known high mineral content (125 PPM or greater) in the water, it is best to establish with the owner a periodic maintenance schedule so the coil can be checked regularly. Should periodic coil cleaning be necessary, use standard coil cleaning procedures which are compatible with either the cupronickel or copper water lines. Generally, the more water flowing through the unit the less chance for scaling.

Other Maintenance

Filters

Filters must be clean to obtain maximum performance. They should be inspected monthly under normal operating conditions and be replaced when necessary. Units should never be operated without a filter.

Condensate Drain

In areas where airborne bacteria produce a slime in the drain pan, it may be necessary to treat chemically to minimize the problem. The condensate drain can pick up lint and dirt, especially with dirty filters. Inspect twice a year to avoid the possibility of overflow.

Blower Motors

Blower motors are equipped with sealed ball bearings and require no periodic oiling.

Air Coil

The air coil must be cleaned to obtain maximum performance. Check once a year under normal operating conditions and, if dirty, brush or vacuum (with a brush attachment) clean. Care must be taken not to damage the aluminum fins while cleaning.



CAUTION: Fin edges are sharp.

Replacement Procedures

Obtaining Parts

When ordering service or replacement parts, refer to the model number and serial number of the unit as stamped on the serial plate attached to the unit. If replacement parts are required, mention the date of installation of the unit and the date of failure, along with an explanation of the malfunctions and a description of the replacement parts required.

In-Warranty Material Return

Material may not be returned except by permission of authorized warranty personnel. Contact your local distributor for warranty return authorization and assistance.

Service Parts - Vertical

		006	009	012	015	018	024	030	036	042	048	060	070	
Compressor	Compressor 208-230/60/1	34P653-01	34P590-01	34P591-01	34P592-01	34P593-01	34P636-01	34P637-01	34P635-01	34P638-01	34P639-01	34P630-01	34P631-01	
	265/60/1	34P653-02	34P590-02	34P591-02	34P592-02	34P593-02	34P636-02	34P637-02	34P635-02	Not Available				
	230/60/3	Not Available					34P636-03	34P637-03	34P635-03	34P638-03	34P639-03	34P630-03	34P631-03	
	460/60/3	Not Available					34P636-04	34P637-04	34P635-04	34P638-04	34P639-04	34P630-04	34P631-04	
	575/60/3	Not Available								34P638-05	34P639-05	34P630-05	34P631-05	
	115/60/1	34P653-09	34P590-09	34P591-09	Not Available									
	Run Capacitor 208-230/60/1	16P002D12	16P002D17	16P002D18	16P002D19	16P002D19	16P002D20	16P002D21	16P002D32	16P002D23				
	Run Capacitor 265/60/1	16P002D27			16P002D30	16P002D29	16P002D30	Not Available						
	Run Capacitor 115/60/1	16P002D21	16P002D36		Not Available									
	Sound Jacket	92P504A01					92P523-01					92P524-01		
	Discharge Muffler	Not Available										36P503B02		
Variable Speed ECM Motor & Blower	VS ECM Motor 208-230/60/1	Not Available			14P515B01				14P516B01		14P517B01			
	VS ECM Motor 265/60/1	Not Available			14P515B03				Not Available					
	VS ECM Motor 230/60/3	Not Available					14P515B01		14P516B01		14P517B01			
	VS ECM Motor 460/60/3	Not Available					14P515B03		14P516B03		14P517B03			
	VS ECM Blower Housing	Not Available			53P512B01				53P515B01					
PSC Motor & Blower	PSC Motor 115/60/1	14P506-03		Not Available										
	PSC Motor 208-230/60/1	14P506-02		14P507B01	14P508B01	14P509B01	14P510B01	14P511B01	14P512B01	14P514B01				
	PSC Motor 265/60/1	14P506-02		14P507B02	14P508B02	14P509B02	14P510B02	Not Available						
	PSC Motor 230/60/3	Not Available					14P508B01	14P509B01	14P510B01	14P511B01	14P512B01	14P514B01		
	PSC Motor 460/60/3	Not Available					14P508B03	14P509B03	14P510B03	14P511B02	14P512B02	14P514B02		
	PSC Motor 575/60/3	Not Available								14P511B03	14P512B03	14P514B03		
	PSC Blower & Housing					53P512B01				53P517-02		53P515B01		
5-Speed ECM Motor & Blower	5-Speed ECM Motor 208-230/60/1	Not Available			14S536-18	14S536-01	14S536-02	14S536-03	14S537-01	14S537-02	14S537-03	14S537-03		
	5-Speed ECM Motor 277/60/1	Not Available			14S536-19	14S536-02	14S536-07	14S536-08	Not Available					
	5-Speed ECM Motor 230/60/3	Not Available					14P536-01	14S536-02	14S536-03	14S537-01	14S537-02	14S537-03	14S537-03	
	5-Speed ECM Motor 460/60/3	Not Available					14S536-03	14S536-10	14S536-11	14S537-04	14S537-05	14S537-06	14S537-06	
	5-Speed ECM Blower & Housing	Not Available			53P512B01				53P515B01					
Refrigeration Components	Air Coil	61P723-41			61P704-41		61P713-41		61P705-41	61P711-41		61P706-41	61P715-41	
	Coax (Copper)	62P587-01	62P591-01	62P586-01	62P586-01	62P586-01	62P572-01	62P566-01		62P568-01	62P573-01	62P574-01		
	TXV	33P605-19			33P605-16			33P605-02		33P605-10		33P608-10	33P605-13	
	Reversing Valve	33P502-05	33P502-05	33P502-05	33P505-04				33P506-04			33P503-05	33P526-04	
	Filter Drier	36P500B01										36P500B02		
Controls	Transformer 115/60/1	15P008B02			Not Available									
	Transformer 208-230/60/1	15P501B01												
	Transformer 265/60/1	15P507B01						Not Available						
	Transformer 230/60/3	Not Available					15P501B01							
	Transformer 460/60/3	Not Available					15P505B01							
	Transformer 575/60/3	Not Available								15P506B01				
	Phase Guard	Not Available					19P541A06							
Sensors & Safeties	High Pressure Switch	35P506B02												
	Low Pressure Switch	35P506B01												

Part numbers subject to change

8/19/13

Service Parts - Horizontal

		006	009	012	015	018	024	030	036	042	048	060	070	
Compressor	Compressor 208-230/60/1	34P653-01	34P590-01	34P591-01	34P592-01	34P593-01	34P636-01	34P637-01	34P635-01	34P638-01	34P639-01	34P630-01	34P631-01	
	265/60/1	34P653-02	34P590-02	34P591-02	34P592-02	34P593-02	34P636-02	34P637-02	34P635-02	Not Available				
	230/60/3	Not Available					34P636-03	34P637-03	34P635-03	34P638-03	34P639-03	34P630-03	34P631-03	
	460/60/3	Not Available					34P636-04	34P637-04	34P635-04	34P638-04	34P639-04	34P630-04	34P631-04	
	575/60/3	Not Available								34P638-05	34P639-05	34P630-05	34P631-05	
	115/60/1	34P653-09	34P590-09	34P591-09	Not Available									
	Run Capacitor 208-230/60/1	16P002D12	16P002D17	16P002D18	16P002D19	16P002D19	16P002D19	16P002D20	16P002D21	16P002D32	16P002D23			
	Run Capacitor 265/60/1	16P002D27			16P002D30	16P002D29	16P002D30	Not Available						
	Run Capacitor 115/60/1	16P002D21	16P002D36		Not Available									
	Sound Jacket	92P504A01					92P523-01					92P524-01		
	Discharge Muffler	Not Available										36P503B02		
	Variable Speed ECM Motor & Blower	VS ECM Motor 208-230/60/1	Not Available			14P515B01				14P516B01		14P517B01		
VS ECM Motor 265/60/1		Not Available			14P515B03				Not Available					
VS ECM Motor 230/60/3		Not Available					14P515B01		14P516B01		14P517B01			
VS ECM Motor 460/60/3		Not Available					14P515B03		14P516B03		14P517B03			
VS ECM Blower Housing		Not Available			53P512B01				53P515B01					
PSC Motor & Blower	PSC Motor 115/60/1	14P506-03			Not Available									
	PSC Motor 208-230/60/1	14P506-02			14P507B01	14P508B01	14P509B01	14P510B01	14P511B01	14P512B01	14P514B01			
	PSC Motor 265/60/1	14P506-02			14P507B02	14P508B02	14P509B02	14P510B02	Not Available					
	PSC Motor 230/60/3	Not Available					14P508B01	14P509B01	14P510B01	14P511B01	14P512B01	14P514B01		
	PSC Motor 460/60/3	Not Available					14P508B03	14P509B03	14P510B03	14P511B02	14P512B02	14P514B02		
	PSC Motor 575/60/3	Not Available								14P511B03	14P512B03	14P514B03		
	PSC Blower & Housing					53P512B01				53P517-02		53P515B01		
5-Speed ECM Motor & Blower	5-Speed ECM Motor 208-230/60/1	Not Available			14S536-18	14S536-01	14S536-02	14S536-03	14S537-01	14S537-02	14S537-03	14S537-03		
	5-Speed ECM Motor 277/60/1	Not Available			14S536-19	14S536-06	14S536-07	14S536-08	Not Available					
	5-Speed ECM Motor 230/60/3	Not Available					14P536-01	14S536-02	14S536-03	14S537-01	14S537-02	14S537-03	14S537-03	
	5-Speed ECM Motor 460/60/3	Not Available					14S536-09	14S536-10	14S536-11	14S537-04	14S537-05	14S537-06	14S537-06	
	5-Speed ECM Blower & Housing	Not Available			53P512B01				53P515B01					
Refrigeration Components	Air Coil	61P726-41	61P726-41	61P726-41	61P704-41		61P712-41		61P707-41	61P708-41		61P709-41	61P710-41	
	Coax (Copper)	62P587-01	62P591-01	62P586-01	62P586-01	62P586-01	62P586-01	62P572-01	62P566-01		62P568-01	62P573-01	62P574-01	
	TXV	33P605-19			33P605-16			33P605-02		33P605-10		33P608-10	33P605-13	
	Reversing Valve	33P502-05	33P502-05	33P502-05	33P505-04				33P506-04			33P503-05	33P526-04	
	Filter Drier	36P500B01										36P500B02		
Controls	Transformer 115/60/1	15P008B02			Not Available									
	Transformer 208-230/60/1	15P501B01												
	Transformer 265/60/1	15P507B01							Not Available					
	Transformer 230/60/3	Not Available					15P501B01							
	Transformer 460/60/3	Not Available					15P505B01							
	Transformer 575/60/3	Not Available								15P506B01				
	Phase Guard	Not Available					19P541A06							
Sensors & Safeties	High Pressure Switch	35P506B02												
	Low Pressure Switch	35P506B01												

Part numbers subject to change.

8/19/13

Notes

Revision Guide

Pages:	Description:	Date:	By:
All	Added CuproNickel Water Coil Option	20 May 2014	DS
All	Updated with New Aurora UPC DDC Controls	20 May 2014	DS
4	Corrected Nomenclature Error	23 Oct 2013	DS
All	Updated Series with New All-Aluminum Air Coils	09 Oct 2013	DS
16-19	Updated Aurora Controls Description	04 Mar 2013	DS
All	Updated Nomenclature to Reflect New Variable Speed ECM Blower	12 Nov 2012	DS
All	Added 006 - 015 Models	30 Oct 2012	DS
55	Added Revision Guide	30 Oct 2012	DS



Manufactured by
WaterFurnace International, Inc.
9000 Conservation Way
Fort Wayne, IN 46809
www.waterfurnace.com

Product: **Versatec Base Series**
Type: Geothermal/Water Source Heat Pump
Size: Commercial 0.5-6 Ton
Document: Installation Manual

IM1201AUB 05/14