

INSTALLER: Leave this manual with the appliance.
CONSUMER: Retain this manual for future reference.

WARNING: If the information in these instructions is not followed exactly, a fire or explosion may result causing property damage, personal injury or death.

FOR YOUR SAFETY

Installation and service must be performed by a qualified installer, service agency or the gas supplier.

WHAT TO DO IF YOU SMELL GAS

- Do not try to light any appliance.
- Do not touch any electrical switch.
- Do not use any phone in your building.
- Immediately call your gas supplier from a neighbour's phone. Follow the gas supplier's instructions.
- If you cannot reach your gas supplier call the fire department.

Do not store or use gasoline or other flammable vapors and liquids in the vicinity of this or any other appliance.

This appliance may be installed in an aftermarket permanently located, manufactured home (USA only) or mobile home, where not prohibited by local codes.

This appliance is only for use with the type of gas indicated on the rating plate. This appliance is not convertible for use with other gases, unless a certified kit is used.

This appliance is suitable for installation in a bedroom or bed sitting room.



TOWN & COUNTRY
LUXURY FIREPLACES

SERIAL #

TC30 INSTALLATION AND OPERATING INSTRUCTIONS



MODEL TC30
SERIES D
MODULAR DIRECT VENT
FIREPLACE



Table of Contents

Caution	3	Wall Termination Venting Chart.....	21
Safety	3	Roof Termination Venting Chart.....	22
Important Note for the Commonwealth of Massachusetts	4	Roof Termination Venting	23
Fireplace Dimensions	5	Vent Terminal Clearance.....	25
Minimum Clearances to Combustible Material	5	Vent Terminal Minimum Clearances	25
Installation Requirements	6	Vent Pipe Sealant	26
Manufactured (Mobile) Home	6	Vent Restrictor Adjustment	27
Window Frame Removal.....	6	Wall Shield / Ceiling Firestop Thimble	28
Top Standoffs.....	7	Wall Termination Kit	28
Locating The Fireplace	7	Roof Termination Kit	28
Framing and Finishing	8	Vent Pipe Dimensions	29
TC30 Steel Stud Framing Kit.....	10	Vent Offset Chart.....	30
Adjustable Lintel	12	Firebox Panels Installation.....	31
Hearth Extension.....	13	Finishing Touch Trim Kit Instructions.....	32
Electrical.....	14	Lighting Instructions	33
Wall Switch and Remote Control	15	First Fire.....	34
Selecting Natural Vent and Power Vent Modes.....	15	Special Operator Note	34
Home Automation	16	Remote Control Operation.....	34
Gas Supply	17	Maintenance	40
Gas Pressure Check.....	17	TC30-D Replacement Parts	41
Venting.....	18	Replacement Parts – Valve Control System	42
Wall Termination Venting	18	Wiring Diagram.....	43
		Rating Label	44

DANGER

**HOT GLASS WILL CAUSE
BURNS.**

**DO NOT TOUCH GLASS UNTIL
COOLED.**

**NEVER ALLOW CHILDREN TO
TOUCH GLASS.**

A barrier designed to reduce the risk of burns from the hot viewing glass is provided with the appliance and shall be installed for the protection of children and other at-risk individuals.

Caution

FOR YOUR SAFETY - Do not install or operate your Town & Country fireplace without first reading and understanding this manual. Any installation or operational deviation from the following instructions voids the Town & Country Fireplaces™ Warranty and may prove hazardous.

This appliance and its individual shut off valve must be disconnected from gas supply piping system during any pressure testing of that system at test pressures in excess of 1/2 psig (3.5 kPa).

This appliance must be isolated from the gas supply piping system by closing its individual manual shut off valve during any pressure testing of the gas supply piping system at test pressures equal to or less than 1/2 psig (3.5 kPa).

Note: When lit for the first time, the appliance will emit a slight odour for a couple of hours. This is due to the curing of paints, sealants and lubricants used in the manufacturing process. This condition is temporary. Open doors and windows to ventilate area. Smoke and fumes caused by the curing process may cause discomfort to some individuals.

Do not use the fireplace if any part has been under water. Immediately call a qualified service technician to inspect the fireplace and to replace any part of the control system and any gas control which has been under water.



We recommend that our gas hearth products be installed and serviced by professionals who are certified in the United States by the National Fireplace Institute® (NFI) as NFI Gas Specialists

Safety

Due to high temperatures, this gas appliance should be located out of traffic and away from furniture and draperies.

Children and adults should be alerted to the hazards of high surface temperatures and should stay away to avoid burns or clothing ignition.

Young children should be carefully supervised when they are in the same room as the appliance. Toddlers, young children, and others may be susceptible to accidental contact burns. A physical barrier is recommended if there are at-risk individuals in the house. To restrict access to a fireplace or stove, install an adjustable safety gate to keep toddlers, young children, and other at-risk individuals out of the room and away from hot surfaces. Clothing or other flammable material should not be placed on or near the appliance.

Any grill, panel or door removed for servicing the unit must be replaced prior to operating. Failure to do so may create a hazardous condition.

Installation and repair should be done by a qualified service person. The appliance should be inspected before use and at least annually by a professional service person. More frequent cleaning may be required due to excessive lint from carpeting, bedding material, etc. It is imperative that control compartments, burners and circulating air passageways of the appliance be kept clean.

It is our policy that no responsibility is assumed by the Company or by any of its employees or representatives for any damages caused by an inoperable, inadequate, or unsafe condition which is the result, either directly or indirectly, of any improper operation or installation procedures.

This appliance must not be connected to a chimney flue serving a separate solid fuel burning appliance.

Important Note for the Commonwealth of Massachusetts:

From Massachusetts Rules and Regulations 248 CMR 5.08:

(a) For all side wall horizontally vented gas fuelled equipment installed in every dwelling, building or structure used in whole or in part for residential purposes, including those owned or operated by the Commonwealth and where the side wall exhaust vent termination is less than seven (7) feet above finished grade in the area of the venting, including but not limited to decks and porches, the following requirements shall be satisfied.

1. **INSTALLATION OF CARBON MONOXIDE DETECTORS.** At the time of installation of the side wall horizontal vented gas fuelled equipment, the installing plumber or gas fitter shall observe that a hard wired carbon monoxide detector with an alarm and battery back-up is installed on the floor level where the gas equipment is to be installed, in addition, the installing plumber or gas fitter shall observe that a battery operated or hard-wired carbon monoxide detector with an alarm is installed on each additional level of the dwelling, building or structure served by the side wall horizontal vented gas fuelled equipment. It shall be the responsibility of the property owner to secure the services of qualified licensed professionals for the installation of hard-wired carbon monoxide detectors.

a. In the event that the side wall horizontally vented gas fuelled equipment is installed in a crawl space or an attic, the hard-wired carbon monoxide detector with alarm and battery back-up may be installed on the next adjacent floor level.

b. In the event that the requirements of this subdivision cannot be met at the time of completion of installation, the owner shall have a period of thirty (30) days to comply with the above requirements; provided, however, that during said thirty (30) day period, a battery operated carbon monoxide detector with an alarm shall be installed.

2. **APPROVED CARBON MONOXIDE DETECTORS.** Each carbon monoxide detector as required in accordance with the above provisions shall comply with NFPA 720 and be ANSI/UL 2034 listed as IAS certified.

3. **SIGNAGE.** A metal or plastic identification plate shall be permanently mounted to the exterior of the building at a minimum height of eight (8) feet above grade directly in line with the exhaust vent terminal for the horizontally vented gas fuelled heating appliance or equipment. The sign shall read, in print size no less than one-half (1/2) inch in size, "GAS VENT DIRECTLY BELOW. KEEP CLEAR OF ALL OBSTRUCTIONS"

4. **INSPECTION.** The state or local gas inspector of the side wall horizontally vented gas fuelled equipment shall not approve the installation unless, upon inspection, the inspector observes carbon monoxide detectors and signage installed in accordance with the provisions of 248 CMR 5.089(2)(a) 1 through 4.

(b) **EXEMPTIONS.** The following equipment is exempt from 248 CMR 5.089(2)(a) 1 through 4.

1. The equipment listed in Chapter 10 entitled "Equipment Not Required To Be Vented" in the most current edition of NFPA 54 as adopted by the Board; and

2. Product Approved side wall horizontal vented gas fuelled equipment installed in a room or structure separate from the dwelling, building or structure used in whole or in part for residential purposes.

(c) **MANUFACTURER REQUIREMENTS – GAS EQUIPMENT VENTING SYSTEM PROVIDED.** When the manufacturer of Product Approved side wall horizontally vented gas equipment provides a venting system design or venting system components with the equipment, the instructions provided by the manufacturer for installation of the equipment and the venting system shall include:

1. Detailed instructions for the installation of the venting system design or the venting system components; and

2. A complete parts list for the venting system design or venting system.

(d) **MANUFACTURER REQUIREMENTS – GAS EQUIPMENT VENTING SYSTEM NOT PROVIDED.** When the manufacturer of a Product Approved side wall horizontally vented gas fuelled equipment does not provide the parts for venting the fuel gases, but identifies "special venting systems", the following requirements shall be satisfied by the manufacturer.

1. The referenced "special venting system" instructions shall be included with the appliance or equipment installation instructions; and

2. The "special venting systems" shall be Product Approved by the Board, and the instructions for that system shall include a parts list and detailed installation instructions.

(e) A copy of all installation instructions for all Product Approved side wall horizontally vented gas fuelled equipment, all venting instructions, all parts lists for venting instructions, and/or all venting design instructions shall remain with the appliance or equipment at the completion of the installation.

Fireplace Dimensions

Fig. #1

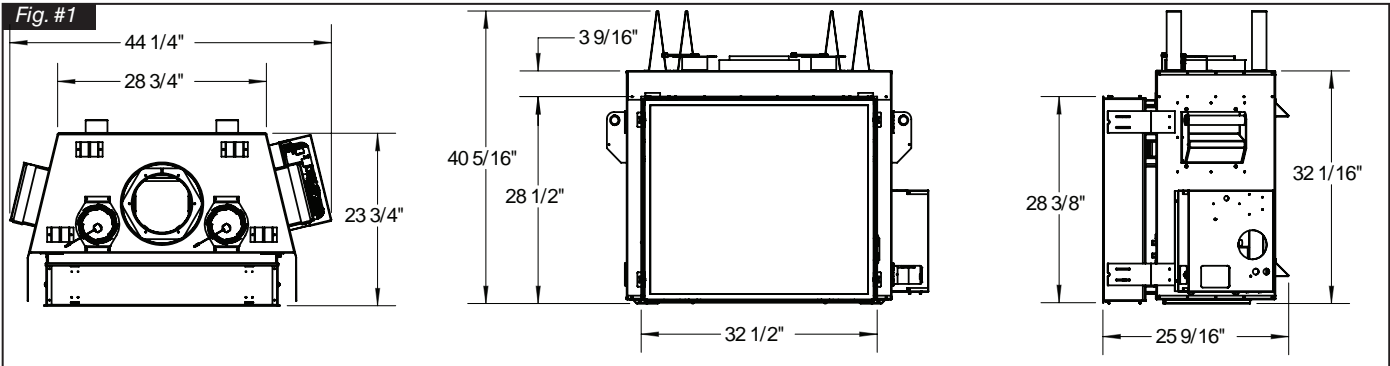

Minimum Clearances to Combustible Material

Fig. #2

COMBUSTIBLE FRAMING AND FINISH WALL ABOVE STANDOFFS

MAY USE COMBUSTIBLE FACING MATERIAL IN THIS AREA

NON-COMBUSTIBLE FINISH MATERIAL SEE FIG #11 & #12

STEEL FRAMING

STANDOFFS

NON-COMBUSTIBLE ZONE. DO NOT INSTALL ANY COMBUSTIBLE MATERIAL, ELECTRICAL WIRING OR GAS PLUMBING IN THIS AREA.

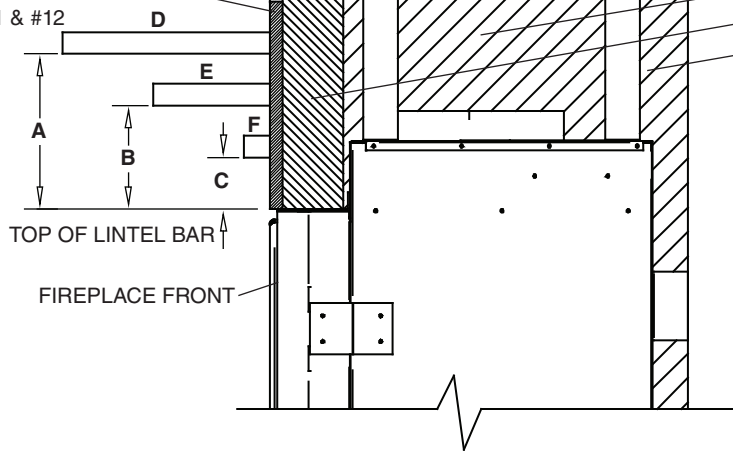

MANTEL CLEARANCE CHART

*** MANTEL CLEARANCE**

A	9"
B	6"
C	3"
** MANTEL DEPTH	
D	12"
E	6 3/4"
F	1 1/2"

Fig. #3

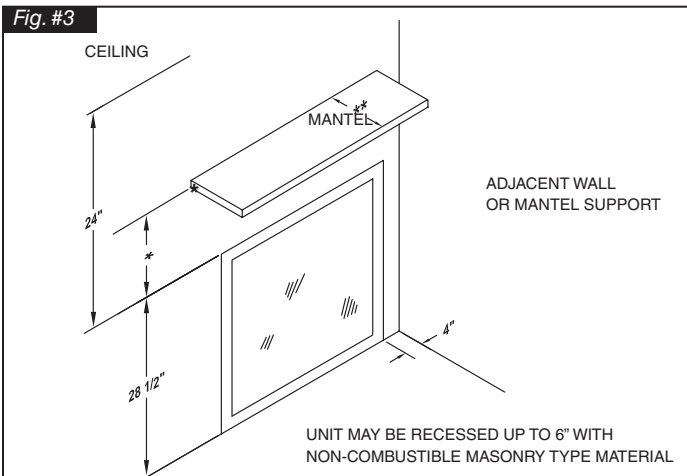

Minimum Clearances:

Side standoffs	0 in.	(0 mm)
Back standoffs	0 in.	(0 mm)
Top standoffs	0 in.	(0 mm)
Bottom of appliance	0 in.	(0 mm)
Adjacent side wall	4 in.	(102 mm)
Ceiling to appliance	24 in.	(610 mm)
*Mantel to appliance	See Figure #2	
**Maximum Mantel extension	See Figure #2	
Mantel support	4 in.	(102 mm)
Vertical vent pipe	1 3/4 in.	(45 mm)
Horizontal Vent pipe (Top, sides and bottom)	1 3/4 in.	(45 mm)

Fig. #4



Fig. #5



Fig. #6

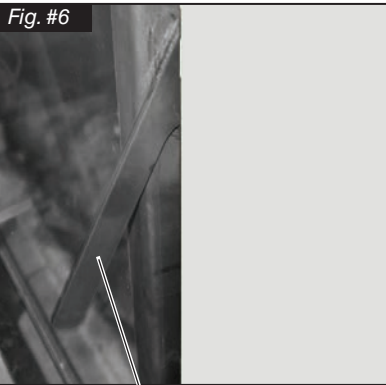

LATCH HANDLE

Fig. #7



Installation Requirements

The Town & Country Fireplace installation and venting must conform to the current CAN/CGA-B149 installation code (in Canada) or the current National Fuel Gas Code, ANSI Z223.1 (in the USA), and approved per local codes. Only qualified (licensed or trained) personnel should install this product.

In the state of Massachusetts, only a licensed Plumber and Gas Fitter may install this product.

Manufactured (Mobile) Home

In some jurisdictions, the Town & Country Fireplace may be installed in Manufactured Homes after the "first sale". **Consult local codes for approval.** The fireplace must be fastened in place.

Install in accordance with the current standard Mobile Homes, CAN/CSA Z240 MH (in CANADA), and the Manufacturer's Home Construction and Safety Standard, Title 24 CFR, Part 3280 or the current Standard for Fire Safety Criteria for Manufactured Home Installations, Sites and Communities ANSI/NFPA 501A (in the USA).

Window Frame Removal

Warning: Turn off the fireplace, and allow ample time for the unit to cool before proceeding.

Caution: The ceramic glass is very fragile, and should be handled with care.

The window frame is held in place by two spring-loaded latches that are operated by a one-piece latch handle.

1. Remove safety barrier screen (Fig #4) by prying the top portion of the screen toward you , then lift the screen from its tabs (inset) located at the base of the window frame.
2. Remove the TC Finishing Touch Trim Kit from the window frame. (If installed)
3. Using a screwdriver (Fig #5) or other similar object, push against the notch in the top of the latch and grab the bottom of the latch handle as it protrudes (Fig #6). Lift handle until latch hook disengages. Repeat for other side while holding glass so it does not tip out.
4. Tilt the top of the window frame out to clear the top edge of the unit. Grasp the sides of the frame and lift up and out to disengage from its bottom track.
5. Place the window frame in a safe place to avoid damage.
6. Re-assemble in reverse order. Latch handle should snap into place and be flush with window frame when engaged correctly.
7. Reinstall Trim Kit if required.
8. Reinstall safety barrier screen.

TIP:

To ensure glass is properly latched, grasp the top left and right sides of the glass frame, under moderate pressure it should pull forward and return to original position evenly on both sides.

Top Standoffs

The top standoffs are shipped loose inside the fireplace and must be installed on top of the fireplace as shown in Fig #8. Do this once the fireplace is on site and in position.

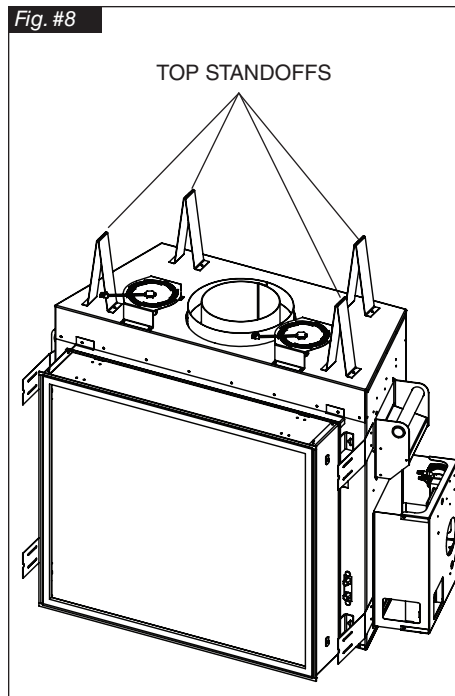

Locating The Fireplace

In planning the installation for the fireplace, it is necessary to determine where the unit is to be installed, location of vent system and where gas supply piping may be plumbed. Various installations are possible, such as, into an existing wall, a corner, a built-in wall or a wall projection (Fig #9). Due to high temperatures, do not locate this fireplace in areas of high traffic or near furniture or draperies.

The minimum clearances from the fireplace to combustible surfaces must be adhered to and are shown in Fig #2 and Fig #3.

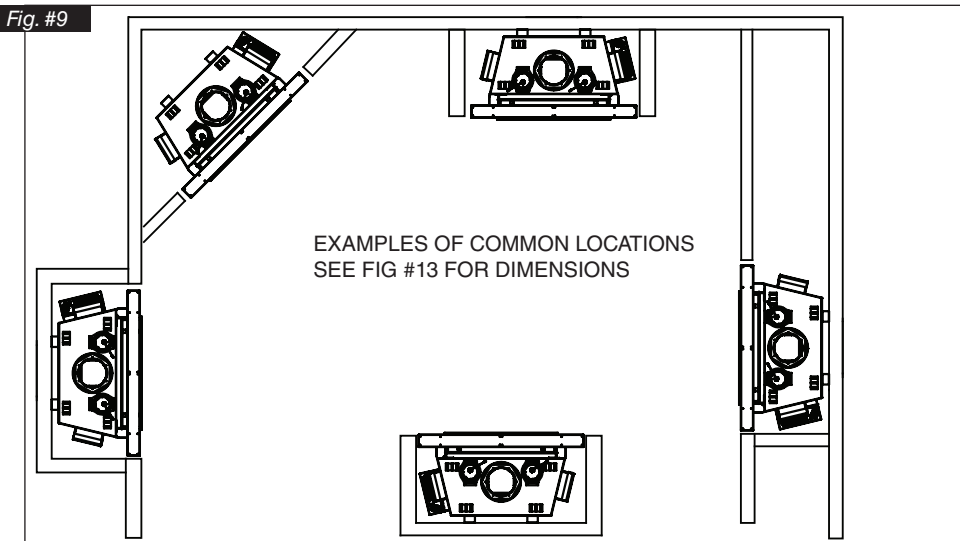

Framing and Finishing

Note: The fireplace should be in place and venting installed before framing in or building an enclosure around the unit.

The Town & Country fireplace must be framed in as described below or totally enclosed with non-combustible material, such as facing brick.

Determine the total thickness of facing material to be used. A thickness of 3/4" will allow the finishing surface to be flush with the front of the unit. If preferred, additional masonry type non-combustible material can be installed above and to the sides up to 6 inches proud of the appliance.

The finishing material must not interfere with glass frame access or movement.

A Steel Stud Framing Kit is supplied with the fireplace and must be used unless the fireplace is totally enclosed with non-combustible material. Assemble the framing kit as per the instructions on pages 10 & 11 of this manual. Attach the steel frame to the fireplace once the fireplace is in its final

position. Secure the steel frame to the framing brackets on each side of the unit. Ensure that the studs are set back far enough to allow for thickness of finishing surface.

The sides, back and top of the fireplace can be framed in up to the steel studs and the fireplace standoffs using conventional lumber. Consult local building codes for specific requirements.

Due to high temperatures, non-combustible backer board, such as cement board or it's equivalent must be used to sheet in the front of the fireplace, extending 12" above and 5 7/8" to the side of the framing edge bars. (Fig #11) Standard sheet rock (dry wall) may be used beyond this.

If the backer board is not to be finished with other non-combustible material such as tiles, it is recommended that the instructions in Fig.#11a be followed closely.

Chase Insulation: When installing this fireplace against a non-insulated exterior wall or chase, it is recommended that the outer walls be insulated to same degree as other exterior walls. Do not place fireplace directly against the insulation. Cover the insulation and plastic vapour barrier with a solid surface, such as dry wall (sheet rock). Consult local codes. Do not insulate or use plastic vapour barrier within the framing kit.

CAUTION: SEE FIGURE #11a BEFORE PROCEEDING.

NOTE:

The chase must be properly sealed at the ceiling level or between floors in a multilevel installation.

See "Ceiling Firestop" section.

Fig. #10

NON-COMBUSTIBLE ZONE. DO NOT INSTALL ANY COMBUSTIBLE MATERIAL, ELECTRICAL WIRING, INSULATION, PLASTIC VAPOR BARRIER OR GAS PLUMBING WITHIN THE STEEL STUD FRAMING

STEEL STUD FRAMING KIT DIMENSIONS (Supplied with fireplace)

ALL OTHER FRAMING CAN BE DONE WITH CONVENTIONAL LUMBER

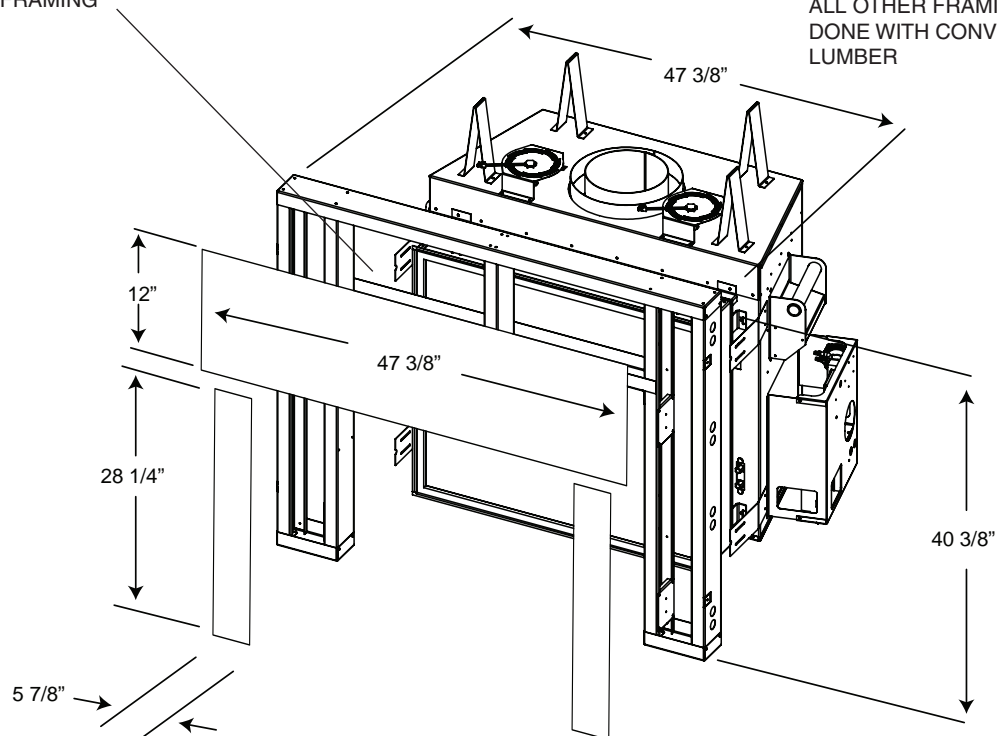
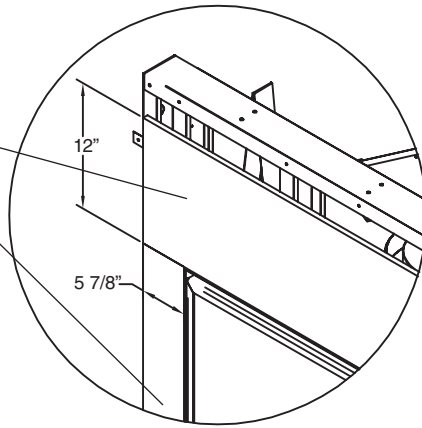

Fig. #11

NON-COMBUSTIBLE BOARD DETAIL

NON-COMBUSTIBLE
BOARD



NON-COMBUSTIBLE MATERIALS
MUST EXTEND 12" ABOVE AND
5 7/8" TO THE SIDES OF THE
FRAMING EDGES.

Fig. #11A

IF FINISHING THE WALL ABOVE THE UNIT
WITH PAINT, THE FRAMING KIT SHIPPED
WITH THE UNIT SHOULD BE DISCARDED.
USE FULL SHEETS OF CALCIUM SILICATE
BOARD OR EQUIVALENT AND FULL LENGTH
METAL STUDS TO FINISH AND FRAME
AROUND THE UNIT.

CALCIUM SILICATE BOARD IS A HIGH GRADE
MATERIAL WITH CEMENT, QUARTZ AND
NATURAL MINERALS AS THE MAIN RAW
MATERIALS. (NOTE: CALCIUM SILICATE IS
1/2" THICK)

CAUTION: CALCIUM SILICATE BOARD CAN
BE DAMAGED IF DROPPED OR STRUCK.
HANDLE WITH CARE. INSPECT BOARD
PRIOR TO INSTALLATION AND DO NOT USE
IF CRACKED.

NOTE: IT IS RECOMMENDED TO PRE-DRILL
MOUNTING HOLES IN THE BOARD PRIOR
TO SECURING TO THE FRAMING. THIS WILL
PREVENT THE BOARD FROM CRACKING.

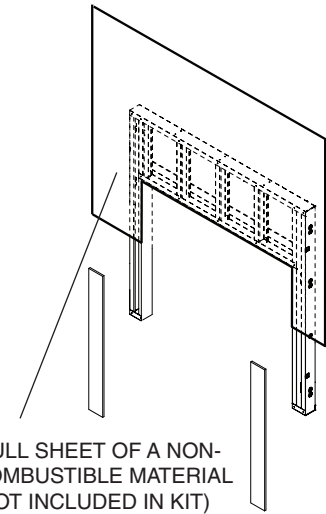

FULL SHEET OF A NON-
COMBUSTIBLE MATERIAL
(NOT INCLUDED IN KIT)

Fig. #12

NON-COMBUSTIBLE RECESSED INSTALLATION DETAIL

NON-COMBUSTIBLE
BOARD

STEEL STUDS

NON-COMBUSTIBLE
MASONRY TYPE MATERIAL

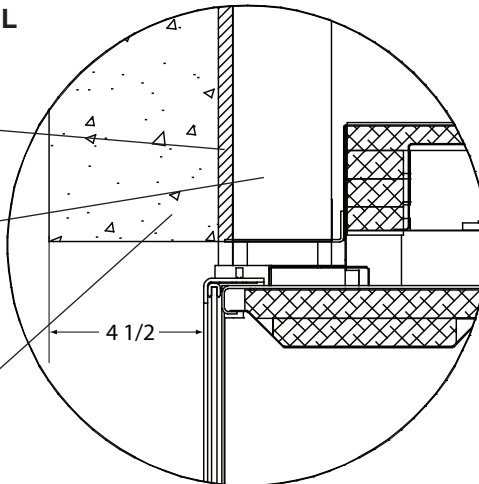
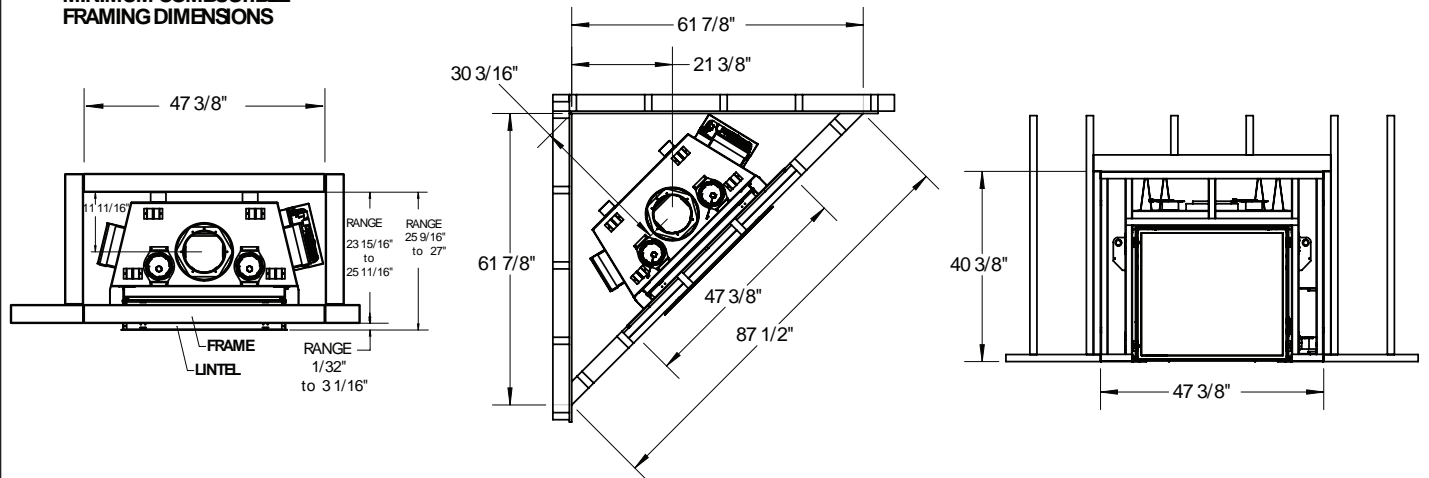

Fig. #13

MINIMUM COMBUSTIBLE FRAMING DIMENSIONS



NOTE: FIREPLACE SHOULD BE IN ITS FINAL LOCATION BEFORE FRAMING.

TC30 Steel Stud Framing Kit TC30.FRKIT

Each Kit Contains:

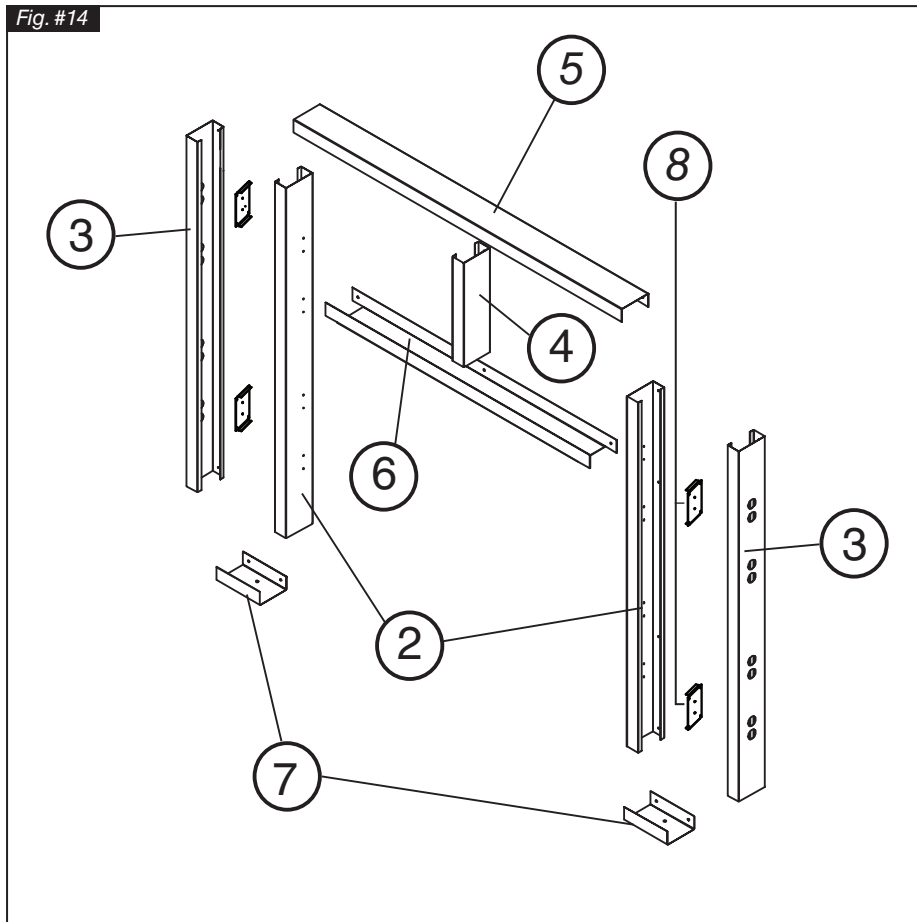

Item	Description	Qty
1	Screw, Teks #8 x 1/2" (Not Shown)	Pkg 40
2	Stud, Sides Inner, 40 1/4" L	2
3	Stud, Sides Outer, 40 1/4" L	2
4	Stud, Center, 12" L	1
5	Stud, Header Horizontal, 43 1/2" W	1
6	Stud, Plate Horizontal 35 1/16" W	1
7	Base Plate 5 3/4" L	2
8	Framing Plate	4

CAUTION

Edges are sharp, always wear gloves when working with sheet metal.

1. Top Frame Assembly

- Lay out side studs (2) and center stud (4) on a large flat surface. (Fig #14)
- Using the screws provided (1), attach the header stud (5) and the plate stud (6) to the center stud (4).

2. Attach Side Studs (Legs)

- Fasten the Inner side studs (2) to the header (5) and plate (6) studs.
- Attach the outer side studs (3) to the top of the header stud (5). (Fig #14)
- Fasten the outer side studs (3) at the bottom using the base plates (7).

3. Attach the Assembled Frame to the Unit

- Align and secure the framing plates (8) to the frame so that they are in line with the framing brackets on the fireplace unit (Fig #15). Align the assembled frame to the unit framing brackets. (Fig #15) Attach at the fastening points through the access holes in the outer side studs (3).

4. Secure to Existing Framing

- Secure the frame assembly to existing framing through the stud header (5) and the stud plates (7).

5. Install non-combustible Board Top and Sides

- Use drywall screws to install the non-combustible board top (8) and sides (9 - Fig #16)

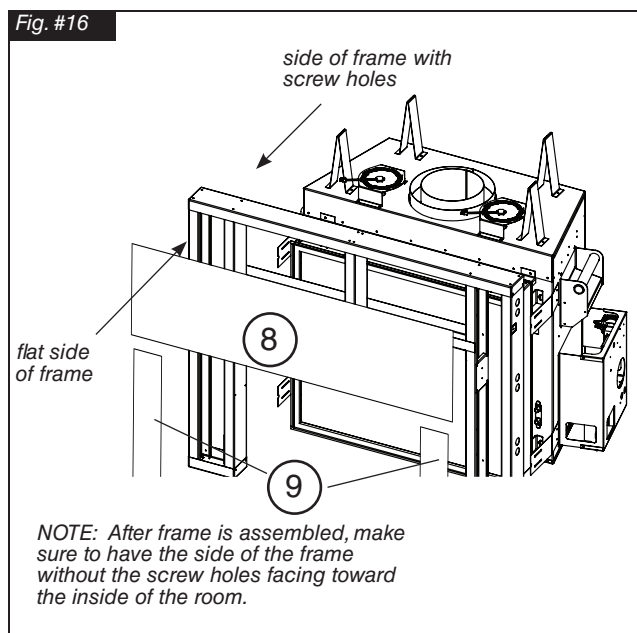
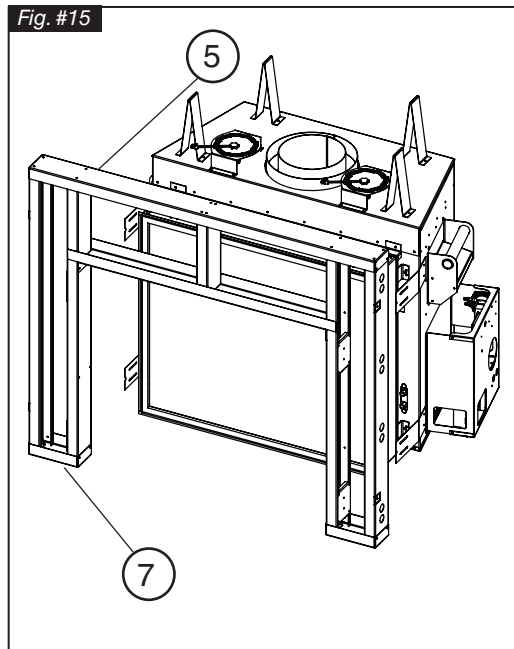

Adjustable Lintel

1. The adjustable lintel assembly has two orientations for desired finishing. A flanged edge and a hemmed edge. The lintel comes factory installed with the flange edge out. If the desired edge is different from the factory setting, use the following steps to change it.
2. Remove safety barrier screen.
3. Remove the window trim (Fig.#17).
4. Loosen the securing bolts in the upper and lower corners on each side of the lintel and remove the lintel. Rotate the assembly to have the desired edge away from the fireplace(Fig .#18).
5. The lintel assembly can then be adjusted to align flush with your facing material by sliding in or out approximately 1".
6. Tighten the securing bolts. (Fig.#18).
7. Re-attach the window trim.
8. Reinstall safety barrier screen

Fig. #17



SAFETY BARRIER
SCREEN

WINDOW TRIM

FLANGED EDGE

HEMMED EDGE

Fig. #18

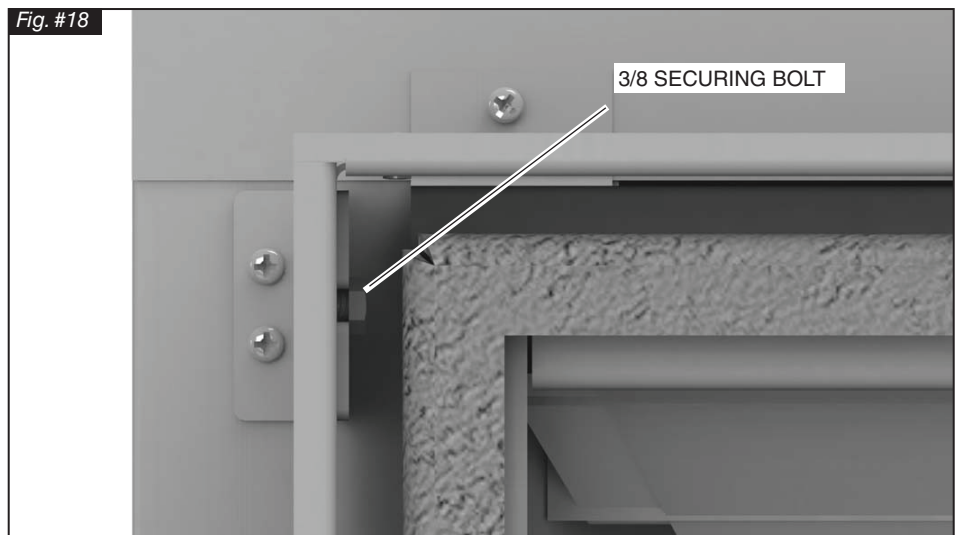

3/8 SECURING BOLT

This fireplace may be recessed up to a maximum depth of 6", this recess must be constructed from non-combustible material. The space between the outside framing edge and the firebox must be completely free of any obstructions or debris and the window, with trim fitted, must be able to move freely. No building material is permitted to protrude past the framing edges attached to the fireplace under ANY circumstance.

NON-COMBUSTIBLE
FINISH MATERIAL

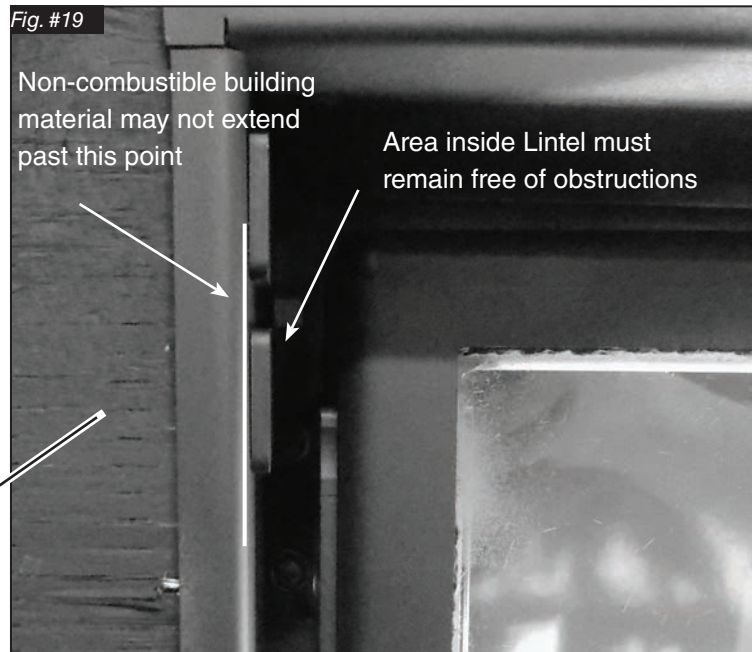

Hearth Extension

Fig. #20

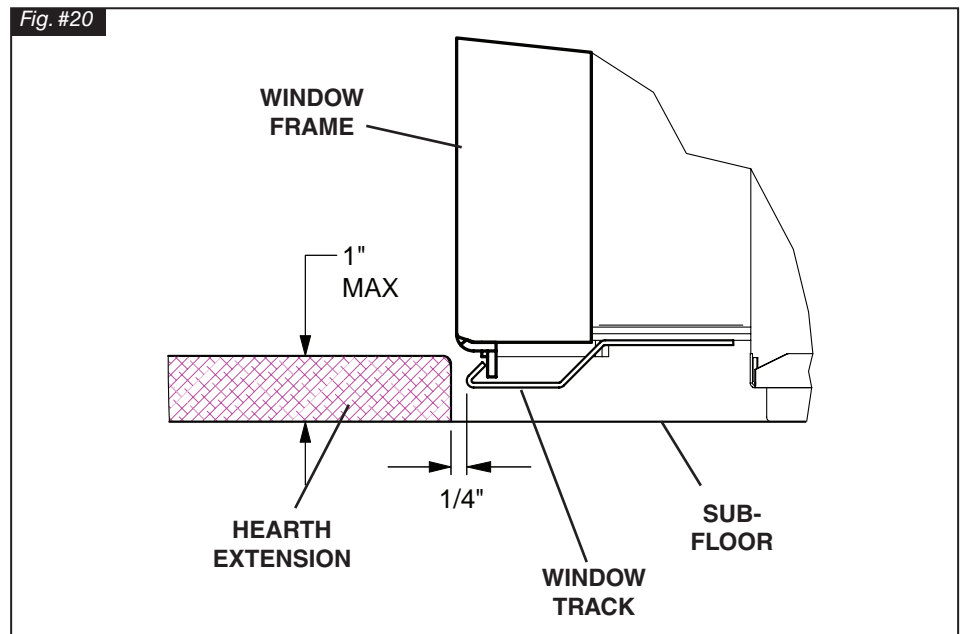

Caution: While a hearth extension is not required and combustible flooring materials may be brought directly up to the fireplace, many materials (such as wood flooring) may not tolerate the radiant heat from this fireplace, resulting in discoloration, shrinking and cracking. For this reason, we suggest a non-combustible hearth that is no more than 1" above the bottom of the fireplace. If thicker, fireplace must be raised accordingly.

Caution: Hearth extensions thicker than 1" will interfere with the window frame when opening.

Electrical

The gas control system is located on the right hand side of the firebox behind an access panel and the decorative firebox panel (if installed). The fireplace is operated via a wall control and a hand held remote control unit.

Note: Installation must be performed by a qualified installer, service agency or gas supplier.

The wall control is connected to the fireplace by a 40 ft. communication cable supplied with the fireplace.

Installation

1. Place the fireplace in the desired location.
2. Remove the window from the fireplace.
3. Remove access panel from right hand side of the firebox (Fig #21).
4. Connect 110 V. AC electrical supply to the wires installed inside the junction box (Fig #22). The fireplace is rated at 110 volts, 60Hz, 0.25A. The optional power vent kit is rated at 115 volts, 60Hz, 1.8A.

The electrical wires can be accessed from both inside and outside the junction box by removing one of the two small access panels (Figs #22 & 23).

5. Attach the wall switch to the framing in the desired location (Figs #24 & 25). (40 ft is supplied with fireplace).
6. Route the wall switch control cable (supplied) as required to the wall switch (Fig #25).
7. Attach one end of the wall switch control cable to the wall control. (Fig #25), and the other end to the interface board (Fig#23).
8. Insert the 4 supplied "AA" batteries into the battery pack of the wall switch. (Fig #26).
9. If not already installed, install the burner using the instructions supplied with the burner kit.
10. Turn on the gas supply and check that all connections are tight and leak free.
11. Turn on gas and electrical supplies.
12. Move the center button on the wall control (Fig #24) to the "ON" position. The igniter will start to spark. After a short delay, the pilot will light followed by the main burner.

FIREBOX ACCESS PANEL



JUNCTION BOX

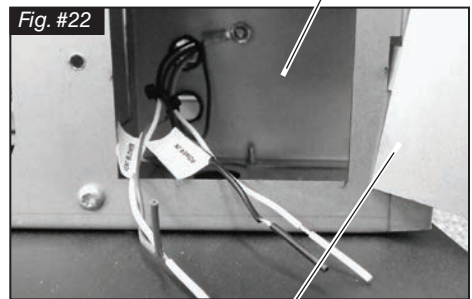

OUTER ACCESS PANEL

VACUUM SWITCH

TRANSFORMER

REGULATOR BOARD

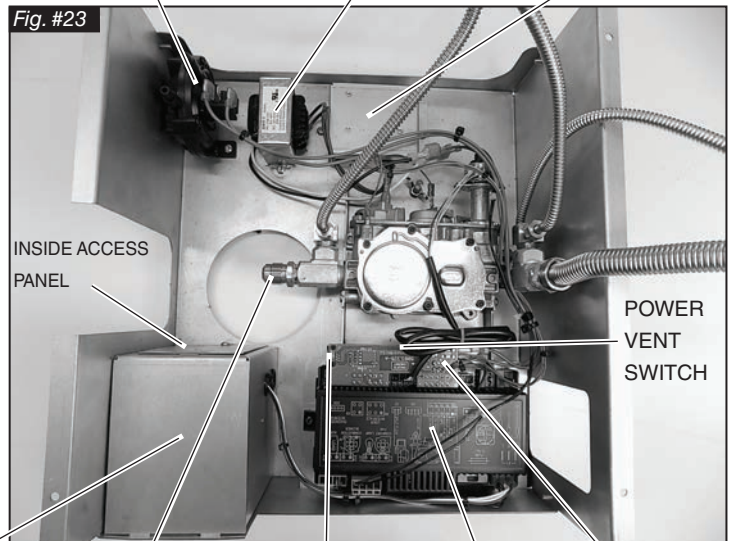

JUNCTION BOX

GAS CONNECTOR

WALL SWITCH CONNECTOR

IFC MODULE

INTERFACE BOARD

POWER VENT SWITCH

Wall Switch and Remote Control

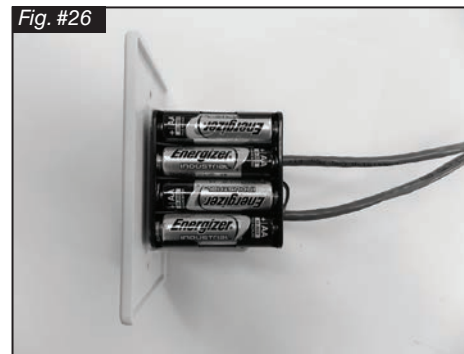
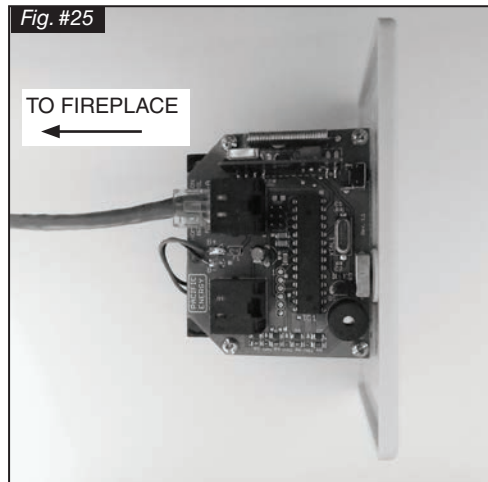

Linking the remote control unit to the wall switch.

1. Begin by moving the selector toggle on the wall switch to the "REMOTE" position.
2. Insert a straightened paper clip into the "PROGRAM" slot on the wall switch.
3. Press the internal "PROGRAM" button once and wait until you hear 3 beeps from the wall switch.
4. Press the ON/OFF button of the remote unit. Once the wall unit beeps 3 times, the remote is programmed.
5. The toggle on the wall switch must be kept in the "REMOTE" position in order to use the remote control unit.

Selecting Natural Vent and Power Vent Modes

The NV / PV (Natural Vent / Power Vent) switch (Fig #27) on the interface board (Fig #23) is set according to which type of evacuating vent system is present. If the fireplace is vented without the assistance of a power vent, the switch should be set to "NV". If using a power vent, "PV" should be selected. Follow the instructions provided with the power vent kit for proper installation.

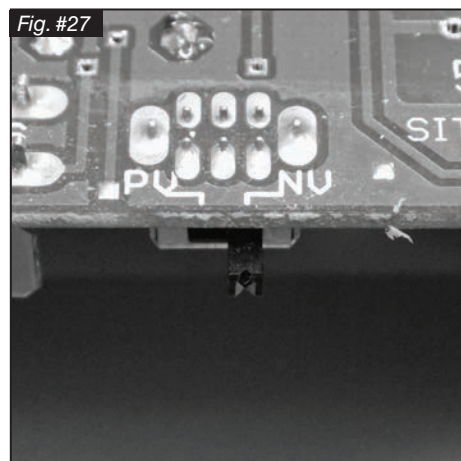

Home Automation

Fig. #28

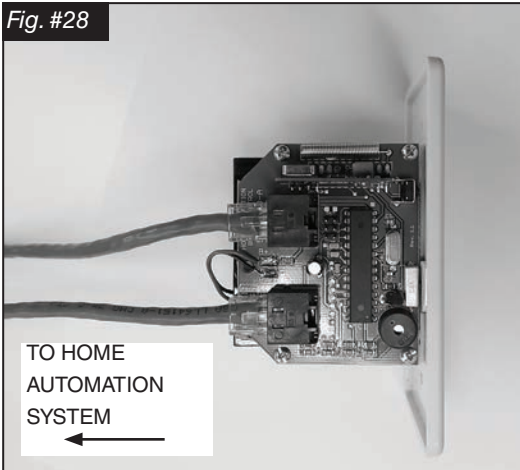

The home automation feature supplied with this fireplace is capable of controlling the flame and light on/off function with the use of a dry contact relay common to home automation systems. Furthermore, the flame and light level may be modulated from high to low using the 0 - 10 volt analog output available on most home automation systems.

Fig #29 shows the wire designations required to connect the fireplace to a home automation system.

NOTE:

When a signal has been supplied by the home automation system, the fireplace control will repeat the signal every 2 hours or until a new command has been received.

Fig. #29

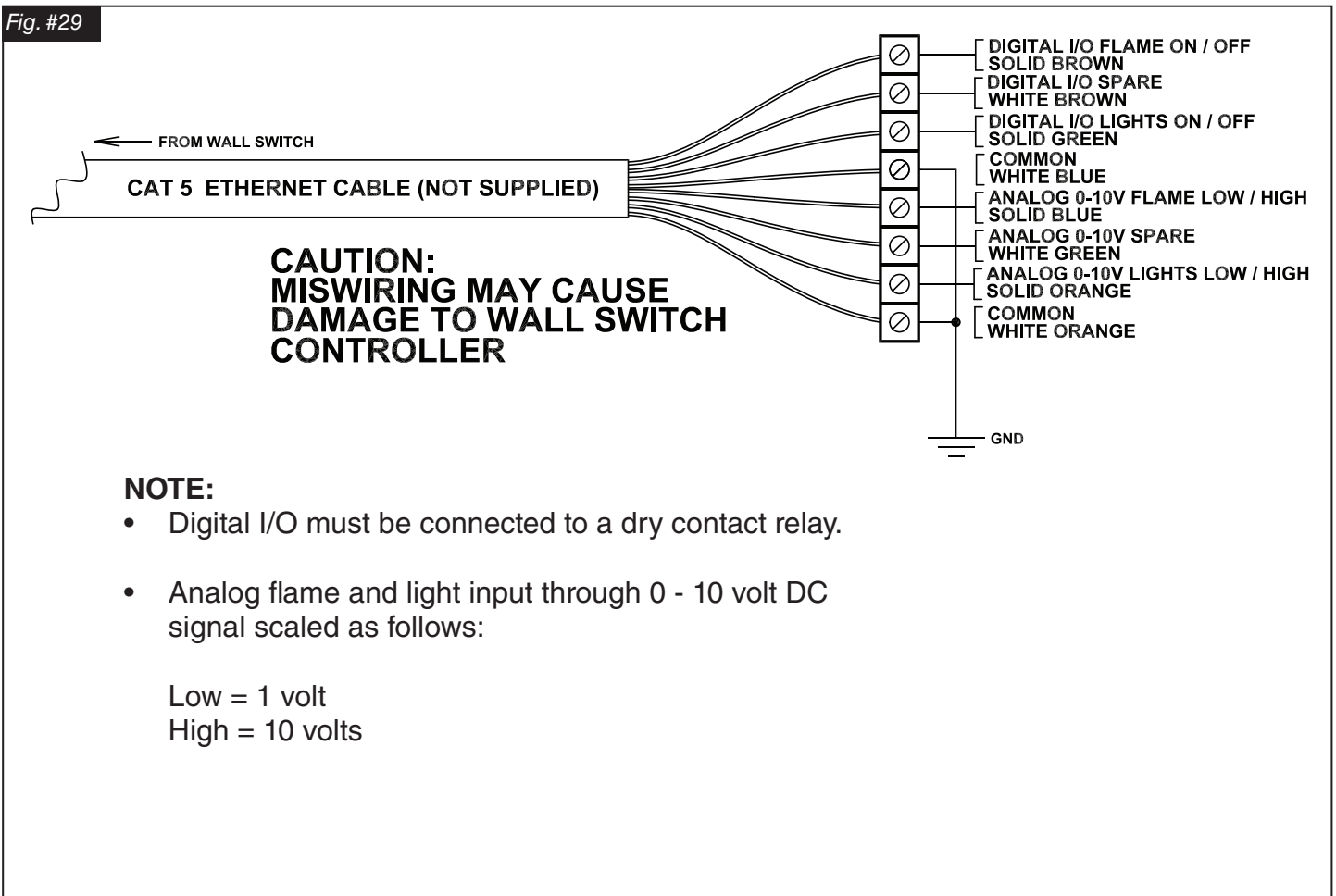

NOTE:

- Digital I/O must be connected to a dry contact relay.
- Analog flame and light input through 0 - 10 volt DC signal scaled as follows:

Low = 1 volt
High = 10 volts

Gas Supply

Caution: The gas line should be installed by a qualified service person in accordance with all building codes. This section is intended as a guide for qualified technicians installing this appliance. Consult local and / or national building codes before proceeding.

- Gas supply line access holes are located at the top and left sides of the Control Box. Gas valve inlet accepts a 3/8" N.P.T. fitting. Correct gas line diameter must be used to assure proper operation and pressure.
- **NOTE: A sediment trap, as per national fuel gas code, must be installed in the gas supply line no more than 6 feet from the gas control valve to minimize the possibility of any loose scale or dirt within the gas supply line from entering the control valve.**
- **DO NOT HARD PIPE GAS LINE TO VALVE.** A method of disconnecting the valve from the gas line such as a union or flare fitting must be provided to allow for repair or replacement of the gas valve.

Check local codes for additional requirements.

1. Connect the gas supply to the valve (Fig. #24)
2. Turn on the gas supply and check that all connections are tight and leak free.

WARNING: The access panel including gasket must be reinstalled after conversion/installation or servicing has been completed. Failure to do so will cause overheating and premature failure of the control system.

Gas Pressure Check

Note: To test the gas pressure, turn off the gas supply before removing the plug from the supply pressure test port or manifold pressure test port.

Verify gas pressures with the fireplace lit and on the highest setting.

Please refer to the Burner Installation Manual for gas pressure testing procedure.

Correct gas pressure requirement:

	Natural Gas	Propane
Min. Pressure (For purpose of input adjustment)	5.0" WC	12.5" WC
Max. Pressure	13.9" WC	13.9" WC
Manifold Pressure		
Maximum	3.5" WC	10" WC
Minimum	1.6" WC	6.4" WC

Fig. #30

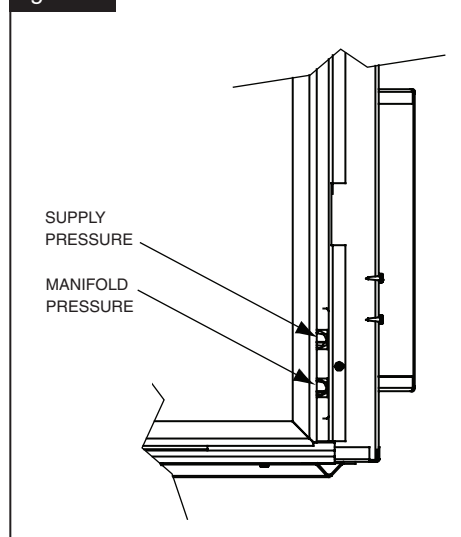

Venting

Before installing venting for this unit, the installer should read these instructions to insure that the proper vent configuration has been selected.

Use only Town and Country Termination kits #:

- TCVT.WTA - Wall Termination Kit
- TCVT.RTA - Roof Termination Kit

Vent system components approved for use with the Town and Country Fireplace are shown in Fig. #33.

NOTE: Optional PowerVent (TCVT.PVI.25,TCVT.PV7.110 &TCVT.PVCV) requires different venting. Please refer to Power Vent manual.

Various combinations of vertical and horizontal runs may be used. Refer to Fig. #35 and 36 for details. For optimum performance and flame appearance, keep the vent length to a minimum and limit the number of elbows. Connections between each vent system component must be tightly joined, secured with sheet metal screws and sealed with provided high temperature self adhesive tape. A horizontal run of vent should have a 1/4" rise for every 1 ft. of run towards the termination.

VENT SUPPORTS: A minimum of 1 support every 4' must be used.

CAUTION: UNDER NO CONDITION SHOULD COMBUSTIBLE MATERIAL BE CLOSER THAN 1 3/4 INCHES FROM THE TOP AND 1 3/4 INCHES FROM THE SIDES OF A HORIZONTAL SECTION AND 1 3/4 INCHES FROM THE VERTICAL SECTIONS OF THE VENT PIPE.

Wall Termination Venting

Exterior wall opening:

Determine the exact position of the fireplace so that the vent pipe is centred (if possible) between two building framing members. Consult your local building codes prior to proceeding. The vent kit will accommodate up to a maximum wall thickness of 12 inches.

1. Having determined the position of the fireplace, cut and frame a 14 1/2 inch opening centred at a minimum height of 52 7/16 inches above the floor. The opening may be round or square. Height of the opening will vary with each installation. As the horizontal vent run increases, so does the minimum vertical rise (see Fig. #35).

IMPORTANT: When locating the opening, it should be noted that vent terminal clearances must be maintained. See "Vent Terminal Clearances" section for proper clearances.

A minimum 1 foot length of pipe is required before the first elbow off the top of the fireplace for any wall termination. With this minimum vertical rise in combination with a 90° elbow, a maximum horizontal run of 24 inches past the elbow is permitted (see Fig. #34 & #35). For longer horizontal runs increase vertical rise appropriately.

The rise and run must be constrained to the boundaries of the chart shown in Fig. #35. The horizontal run of vent must have a 1/4" rise for every 1 ft. of run towards the termination.

Fig. #31

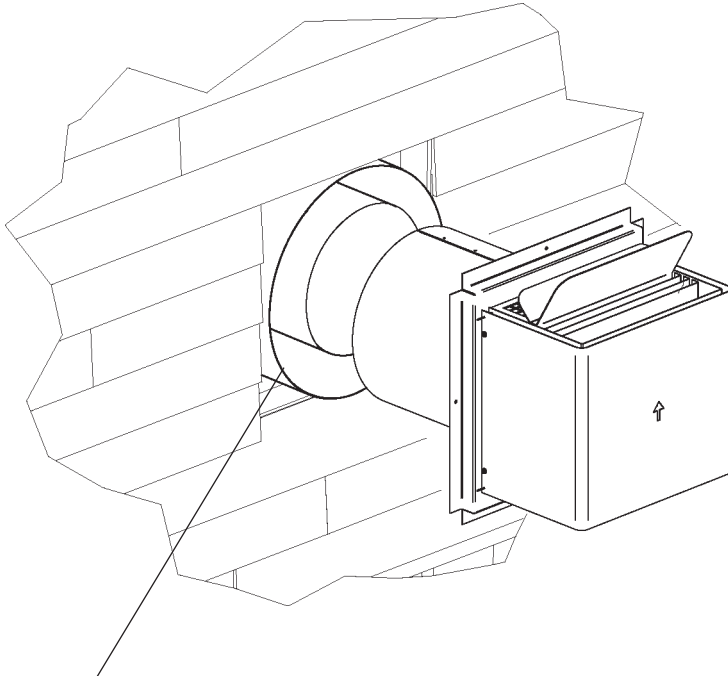

WALL THIMBLE AND VENT MUST NOT PROTRUDE BEYOND SIDING

Wall thimble:

Where a vent pipe passes through a combustible wall, a wall thimble/shield must be used to retain insulation and maintain proper clearances. The wall thimble may be cut to length for various wall thicknesses up to 12" thick.

Measure the wall thickness including the siding. Trim the shield to match the wall thickness. Position the wall thimble from inside through the 14-1/2" opening. Properly adjusted, the thimble should be flush with the outer wall surface.

Fig. #32

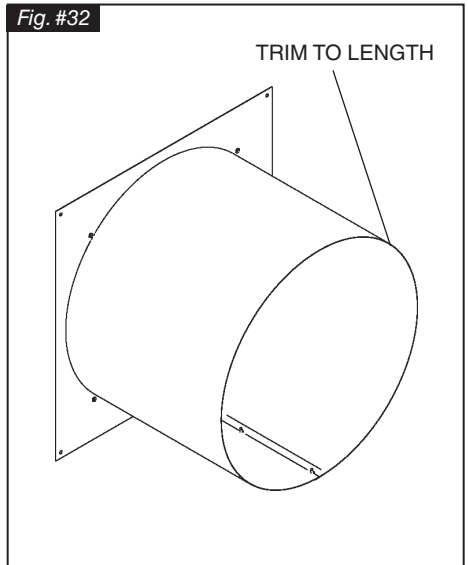

Fig. #33

Vent System Components

Town & Country

12" Pipe Length	TCVT.811X12
18" Pipe Length	TCVT.811X18
24" Pipe Length	TCVT.811X24
48" Pipe Length	TCVT.811X48
12" Adjustable Pipe Length.....	TCVT.811X12ADJ
45° Elbow	TCVT.811XLB45
90° Elbow	TCVT.811XLB90
Wall/Offset Support	TCVT.811XOS
A minimum of 1 support every 4' must be used.	
Wall Termination Kit.....	TCVT.WTA
Roof Termination Kit	TCVT.RTA
Wall Shield/Ceiling Firestop	TCVT.THIMA
Roof Flashing, Adjustable	TCVT.811FLADJ
Roof Flashing, Flat	TCVT.811FLFLT
Roof Flashing, Steep	TCVT.811FLSTP
	or any flashing that fits 11" pipe

Vent pipe:

Install vent pipe through the wall thimble and attach to flue outlet collar on top of the fireplace. Secure all joints with screws and seal with approved "High Temp." self-adhesive aluminum tape provided.

Adjust the fireplace position so that the vent pipe does not protrude beyond the outer wall. The vent connector on the termination will accommodate walls up to 12" thick.

Wall vent terminal:

- 1) Engage the terminal with the vent pipe and slide terminal into place. Ensure that both inner and outer pipes are fully engaged and then attach the terminal to the outside wall. **The vent terminal must not be recessed into the exterior wall or siding.**
- 2) Caulk in place to prevent any moisture entering the building.

NOTE: MINIMUM CLEARANCES TO THE VENT TERMINAL MUST BE MAINTAINED (see Fig. #40 & 41).

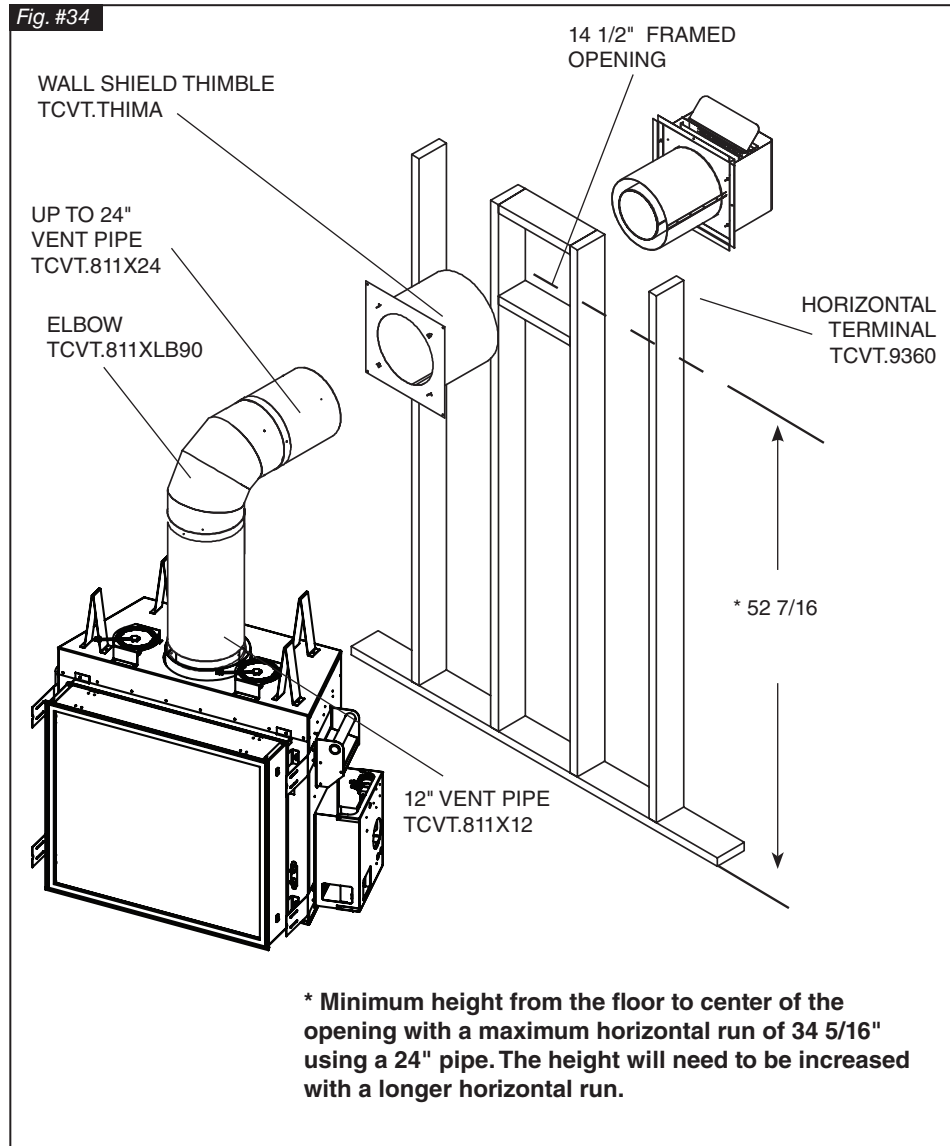

Wall Termination Venting Chart

Fig. #35

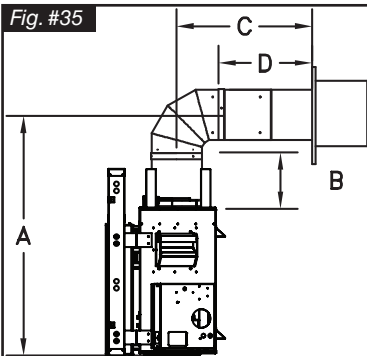

**

A Minimum rise	B Pipe length	C Maximum run	D Pipe length Max.
52 7/16"	1 x 12"	34 5/16"	1 x 24"
64 7/16"	1 x 24"	46 5/16"	1 x 24" + 1 x 12"
74 11/16"	1 x 24" + 1 x 12"	166 5/16"	3 x 48" + 1 x 12"
80 11/16"	1 x 24" + 1 x 18"	226 5/16"	4 x 48" + 1 x 24"
87 11/16"	1 x 48"	250 5/16"	5 x 48"

For other rise/run combinations see chart below

** All dimensions are approximate. Both rise and run may vary with different combinations of pipe.

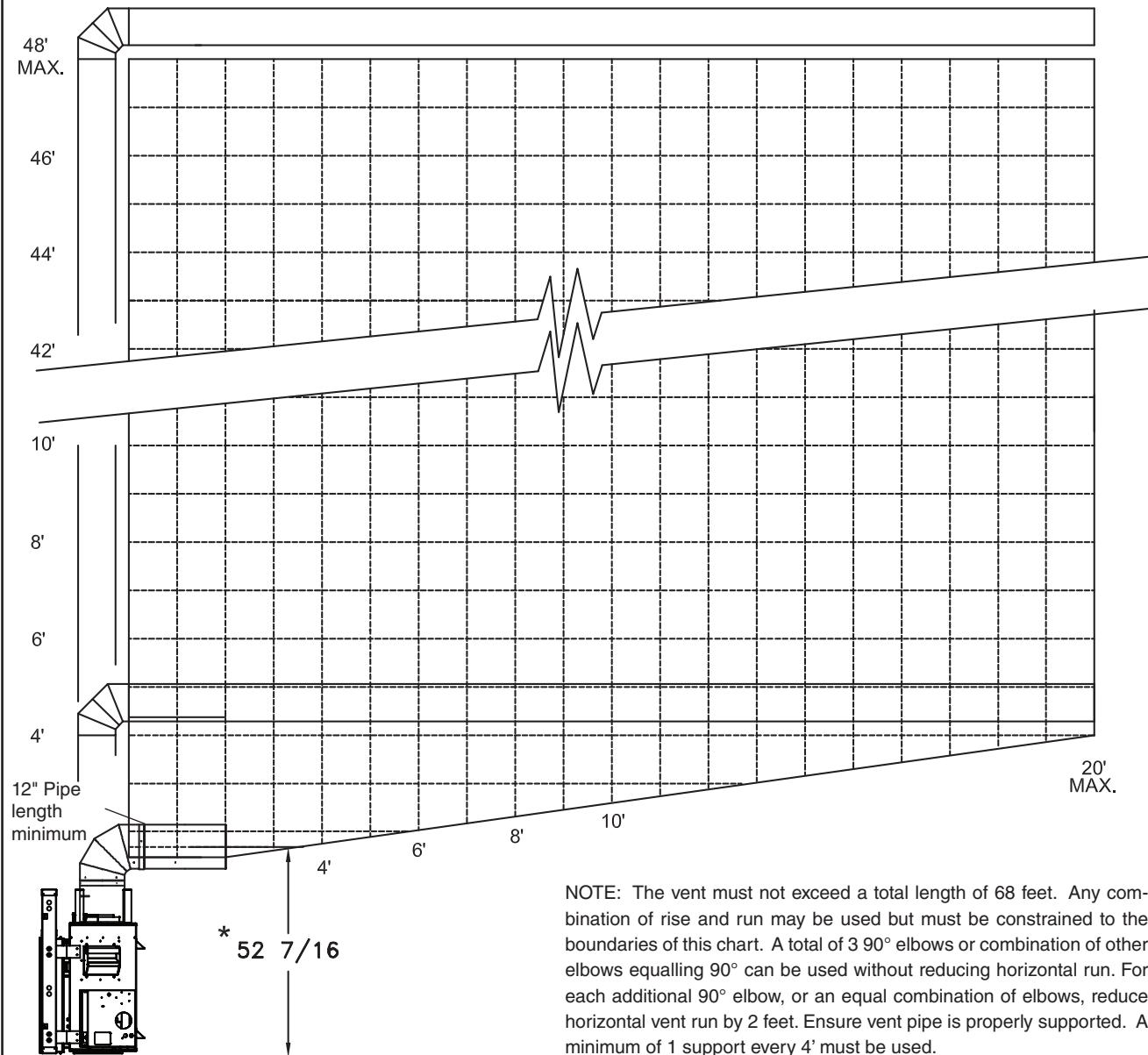

NOTE: The vent must not exceed a total length of 68 feet. Any combination of rise and run may be used but must be constrained to the boundaries of this chart. A total of 3 90° elbows or combination of other elbows equalling 90° can be used without reducing horizontal run. For each additional 90° elbow, or an equal combination of elbows, reduce horizontal vent run by 2 feet. Ensure vent pipe is properly supported. A minimum of 1 support every 4' must be used.

Roof Termination Venting Chart

Fig. #36

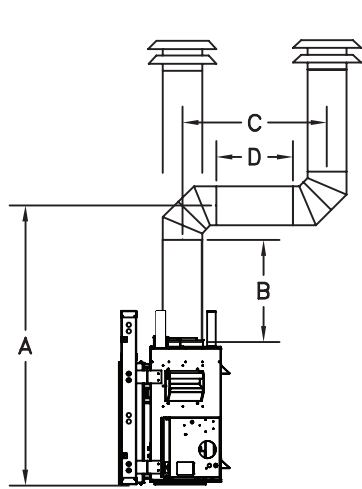

**

A Minimum rise	B Pipe length	C Maximum run	D Pipe length Maximum
52 7/16"	1 x 12"	41"	1 x 24"
64 7/16"	1 x 24"	51 1/4"	1 x 24" + 1 x 12"
74 11/16"	1 x 24" + 1 x 12"	167 3/4"	3 x 48" + 1 x 12"
80 11/16"	1 x 24" + 1 x 18"	226"	4 x 48" + 1 x 24"
87 11/16"	1 x 48"	250"	5 x 48"

For other rise/run combinations see chart below

** All dimensions are approximate. Both rise and run may vary with different combinations of pipe.

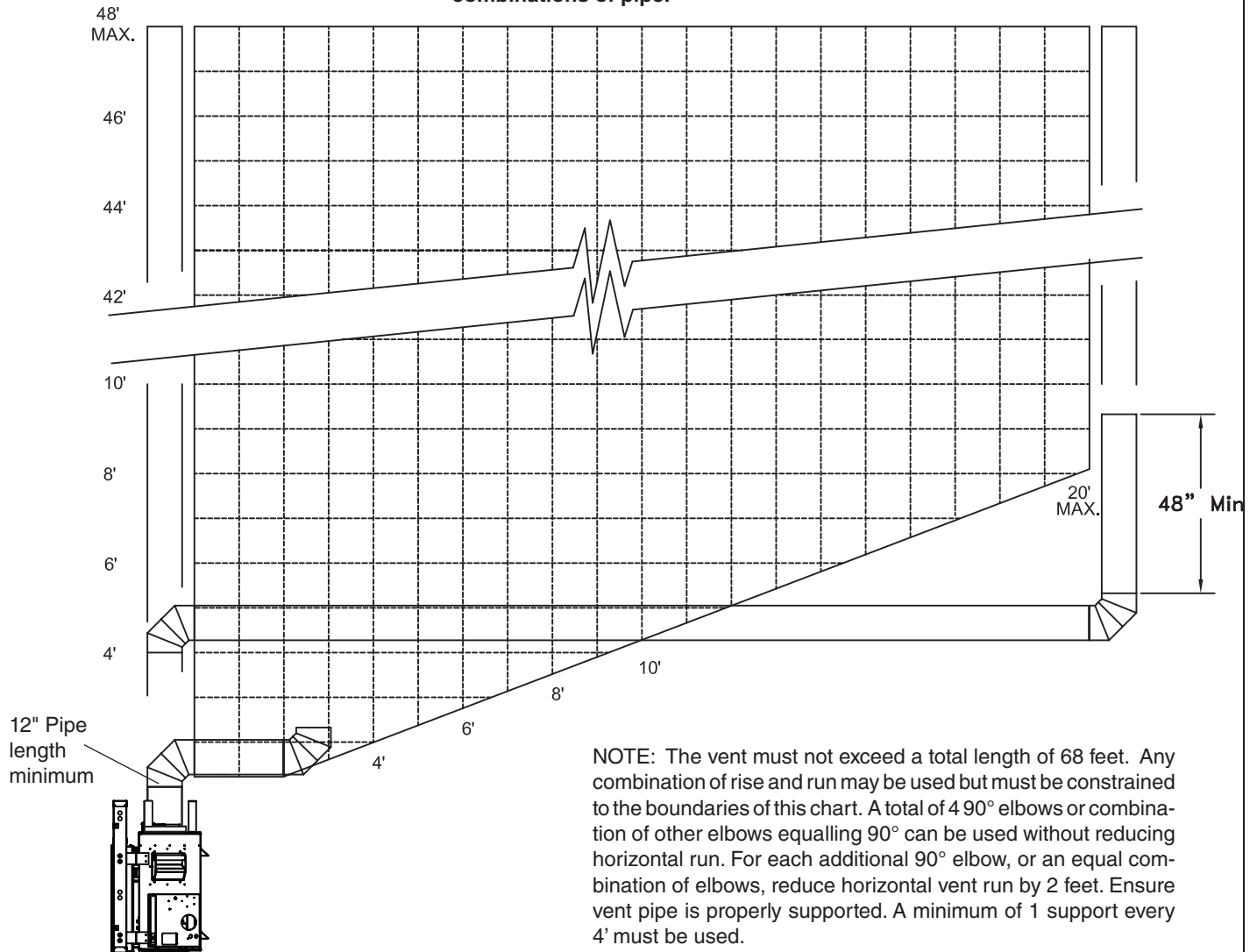

NOTE: The vent must not exceed a total length of 68 feet. Any combination of rise and run may be used but must be constrained to the boundaries of this chart. A total of 4 90° elbows or combination of other elbows equalling 90° can be used without reducing horizontal run. For each additional 90° elbow, or an equal combination of elbows, reduce horizontal vent run by 2 feet. Ensure vent pipe is properly supported. A minimum of 1 support every 4' must be used.

Roof Termination Venting

Ceiling Opening:

1. Determine the exact position of the fireplace so that the vent pipe is centred (if possible) between two building framing members. Lay out the vent system path, minimizing the number of elbows and length of vent. Consult your local building codes prior to proceeding.
2. Cut and frame a 14 1/2" opening in the floor, ceiling or roof where the vent system will pass. Size of the opening in the roof may need to be increased as the pitch of the roof increases. Avoid cutting rafters.

Ceiling Firestop:

Where a vent pipe passes through a floor or ceiling, a ceiling firestop must be used to retain insulation and maintain proper clearances.

From below, push the ceiling firestop through the opening and secure in place. If the firestop is used to penetrate a floor, the outer shield may be trimmed in length. If the firestop penetrates into an attic, leave the shield full length to keep insulation away from the vent pipe. Additionally, after the vent pipe is in place, install a storm collar on top of the shield. This will prevent loose insulation from falling into the area between the vent pipe and the shield.

Fig. #37

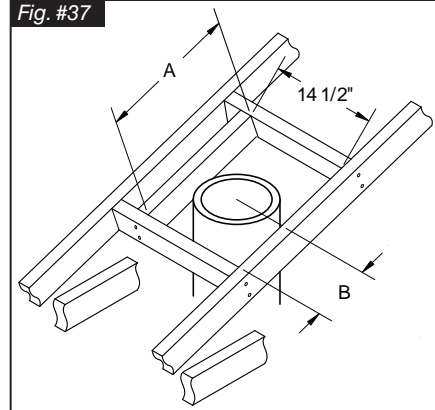

Size of the opening will have to increase with the pitch of the roof to ensure a 1 3/4" inch air space clearance between vent pipe and combustibles.

Roof Pitch	A	B
0/12	14 1/2"	7 1/4"
4/12	16 1/2"	8 3/4"
6/12	18"	10"
8/12	19 3/4"	11"
12/12	24"	13 3/4"

Fig. #38

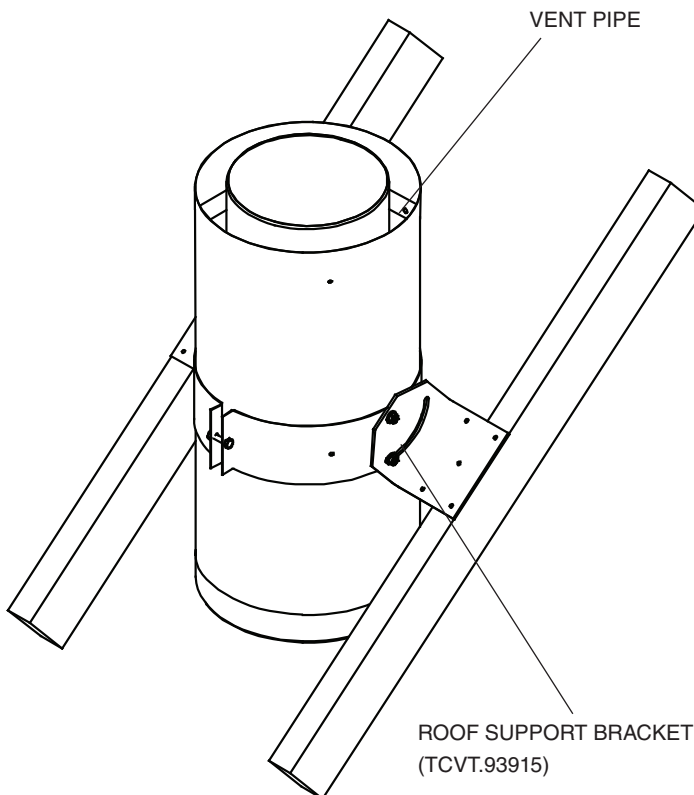

Vent Pipe:

1. Install the first section of vent pipe into the collar on top of the fireplace. Secure in place with screws and seal with approved "High Temperature" self-adhesive aluminium tape provided.
2. Continue adding vent pipe lengths up and through the firestop(s) and through the roof. The vent pipe must extend at least 12" above the roof. Vent pipe may need to extend further depending on the roof pitch. See chart on Fig #40a for precise lengths.

Seal the vent pipe as per "Vent Pipe Sealant" section (Fig #42).

Roof Support Bracket:

Slip the roof support bracket down over the vent pipe. Rotate the 90° brackets to accommodate roof pitch. Attach the brackets to the roof joists with nails or building screws. Tighten the band around the vent pipe and secure in place with screws.

Roof Vent Terminal:

1. Place the roof flashing over the vent pipe, secure and seal it to the roof using the methods and materials appropriate for the type of roof on the building. Shingle roof example shown (Fig #39).
2. Place the storm collar down over the vent pipe until it is level. Tighten storm collar for a snug fit. Apply a thick horizontal ring of mastic around the pipe at top of the storm collar. (Fig #39)
3. Lower the roof vent terminal cap over the vent pipe and secure in place with screws provided. (Fig #39) Seal screw heads and joints with caulking to prevent any moisture entering the venting system.

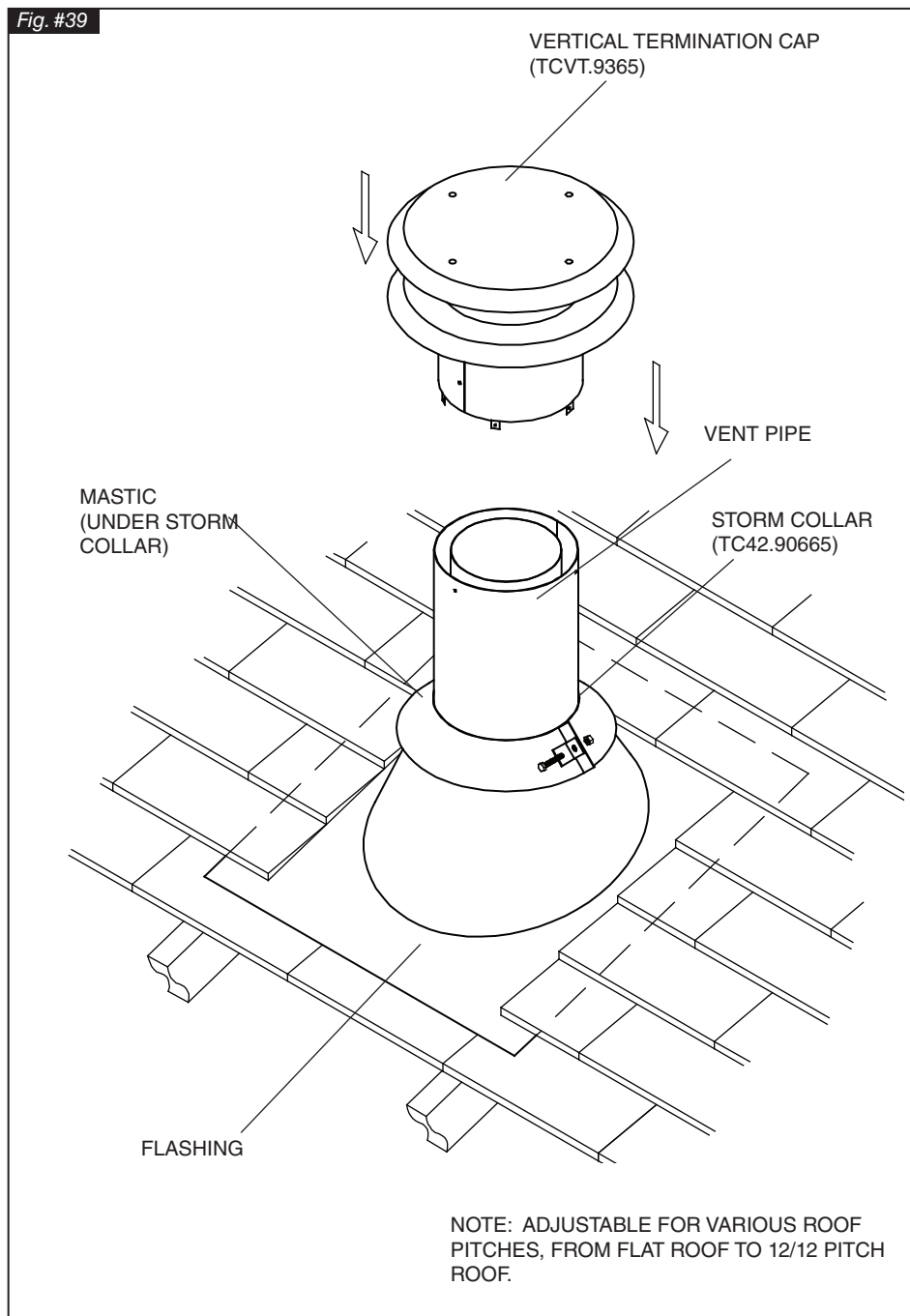

Vent Terminal Clearance

Minimum clearances to the vent terminal must be maintained as shown in figure #40 & 41. Measure clearances to the nearest edge of termination hood.

NOTE: Vent terminal must not be recessed

NOTE: LOCAL CODES OR REGULATIONS MAY REQUIRE DIFFERENT CLEARANCES.

Fig. #40a

Terminal to sloped Roof Pitch Table (minimum)

	ft	m
Flat to 6/12	1.00	0.30
Over 6/12 to 7/12	1.25	0.38
Over 7/12 to 8/12	1.50	0.46
Over 8/12 to 9/12	2.00	0.61
Over 9/12 to 10/12	2.50	0.76
Over 10/12 to 11/12	3.25	0.99
Over 11/12 to 12/12	4.00	1.22

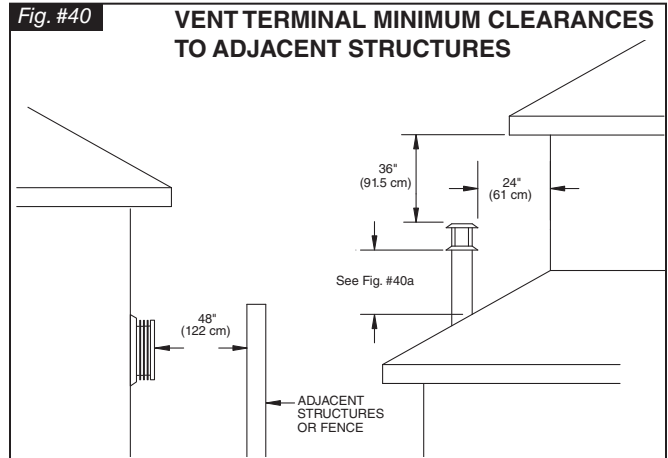

Vent Terminal Minimum Clearances

Fig. #41

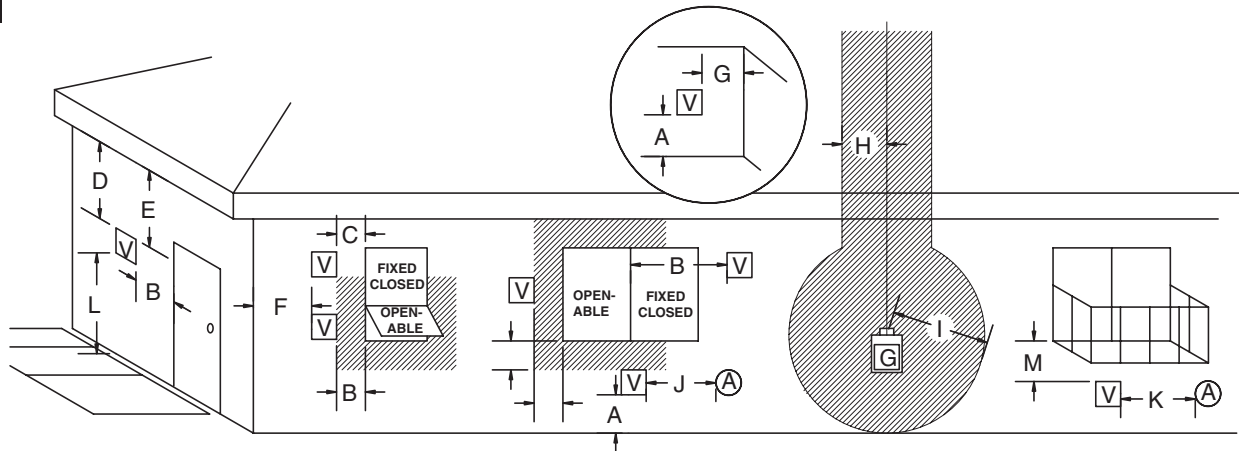

☐ VENT TERMINAL

Ⓐ AIR SUPPLY INLET

▨ AREA WHERE TERMINAL IS NOT PERMITTED

Ⓒ GAS METER

A=	*12 inches (30 cm) min.	Clearances above grade, veranda, porch, deck, or balcony
B=	*12 inches (30 cm) min.	Clearance to window or door that may be opened
C=	12 inches (30 cm) min.	Clearance to permanently closed window recommended to prevent condensation on window
D=	30 inches (76 cm) min.	Vertical clearance to ventilated soffit located above the terminal within a horizontal distance of 2 feet (60 cm) from the edge of the terminal
E=	30 inches (76 cm) min.	Clearance to unventilated soffit
F=	6 inches (15 cm) min.	Clearance to outside corner
G=	6 inches (15 cm) min.	Clearance to inside corner
H=	3 feet (90 cm) min.	*Not to be installed above a meter/regulator assembly within 3 feet (90 cm) horizontally from the center-line of the regulator
I=	*6 feet (1.8 m) min.	Clearance to service regulator vent outlet
J=	*12 inches (30 cm) min.	Clearance to non mechanical air supply inlet to building or the combustion air inlet to any other appliance
K=	*6 feet (1.8 m) min.	Clearance to a mechanical air supply inlet
L=	*7 feet (2.1 m) min.	^ Clearance above paved side-walk or a paved driveway located on public property
M=	**30 inches (76 cm) min	Clearance under veranda, porch, deck, or balcony

^ a vent shall not terminate directly above a side-walk or paved driveway which is located between two single family dwellings and serves both dwellings*

** only permitted if veranda, porch, deck, or balcony is fully open on a minimum of 2 sides beneath the floor*

* as specified in CAN/CSA B149.1 Installation Codes, Note: local Codes or Regulation may require different clearances

* for U.S.A. Installations follow the current National Fuel Gas Code, NFPA54/ANSI Z223.1

Vent Pipe Sealant

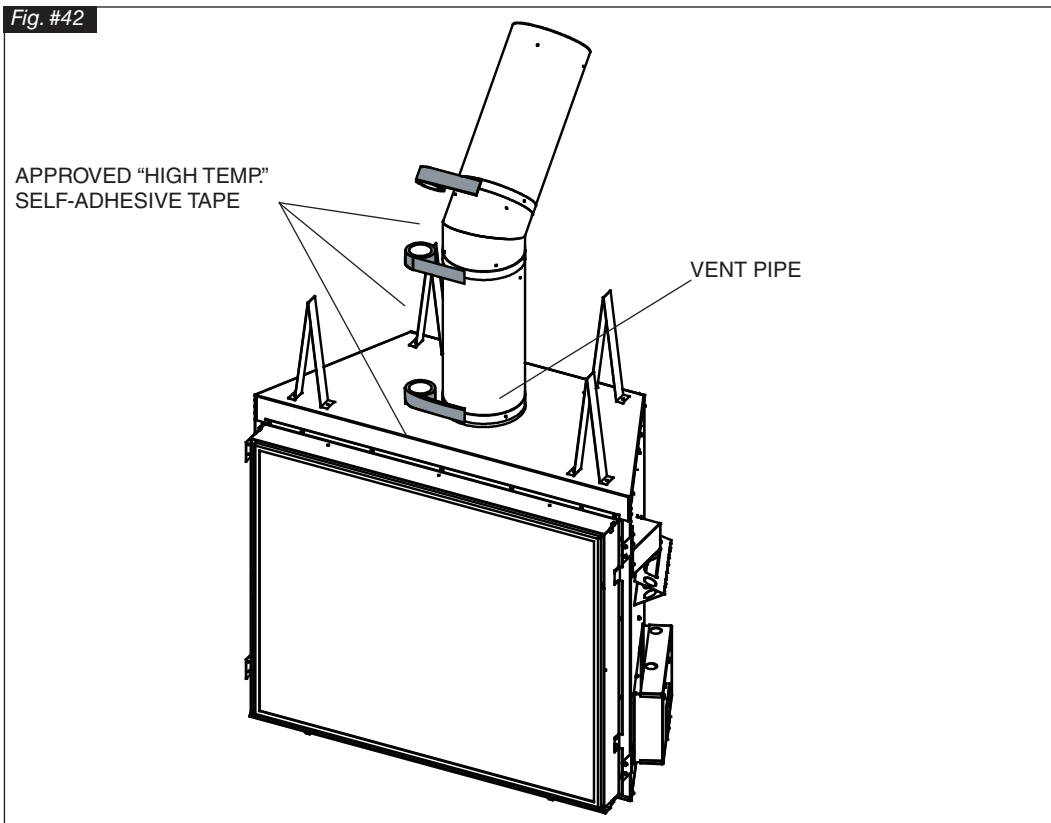

All outer joints of the vent pipe must be sealed with the approved "High Temperature" self-adhesive aluminium tape provided. Wrap the tape completely around the joint and press firmly in place.

Vent Restrictor Adjustment

The vent restrictor is located on the underside of the firebox top. The unit leaves the factory with the vent restrictor wide open. The restrictor is built into the appliance for secondary air flow adjustment. Adjustment enables tuning the airflow for optimum flame appearance and performance for a wide variety of vent configurations.

Setting:

- determine the vent height.
- determine the vent horizontal length.
- from the chart determine the restrictor position.

Refer to the chart in Fig. #43 for the correct position of restrictor for the vent configuration of your installation. Restrictor positions are based upon lab tests. The ideal position may vary slightly with installation.

Restrictor position is too closed if the flame has the following characteristics:

- Flame is excessively tall and lifting.
- Flame lacks movement.
- Flame soots.

Restrictor position is too open if the flame has the following characteristics:

- Flame height is low.
- Flame has excessive movement.

To adjust the restrictor:

- Loosen the screw holding the restrictor.
- Move the restrictor to its intended opening.
- Re-tighten the screw.

CAUTION: The vent restrictor must be fully open when using the power vent

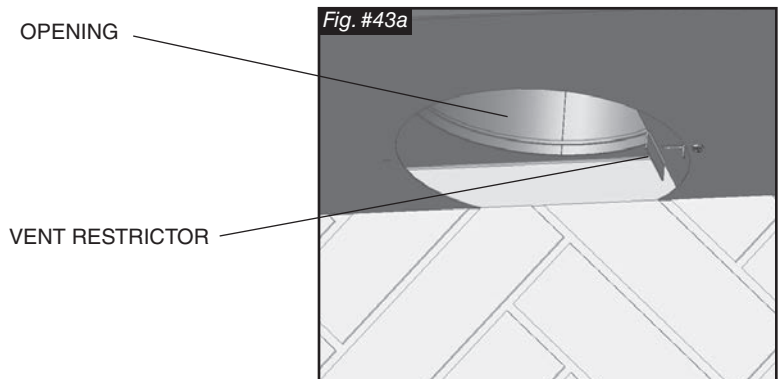
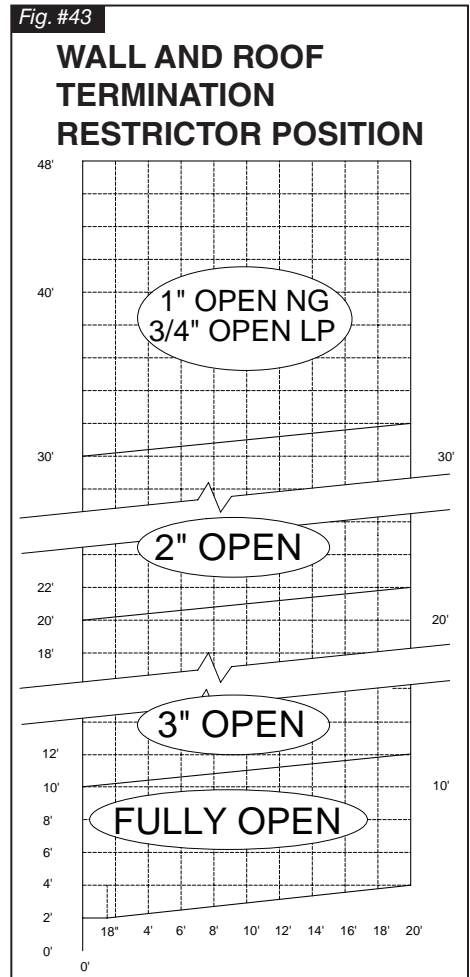

Wall Shield/ Ceiling Firestop Thimble TCVT.THIMA

Fig. #44

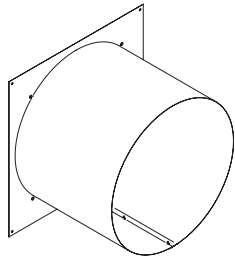

WALL SHIELD / CEILING FIRESTOP
TCVT.THIMA - OPTIONAL

Wall Termination Kit

TCVT.WTA

Fig. #45

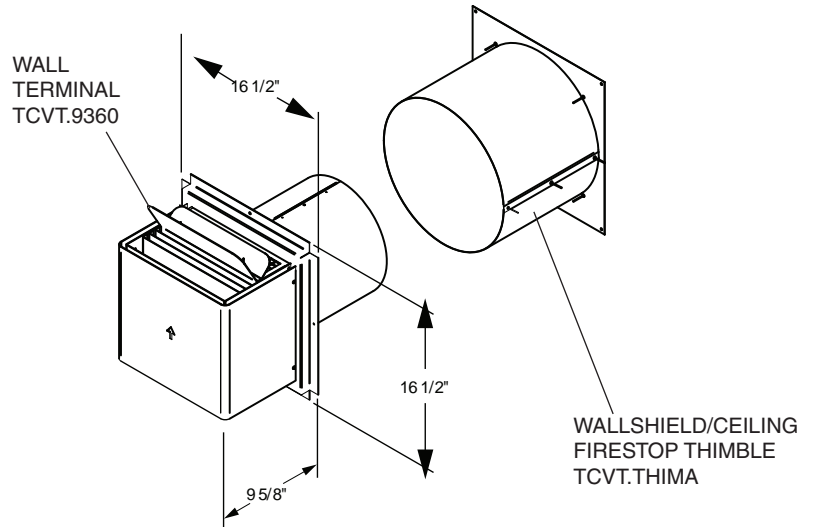

Roof Termination Kit

TCVT.RTA

Fig. #46

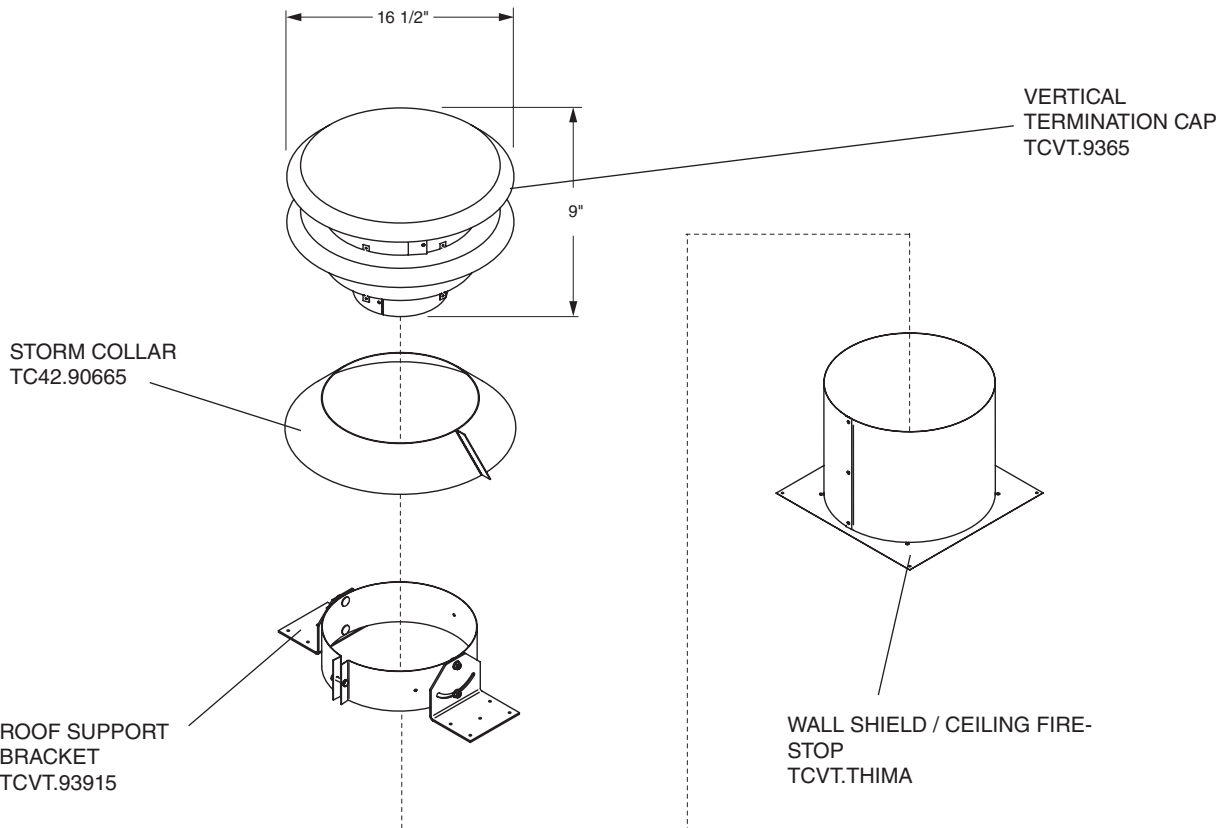

Vent Pipe Dimensions

Fig. #47

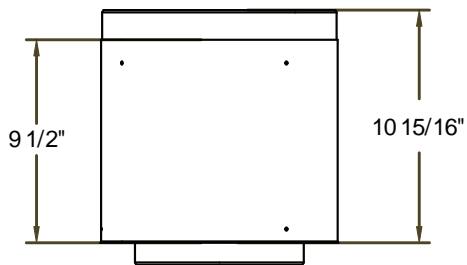

TCVT.811X12ADJ

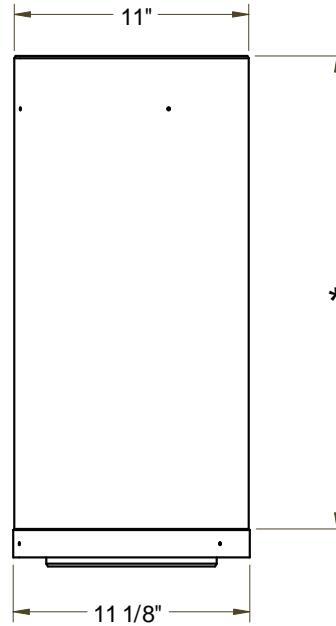

TCVT.811X__

12" PIPE	10 1/4"
18" PIPE	16 1/4"
24" PIPE	22 1/4"
48" PIPE	46 1/4"

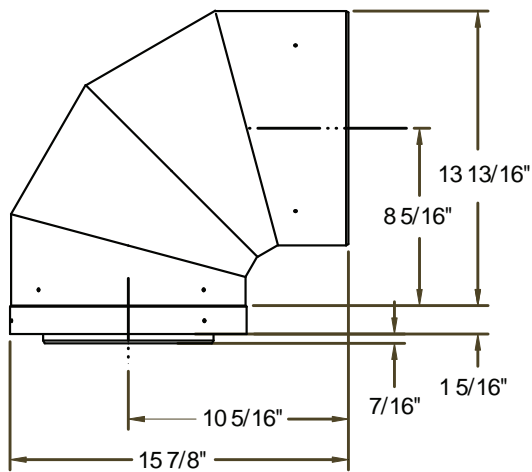

TCVT.811XLB90

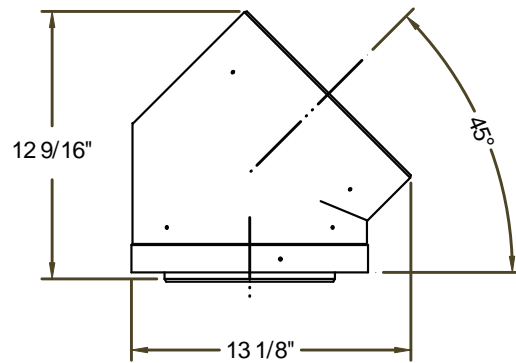

TCVT.811XLB45

Vent Offset Chart

Fig. #48

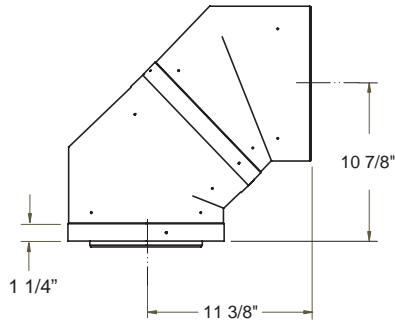

A	B	C
12" PIPE	18 5/8"	18"
18" PIPE	22 7/8"	22 3/8"
24" PIPE	27 1/8"	26 1/2"
48" PIPE	44 1/16"	43 1/2"

ADDING AN ADJUSTABLE SECTION TO PIPE WILL INCREASE OFFSET BY 2 1/8" TO 6 3/4"

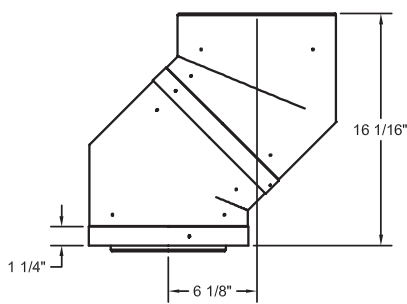
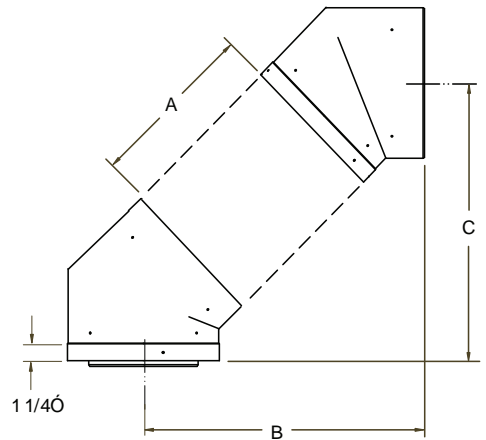

A	B	C
12" PIPE	13 7/16"	23 1/4"
18" PIPE	17 9/16"	27 5/8"
24" PIPE	21 7/8"	31 3/4"
48" PIPE	38 3/4"	44 7/8"

ADDING AN ADJUSTABLE SECTION TO PIPE WILL INCREASE OFFSET BY 2 1/8" TO 6 3/4"

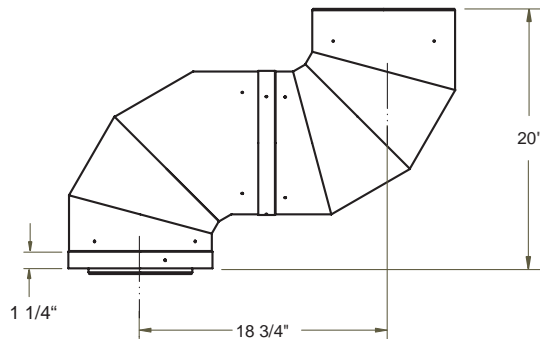
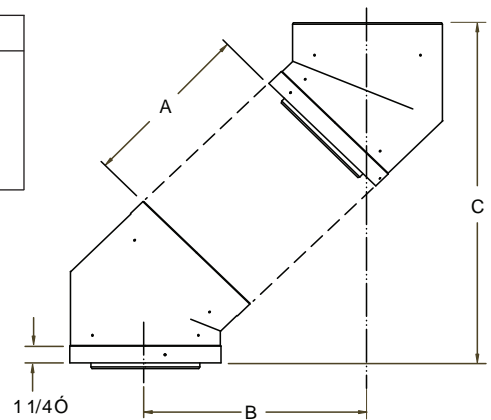

A	B
12" PIPE	29"
18" PIPE	35"
24" PIPE	41"
48" PIPE	65"

ADDING AN ADJUSTABLE SECTION TO PIPE WILL INCREASE OFFSET BY 3" TO 9 1/2"

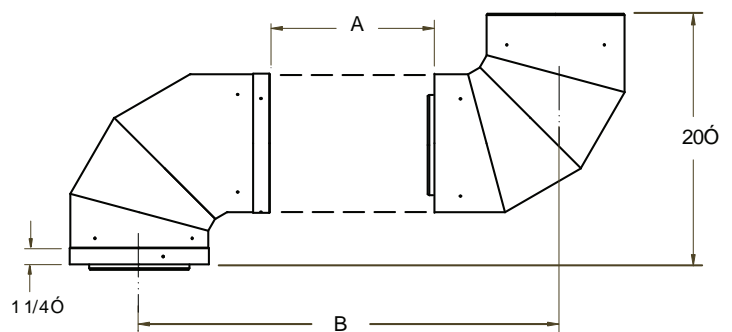

Firebox Panels Installation

TC30 PANELS

PARK AVE. HERRINGBONE 2	TCPN.30PAC2
MANHATTAN STACKED BRICK 2	TCPN.30MCN2
MT. VERNON RED BRICK 2.....	TCPN.30VRC2
BLACK PORCELAIN	TCPN.770.C
COFFE BEAN BROWN PORCELAIN	TCPN.770CB.C
MILAN 2	TCPN.30MILC2
TITANIUM.....	TCPN.770TI.C
COPPER	TCPN.770CU.C

See Porcelain panel instruction manual for specific instructions for these panels before proceeding see burner instructions.



UPPER FIREBOX SHIELD
SIDE PANEL RETAINER

A Firebox Panel Set must be installed for safe operation. Do not use the fireplace without panels. Unpack and inspect all panels. The panels need to be installed before the logs and grate are in place.

Caution: The Firebox Panels are very fragile, and should be handled with care.

1. Remove the Side Panel Retainers located on the underside of the firebox heat shield. The retainers are each held in place by one screw.
2. Install the Rear Lower Panel.
3. Install the Right Side Panel by inserting the bottom of the panel in first and then angling it up into position. It may be necessary to push the firebox shield up to allow panel to move freely into place.
4. Install the Rear Upper Panel.
5. Install the Left Side Panel by inserting the bottom of the panel in first and then angling it up into position.
6. Re-install the Side Panel Retainers.
7. Install the Left and Right Front Panels.

(HERITAGE RED BRICK PANEL SET SHOWN)

- LEFT SIDE PANEL
- REAR UPPER PANEL
- RIGHT SIDE PANEL
- REAR LOWER PANEL
- LEFT FRONT PANEL
- RIGHT FRONT PANEL



Finishing Touch Trim Kit Instructions

1. Place two smaller magnets on back of each side rail.
2. Place two larger magnets on back of the top and bottom rails.
3. Attach the side rails. Even the ends up with the door frame.
4. Attach the top and bottom rails and adjust so mitres are even at the corners.
5. Place TC magnetic logo in bottom right corner.

Fig. #51

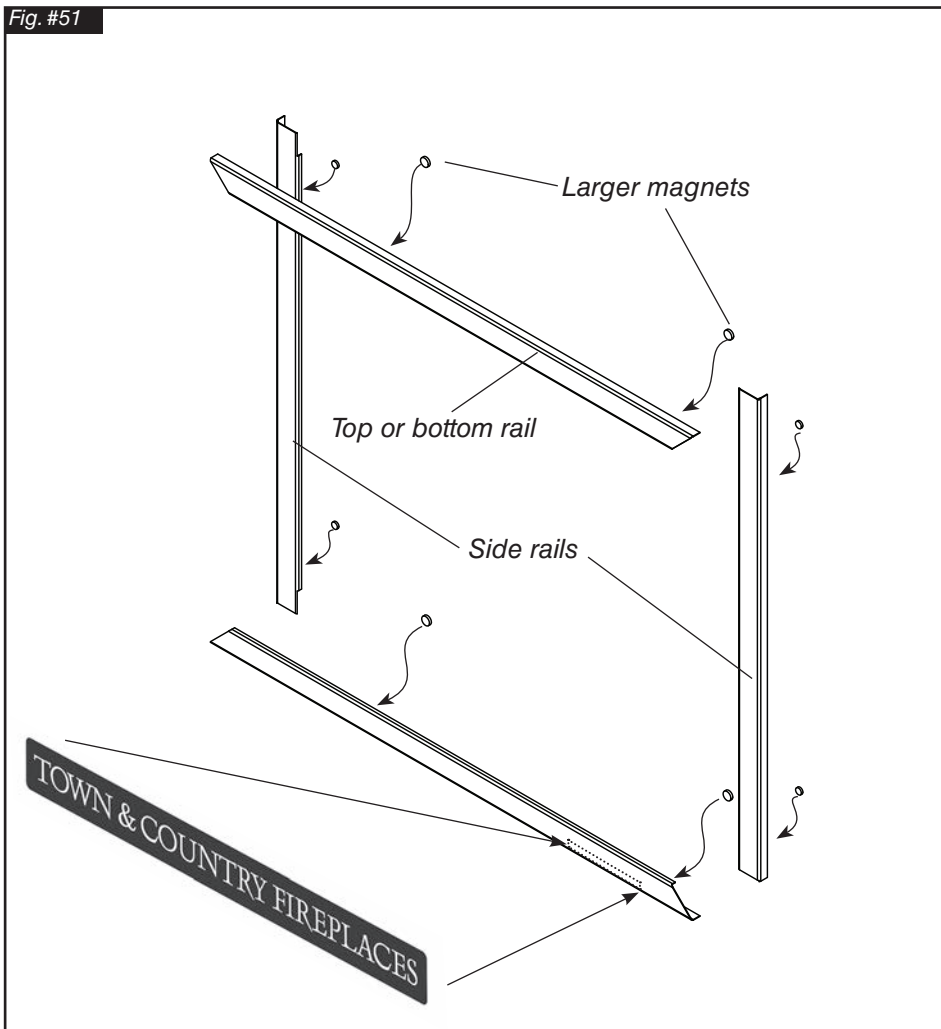

Lighting Instructions

FOR YOUR SAFETY READ BEFORE LIGHTING

WARNING: If you do not follow these instructions exactly, a fire or explosion may result causing property damage, personal injury or loss of life.

- A. This appliance is equipped with an ignition device which automatically lights the pilot. Do not try to light the pilot by hand.
- B. BEFORE LIGHTING smell all around the appliance area for gas. Be sure to smell next to the floor because some gas is heavier than air and will settle on the floor.
- WHAT TO DO IF YOU SMELL GAS:**
- Do not try to light any appliance.
 - Do not touch any electric switch; do not use any phone in your building.

- Immediately call your gas supplier from a neighbour's phone. Follow the gas supplier's instructions.
 - If you cannot reach your gas supplier, call the fire department.
- C. Use only your hand to push in or turn the gas control knob. Never use tools. If the knob will not push in or turn by hand, don't try to repair it, call a qualified service technician. Force or attempted repair may result in a fire or explosion.
- D. Do not use this appliance if any part has been under water. Immediately call a qualified service technician to inspect the appliance & to replace any part of the control system & any gas control which has been under water.

LIGHTING INSTRUCTIONS

1. STOP! Read the safety information above on this label.
2. This appliance is equipped with an ignition device which automatically lights the pilot. Do not try to light the pilot by hand.
3. Push the "On/ Off" switch to turn the fireplace ON.
 - If the burner does light go to step 6.
 - If the burner does not light, complete steps 4 through 5.
 - If the burner will not light or stay lit after several tries, push the "On/ Off" switch for the fireplace to OFF, turn off all electric power

- to the fireplace and call your service technician or gas supplier.
- Note: Sufficient time must be allowed for air to escape from lines if the unit is being lit for the first time.
4. Push the "On/ Off" switch to the fireplace Off.
 5. Allow sufficient length of time (minimum 5 minutes) for any gas in the combustion chamber to escape. If you still smell gas, STOP! Follow "B" in the safety information above on this label. If you don't smell gas, go to step 3.
 6. Set fireplace to desired setting by using hand held remote.

TO TURN OFF GAS APPLIANCE

1. Push the "on/ off" switch to the "Off" position.
2. Turn off all electric power to the appliance and remove backup batteries if service is to be performed or for extended shutdown.

Due to high surface temperatures, keep children, clothing and furniture away. Keep burner and control compartment clean. See installation and operating instructions accompanying the appliance.
A cause de la temperature elevee des parois, tenir eloignes les enfants, les vetements et les meubles. Maintenir propres le bruleur et le compartiment de commande. Voir les instructions relatives a l'installation et au fonctionnement qui accompagnent l'appareil.

CAUTION: Hot while in operation. Do not touch. Severe burns may result. Keep children, clothing, furniture, gasoline and other liquids having flammable vapours away. Keep burner and control compartment clean. See installation and operating instructions accompanying the appliance.

ATTENTION: L'appareil est chaud lorsqu'il fonctionne. Ne pas toucher l'appareil. Risque de brûlures graves. Surveiller les enfants. Garder les vêtements, le meubles, l'essence ou autres liquides produisant des vapeurs inflammables loin de l'appareil. S'assurer que le brûleur et le compartiment des commandes sont propres. Voir les instructions d'installation et d'utilisation qui accompagnent l'appareil.

090713

5051.185

GBWY

First Fire

When lit for the first time, the fireplace will emit a slight odor for a couple of hours. This is due to the curing of paints, sealants and lubricants used in the manufacturing process. This condition is temporary. Open doors and windows to ventilate area. Odors caused by the curing process may cause discomfort to some individuals.

It is normal for fireplaces fabricated of steel to give off some expansion and/or contraction noises during the start up or cool down cycle. Similar noises are found with your furnace heat exchanger or cook stove oven.

Special Operator Note

NOTE: Fireplace may take up to 30 seconds to ignite each time the “ON” button has been selected.

Remote Control Operation



Fig. #52 Remote Control Transmitter

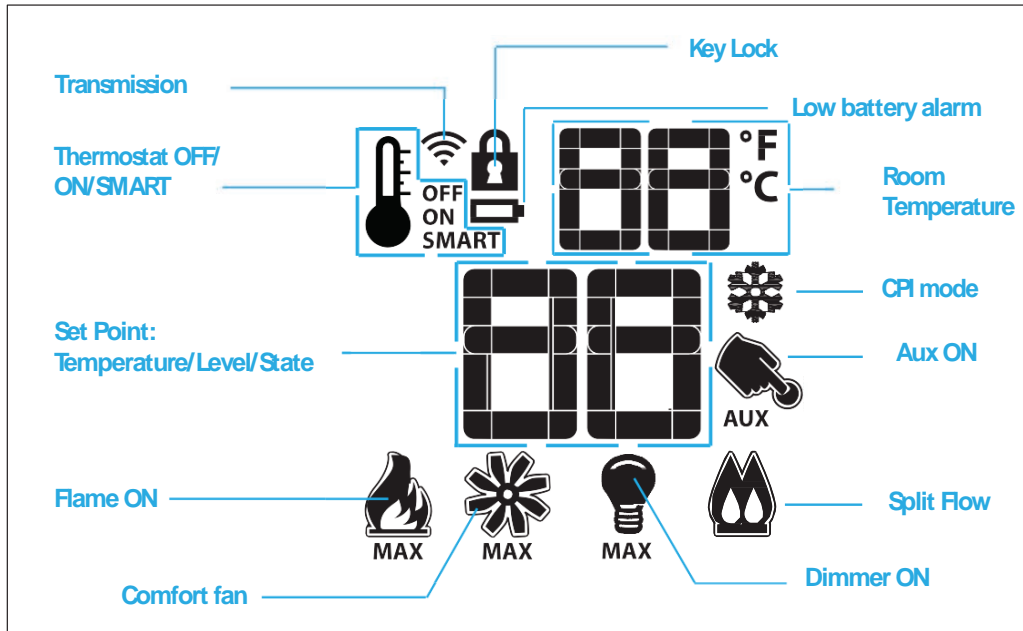

Fig. #53 Remote Control Transmitter LCD display.
 Note: Some functions may not be available

Attention!

- Turn off the main gas supply for the appliance during installation or maintenance of the receiver/module device.
- Turn off main gas supply for the appliance prior to removing or reinserting the batteries.
- In case of remote control malfunction, turn off the fireplace using the “on/off” main switch located on the wall.
- For installation/maintenance, turn off the fireplace at the on/off switch located on the wall and at the fireplace power supply circuit breaker.

Fireplace Description

The Proflame2 Remote Control Fireplace consists of three elements:

1. Proflame2 Remote Control Transmitter.
2. Proflame Integrated Fireplace Control (IFC Module) board and a wiring harness to connect the IFC to the gas valve and stepper motor (Fig. 23, page 14).
3. Wall mounted Remote Control Receiver (Figs. 54 - 56).

Transmitter (Remote Control with LCD Display)

The Proflame2 Transmitter uses a streamline design with a simple key layout and an informative LCD display (Fig. 53). The remote control transmitter is powered by 3 AAA batteries. A mode key is provided to index between the features and a thermostat key is used to turn on/off or index through thermostat functions (Fig. 52)

IFC Module

The Proflame2 Integrated Fireplace Control (IFC) module is a device that allows automatic ignition and pilot flame supervision and commands the functions of the fireplace. It's configured to control the ON/OFF main burner operation, giving the choice of both IPI (intermittent pilot ignition), and CPI (continuous pilot ignition) modes. The Proflame2 IFC module controls and connects directly to the pilot assembly and the automatic valve using low electric power.

The IFC module can be powered by both an AC power supply, and battery pack for back up. The Proflame2 offers the added ability to control the comfort fan speed from OFF through six (6) speeds, and a remotely actuated auxiliary outlet and a dimmable light outlet. The external batteries can provide DC power to the IFC allowing the batteries to be used only when line power is interrupted or lost, and if the fireplace does not use a combustion fan.

Operating Procedure

Initializing the Fireplace for the first time

1. With the fireplace main circuit breaker in the OFF position, Install 4 AA batteries into the Town & Country wall switch battery holder (Fig. 55) located behind the wall switch face plate (Fig. 55). Make sure that the selection switch is on the "Remote" setting.
2. Install 3 AAA batteries into the Proflame2 Remote Control Transmitter (Fig. 57).
3. Turn ON the fireplace main circuit breaker and open the gas supply line (if valve is present and accessible).
4. Insert a straightened paper clip into the opening marked "Program" of the Town & Country wall switch (Fig. 56) and press the program key once. The IFC module, also located on the inside of the fireplace enclosure, will beep 3 times indicating that it is ready to synchronize with a remote control transmitter.
5. On the remote control transmitter, push the power on key once. The remote control transmitter will beep 4 times to indicate that the remote control transmitter and the IFC module are now synchronized. The remote control transmitter is now ready to use.

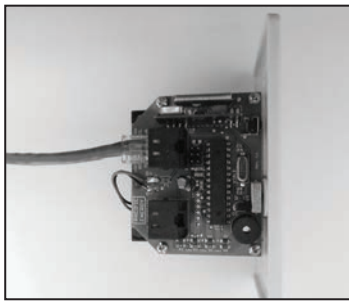

Fig. #54 wall switch electronics

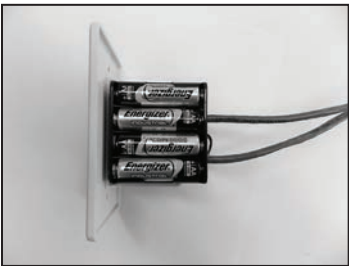

Fig. #55 wall switch batteries side



Fig. #56 Town & Country wall switch face plate.



Fig. #57 Remote Control Transmitter battery bay

Using the Remote Control Transmitter

Temperature indication Display

With the remote control transmitter in the "OFF" position, press the thermostat and mode keys at the same time. Look at the LCD screen on the remote control transmitter to verify that a C or F is visible to the right of the room temperature display. (Fig. 58 & Fig. 59)

Turn on the Fireplace

With the fireplace OFF, press the ON/OFF key on the remote control transmitter. The remote control transmitter display will show the active icons on the screen. At the same time the wall switch will activate the fireplace via the IFC module. A single "beep" from the IFC module will confirm reception of the command.

Turn off the Fireplace

With the fireplace ON, press the ON/OFF key on the remote control transmitter. The remote control transmitter LCD display will only show the room temperature (Figs. 58 or 59). At the same time the IFC module will turn off the fireplace. A single "beep" from the IFC module confirms reception of the command.

Manual Bypass of the Remote Fireplace

If the batteries of the remote control transmitter are low or depleted, the fireplace can be turned off manually using ON/OFF switch located on Town & Country wall switch. This will bypass the remote control transmitter.

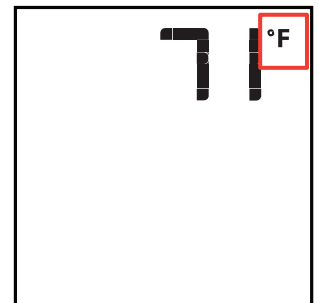

Fig. #58 Display in Fahrenheit

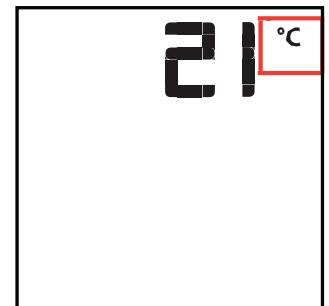

Fig. #59 Display in Celcius

Remote Flame Control

The Proflame2 has six (6) flame levels. With the fireplace turned on, and the flame level at maximum height, press the down arrow key once (Fig. 60 Flame level 1) to reduce the flame height by one step until the flame is turned off.

The up arrow key will increase the flame height each time it is pressed. If the up arrow key is pressed while the fireplace is on but the flame is off, the flame will come on in the high position. (Fig. 60 - Flame level Max) A single “beep” will confirm reception of the command.

ROOM THERMOSTAT (Transmitter Operation)

The remote control transmitter can operate as a room thermostat. The thermostat can be set to a desired temperature to control the comfort level in a room. To activate this function, press the thermostat key (Fig. 52). The LCD display on the remote control transmitter will change to show that the room thermostat is “ON” and the set temperature is now displayed (Fig. 61). To adjust the set point, press the up or down arrow keys until the desired set point temperature is displayed on the LCD screen of the remote control transmitter.

Smart Thermostat (Transmitter Operation)

The Smart Thermostat function adjusts the flame height in accordance to the difference between the set point and the room temperatures. As the room temperature gets closer to the set point, the Smart Function will modulate the flame down. If the room temperature is cool, the Smart Function will modulate the flame up. To activate this function, press the THERMOSTAT button (Fig. 52) until the word “SMART” appears to the right of the temperature icon (Fig. 62). To adjust the set point, press the up or down arrow buttons until the desired set point temperature is displayed on the LCD screen of the remote control transmitter (Fig. 62 & 63).

Comfort Fan Speed Control

If the Heater is equipped with a hot air circulating fan, the speed of the fan can be controlled by the Proflame2 System. The fan speed can be adjusted through six (6) speeds. To activate this function use the Mode Key (Fig. 52) to index to the fan control icon (Fig. 64). Use the Up/Down Arrow Keys (Fig. 52) to turn on, off or adjust the fan speed (Fig. 65). A single “beep” will confirm reception of the command.

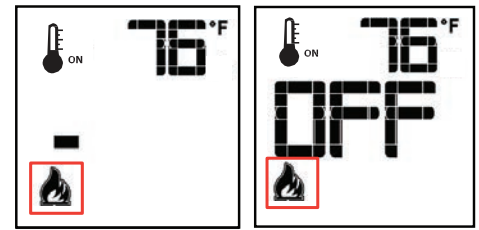

Flame level 1

Flame Off

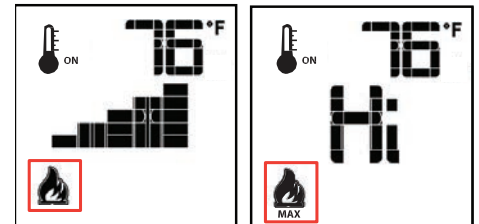

Flame level 5

Flame level Max

Fig. 60 Flame level control

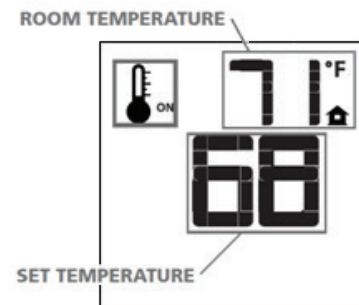

Fig. 61 Flame level control

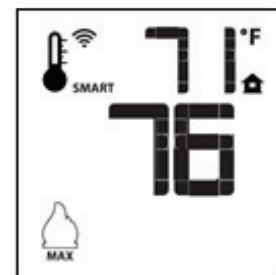

Fig. 62 Smart Flame function

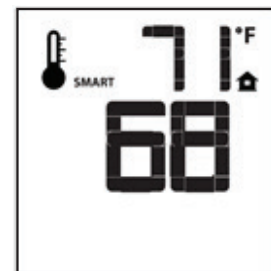

Fig. 63 Smart Flame function



Fig. 64
Comfort fan
speed “OFF”

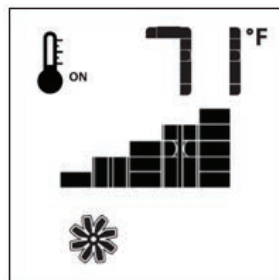

Fig. 65
Comfort fan
speed “MAX”

Remote dimmer control (Light)

The auxiliary function controls the AUX power outlet by the dimmable light control. To activate this function use the Mode Key (fig. 52) to index to the light bulb icon (fig. 66). The intensity of the output can be adjusted through six (6) levels. Use the Up/Down Arrow Keys (Fig.52) adjust the output level (fig. 66). A single “beep” will confirm reception of the command.

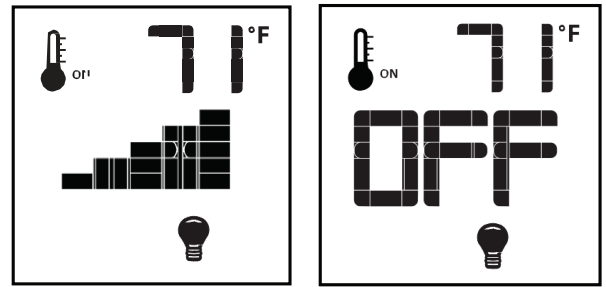

Fig. 66 Dimmer light control

Continuous Pilot/Intermittent Pilot (CPI/IPI) selection

With the system in the “OFF” position, press the Mode Key (Fig. 52) to index to the CPI mode icon (Fig. 67). Pressing the Up Arrow Key will activate the Continuous Pilot Ignition mode (CPI). Pressing the Down Arrow Key will return to IPI. A single “beep” will confirm the reception of the command.

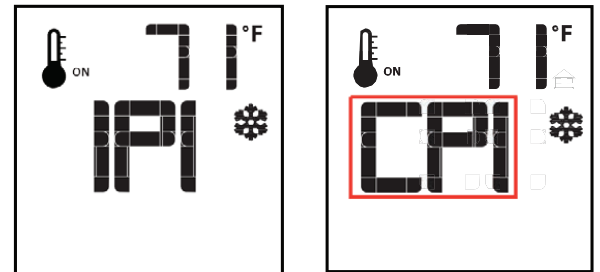

Fig. 67 IPI/CPI control

Key Lock

This function will lock the keys to avoid unsupervised operation. To activate this function, press the MODE and UP keys at the same time.(Fig. 52) The lock icon will appear (Fig. 68). To de-activate this function, press the MODE and UP key at the same time.

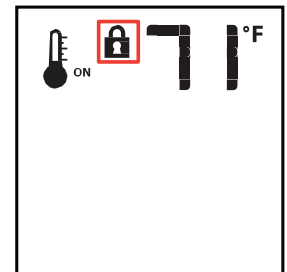

Fig. 68 Key Lock

Low Battery Power Detection

Transmitter

The life span of the remote control batteries depends on various factors: quality of the batteries used, the number of ignitions of the Heater, the number of changes to the room thermostat set point, etc.

When the remote batteries are low, an icon will appear on the LCD display of the remote (Fig. 69) before all battery power is lost. When the batteries are replaced this icon will disappear.

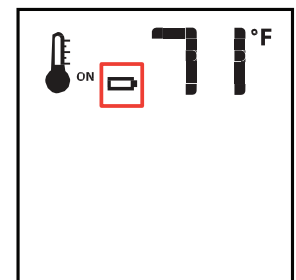

Fig. 69 Low battery icon

Receiver

The life span of the IFC module batteries depends on various factors: quality of the batteries used, the number of ignitions of the Heater, the number of changes to the room thermostat set point, etc.

When the IFC batteries are low, a “double-beep” will be emitted from the IFC module when it receives a command from the remote. This is an alert for a low battery condition for the IFC board. When the batteries are replaced, a single “beep” will be emitted from the IFC module when a key is pressed (See Initialization of The System on page 36).

APPENDIX

Maintenance

CAUTION:

Turn off gas and electrical power supply (if applicable) and allow ample time for unit to cool before servicing appliance. It is recommended that the fireplace and its venting should be inspected at least once a year by a qualified service person.

Glass Panel:

Warning: Do not operate fireplace with glass panel removed, cracked or broken. Replacement of the glass panel should be done by a licensed or qualified service person.

Do not strike or otherwise impact the glass in anyway that may cause it to break. If the glass becomes cracked or broken it must be replaced before using the fireplace. Replacement glass can be obtained from your nearest Town & Country Fireplaces™ dealer. The size required is 30" x 26" x 5mm. Use ceramic glass only. **Do not substitute with any other type.**

To remove broken glass, remove window frame as noted in "Window Frame Removal" section.

Unclip the Glass Retainer Clips located at the top and sides of the Window Frame. Pull the top edge of the glass out of the frame first, then lift it up and out of the bottom edge.

Install the new piece of glass with the gasket into the frame so that the thicker bead of gasket faces the fireplace.

Re-install glass retaining clips.

Annual Inspection:

- a) Remove glass panel and inspect the decorative burner media (such as logs, pebbles, glass etc) for soot build up. If excessive build up of soot is present, have a qualified service person inspect and adjust the unit for proper combustion. Clean the decorative media and use a brush or vacuum cleaner to clean the burner, paying close attention to the burner ports.
- b) Check the pilot system for proper flame size and operation. Clean pilot free of soot, dust or any other deposits. (See Fig. #70)
- c) Check that the vent pipe and vent terminal are open and free from blockage or debris. If the venting is disassembled for cleaning, it must be properly assembled and re-sealed. Refer to VENTING section for proper procedure.
- d) Check glass panel gasket, replace if necessary. It is important that the glass seal be maintained in good condition.
- e) Check and replace batteries as needed.

Note: The appliance area must be kept clear and free from combustible materials, gasoline and other flammable vapours and liquids.

Periodically:

- a) Viewing glass may be cleaned as necessary with fireplace glass cleaner.
- b) Exterior finish may be cleaned with mild soap and water.

CAUTION:

Do not use abrasive cleaners on glass or any other part of the fireplace.

Do not clean glass when hot.

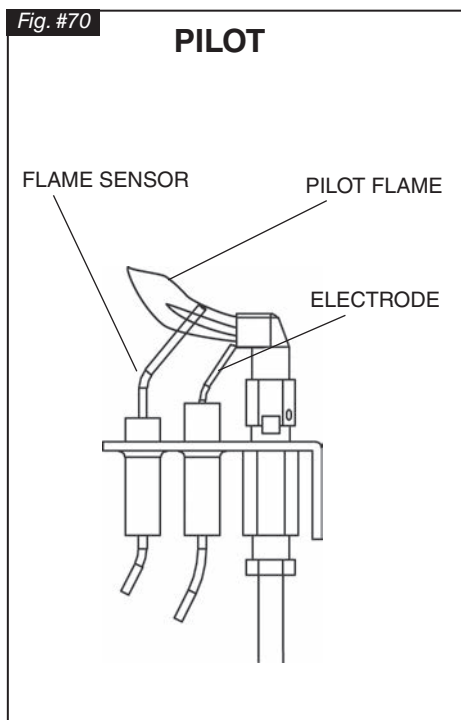

TC30_D Replacement Parts

(WHEN ORDERING, INCLUDE PART NUMBER WITH DESCRIPTION)

ITEM	DESCRIPTION	PART NO.
#1	TC30 BODY.....	TC30.D
#2	GLASS ASSM C/W GASKET	GLAS.2066
#3	FRAMING KIT	TC30. BFRKITA

ITEM	DESCRIPTION	PART NO.
#4	PANEL SETS	
	PARK AVE. HERRINGBONE 2.....	TCPN.30PAC2
	MANHATTAN STACKED BRICK 2.....	TCPN.30MCN2
	MT. VERNON RED BRICK 2.....	TCPN.30VRC2
	BLACK PORCELAIN	TCPN.770.C
	COFFE BEAN BROWN PORCELAIN	TCPN.770CB.C
	MILAN 2	TCPN.30MILC2
	TITANIUM.....	TCPN.770TI.C
	COPPER.....	TCPN.770CU.C

Fig. #71

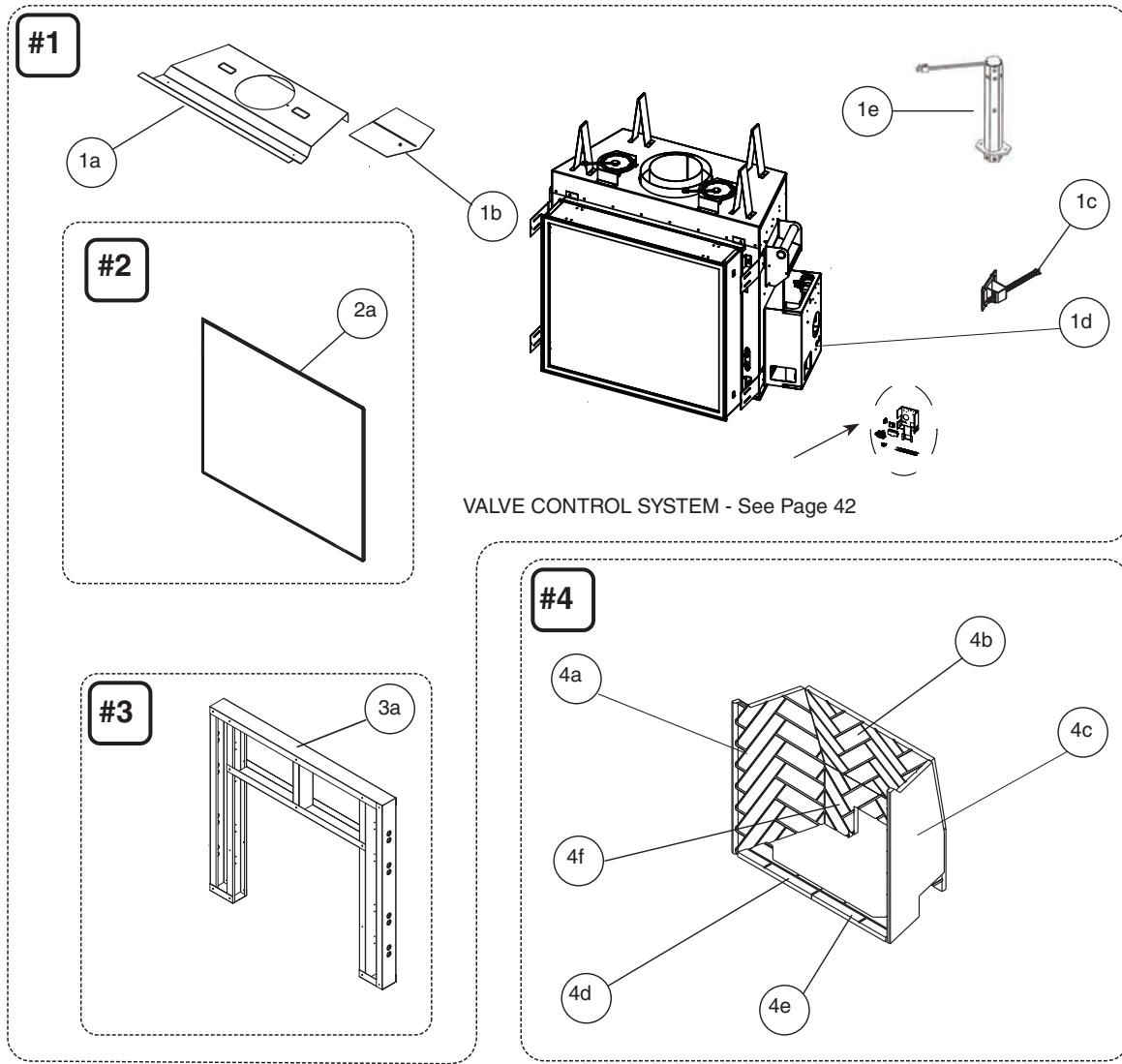

VALVE CONTROL SYSTEM - See Page 42

KIT CONTENTS:

- #1.....TC30 BODY ASSEMBLY
- 1a FIREBOX SHIELD (c/w insulation)
- 1b FLUE DAMPER
- 1c SPRING LATCH ASSEMBLY(2)
- 1d CONTROL ASSEMBLY HOLDER
- 1e LED LIGHT ASSEMBLY
- BRICK PANEL RETAINER (not shown)

- #2.....GLASS ASSEMBLY
- 2a REPLACEMENT GLASS (c/w gasket)

- #3.....FRAMING KIT
- 3a STEEL STUDS

- #4.....PANEL SETS
- 4a PANEL, LEFT SIDE
- 4b PANEL, UPPER
- 4c PANEL, RIGHT SIDE
- 4d PANEL, LEFT BASE
- 4e PANEL, RIGHT BASE
- 4f PANEL, LOWER BACK

Replacement Parts – Valve Control System

(WHEN ORDERING, INCLUDE PART NUMBER WITH DESCRIPTION)

ITEM	DESCRIPTION	PART NO.	ITEM	DESCRIPTION	PART NO.
#1	CONTROL ASSEMBLY KIT	TCCV.95755-B	#4	REMOTE TRANSMITTER.....	5003.07-B
#2	BULKHEAD ASSEMBLY KIT	TCVV.9285	#3	TEST FITTING	5019.104

Fig. #72

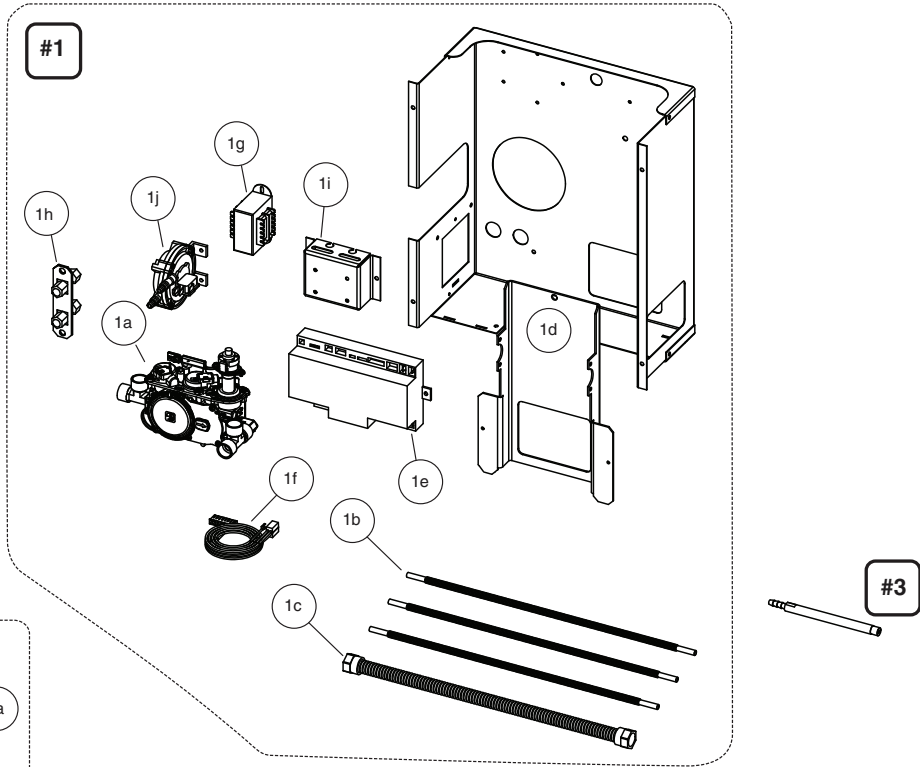

KIT CONTENTS:

- #1.... CONTROL ASSEMBLY KIT**
- 1a VALVE c/w FITTINGS
 - 1b 1/4" FLEX TUBE
 - 1c 1/2" FLEX TUBE
 - 1d CONTROL MOUNTING BRACKET
 - 1e IGNITION MODULE
 - 1f WIRING HARNESS
 - 1g TRANSFORMER
 - 1h PRESSURE TEST ASSEMBLY
 - 1i REGULATOR BOARD
 - 1j PRESSURE SWITCH

- #2.... BULKHEAD ASSEMBLY KIT**
- 2a INLET PLATE
 - 2b INLET PLATE GASKET
 - 2c ELEC BULKHEAD GASKET
 - 2d 1/2" BULKHEAD FITTING
 - 2e 1/4" BULKHEAD FITTING
 - 2f ELEC BULKHEAD FITTING

#3.... TEST FITTING

#4.... REMOTE TRANSMITTER
(not shown)

Wiring Diagram

Fig. #73

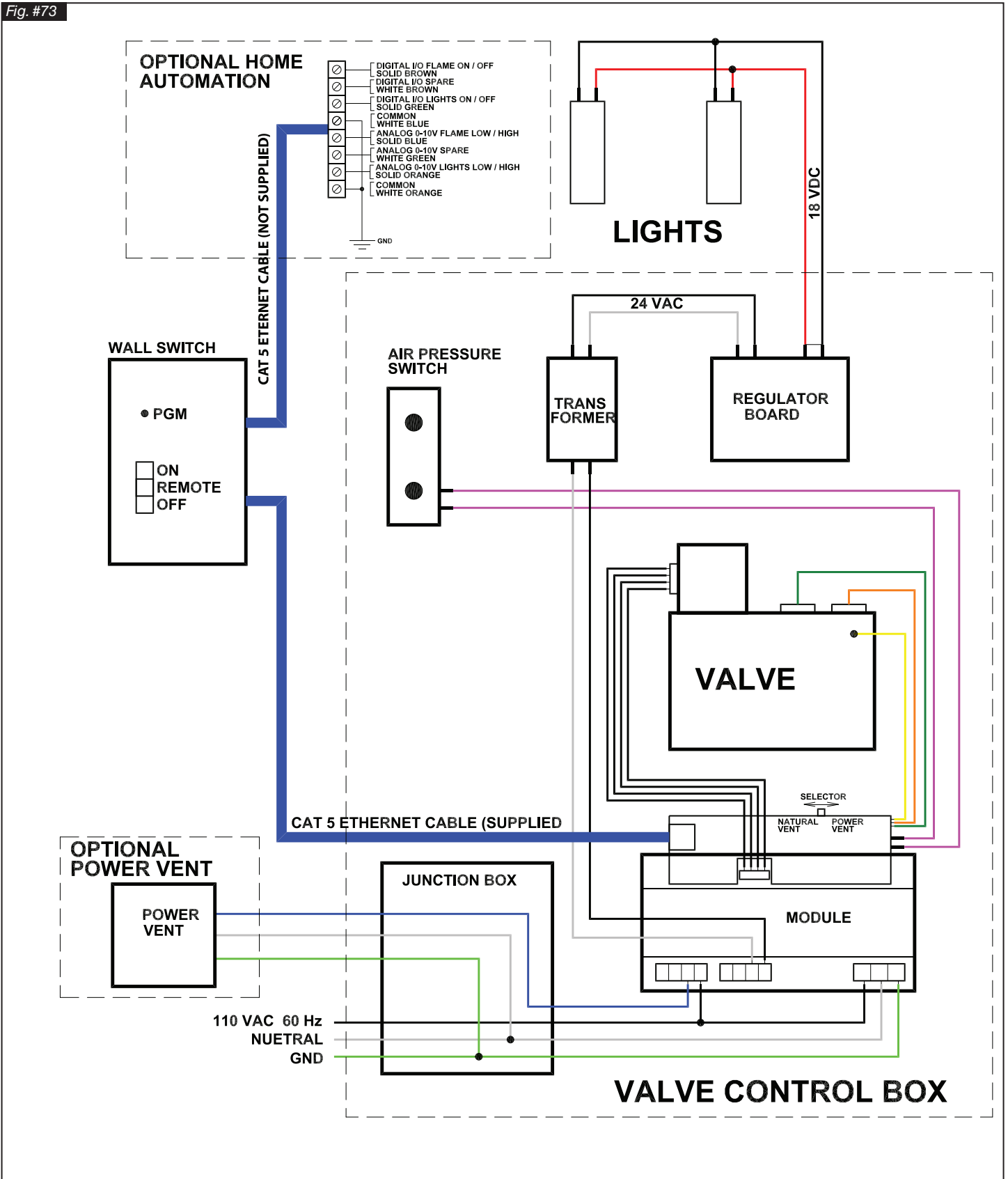

Rating Label

NOTE: The Rating Label is located on a plate found in a slot between the left hand side lintel and the left hand side window frame. This plate is attached to the lintel with a cable.



**VENTED GAS FIREPLACE - NOT FOR USE WITH SOLID FUEL
FOYER AU GAZ À ÉVACUATION - NE PAS UTILISER AVEC DU
COMBUSTIBLE SOLIDE**

711

ANSI Z21.50-2014 / CSA 2.22-2014 Vented Gas Fireplaces
CAN/CGA 2.17-M91 Gas-Fired Appliance For Use At High Altitudes.
Certified for / Certifié pour Canada and U.S.A.

This Appliance is Equipped For Use With /
Cet Appareil est Équipé Pour Utiliser Avec :

NATURAL GAS ■ LP-GAS ■
GAZ NATUREL ■ LP GAZ ■

TOWN & COUNTRY
FIREPLACES™

MODEL/
MODELE: ■ TC30

SERIES/
SERIE: D

MADE IN CANADA
FABRIQUE AU CANADA

FOR USE WITH/ EN CASE D'EMPLOI AVEC:	NATURAL GAS/ DU GAZ NATUREL	LP GAS/ DU GAZ LP
Minimum supply pressure / Pression minimum d'alimentation: (For the purpose of input adjustment / dans le but de régler l'alimentation) Maximum supply pressure / Pression maximum d'alimentation:	5.0 in/wc / 5.0 po/c.e. (1.25 kPa) 13.9 in/wc / 13.9 po/c.e. (3.45 kPa)	12.5 in/wc / 12.5 po/c.e. (3.11 kPa) 13.9 in/wc / 13.9 po/c.e. (3.45 kPa)
Manifold pressure / Pression de la tuyauterie: Maximum	3.5 in/wc / 3.5 po/c.e. (0.95 kPa)	10.0 in/wc / 10.0 po/c.e. (2.74 kPa)
Orifice Size / Diametre de l'injecteur:	(2.95 mm)	(1.9 mm)
Input BTU/hr (kW) / Entree BTU/h (kW):	Max.: 35,000 (10.3) Min.: 24,000 (07.0)	Max.: 35,000 (10.3) Min.: 28,000 (08.2)

Optional components/ Éléments facultatifs: Powervent Kit/ kit de ventilation mécanique TCVT.PVI.25, TCVT.PV7.110, TCVT.PVCV
Blower electrical rating: 115v, 60hz, 1.1 A / Normes électriques du ventilateur: 115v, 60hz, 1.1 A
This appliance equipped for altitudes 0 - 4500 ft. (0 - 1372 m) / Cet unité est conçu pour des altitudes variant entre 0 - 4500 pieds (0 - 1372 m). In Canada, also certified for installation in a bedroom or a bedsitting room / Aussi certifié pour installation dans une chambre à coucher ou une salle de séjour. This appliance must be installed in accordance with local codes, if any; if none, follow the current CAN/CGA-B149 (Canada), or ANSI Z223.1 (USA) Installation Codes. Installer l'appareil selon les codes ou règlements locaux, ou, en l'absence de tels règlements, selon les codes d'installation CAN/CGA-B149 (Canada), or ANSI Z223.1 (USA) en vigueur.

MANUFACTURED (MOBILE) HOME: This appliance is only for use with the type of gas indicated on the rating plate and may be installed in an aftermarket, permanently located, manufactured (mobile) home where not prohibited by local codes. See owners manual for details.
FABRIQUEZ (MOBILE) MAISON: Cet appareil doit être utilisé uniquement avec le type de gaz indiqué sur la plaque signalétique et peut être installé dans une maison préfabriquée (mobile) installée à demeure si les règlements locaux le permettent. Voir la notice du propriétaire pour plus de détails. Cet appareil ne peut être converti à d'autres gaz sauf si une trousse de conversion certifiée est utilisée.
Install in accordance with the current standard Mobile Homes, CAN/CSA Z240 MH (in CANADA), and the Manufacturer's Home Construction and Safety Standard, Title 24 CFR, Part 3280, or the current Standard for Fire Safety Criteria for Manufactured Home Installations, Sites, and Communities ANSI/NFPA 501A, (in the U.S.A.). Cet appareil doit être installé conformément aux exigences de la norme CAN/CSA Z240 MH en vigueur de l'ACNOR, Installations de gaz dans les Constructions Mobiles.

FOR USE WITH THE GLASS AND SCREEN BARRIER CERTIFIED WITH THE APPLIANCE ONLY / POUR UTILISATION UNIQUEMENT AVEC LES PORTES IN VERRE CERTIFIÉES AVEC L'APPAREIL

MINIMUM CLEARANCES TO COMBUSTIBLES / CLAIRANCES MINIMALES AVEC LES COMBUSTIBLE
Left and Right side are determined when facing the front of the appliance. / Les côtés droit et gauche se déterminent en se mettant devant l'appareil et en lui faisant face.

Top, Back and Side Standoffs / Sommet, Arrière et Côté Butée	0 in./ 0 po.	(0 mm)
Sidewall to Appliance / Du mur latéral a l'appareil	4 in./ 4 po.	(102 mm)
Ceiling to Appliance / Plafond a l'appareil	24 in./ 24 po.	(610 mm)
Mantel to Appliance / Du manteau a l'appareil	*9 in./ 9 po.	(229 mm)
Maximum Mantel Extension / Allongement maximum du manteau *See Installation Manual for more detail / Voyez des Directive de l'Installation pour plus détails.	*12 in./ 12 po.	(305 mm)
Mantel Supports / Supports du manteau	4 in./ 4 po.	(102 mm)
Vent Pipe / Déchargez le Tuyau	1.75 in./ 1.75 po.	(45 mm)

Pacific Energy
Fireplace Products Ltd.
Duncan, British Columbia,
Canada

DATE OF MANUFACTURE

JAN	FEB	MAR	APR	2014
MAY	JUN	JUL	AUG	2015
SEP	OCT	NOV	DEC	2016

WARNING: Improper installation, adjustment, alteration, service or maintenance can cause injury or property damage. Refer to the owner's information manual provided with this appliance. For assistance or additional information, consult a qualified installer, service agency or the gas supplier.

AVERTISSEMENT: Une installation, un réglage, une modification, une réparation ou un entretien mal effectué peut causer des dommages matériels ou des blessures. Voir la notice de l'utilisateur qui accompagne l'appareil. Pour de l'aide ou des renseignements supplémentaires, consultez un installateur, un technicien agréé ou le fournisseur de gaz.

200814

5056.429D

1-TC30-D

Reproduction, adaptation, or translation
without prior written permission is prohibited,
except as allowed under the copyright laws.



TOWN & COUNTRY
L U X U R Y F I R E P L A C E S

For technical support, please contact your retailer.

**Web site: www.townandcountryfireplaces.net
2975 Allenby Rd., Duncan, BC V9L 6V8**